



HAL
open science

Reduction of the impulsive noise emitted by a resistive load commutation

V. Guillet, Guy Lamarque, Philippe Ravier, Christophe Léger

► **To cite this version:**

V. Guillet, Guy Lamarque, Philippe Ravier, Christophe Léger. Reduction of the impulsive noise emitted by a resistive load commutation. ISPLC 2008, Apr 2008, Jeju Island, South Korea. hal-00608067

HAL Id: hal-00608067

<https://hal.science/hal-00608067v1>

Submitted on 12 Jul 2011

HAL is a multi-disciplinary open access archive for the deposit and dissemination of scientific research documents, whether they are published or not. The documents may come from teaching and research institutions in France or abroad, or from public or private research centers.

L'archive ouverte pluridisciplinaire **HAL**, est destinée au dépôt et à la diffusion de documents scientifiques de niveau recherche, publiés ou non, émanant des établissements d'enseignement et de recherche français ou étrangers, des laboratoires publics ou privés.

Reduction of the impulsive noise emitted by a resistive load commutation

Vincent Guillet, Guy Lamarque, Philippe Ravier, Christophe Léger

Laboratory of Electronics Signals and Images

Polytech'Orléans, University of Orléans, FRANCE

E-mail: {vincent.guillet, guy.lamarque, philippe.ravier, christophe.leger}@univ-orleans.fr

Phone: +(33)2.38.49.49.71 or +(33)2.38.41.73.78

Abstract—In power line or any cable communications, impulsive noise is assumed to be the most difficult noise to filter. In particular, it is impossible to predict when a non periodic asynchronous impulsive noise will appear. So, under such noise conditions, the OFDM¹ symbol generally used in PLC², is corrupted. Signal-to-noise ratio is generally improved by detecting and/or filtering such noise to overcome this problem. Unfortunately, this leads to heavy detection and computing time in comparison with the disturbance duration. In this paper, we propose a new approach that consists in controlling the instant of commutation of a load. This approach allows reducing up to 15 dB the asynchronous impulsive noise emitted by a radiator in a 75- μ s typical OFDM symbol duration.

KEYWORDS

Commutation, impulsive noise, Signal-to-Noise Ratio (SNR) improvement.

I. INTRODUCTION

Nowadays, the great majority of systems needs to communicate without extra wire. When the systems are portable, it is quite common to use wireless communication facilities. However, when the systems require the power supply, the communication over power line appears to be a good alternative solution. Actually, this communication channel does not need any additional wire, which is effortless and cheap to set a network in existing buildings. Moreover, it offers Triple Play facilities (Internet, VoIP, Multimedia) thanks to a high PHY³ bit rate, in the range on few hundreds Mbps (Mega bit per second) raw data, and can be achieved through around one hundred meter cable. Thus, achieving such a high bit rate needs allocating the authorized bandwidth in an optimal way. An appropriate modulation like OFDM¹ which has a good spectral efficiency allows taking into account the overall bandwidth. Nevertheless, it is very important to have both a good knowledge of the topology of the communication channel [1] [2], and the associated noises.

Considering the power line communication channel, it is well known that the noise does not agree with the classical Additive White Gaussian Noise (AWGN) model. The model below (Fig. 1), presented in [3], is generally preferred. In this model, the communication channel is mainly disturbed by a set of five noise sources. The background noises [4] (narrow band and colored noises) are frequency localized. Conversely, the impulsive noises [5], [6] are time concentrated.

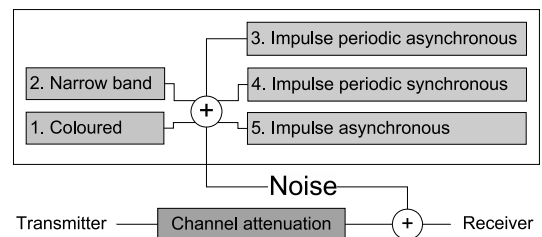

Fig. 1. Power line channel noise description.

Among the impulsive noise class, some are periodic (periodic asynchronous/synchronous impulsive noises) and the others are not (asynchronous impulsive noises).

Among all these types of noise, the asynchronous impulsive one is probably the most difficult noise to deal with. Numerous methods allow to detect and/or filter such noises [5] [7] [8]. However, these methods are computing time consuming and not adapted for real time implementations [9] [10].

As far as the topology is concerned, the main element to take into account is the model of the cable. The cable used for fix installations is rigid. Generally, rigid cable is used for fix installation because it is cheaper than flexible one, which is used in complement or for extensions for its installation convenience.

In this paper, a new approach based on the reduction of the aperiodic asynchronous impulsive noise emitted by a resistive load commutation is proposed. The signal-to-noise ratio in such a case is improved by controlling the instant of commutation of the load.

The rest of this paper is organized as follow. Section II introduces the commutation system and the way to analyze the noise emitted. Section III presents the results of the commutation. Section IV demonstrates that the response of the impulsive noise is not only due to the commutation instant but also depends on the topology of the network.

II. MEASUREMENT PROTOCOL

The study of the commutation effects of a load is carried out using the schematic presented in figure 2) and described

¹OFDM: Orthogonal Frequency Division Multiplexing.

²PLC: Power Line Communication.

³PHY: Lowest layer in the ISO model network communication.

in the following paragraph.

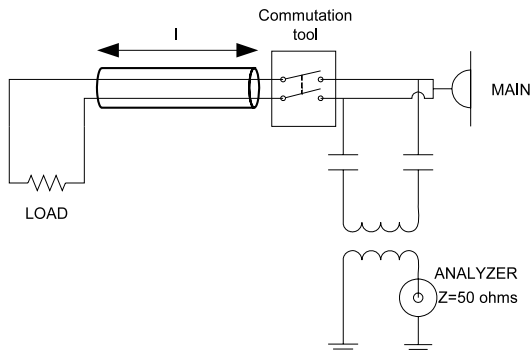

Fig. 2. Analysis of the commutation effects.

A. The cable

Cables installed in buildings do not use a global sheath for the two or three copper conductors. However, a 3G cable (See Table I) was used in order to fix the inter-conductors distance.

TABLE I
CABLE USED FOR THE TEST.

Conductor type	Solid
Manufacturer	La Triveneta Cavi
Reference	U1000 R2V
Class	1, Solid
Insulation (inner / outer)	PR / PVC
Approximated permittivity (inner / outer)	3.18 / 2.25 (Farad/meter)

B. The load and the commutation

The load consists in a 240V / 500 W radiator placed at the end of a cable. This type of load is purely resistive. Its commutation is done using a relay technology. This technology is equivalent to the bilame used in a thermostat of a radiator. A digital dephasing system synchronous to the main is used to evaluate the importance of the instant of the commutation (Fig. 3).

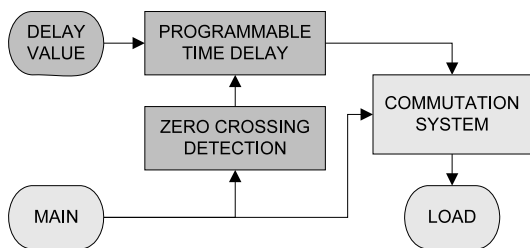

Fig. 3. Commutation tool.

The zero-crossing circuit detects the instant of a zero amplitude value of the main power supply. It is carried out using an optocoupler [11].

At this precise instant, a digital counter implemented in a CPLD⁴ (Xilinx XC9572 [12]) starts counting. A 32.768 kHz system clock increments the counter value asserting a precision of $t \approx 30.5 \mu\text{s}$ on the commutation instant. When the delay value is reached, the desired state of the commutation takes effect.

C. Analysis

The analysis of the channel is carried out using a standard capacitive coupling circuit. The circuit is designed to reject low frequencies (50 Hz), that carry the main power supply. It lets high frequencies passing through. The bandwidth is in the range of 100 kHz to 35 MHz. The analyzer is a dual input acquisition board GAGE CompuScope 12400 [13], with 12 bits of resolution, and sampling at a fixed rate of 200 MHz. Due to such data flow, the on-board memory is used preventing the loss of samples during the acquisition. A hundred times attenuator is used to avoid saturation of the acquisition tool. The input impedance of this attenuator is 50Ω . Signal processing is carried out using MATLAB environment in differed time. The measurement includes an overvoltage protection using a sufficient bandwidth to insure a correct analysis.

In order to reduce the random part of commutation signal and the bounce of contact, ten acquisition sequences are carried out for each parameter (cable length and dephasing value).

III. COMMUTATION ANALYSIS

The time duration of commutation pulses is from $1 \mu\text{s}$ to $50 \mu\text{s}$. In few cases, like in the one presented in figure 4, some bounce can be observed. These bounces are due to the relay technology that has been used for the commutation system. Nevertheless, such bounces can also be observed in a bimetallic commutation employed in the thermostat of a radiator.

A time-frequency analysis is carried out using the Short-Time Fourier Transform (STFT) (Fig. 4). The square modulus of the STFT also called spectrogram is estimated using 1024-points rectangular windows (corresponding to an about $5 \mu\text{s}$ window duration). The 1024-points FFT spectra are evaluated on sliding windows with 95% overlap between the slices.

The time frequency diagram (Fig. 4) clearly demonstrates that during the full pulse duration time, all frequencies, including authorized PLC bandwidth, are perturbed. Moreover, the disturbance duration (from $2 \mu\text{s}$ to $20 \mu\text{s}$) is of the same order than the OFDM symbol duration of PLC standard protocols (from $10 \mu\text{s}$ to $100 \mu\text{s}$). This consideration establishes that the disturbance time and the detection/processing time are equivalent. So, detecting pulses is not efficient. This is why we propose a new approach that controls the instant of commutation, in order to reduce the noise.

⁴CPLD: Complex Programmable Logic Device.

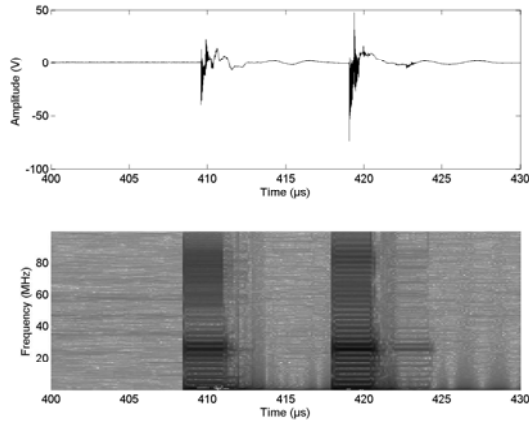

Fig. 4. Time frequency analysis of a commutation.

A. Measurement for a 30-meters cable

Figure 5 presents the noise PSD (Power Spectrum Density) obtained using a Welch periodogram over 2048 samples with a rectangular window and without any overlap in a $75\text{-}\mu\text{s}$ typical OFDM symbol duration. The temporal delay is settled to 0, 12.5 and 25 percent of the power supply period. It respectively corresponds to commute the load when the power supply sinusoidal amplitude is equal to 0%, 70% and 100% of the maximum voltage value. A 30-meters cable is used.

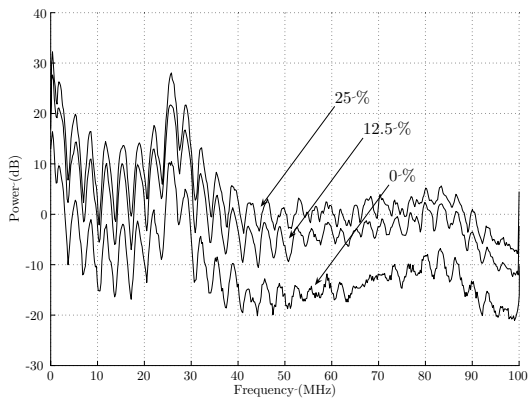

Fig. 5. Comparison of the PSD waveforms as a function of three commutation instants for a 30-meters cable.

Figure 5 shows that the noise floor increases as a function of the delay of the commutation. In order to easily estimate the SNR improvement, an approximation model of the background noise is used [4].

$$N(f) = 10^{a-b \cdot f^c} \text{ (W/MHz)} \quad (1)$$

The fitting curves using MATLAB function are presented in figure 6. The a , b and c parameters are given in table II.

On figure 6, it is obvious that the noise power is included between the noise level given by the curves at 0% and 25%

TABLE II
FITTING CURVES PARAMETERS FOR A 30-METERS CABLE.

Commutation instant	Switched Amplitude	a	b	c
0%	0%	12.1	11.8	0.2
12.5%	70%	22.3	9	0.27
25%	100%	23.9	6	0.35

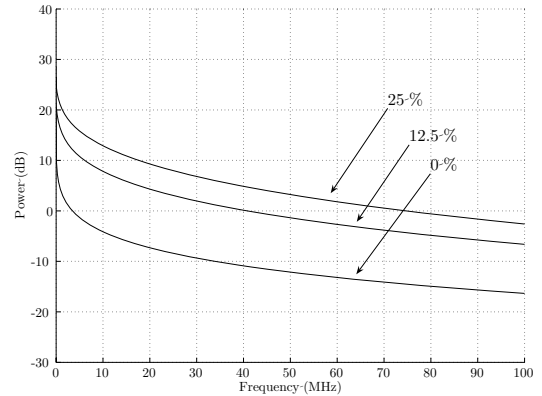

Fig. 6. Fitting curves with respect to the background noise model for a 30-meters cable.

instant commutation. Controlling the instant of commutation permits to fix the noise floor to its lower value. Doing so, the SNR can be improved by about 15 dB in a $75\text{-}\mu\text{s}$ typical OFDM symbol duration.

In order to ensure the independence to the length of the cable, the experimentation is also realized with a 70-meters cable.

B. Measurement for a 70-meters cable

The PSD obtained for a 70-meters cable is presented in figure 7. Figure 8 presents the fitting results.

The PSD and the fitting curves are estimated in the same manner as in section III-A. Table III gives the parameters obtained for the fitting.

TABLE III
FITTING CURVES PARAMETERS FOR A 70-METERS CABLE.

Commutation instant	Switched Amplitude	a	b	c
0%	0%	11.7	13.1	0.19
12.5%	70%	22.4	9.4	0.27
25%	100%	22.7	8.4	0.28

The fitting curves (Fig. 6 and Fig. 8) obtained for a 30-meters and a 70-meters cables show an equivalent behaviour for a given commutation instant. Consequently, controlling the commutation instant may effectively reduce the SNR of about 15 dB, independently of the cable length.

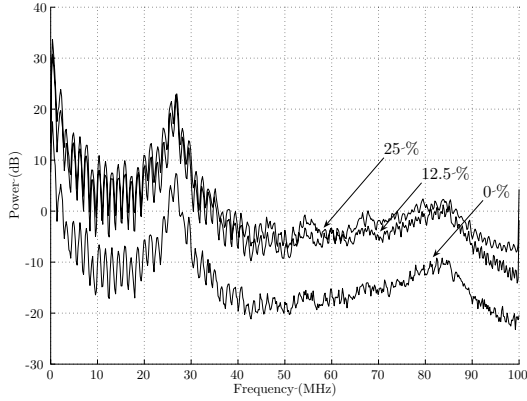

Fig. 7. Comparison of the PSD waveforms as a function of three commutation instants for a 70-meters cable.

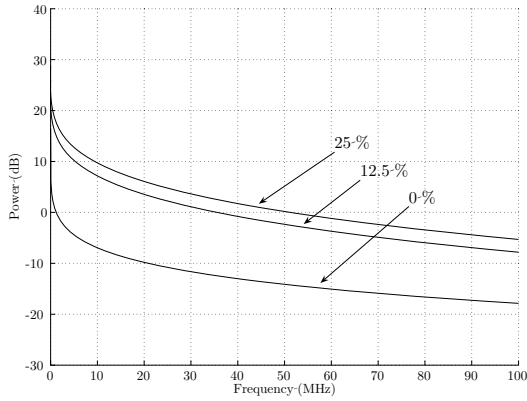

Fig. 8. Fitting curves with respect to the background noise model for a 70-meters cable.

Regarding the figures 5 and 7, we notice ripples. The frequency ripple seems to depend on the cable length. Indeed, the frequency seems to increase with the cable length.

The ripple might be related to the line impedance mismatch.

In order to verify more precisely this hypothesis, a cable analysis is done in the next section.

IV. CABLE ANALYSIS

For this study, the same analysis circuit is employed, but the load is replaced by a generator and the commutation switch is left closed (Fig. 9). The generator is an arbitrary waveform generator (GAGE CompuGen 4300 [14]) using a white noise sampled at the frequency of 300 MHz. The output of the generator matches the full scale input of a line driver (OPA2674) avoiding saturation. Another coupling circuit is added on the line driver output.

The results for a 30-meters, 50-meters and 70-meters cable are presented in figure 10.

The line impedance mismatch will produce reflexions over the line. These reflected signals will be added to the measured signal after a propagation time given by the equation (2).

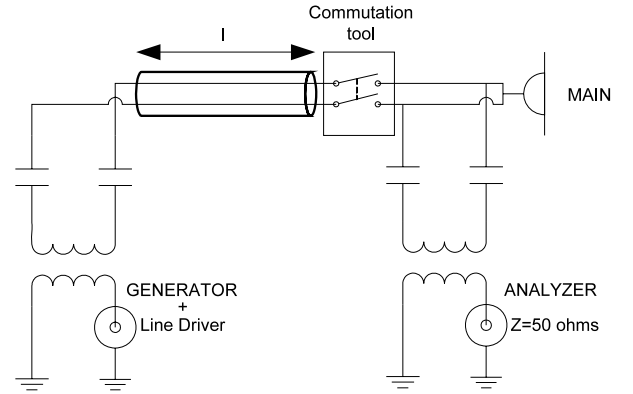

Fig. 9. Method to analyze the bandwidth of the cable.

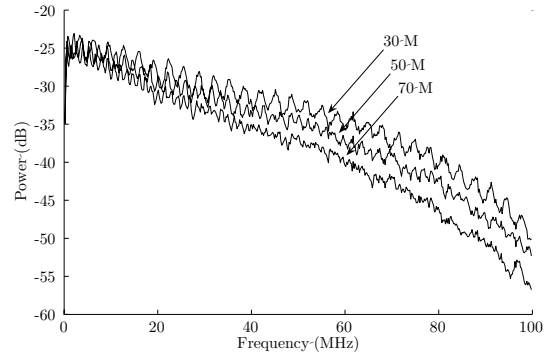

Fig. 10. Ripples in the bandwidth.

$$t_p = \frac{l}{v_p} = \frac{l}{\frac{C}{\sqrt{\epsilon_r}}}, \text{ using } v_p = \frac{C}{\sqrt{\epsilon_r}} \quad (2)$$

where l is the length of the cable, v_p is the propagation speed, $C \approx 3 \cdot 10^8 \text{ m/s}$ is the light speed in vacuum and ϵ_r is the permittivity of the dielectric.

During a propagation time t_p , it is possible to observe a k number of a $\frac{1}{f}$ sinusoidal signal period.

$$t_p = k * \frac{1}{f} \quad (3)$$

A maximum value is obtained in f_k for each integer value of k (4).

$$f_k = \frac{k}{t_p} \quad (4)$$

More over, the frequency distance between two local maxima is ΔF (5).

$$\Delta F = f_{k+1} - f_k = \frac{k+1}{t_p} - \frac{k}{t_p} = \frac{1}{t_p} \quad (5)$$

The measurement permits to evaluate the propagation time for a 50-meters cable and the dielectric cable permittivity using equation (2) giving equation (6).

$$\frac{1}{\Delta F} = t_p = 0.52 \mu s, \quad \sqrt{\epsilon_r} = \frac{C}{L} \approx 3.12 \quad (6)$$

The frequency ripple value (the distance between two local maxima, ΔF) for different cable lengths (0, 20, 30, 50, 70, 80 meters) are measured using zooms like the ones depicted on figure 11.

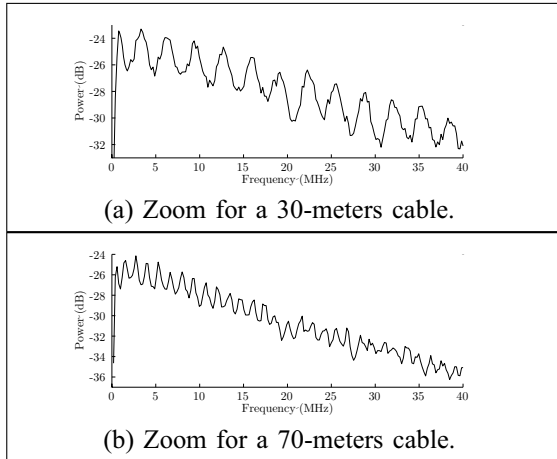

Fig. 11. Zoom on ripples in the bandwidth.

The result is reported in figure 12, where equation (2) is also plotted.

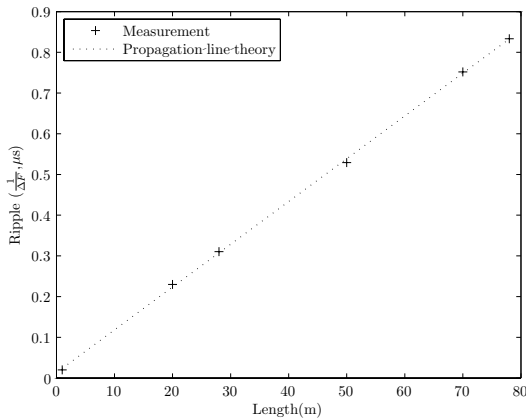

Fig. 12. Ripple ratio as a function of the cable length.

Both curves are superimposed demonstrating that the ripples are really due to the impedance mismatch. The measure of the frequency ripple value in figure 5 and figure 7 also verify the equation (2).

ACKNOWLEDGEMENT

This work has been developed in the frame of the French competitiveness cluster Science and Systems of Electrical (S^2E^2) - SSAME GEDELOC - under the contract n2005-4020-06A-066.

CONCLUSION

In this study we have shown that the noise generated by asynchronous aperiodic impulsive sources can be easily and significantly reduced. Indeed, the SNR, in a 75- μs typical OFDM symbol duration, can be improved from up to 15 dB just by controlling the commutation instant of a resistive load.

Moreover, the asynchronous noise becomes synchronous. The pulses are always located at the zero crossing instant. Therefore, the bit loading can be optimized when the amplitude of the noise remains high. In that case, the data rate is increased, and the synchronization error is less corrupted. This work will be completed soon in both ways: trying different resistive and inductive loads and different network topologies.

REFERENCES

- [1] T. C. Banwell and S. Galli, "A new approach to the modeling of the transfer function of the power line channel," in *ISPLC*, 2001.
- [2] D. Anastasiadou and T. Antonakopoulos, "An experiment setup for characterizing the residential power grid variable behavior," in *ISPLC*, 2002.
- [3] M. Zimmerman, "An analysis of the broadband noise scenario in power-line network," in *ISPLC*, 2000.
- [4] E. Liu, Y. Gao, O. Bilal, and T. Korhonen, "Broadband characterization of indoor powerline channel," in *ISPLC*, 2004.
- [5] M. H. L. Chan and R. W. Donaldson, "Amplitude, width, and interarrival distributions for noise impulses on intrabuilding powerline communication networks," *IEEE Trans. Electromagnetic Compatibility*, vol. 31, no. 3, 1989.
- [6] H. Phillips, "Development of a statistical model for power-line communication channels," in *ISPLC*, 2000.
- [7] S. R. Kim and A. Efron, "Adaptative robust impulse noise filtering," *IEEE Trans. Sig. Proc.*, vol. 43, no. 8, August 1995.
- [8] D. Umehara, S. Hirata, S. Denno, and Y. Morihiro, "Modeling of impulse noise for indoor broadband power line communications," in *ISITA*, 2006.
- [9] M. Wouters, G. Vanwijnsberghe, P. V. Wesemael, T. Huybrechts, and S. Thoen, "Real time implementation on fpga of an ofdm based wireless lan modem extended with adaptive loading," in *ESSCIRC*, 2002.
- [10] C. Dick and F. Harris, "Fpga implementation of an ofdm phy," in *Signals, Systems and Computers*, November 2003, pp. 905–909.
- [11] K. Dostert, *Power-line communications*. New Jersey: Prentice Hall, 2001.
- [12] Cpld xc9572 datasheet. [Online]. Available: http://www.xilinx.com/support/documentation/data_sheets/ds065.pdf
- [13] Gage compuscope 12400 specifications. [Online]. Available: <http://www.gage-applied.com/Products/PDF/compuScope.12400.pdf>
- [14] Gage compugen 4300 specifications. [Online]. Available: <http://www.gage-applied.com/Products/PDF/CG4300-4302.pdf>