



**HAL**  
open science

## A Reconfigurable Multi-core cryptoprocessor for Multi-channel Communication Systems

Michael Grand, Lilian Bossuet, Guy Gogniat, Bertrand Le Gal, Jean-Philippe  
Delahaye, Dominique Dallet

► **To cite this version:**

Michael Grand, Lilian Bossuet, Guy Gogniat, Bertrand Le Gal, Jean-Philippe Delahaye, et al.. A Reconfigurable Multi-core cryptoprocessor for Multi-channel Communication Systems. IPDPS - 25th IEEE International Parallel & Distributed Processing Symposium, May 2011, Anchorage, United States. pp.199-206. hal-00595998

**HAL Id: hal-00595998**

**<https://hal.science/hal-00595998v1>**

Submitted on 26 May 2011

**HAL** is a multi-disciplinary open access archive for the deposit and dissemination of scientific research documents, whether they are published or not. The documents may come from teaching and research institutions in France or abroad, or from public or private research centers.

L'archive ouverte pluridisciplinaire **HAL**, est destinée au dépôt et à la diffusion de documents scientifiques de niveau recherche, publiés ou non, émanant des établissements d'enseignement et de recherche français ou étrangers, des laboratoires publics ou privés.

# A Reconfigurable Multi-core Cryptoprocessor for Multi-channel Communication Systems

Michael Grand<sup>1</sup>, Lilian Bossuet<sup>2</sup>, Guy Gogniat<sup>3</sup>, Bertrand Le Gal<sup>1</sup>, Jean-Philippe Delahaye<sup>4</sup> and Dominique Dallet<sup>1</sup>

<sup>1</sup>IMS Laboratory, University of Bordeaux, firstname.lastname@ims-bordeaux.fr

<sup>2</sup>Hubert Curien Laboratory, University of Lyon, lilian.bossuet@univ-st-etienne.fr

<sup>3</sup>Lab-STICC Laboratory, University of Bretagne Sud, guy.gogniat@univ-ubs.fr

<sup>4</sup>CELAR, DGA, jean-philippe.delahaye@dga.defense.gouv.fr

**Abstract**—This paper presents a reconfigurable *Multi-Core Crypto-Processor* (MCCP) especially designed to secure multi-channel and multi-standard communication systems. Such component meets many constraints like high throughput and flexibility. In contrast, a classical mono-core approach either provides limited throughput or does not allow simple management of multi-channel streams. Nevertheless, parallelism is not sufficient for a multi-standard radio. It is therefore essential to increase MCCP flexibility. To achieve these results, our work takes advantage of the Xilinx FPGA hardware reconfiguration. The proposed MCCP can reach a maximum throughput of 1.7 Gbps at 190 MHz with several AES cipher modes. It uses about 4000 slices on a Virtex 4 FPGA.

**Index Terms**—Software Defined Radio, Crypto-processor, Multi-core

## I. INTRODUCTION

Multiplicity of wireless communication standards (UMTS, WiFi, WiMax) needs highly flexible and interoperable communication systems. Software based solutions such as *Software Defined Radio* (SDR) are used to meet the flexibility constraint. Independently, most of radios have to propose cryptographic services such as confidentiality, integrity and authentication (secure-radio). Therefore, integration of cryptographic services into SDR devices is essential.

By using symmetric cipher and hash function, it is possible to propose such services. However, the use of cryptographic functions in secure systems tends to limit their overall throughput. The best performance is achieved by using dedicated hardware cryptographic accelerator to provide cryptographic services [1], [2]. These cores can reach throughput of tens of gigabits per second using loop unrolling, pipelining and channel interleaving mechanisms. Although, these throughput efficient cores are useful for mono-standard communication systems, they do not provide the level of flexibility needed by multi-standard systems (due to their dedicated architecture). On the contrary, more flexible crypto-processors do not always provide a sufficient throughput for multi-channel applications [19].

To overcome these issues, this paper presents a reconfigurable *Multi-Core Crypto-Processor* (MCCP) especially designed to provide both flexibility and high throughput in order to secure multi-standard and multi-channel communication streams. To achieve these results, the MCCP architecture is

a trade-off between a throughput efficient design and a multi-mode design. Moreover, its modular and reconfigurable design (by using FPGA hardware reconfiguration) allows to use any 128-bit block cipher algorithm (e.g. AES, Twofish, Serpent, ...). In this paper, the AES algorithm is used as an illustration. This architecture, which provides a maximum throughput of 1.7 Gbps at 190 MHz on a Virtex4 FPGA, supports most of the block cipher modes of operation such as CTR, CCM, GCCM and CBC-MAC.

The paper is organized as follows: Section 2 introduces multi-channel and multi-standard issues to choose suitable computing architecture. Section 3 presents the top level architecture of the proposed MCCP. Sections 4 and 5 detail the lower layers of the MCCP architecture (i.e. *Cryptographic Core* and *Cryptographic Unit*). MCCP operation is explained in section 6 using some didactic examples, according to these examples section 7 provides experimental results. Section 8 discusses the implementation of MCCP operating system. Finally, section 9 concludes this paper.

## II. CRYPTOGRAPHIC ARCHITECTURE DESIGN FOR INTENSIVE COMMUNICATION SYSTEMS

### A. Design Constraints

The design of a multi-standard and multi-channel secure SDR faces two main constraints:

- A multi-**standard** secure SDR has to provide several cryptographic algorithms.
- A multi-**channel** secure SDR device handles two or more communication channels at the same time.

In consequence, designers have to choose a trade-off between flexibility, throughput performance and area cost. In this paper, a loosely coupled multi-core crypto-processor is presented as an alternative to mono-core crypto-processors and tightly coupled multi-core crypto-processors. This architecture is designed to improve the flexibility/performance trade-off of communication crypto-processors. The next part briefly describes previously published works dealing with hardware cryptographic architectures.

### B. Previous Works

The best performance (in terms of throughput) are provided by pipelined cryptographic accelerators. In such cores,

encryption algorithm is fully unrolled to produce an efficient pipelined design. For example, GCM (*Galois Counter Mode* [7]) is especially designed to take profit of pipelined cores. There are several works dealing with hardware implementations of AES-GCM core. [1], [11], [12] are few examples of such implementations which allow throughput of tens of gigabits per second. But, this kind of architecture has several drawbacks.

Firstly, algorithm unrolling leads to high hardware resource consumption. Secondly, data dependencies in some block cipher modes (e.g. CCM for *Counter with CBC-MAC Mode* [6]) make unrolled implementations useless. Finally, complex designs are needed when multiplexed channels use different standards. In consequence, pipelined cores are better suited for mono-standard radio than for multi-standard ones.

In contrast, accelerators based on iterative architectures provide a maximum throughput for a minimum cost. In addition, iterative architectures are compliant with all block cipher modes of operation. However, their maximum throughput is still limited if compared to pipelined core throughput [19]. To solve this problem, several multi-core accelerators have been developed. For example, [3], [13], [14] use two AES sub-cores in order to increase the CCM mode throughput. It is noteworthy that sub-cores are tightly coupled and therefore, they cannot work independently.

A more flexible approach uses programmable crypto-processor architectures. Such architectures give priority to flexibility at the expense of throughput. Nevertheless, programmable architecture often exhibits a degree of parallelism in order to increase throughput. For example, Celator [15] is a programmable crypto-processor composed of several *Processing Elements* (PE). Celator PEs are connected together to form a matrix like a block cipher state variable. According to PE configuration, cryptographic functions are applied on the value stored in each PE. Celator is able to compute AES, DES or SHA algorithms, providing for example a throughput of 46 Mbps at 190 MHz when computing AES-CBC algorithm.

An other example is Cryptonite [4]. It is a programmable VLIW crypto-processor that supports AES, DES, MD5 and others cryptographic algorithms. Cryptonite is built around two clusters. Each cluster provides cryptographic functions used by block cipher algorithms. This implementation targets ASIC platform and reaches a throughput of 2.25 Gbps at 400 MHz for the AES-ECB algorithm.

Anyway, all these architectures exhibit tightly coupled parallelisms (i.e. pipelined architecture, VLIW architecture) that need the use of complex software to handle efficiently multi-channel and multi-standard packet streams. In contrast, the Cryptomaniac architecture [16] has been especially designed to take into account multi-channel and multi-standard issues. Indeed, this processor is based on a loosely coupled multi-crypto-processor architecture (crypto-processors can operate independently of each others) where a scheduler core dispatches incoming packets to several simple crypto-processors.

In this paper, a loosely coupled and reconfigurable multi-crypto-processor architecture is presented. Such architecture

provides high performance by using dedicated programmable crypto-processors while it remains flexible by the use of FPGA hardware reconfiguration. Hence, performance/flexibility trade-off is improved compared to Cryptomaniac fixed architecture.

### III. MULTI-CORE CRYPTO-PROCESSOR ARCHITECTURE

#### A. General Architecture

Our crypto-processor (Fig. 1) is built around one task scheduler and several programmable *Cryptographic Cores*. However, the proposed architecture targets FPGA platform to be as flexible as software components embedded in SDR. By this way, our Multi-Core Crypto-Processor (MCCP) can be updated for security or interoperability reasons. Also, MCCP can take profit of new FPGA partial reconfiguration capabilities to reduce resource consumption and increase its flexibility.

The MCCP is embedded in a much larger platform including one main controller and one communication controller which manages communications going through the radio [17]. MCCP does not generate session keys itself. Keys are generated by the main controller and stored into a dedicated memory. The MCCP is used as a red/black boundary and it provides all necessary cryptographic services needed by an SDR (e.g. secure SCA [18]). MCCP architecture is scalable; the number of embedded crypto-core may vary. A four-core architecture has been implemented (Fig. 1). However, more or less than four cores may be implemented according to the communication system requirements.

Proposed MCCP embeds one *Task Scheduler* which distributes cryptographic tasks to *Cryptographic Cores*. The *Task Scheduler* is implemented using a simple 8-bit controller which executes the task scheduling software. It manages the *Key Scheduler*, the *Cross Bar* and the *Cryptographic Cores*. *Task Scheduler* receives its orders from a 32-bit *Instruction Register* and returns values to the communication controller through the 8-bit *Return Register*. Some signals (*Start* and *Done*) are used to synchronize instruction execution.

Each *Cryptographic Core* communicates with the communication controller through the *Cross Bar*, it enables the *Task Scheduler* to select a specific core for I/O access. The *Key Scheduler* generates round keys from the session key stored in the *Key Memory*. Before launching the key scheduling, the *Task Scheduler* loads the session key ID into the *Key Scheduler* which gets the right session key from the *Key Memory*. To improve system security, the *Key Memory* cannot be accessed in write mode by the MCCP. In addition, there is no way to get the secret session key directly from the MCCP data port.

*Cryptographic Core* architecture is further detailed in the Section 4, the next part deals with the MCCP control protocol.

#### B. MCCP Control Protocol

As it was explained above, the MCCP receives instructions from the communication controller through the control port. Current release of the MCCP takes a 32-bit instruction as input and returns an 8-bit value as output. Available instruction set

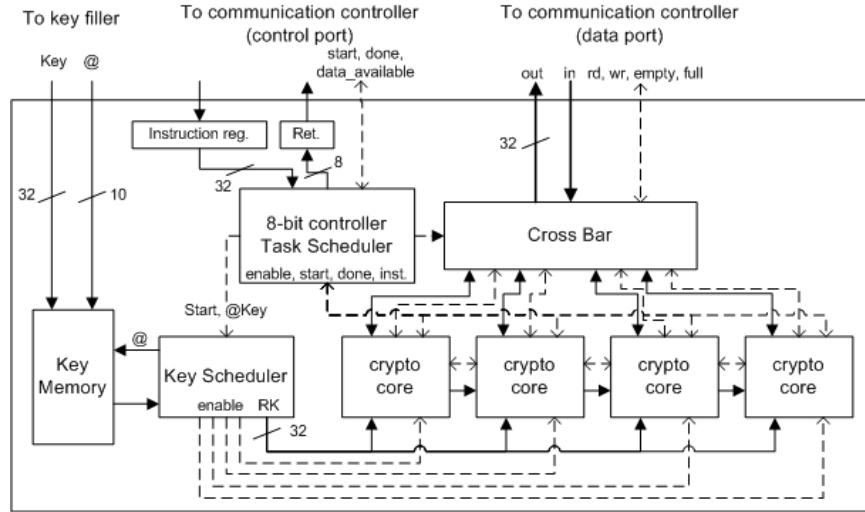

Fig. 1. The M CCP Architecture

allows users to open, close, encrypt or decrypt data packets. When data are available on *Crypto Core* output FIFOs, the *Task Scheduler* sends a *Data Available* interruption signal to the communication controller. Once data have been read, the TRANSFER DONE instruction closes the connection.

M CCP executes an instruction in four, non interruptible, steps which are: 1) Write an instruction into the Instruction Register, 2) send a start signal, 3) wait for done signal to be triggered, 4) read returned value from the Return Register. The following list details the available instruction set:

- **OPEN Algorithm, Key ID:** This instruction is used to open a new channel on the M CCP. It returns either an *OK flag* and a *Channel ID* or an error code.
- **CLOSE Channel ID:** This instruction is used to close an open channel. It returns either an *OK flag* or an error code.
- **ENCRYPT Channel ID, Header Size, Data Size:** This instruction is used to encrypt data with a chosen channel. *Header Size* and *Data Size* correspond respectively to the authenticated only data size and plaintext data size. Before triggering the done signal, the *Task Scheduler* opens a core fifo in write mode to allow data transmission. It returns either an *OK flag* and a *Request ID* or an error flag if no more resources are available.
- **DECRYPT Channel ID, Header Size, Data Size:** This function works as an inverse-ENCRYPT instruction, since it provides decryption services. It returns either an *OK flag* and a *Request ID* or an error flag if no more resources are available.
- **RETRIEVE\_DATA:** This instruction is used to retrieve data once the *Data Available* signal has been caught by the communication controller. It returns either an *OK flag* or an *AUTH\_FAIL* flag if data have not been authenticated. The *Request ID* of the corresponding ENCRYPT/DECRYPT request is also returned. In addition, this instruction configures the *Cross Bar* to enable I/O

access when an *OK flag* has been returned.

- **TRANSFER\_DONE:** This instruction is used to inform the M CCP that all data have been uploaded/downloaded from/into the fifo after execution of an ENCRYPT, a DECRYPT or a successful RETRIEVE\_DATA instruction.

### C. Task Mapping

In the current release of our architecture, incoming packets are processed in their order of arrival as fast as possible. In consequence, no scheduling algorithm are involved in packet processing. Such behaviour allows to maximize the M CCP throughput at the expense of latency in packet processing. However, minimizing latency is essential for real time applications (e.g. voice and video transmission) so this issue will be studied in further works.

Currently, when the *Task Scheduler* receives either an ENCRYPT or a DECRYPT instruction, an incoming packet is forwarded to the first idle core found. If no core is available, it returns an error flag. The improvement of the task mapping algorithm is discussed at the end of this paper.

## IV. CRYPTOGRAPHIC CORE

### A. Cryptographic Core Architecture

Architecture of *Cryptographic Core* is presented on figure 2. On this schematic, dashed lines represent control signals. Each *Cryptographic Core* communicates with the communication controller and other cores through two FIFOs ( $512 \times 32$ bits) and one *Shift Register* ( $4 \times 32$ bits). Cryptographic functions are implemented in the *Cryptographic Unit* and they can be used through the *Cryptographic Unit Instruction Set Architecture*. Cipher round keys are pre-computed and stored in the *Key Cache*. An *8-bit Controller* generates instruction flow according to the selected block cipher mode. To save resources, it shares its double port instruction memory with its right neighbouring *Cryptographic Core*.

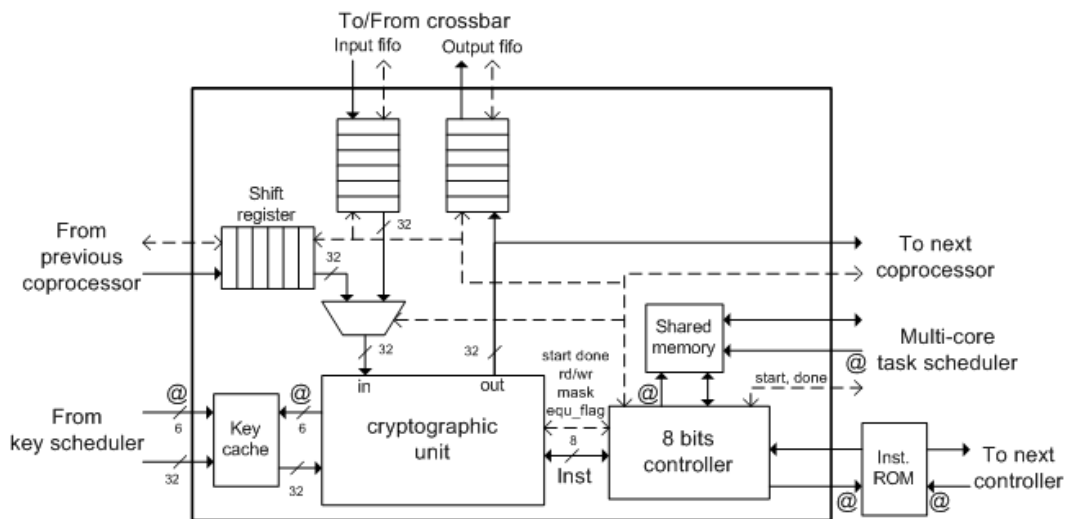

Fig. 2. Cryptographic Core Architecture

Inter-*Cryptographic Core* ports are used to convey temporary data from a core to another. For example, in the case of the CCM mode, the MAC value returned by the CBC-MAC mode needs to be encrypted using the CTR mode. When CBC-MAC and CTR algorithms are computed on two different cores, the inter-*Cryptographic Core* ports is used to forward the MAC value from the CBC-MAC core to the CTR core.

### B. Cryptographic Core 8-bit Controller Design

As said above, *Cryptographic Core* handles several block cipher operation modes leading to complex control state machines. A more flexible approach is to use a general purpose simple controller to generate instruction flows executed by each *Cryptographic Unit*. Use of such controller allows us to simplify execution of loop conditions for packet encryption/decryption. Because this controller does not perform heavy computations, we use an 8-bit controller providing a simple instruction set. It communicates with the *Task Scheduler* to receive orders and return execution results.

At prototyping step, a modified 8-bit Xilinx PicoBlaze controller [20] has been used. It embeds a  $16 \times 8$ -bit register and some arithmetic and logic operators. Each instruction takes two clock cycles to be executed and its instruction memory size is limited to  $1024 \times 18$ -bit instructions stored into one FPGA ram block. In addition, this controller supports interruption handling. To finish, a custom HALT instruction is used to put the controller into a sleep mode after an instruction is sent to the *Cryptographic Unit*. The controller wakes up when the *Cryptographic Unit* triggers the *done* signal.

### C. Packet Processing

Incoming packets are processed in the following way: 1) The *Task Scheduler* sends an instruction to the 8-bit Controller through the shared memory and triggers a *start* signal. 2) The 8-bit Controller starts pre-computations needed by the selected algorithm and loads data from input FIFO once there are

available. 3) Data are processed by blocks of 128 bits and filled into the output FIFO. 4) When all data have been processed, the 8-bit Controller sends a *done* signal to the *Task Scheduler*. In order to protect master processor from software attacks (e.g. eavesdropping, spoofing, splicing), output FIFO is re-initialized if plaintext data does not match the authentication tag. Each FIFO can store a packet of 2048 bytes of data which is sufficient for most of communication protocols.

### D. The Available Operation Modes

MCCP can execute GCM, CCM, CTR, CBC-MAC block cipher modes of operation. Available rules for implemented modes of operation are described below:

- Packets from a same channel can be concurrently processed with different *Cryptographic Core*.
- Packets from different channels can be concurrently processed with different *Cryptographic Core*.
- Any single packet can be processed on any single *Cryptographic Core*.
- Using inter-core communication port, any single CCM packet can be processed with two *Cryptographic Cores*.

Right mode of operation is selected by the *Task Scheduler* according to requested channel algorithm and available resources. As it is said above, a smartly designed *Task Scheduler* software must be implemented to use available resources in an efficient way. Further details are given in Section VIII.

## V. RECONFIGURABLE CRYPTOGRAPHIC UNIT

### A. Cryptographic Unit Architecture

*Cryptographic Unit* (Fig. 3) provides low level cryptographic primitives. It works sequentially on 128-bit words over a 32-bit datapath. For figure 3 example, a *Cryptographic Unit* embeds a 32-bit AES core, a GHASH core and some arithmetic and logic operators (XOR, adder, comparator). By this way, it can provide support for most block cipher encryption algorithms. In addition, *Cryptographic Unit* embeds an

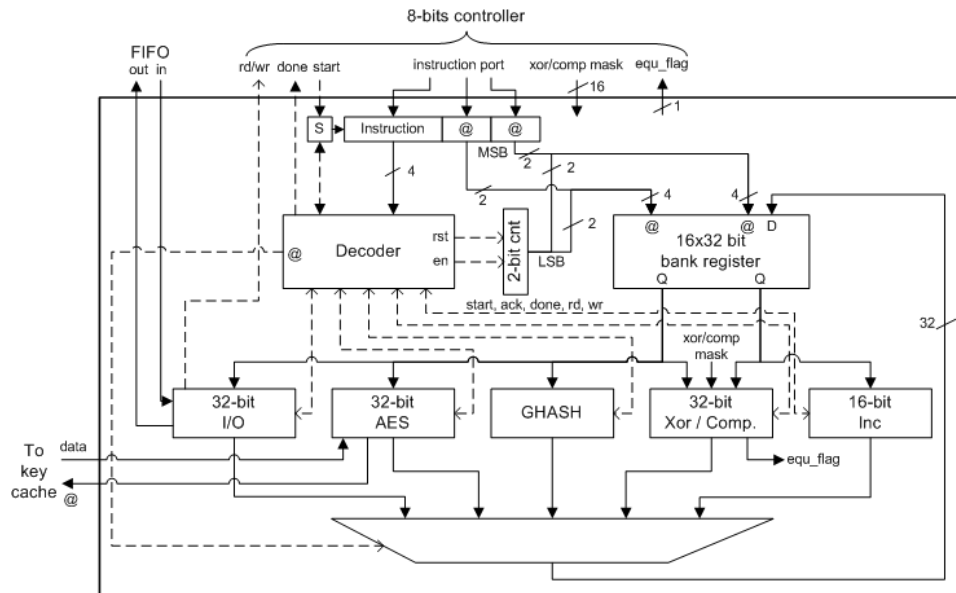

Fig. 3. The Cryptographic Unit Architecture

*Instruction Decoder* and  $4 \times 128$  bits Bank Register. A 2-bit counter is also used in order to sequentially reach each four 32-bit sub-word of a Bank Register 128-bit word. A one bit register, *S register*, is used as a start flag.

On figure 3 example, AES and GHASH cores are both compact cores presented in some previously published works. *AES core* was developed using P. Chodowiec and K. Gaj work [19] for FPGA devices. Because AES-CCM and AES-GCM modes only use encryption mode, AES decryption algorithm was not implemented. AES core is implemented using an iterative architecture and the SubBytes transformation [5] uses look up tables. Iterative architecture implies that AES computation time is key size dependant. Computation of one 128-bit block takes 44, 52 or 60 cycles when using respectively 128-bit, 192-bit or 256-bit key sizes.

*GHASH core* is based on digit-serial multiplier architecture described in [1]. Digit-serial multiplication is made using 3-bit digits and it is computed in 43 clock cycles. 32-bit Xor/Comparator processing core takes two 16-byte words as input. According to the selected operation mode, it computes either  $B = (A \oplus B) \cdot mask$  or set *equ\_flag* to 1 if previous result is null. *Mask* value is a 16-bit word which allows user to mask specific bytes of XOR result.

*Inc Core* allows 16-bit incrementation by 1, 2, 3 or 4 of a 128-bit word. Finally, *32-bit I/O core* manages the communications between FIFOs and the Bank Register.

### B. Cryptographic Unit Operation

*Cryptographic Unit* instructions are executed in seven clock cycles from start signal rising edge to done signal falling edge. For example, XOR execution steps are detailed below:

- 1) When *Start* signal goes high, instruction port value is sampled into the dedicated input register and the *S* register is set to 1 (i.e. start flag).

- 2) Decoder immediately decodes the loaded instruction and sends a start signal from the *S* register to the right processing core start input (i.e. *ghash\_start\_init*, *ghash\_start\_finalize*, ...). Also, decoder redirects right processing core output to the bank register input and grants read/write access to this core.
- 3) Processing core sends an *Ack* signal which validates that *Start* signal has been taken into account by resetting the *S* register.
- 4) Processing cores *rd* and/or *wr* signals go high while data are processed. A high level on *rd* or *wr* signals automatically increments the 2-bit counter in order to sequentially reach each 32-bit sub-word of a Bank Register word. The accessed words are selected by the two address fields of the instruction register.
- 5) Once computations are finished a *done* signal is sent by the processing core to the 8-bit Controller.

Some instructions have a more complex behaviour, the following part deals with the *Cryptographic Unit* instructions and their particularities.

### C. Instruction Set Architecture

Each *Cryptographic Unit* is controlled thanks to a specific instruction set which is detailed in Table 1. This instruction set provides I/O instructions and low level cryptographic functions such as AES encryption and GHASH algorithm. The 8-bit instructions are composed of a 4-bit operation code and two 2-bit addresses used to address the bank register.

The use of *start instructions* (i.e. SGFM and SAES) and *finalize instructions* (i.e. FGFM and FAES) enables AES and GHASH algorithms to be computed in background while others instructions (e.g. INC, XOR, ...) are executed. Such mechanism allows to save computation time and therefore improves throughput.

<i>LOAD @A</i>	Loads a 128-bit word into the A register.
<i>LOADH @A</i>	Loads the computed H constant into the GHASH core.
<i>SGFM @A</i>	Computes one iteration of the GHASH algorithm.
<i>FGFM @A</i>	Stores the result of the GHASH algorithm into the A register.
<i>SAES @A</i>	Encrypts the value stored in the A register.
<i>FAES @A</i>	Stores the results of the SAES computation into the A register.
<i>INC @A, I</i>	Increments by I the 16 less significant bits of the A register, where I is a 2-bit natural.
<i>XOR @A, @B</i>	Computes $B = (A \text{ XOR } B) \text{ AND } \textit{mask}$ .
<i>EQU @A, @B</i>	Sets the <i>equ_flag</i> to 1 if $A = B$ and 0 else.

TABLE I  
THE CRYPTOGRAPHIC UNIT ISA

## VI. IMPLEMENTATION OF CRYPTOGRAPHIC ALGORITHMS

### A. General Implementation Rules

Cryptographic algorithms executed by proposed MCCP are implemented with Xilinx PicoBlaze assembler language which is used to generate the *Cryptographic Unit* instruction flow. *Cryptographic Unit* instruction is executed in three steps: firstly, the *Cryptographic Unit* instruction is fetched in the controller, secondly the instruction is written in the *Cryptographic Unit* instruction port and finally the controller waits for execution completion. Performances can be enhanced by pre-fetching the *Cryptographic Unit* instruction before algorithm execution.

Fetching and pre-fetching steps are made using a *LOAD* instruction which loads an 8-bit value into the controller bank register. Execution step is made using an *OUTPUT* instruction which writes an 8-bit value from the bank register to the controller output port. The *8-bit Controller* write strobe signal is connected to the *Cryptographic Unit* start input. To finish, a *HALT* instruction is used to put the controller in sleep mode until the end of the execution step. Because all the *Cryptographic Unit* instructions, except *FAES* and *FGFM*, have a fixed execution time, a *HALT* instruction may be replaced by two *NOP* instructions. In this case, the controller does not wait for the predictable *done* signal and one clock cycle can be saved.

### B. Implementation of Block Cipher Modes of Operation

Cryptographic tasks attribution is made in the following way. Firstly, the *Task Scheduler* selects the cores which will execute the task and generates the needed round keys, then it sends channel and packet parameters to the core (including the algorithm ID, the authenticated only field size, the plaintext field size and the tag length for authenticated channel), finally the *Task Scheduler* sends a *start* signal to the cores.

Once an *ENCRYPT/DECRYPT* instruction has been taken into account, the communication controller sends data into the cores input fifos. Data must be sent in a specific way to be correctly interpreted by the cores. At first, algorithm IV must be filed into the FIFO, then packet data must be filed. To finish, communication controller must append a message authentication tag. *Cryptographic Unit* only embeds basic operators in addition to *AES* and *GHASH* cores, therefore it cannot be used to format the plain text according to the specifications of block cipher modes of operation. In consequence,

the communication controller must format data prior to send them to the cryptographic cores.

FIFO buffers can store up to 128 plaintext blocks, so cryptographic algorithm main loops are critical parts of their implementations. Listing 1 shows an example of a piece of code used by cryptographic cores to compute the GCM algorithm main loop. This listing shows how instructions are placed between *SAES* and *SGFM* instruction in order to save clock cycles. In this example, *OR* instructions are used as *NOP* instructions. To finish, algorithm performances and other results are detailed in the following section.

GCMloop:	OUTPUT	FAES, inst	
	HALT	DISABLE	
	OUTPUT	SAES, inst	
	OR	s0, FF	;NOP
	OR	s0, FF	;NOP
	OUTPUT	IXOR, inst	
	OR	s0, FF	;NOP
	OR	s0, FF	;NOP
	OUTPUT	SGFM, inst	
	HALT	DISABLE	
	OUTPUT	STORE, inst	
	OR	s0, FF	;NOP
	OR	s0, FF	;NOP
	OUTPUT	INC, inst	
	OR	s0, FF	;NOP
	OR	s0, FF	;NOP
	OUTPUT	LOAD_PT, inst	
	SUB	dlength, 01	
	JUMP	NZ, GCMloop	

Listing 1. GCMloop Body

## VII. RESULTS

### A. Implementation Results

Proposed MCCP has been described with VHDL and synthesized using Xilinx ISE Tool. For MCCP hardware implementation, we use a Xilinx Virtex 4 SX35-11 FPGA. With this device, MCCP is able to reach a frequency of 190 Mhz. Only 4084 slices and 26 BRAMs are used.

At lowest level, overall throughput is limited by *AES* core computation time which depends on *AES* key size. But, at higher level, throughput is limited by the main loops of block cipher modes. The computation time of these loops may be used to calculate a theoretical maximum throughput for each algorithm. Loop computation times, in cycles, for 128-bit *AES-GCM* and *AES-CCM* are equal to:

$$\begin{aligned}
 T_{GCMloop} &= T_{CTR} = T_{SAES} + T_{FAES} = 49 \\
 T_{CCMloop\_2cores} &= T_{CBC} = T_{SAES} + T_{FAES} + T_{XOR} = 55 \\
 T_{CCMloop\_1core} &= T_{CTR} + T_{CBC} = 104
 \end{aligned}$$

Height cycles must be added to these values for 192-bit keys and height more cycles must be added for 256-bit keys. Then, pre and post loop computations must be taken into account in order to obtain a realistic throughput. It is noticeable that actual throughput depends on packet size, higher throughputs are obtained from larger packets. Table II summarizes these results. For each table II column, the first number denotes the theoretical throughput calculated from loops computation time, while the second number corresponds to the processing time of a 2 KB packet.

Table II shows that AES-CCM  $4 \times 1$  cores (4 packets on 4 different cores) provides better throughput than AES-CCM  $2 \times 2$  cores (2 packets on 4 cores). This means that packet processing on one core is more efficient than packet processing on two cores. However, latency of the first solution is almost two times greater than latency of the second solution. As a consequence, designers should make scheduling choices according to system needs in terms of latency and/or throughput.

Table III compares architecture performances (i.e. functionalities, area, and throughput) of literature approaches to the proposed one. This table shows that our architecture provides better performances, at the same frequency, than other programmable architectures, while it is still competitive when it is compared to non programmable architectures. In consequence, MCCP architecture seems to provide a good trade-off between flexibility and throughput. The next section presents some preliminary results about MCCP partial reconfiguration.

### B. MCCP Partial Re-configuration Preliminary Results

Even if design methodology is not yet mature, most of newest FPGA (Xilinx and Altera) are partially reconfigurable. MCCP flexibility can be further improved through partial reconfiguration of the *Cryptographic Unit*. At the time of writing this paper, we implemented partial reconfiguration on a Xilinx Virtex 4 FPGA. Implemented cryptographic algorithms are the AES encryption algorithm and the Whirlpool hashing algorithm. The reconfigurable area embeds 1280 slices and 16 BRAM. Table IV details the measured preliminary results.

Core	AES Encryption (with KS)	Whirlpool
Slices (BRAM)	351 (4)	1153 (4)
Bitstream Size (kB)	89	97
Reconfiguration Time (from compact flash) (ms)	380	416
Reconfiguration Time (from RAM) (ms)	63	69

TABLE IV  
PARTIAL RECONFIGURATION RESULTS

Reconfiguration time results show that caching of bitstream is needed to obtain the best performances. In addition, magnitude of the reconfiguration times does not allow to consider real-time partial reconfiguration. However, partial reconfiguration may be used for occasional reconfigurations. For example, in a first time, a key exchange algorithm may be loaded into the *Cryptographic Unit* then, in a second time, a data encryption

algorithm may be loaded. In addition, the reconfiguration of one part of the FPGA does not prevent others parts to work. This is valuable in the case of on-line hardware updates for example.

## VIII. DISCUSSION

Like with classical MPSoC, to allow maximum throughput, incoming data streams have to be assigned to idle *Cryptographic Cores*. Similarly, *Cryptographic Cores* have to be released after a stream has ended. The assignment procedure has also to cover loading of the correct *Cryptographic Core* program and *Cryptographic Unit* configuration. Besides simple assignment of streams to idle *Cryptographic Cores*, it must also be possible to prioritize certain streams over others to allow some sort of quality-of-service. Nevertheless, system security has to be continually enforced. As a consequence, significant works have to be done to develop secure operating system able to manage stream assignment and MCCP reconfiguration.

## IX. CONCLUSION AND FUTURE WORKS

This work shows that the multi-core architecture presented in this paper provides a good trade-off between flexibility and throughput. Flexibility and performances are obtained by using a hybrid design where low level cryptographic primitives are implemented in hardware while high level block cipher modes are implemented in software. Its 1.7 Gbps throughput makes it particularly suitable for medium rate multi-channel communication systems. Proposed MCCP supports CTR, CBC-MAC, CCM and GCM block cipher modes which are commonly used in communication systems. AES core may be easily replaced by any other 128-bit block cipher (such as Twofish) according to the user needs. It is noticeable that partial reconfiguration, may be used to do this task.

In future works, task scheduling will be improved and partial reconfiguration will be fully implemented to obtain a highly flexible and efficient architecture.

## ACKNOWLEDGEMENT

This work is in part supported by the French DGA (General Armaments Directorate) and by the University of Bordeaux. The views expressed in this paper are those of the authors and cannot be regarded as stating an official position of the DGA or the French DoD.

## REFERENCES

- [1] S. Lemsitzer, J. Wolkerstorfer, N. Felber, and M. Braendli, "Multi-gigabit gcm-aes architecture optimized for fpgas," in *CHES '07: Proceedings of the 9th international workshop on Cryptographic Hardware and Embedded Systems*. Berlin, Heidelberg: Springer-Verlag, 2007, pp. 227–238.
- [2] A. Hodjat and I. Verbauwhede, "Area-throughput trade-offs for fully pipelined 30 to 70 gbits/s aes processors," *IEEE Transactions on Computers*, vol. 55, pp. 366–372, 2006.
- [3] A. Aziz and N. Ikram, "An fpga-based aes-ccm crypto core for ieee 802.11i architecture," *I. J. Network Security*, vol. 5, no. 2, pp. 224–232, 2007.
- [4] R. Buchty, N. Heintze, and D. Oliva, "Cryptonite - a programmable crypto processor architecture for high-bandwidth applications," in *Organic and Pervasive Computing - ARCS 2004*, ser. Lecture Notes in Computer Science, S. B. . Heidelberg, Ed., vol. 2981/2004, 2004, pp. 184–198.



Key Size (bit)	AES-GCM (Mbps)		AES-CCM (Mbps)			
	1 core	4 × 1 cores	1 core	4 × 1 core	2 cores	2 × 2 cores
128	496 / 437	1984 / 1748	233 / 214	932 / 856	442 / 393	884 / 786
192	426 / 382	1704 / 1528	202 / 187	808 / 748	386 / 348	772 / 696
256	374 / 337	1496 / 1348	178 / 171	712 / 684	342 / 313	684 / 626

TABLE II  
MCCP ENCRYPTION THROUGHPUTS AT 190 MHz (THEORETICAL/2 KB PACKET)

Implementation	Platform	Programmable	Algorithm	Throughput (Mbps/MHz)	Frequency (MHz)	Slices (BRAMs)
Cryptonite [4]	ASIC	Yes	ECB	5.62	400	—
Celator [15]	ASIC	Yes	CBC	0.24	190	—
Cryptomaniac [16]	ASIC	Yes	ECB	1.42	360	—
A. Aziz et al. [3]	x3s200-5	No	CCM	2.78	247	487 (4)
S. Lemsitz et al.[1]	v4-FX100	No	GCM	32.00	140	6000 (30)
Our work	v4-SX35-11	Yes (AES modes)	GCM/CCM	9.91 / 4.43	190	4084 (26)

TABLE III  
PERFORMANCE COMPARISON

- [5] *FIPS-197*, NIST Std., 2001. [Online]. Available: <http://csrc.nist.gov/>
- [6] *Special Publication 800-38C*, NIST Std., 2004. [Online]. Available: <http://csrc.nist.gov/>
- [7] *Special Publication 800-38A*, NIST Std., 2001. [Online]. Available: <http://csrc.nist.gov/>
- [8] *FIPS 113*, NIST Std., 1985.
- [9] D. Whiting, R. Housley, and N. Ferguson, "Counter with cbc-mac (ccm), submission to nist," NIST, Tech. Rep., 2002.
- [10] *Special Publication 800-38D*, NIST Std., 2007. [Online]. Available: <http://csrc.nist.gov/>
- [11] A. Satoh, Takeshi, and T. Aoki, "High-speed pipelined hardware architecture for galois counter mode," in *Information Security*, ser. Lecture Notes in Computer Science, S. B. . Heidelberg, Ed., vol. 4779/2007, 2007, pp. 118–129.
- [12] S. Wang, "An architecture for the aes-gcm security standard," Master's thesis, University of Waterloo, 2006.
- [13] K. Vu and D. Zier, "Fpga implementation aes for ccm mode encryption using xilinx spartan-ii," Oregon State University, Tech. Rep., 2007.
- [14] E. López-Trejo, F. Rodríguez-Henríquez, and A. Díaz-Pérez, "An fpga implementation of ccm mode using aes," in *ICISC*, 2005, pp. 322–334.
- [15] D. Fronte, A. Perez, and E. Payrat, "Celator: A multi-algorithm cryptographic co-processor," in *Proc. International Conference on Reconfigurable Computing and FPGAs ReConFig '08*, Dec. 3–5, 2008, pp. 438–443.
- [16] L. Wu, C. Weaver, and T. Austin, "Cryptomaniac: a fast flexible architecture for secure communication," in *ISCA '01: Proceedings of the 28th annual international symposium on Computer architecture*. New York, NY, USA: ACM, 2001, pp. 110–119.
- [17] M. Grand, L. Bossuet, G. Gogniat, B. L. Gal, and D. Dallet, "A reconfigurable crypto sub system for the software communication architecture," in *Proceedings MILCOM2009*, 2009.
- [18] *Security Supplement to the Software Communications Architecture Specification*, April 30, 2004, JTRS Std. 2.2.1, April 2004. [Online]. Available: <http://sca.jpeojtrs.mil/>
- [19] P. Chodowicz and K. Gaj, "Very compact fpga implementation of aes algorithm," in *CHES 2003*. Berlin Heidelberg: Springer-Verlag, 2003, pp. 319–333.
- [20] Picoblaze user resources. Xilinx. [Online]. Available: <http://www.xilinx.com>