



**HAL**  
open science

## Design of a Very Low-power, Low-cost 60 GHz Receiver Front-End Implemented in 65 nm CMOS Technology

Michael Kraemer, Daniela Dragomirescu, Robert Plana

► **To cite this version:**

Michael Kraemer, Daniela Dragomirescu, Robert Plana. Design of a Very Low-power, Low-cost 60 GHz Receiver Front-End Implemented in 65 nm CMOS Technology. *International Journal of Microwave and Wireless Technologies*, 2011, 3 (Special Issue 2), p.131-138. 10.1017/S1759078711000067. hal-00591033

**HAL Id: hal-00591033**

**<https://hal.science/hal-00591033v1>**

Submitted on 6 May 2011

**HAL** is a multi-disciplinary open access archive for the deposit and dissemination of scientific research documents, whether they are published or not. The documents may come from teaching and research institutions in France or abroad, or from public or private research centers.

L'archive ouverte pluridisciplinaire **HAL**, est destinée au dépôt et à la diffusion de documents scientifiques de niveau recherche, publiés ou non, émanant des établissements d'enseignement et de recherche français ou étrangers, des laboratoires publics ou privés.

# Design of a Very Low-power, Low-cost 60 GHz Receiver Front-End Implemented in 65 nm CMOS Technology

---

Michael Kraemer<sup>1,2</sup>, Daniela Dragomirescu<sup>1,2</sup>, Robert Plana<sup>1,2</sup>

<sup>1</sup> CNRS ; LAAS ; 7 avenue du colonel Roche, F-31077 Toulouse, France

<sup>2</sup> University of Toulouse ; UPS, INSA, INP, ISAE ; LAAS ; F-31077 Toulouse, France

*The research on the design of receiver front-ends for very high data-rate communication in the 60 GHz band in nanoscale CMOS technologies is going on for some time now. While a multitude of 60 GHz front-ends have been published in recent years, they are not consequently optimized for low power consumption. Thus, these front-ends dissipate too much power for battery-powered applications like handheld devices, mobile phones and wireless sensor networks.*

*This article describes the design of a direct conversion receiver front-end that addresses the issue of power consumption, while at the same time permitting low cost (due to area minimization by the use of spiral inductors). It is implemented in a 65 nm CMOS technology. The realized front-end achieves a record power consumption of only 43mW including low-noise amplifier (LNA), mixer, a voltage controlled oscillator (VCO), a local oscillator (LO) buffer and a baseband buffer (without this latter buffer the power consumption is even lower, only 29mW). Its pad-limited size is  $0.55 \times 1 \text{ mm}^2$ . At the same time, the front-end achieves state-of-the-art performance with respect to its other properties: Its maximum measured power conversion gain is 30dB, the RF and IF bandwidths are 56.5-61.5 GHz and 0-1.5 GHz, respectively, its simulated minimum noise figure is 8.4 dB and its measured  $IP_{-1dB}$  is -36 dBm.*

Keywords: to be added during submission

Corresponding author: Michael Kraemer; email: mkraemer@laas.fr; phone: +33 561 33 68 52

## I. INTRODUCTION

Historically, the design of radio front-ends and their building blocks in the 60 GHz band was based on compound semiconductors due to their very high unity gain frequencies. However, since technology scaling allowed the fabrication of CMOS devices with gate lengths of 130 nm or below, ever-increasing cutoff frequencies render mm-wave Radio-Frequency Integrated Circuits (RFICs) feasible. The use of CMOS technology is especially interesting for applications that demand low cost in mass production, co-integration of digital, mixed-signal and RF circuits to form a System on Chip (SoC) or, as shown in this paper, very low power consumption.

The very first 60 GHz receiver front-ends in CMOS technology by Razavi in 2005 [1] and Alldred *et al.* in 2006 [2] consisted only of an LNA, a mixer, and, in the latter case, associated LO and IF buffers. While the receiver front-end presented by Razavi exhibits a quite low power consumption, it does not include such power-hungry elements as the LO and IF buffers and the VCO [1].

More complete front-ends that also include a means to generate the LO signal were published subsequently. While [3-7] present the integration of an on-chip VCO together with a downconverter, a phase locked loop (PLL) was integrated in [8,9]. These realizations allow a more realistic comparison of the front-end power consumption, because the trade-off between the LO-power available to the mixer and the power consumption of VCO and mixer is done on-chip.

Note that also complete 60 GHz CMOS radios have been published and are even commercially available. However, they usually are not optimized with respect to power consumption. To the best of the author's knowledge, the transceiver by Marcu *et al.* [10] presents the lowest power consumption at this high level of integration for a 60 GHz radio.

The work presented in the following concentrates on the front-end, as it is the part mainly responsible for the circuit's power consumption [10]. A comparison to circuits exhibiting a comparable level of complexity, given in section V., shows that the results with respect to power consumption presented in this paper constitute record values. The achieved minimization is accomplished by a systematic design for low required LO-power (mixer), high efficiency (VCO) and low dissipated DC power (LNA). Furthermore, the use of a direct conversion architecture allows for a low device count and thus low complexity.

As second issue addressed by the design presented in this paper is the minimization of chip area: as many RFIC designers still follow the MMIC paradigm, mm-wave designs are often based on distributed elements for matching, which results in large circuit size and thus high fabrication cost. To minimize circuit area, however, spiral inductors shall be employed [11,12]. This paper shows that if the use of spiral inductors coincides with a low complexity direct conversion architecture, a record value for the receiver front-ends circuit size can be achieved.

The remainder of this article is organized as follows: First, section II gives an overview of the realized circuit and briefly discussed its basic building blocks and how they contribute to the front-ends low power consumption. Next, section III shows the fabricated circuit. In section IV, the obtained measurement results are discussed. These results are compared to the state-of-the-art in section V. Finally, a conclusion is drawn.

## II. Circuit Design

The receiver front-end presented in this paper consists of the in-phase branch of a direct conversion receiver. This circuit is part of a research effort aiming to integrate a complete 60 GHz I/Q transceiver front-end in 65 nm CMOS technology. While the final version of this

transceiver allows receiving a quadrature-modulated signal, the presented receiver front-end only allows the reception of simpler, less spectrally efficient modulations.

The block-diagram of the realized receiver front-end is illustrated in Fig. 1. Its off-chip interfaces consist of a single-ended 60 GHz RF input, a differential baseband (BB) output, and DC connections for the four bias voltages, the oscillator's control voltage, the 1 V power supply and ground.

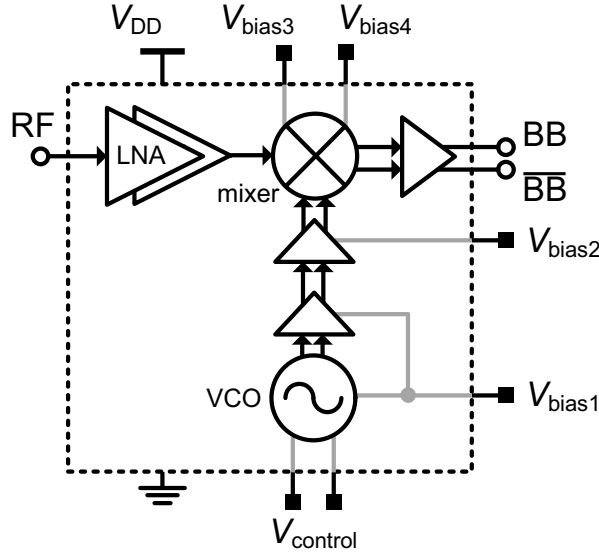

Fig. 1. Block diagram of the realized front-end with interfaces.

The following sub-sections discuss the key building blocks (LNA, down-mixer, VCO and baseband and LO buffers) that constitute the receiver front-end. Their circuit schematics are given together with some key figures describing their performance. The aspects of their design that concern the front-end's power consumption are also brought up.

Standalone – versions of these blocks have been separately fabricated and measured before receiver integration. The results obtained from their measurements are published in [13] for the LNA, [14] for the VCO and [15] for the down-mixer. To integrate these building blocks to form the front-end of figure Fig.1., the matching networks at their interfaces have been adapted accordingly. Furthermore, they are surrounded by grounded walls consisting of shunted metal layers that allow the isolation of adjacent building blocks.

### A) The Low Noise Amplifier

The requirements on the low noise amplifier are governed by the Friis equation. A simplified version, where  $NF_{LNA}$  is the noise figure of the LNA,  $NF_2$  the total noise figure of all subsequent circuit elements, and  $G_{LNA}$  the gain of the LNA, reads

$$NF_{tot} = NF_{LNA} + \frac{NF_2 - 1}{G_{LNA}} . \quad (1)$$

It illustrates that the receiver noise can be minimized only if the LNA has a low noise figure *and* high gain, the latter to decrease the influence of the subsequent stages on the noise performance. To achieve the optimization of these two parameters at the same time, a two-stage cascode LNA with the schematic given in Fig. 2. is employed. Its input stage is simultaneously noise and power matched by sizing the input transistor M1 and employing inductive source degeneration [13].

The cascode topology is preferred over a common source stage in order to increase reverse isolation, which is necessary to ensure unconditional stability and parasitic LO leakage from the mixer to the antenna.

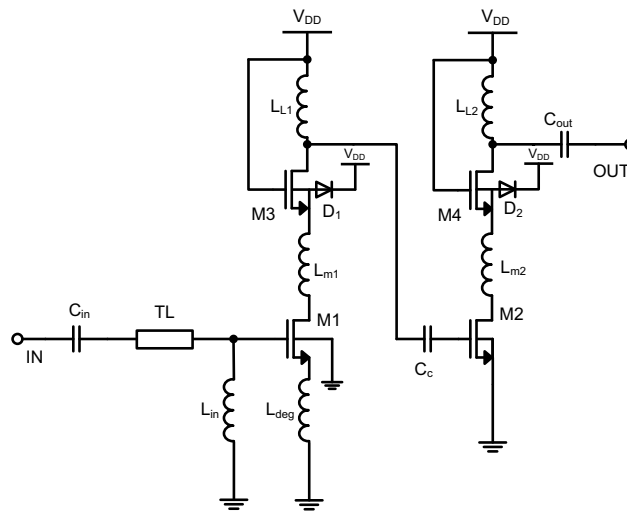

Fig. 2. Circuit schematic of the employed LNA [13]

While the LNA has a certain influence on the receiver linearity, it is the subsequent stages that are decisive in this regard. Thus, as power consumption is directly related to the linearity of the LNA (but does, in a first order consideration, not depend on the gain of the LNA), it can be minimized by sizing the transistors to yield minimum noise (first stage) or maximum power gain (second stage) for *low bias currents*.

Table 1. Performance summary of the LNA

Parameter	Value
Center frequency	58.3 GHz
Transducer power gain	16.8 dB
$IP_{-1dB}$	-25 dBm
$NF$ (simulated)	5.2 dB
$V_{DD}$	1V
$P_{DC}$	11 mW
Area (pad-limited)	$0.4 \times 0.4 \text{ mm}^2$

The measured performance of the standalone LNA is summarized in table 1. It stems from a redesigned version of the LNA presented in [13] which operates at a slightly higher center frequency. An in-detail discussion of the performance of the initial LNA is given in [13].

## B) The Down-conversion Mixer

When designing a low-power mixer circuit, two kinds of power consumption have to be taken into account: the dissipated DC power  $P_{DC}$  and the local oscillator power  $P_{LO}$  necessary for abrupt switching. Of these two powers, the latter one is by far the most expensive one in terms of overall receiver power consumption, as the on-chip oscillator used to generate the LO signal is usually of very low efficiency.

Besides power consumption, the Friis equation has to be respected, demanding high gain and low noise figure to minimize overall receiver performance. Furthermore, the down-mixer is the component limiting the receiver linearity, thus, it has to be optimized in this regard as well.

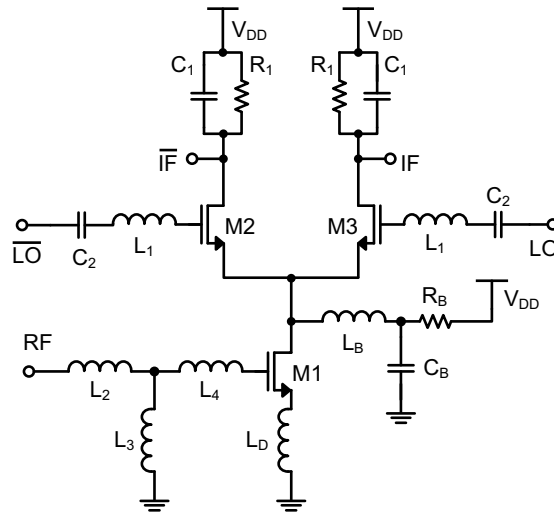

Fig. 3. Circuit schematic of the employed Down-conversion mixer.

To find an optimum compromise between all of these requirements, the single-balanced mixer shown in Fig. 3. is employed [15]. An active mixer has been chosen to obtain conversion *gain* and limit the required LO power. The input stage is simultaneously noise and power matched as in the case of the LNA.

The most important design technique ensuring the good performance of this mixer is current bleeding by the means of the inductor  $L_B$  and the resistor  $R_S$  [15]. As part of the bias current of M1 by-passes M2 and M3, the lower transistor M1 can provide high transconductance, while the switching pair is made up of small transistors that require only low LO power for fast switching. Furthermore, the bleeding inductor resonates the parasitic capacitances at the terminal common to all of the transistors, thus increasing conversion gain.

Note also the use of the capacitor  $C_1$  that short-circuits the resistive loads for the LO and RF signal. This allows for high LO and RF to baseband isolation and increases linearity and conversion gain.

The presented mixer exhibits an excellent compromise between all requirements over the whole unlicensed 60 GHz band. They are discussed in [15] and summarized in table 2. Note that these measurements result from a standalone version with baseband buffer (cf. Fig. 5a). The mixer's key performance, if a low-power receiver is desired, is the very low required LO power of only -5 dBm.

Table 2: Performance summary of the down-mixer

Parameter	Value
RF frequency range	54 - 65 GHz
IF frequency range	0 – 2 GHz
Max. power conversion gain	9.1 dB
$OP_{-1\text{dB}}$	-5 dBm
$NF$ (DSB, simulated)	9 dB
$V_{\text{DD}}$	1V
$P_{\text{LO}}$	-5 dBm
$P_{\text{DC}}$ (incl. buffer)	16.8 mW
Area (pad-limited)	$0.49 \times 0.52 \text{ mm}^2$

### C) The Voltage-Controlled Oscillator

Rather than minimizing the DC power consumption of the VCO, its efficiency, i.e.  $P_{\text{out}}/P_{\text{DC}}$ , has to be optimized to achieve a low-power receiver front-end. Otherwise, subsequent, power-hungry buffer stages become necessary.

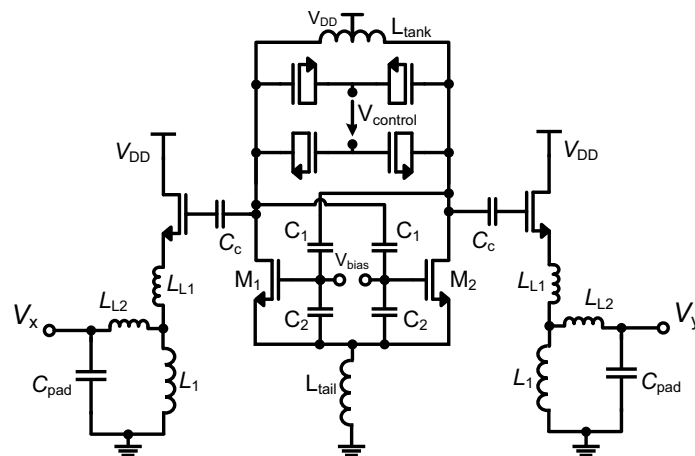

Fig. 4. Circuit schematic of the VCO with integrated common-drain buffer

The VCO used for this purpose is given in Fig. 4. [14]. Due to the use of a differential Colpitts architecture based on cross-coupled common-source transistors, the amplitude-limiting nonlinearity affects the behavior of the VCO only for quite high output powers. Thus, output power is higher than for other oscillator architectures at a given DC power consumption.

The VCO employs an octagonal 155pH inductance with differential Q of 19.1 at 60 GHz in the resonator. The frequency tuning is accomplished by differentially tuned accumulation-MOS varactors. A source-follower output buffer is attached to the oscillator core.

Further details on the design of the VCO are discussed together with the obtained results in [14]. Table 3 summarizes the performance of the VCO. Its record efficiency is one of the main reasons for the very low power consumption of the entire receiver, while the limited tuning range can be optimized by optimizing the (full-custom) varactor design.

Table 3: Performance summary of the VCO [14].

Parameter	Value
Frequency tuning range	57.58-60.8 GHz
Minimum Phase Noise	-90.3 dBc/Hz @ 1MHz
$V_{DD}$	1V
$P_{out}$	-0.9 dBm
$P_{DC}$ (incl. buffer)	16.5 mW
$P_{out} / P_{DC}$	4.93 %
Area (pad-limited)	$0.35 \times 0.59 \text{ mm}^2$

#### D) The LO and baseband buffers

In addition to the fundamental building blocks like LNA, mixer and oscillator, buffer amplifiers are employed in the receiver front-end. Their schematics are given in Figures 5a and 5b.

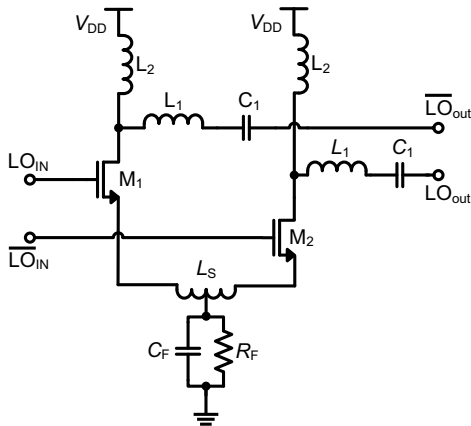

Fig. 5a. Second LO buffer

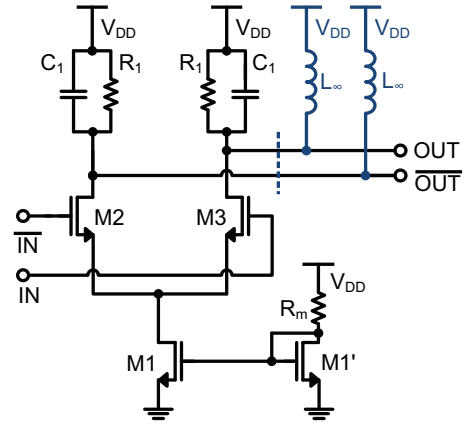

Fig. 5b. Baseband output buffer

The LO buffer is used to further increase the LO power level at the input of the down-mixer and to increase common-mode rejection in the LO signal path by means of the tail impedance consisting of  $C_F$  and  $R_F$ . It is based on a differential common-source amplifier. Due to the low LO power requirements of the mixer this buffer is not essential, but is integrated in view of a later quadrature receiver. In the receiver at hand it is biased at very low bias current.



The baseband buffer of Fig. 5b is added to the baseband output of the mixer. It is necessary to drive the differential  $100\ \Omega$  load, which is encountered if characterizing the receiver front-end using a measurement setup with instruments that exhibit single-ended  $50\ \Omega$  input impedances. It is based on a current-mirror biased differential pair. The load impedances consist of an on-chip R-C load (which filters LO and RF signals) and a large off-chip inductance that allows biasing the buffer transistors without suffering from the large voltage drop that would occur if the bias current would pass by the resistors.

The baseband buffer consumes 14 mW due to the large current required by the low-impedance load. In a more complete integrated receiver circuit, it shall be replaced by a variable gain amplifier (VGA) with high impedance load, achieving much lower power consumption ( $<5\text{mA}$ ) while exhibiting huge, variable gain ( $>50\ \text{dB}$ ). Thus, the front-end's power consumption can be considered 14 mW lower, if it is integrated with the baseband circuit.

### III. THE FABRICATED FRON-END CIRCUIT

Fig. 6. shows the die photograph of the fabricated receiver frontend. Its very small size of  $0.550\ \text{mm}^2$  is essentially pad-limited: the aligned circuit blocks without pads are only about  $200\ \mu\text{m}$  wide. This is the result of using a total of 17 compact spiral inductors for matching.

The number of pads can further be reduced because multiple VDD and ground connections are provided (see the respective symbols in Fig. 6.). These redundant connections are not essential for the operation of the receiver due to its low supply current (about 43 mA). Furthermore, the bias voltages could be derived from  $V_{\text{DD}}$  in a redesigned version, allowing to remove four more pads. The part of the circuit shown at the right in Fig. 6., which consists of the differentially implemented parts, is very symmetric to reduce mismatch and improve isolation.

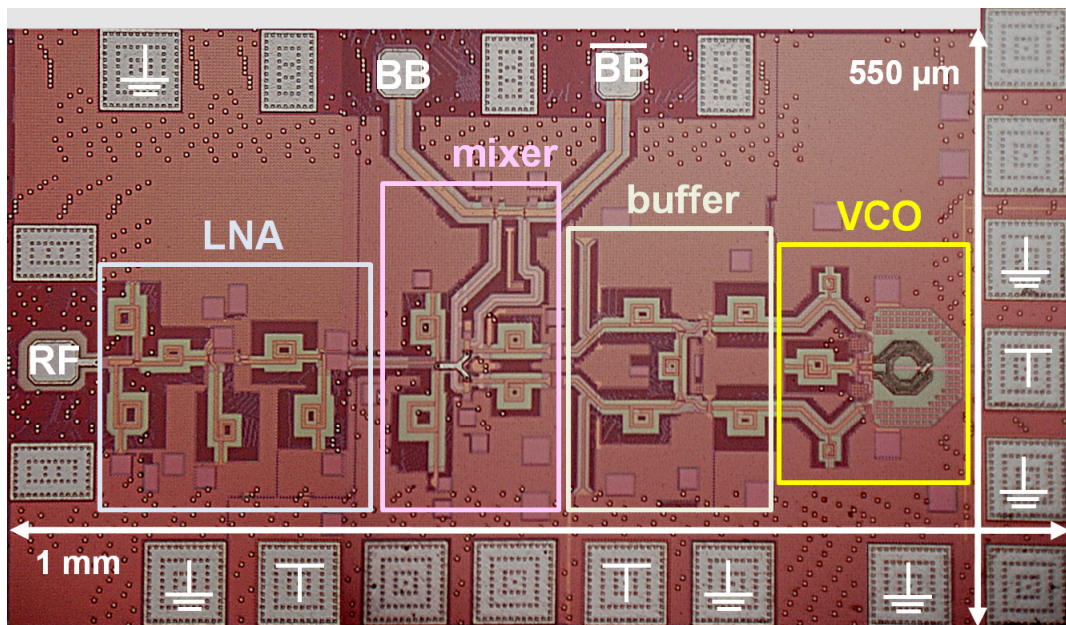

Fig. 6. Microphotograph of the fabricated CMOS receiver front-end

## IV. MEASUREMENT RESULTS

The receiver front-end was characterized on-wafer using a 67GHz single-ended 100  $\mu\text{m}$  G-S-G Picoprobe to provide the RF signal and a differential G-S-G-S-G probe of the same type to measure the baseband output. The DC voltages were connected using two eyepass six-finger probes. The measurements were done using either an Anritsu MS4647A 70GHz VNA to obtain the return loss. In this case, one of the differential baseband outputs was matched to 50 $\Omega$  by a precision load. Or, for conversion measurements, an Agilent E8257D 67GHz synthesizer served as signal source and a LeCroy SDA813Zi 13GHz real time oscilloscope with spectrum analyzer functionality was connected to the circuit's differential baseband output. The loss due to cable and probes is de-embedded and 3 dB is added to the output power in case of single ended measurements.

### A) Power Consumption

The receiver front-end is biased at the optimum current densities of the circuit components by applying bias voltages of  $V_{\text{bias1}} = 460\text{mV}$ ,  $V_{\text{bias2}} = 390\text{mV}$ ,  $V_{\text{bias3}} = 510\text{mV}$  and  $V_{\text{bias4}} = 540\text{mV}$ . It draws about 43mA from a 1V supply, thus consuming  $P_{\text{DC}} = 43\text{mW}$ . This power consumption can be reduced by the amount contributed by the baseband buffers (i.e.  $\approx 14\text{mA}$ , cf. section 4.4) in an integrated version, because the BB output usually does not have to drive two 50 $\Omega$  loads but a variable gain amplifier with high impedance inputs. Thus, VCO, LO buffers, down-mixer and LNA together consume only 29mW.

### B) In- and Output Return Loss

The return loss at the RF input and the baseband output of the receiver front-end were measured at the above mentioned bias point with a control voltage of  $V_{\text{control}} = 0\text{ V}$ , corresponding to a LO frequency of about  $f_0 = 57.5\text{GHz}$ . However, the oscillation frequency does not have any influence on the return loss, as both input and output of the receiver are very well isolated from the LO.

The left part of figure 7 shows the measured excellent, broadband input match which lies below -10 dB from 53.1GHz up to 66.0 GHz. A minimum return loss of -42.7 dB is achieved at 58.9 GHz. The measured return loss at the baseband output of the receiver front-end, shown in the right part of figure 7, is about -17.4 dB within the entire required baseband bandwidth of about 1 GHz, and stays below -10 dB up to 12.5 GHz.

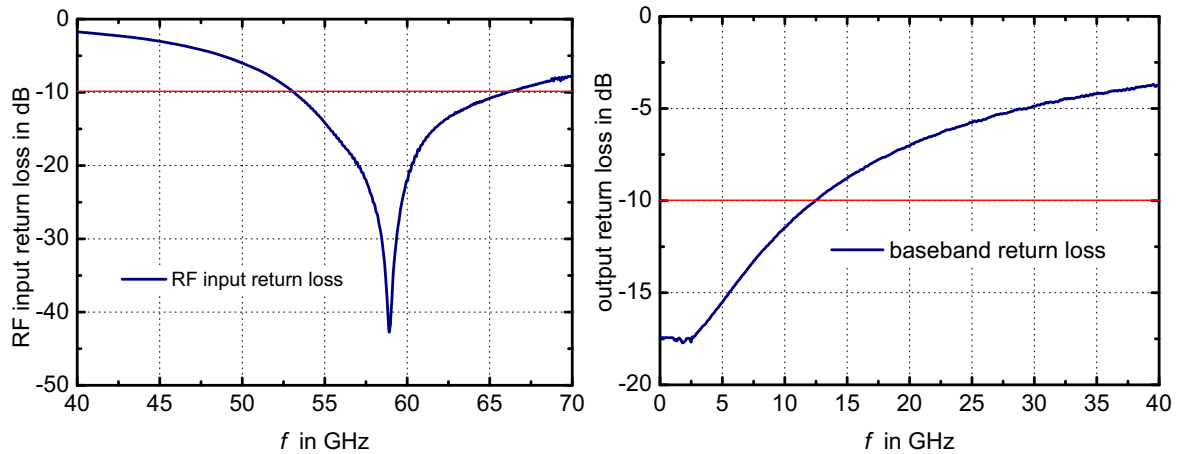

Fig. 7. Measured in- and output return loss of the receiver front-end

### C) Frequency Tuning Range

As for the VCO presented above, the frequency tuning range of the receiver is about 3 GHz. However, the absolute oscillation frequencies have slightly shifted for the complete receiver. They lie between 57.0GHz and 60.0GHz for a control voltage between 0.15V and -3V. This can be explained by the different loads connected to the VCO and the fact that automatic dummy insertion was done differently between the fabrication runs of the standalone VCO and the receiver front-end.

### D) Conversion Gain

To measure the receiver's conversion gain, a low-power sinusoidal signal is injected at the RF port of the receiver front-end. In the lower sideband (LSB), this signal lies  $f_{IF}$  below the carrier frequency, in the upper sideband (USB) this signal is  $f_{IF}$  above  $f_{LO}$ . The ratio between the received power at the differential baseband output and the injected signal power is denoted as power conversion gain  $G_C$  in the following. (Note that due to the use of very high impedances at the baseband output, receivers in literature often report the voltage conversion gain [1], which in these cases is considerably higher than the power conversion gain).

Fig. 8. (left) plots the conversion gain in the LSB and USB for baseband frequencies of 1GHz and 2 GHz. A maximum power conversion gain of 29.5 dB is achieved for a baseband frequency of  $f_{IF}=1$  GHz. In agreement with the input return loss and the characteristic of the LNA, the LO frequency for which both sidebands have the same conversion gain is about 58.75 GHz. The 3 dB RF bandwidth of the receiver, which is limited by the response of the LNA, reaches from about 56.5GHz to about 61.5 GHz, thus spanning 5GHz in the lower part of the unlicensed 60GHz band. The LO frequency range considered is limited by the oscillator's tuning range.

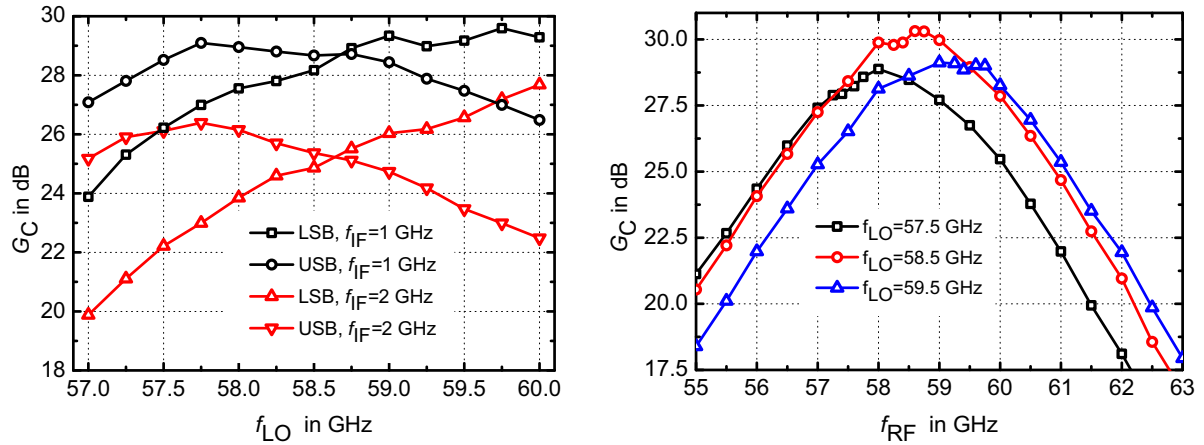

Fig. 8. Measured conversion gain  $G_C$  of the receiver front-end

Fig. 8 (right) plots the conversion gain versus RF input frequency for different LO frequencies. It illustrates that within the bandwidth of 1.88GHz around the carrier, which is required by the different standards, quite high values between 26 dB and 30 dB are achieved at all possible LO frequencies. For the central LO frequency of  $f_{LO}=58.5$  GHz, the one-sided 3 dB baseband bandwidth is measured to be about 1.5 GHz, corresponding to a channel bandwidth of 3GHz around the carrier. The receiver's bandwidth is not limited by the baseband circuitry or the mixer, but rather by the characteristics of the LNA, which results in the fact that input signals above and below the center frequency of 58.5GHz experience less gain.

### E) Output Waveforms

To analyze the balance of the differential signal at the baseband output of the receiver, the voltage waveforms were measured for different frequencies and input powers. Fig. 9. shows this signal at both baseband outputs when the frequency difference is 1 GHz. Even at this relatively high frequency, the phase shift of  $180^\circ$  is well maintained, while variations occur due to the phase variations of the unlocked VCO. For lower baseband frequencies, the voltage waveforms are even better balanced.

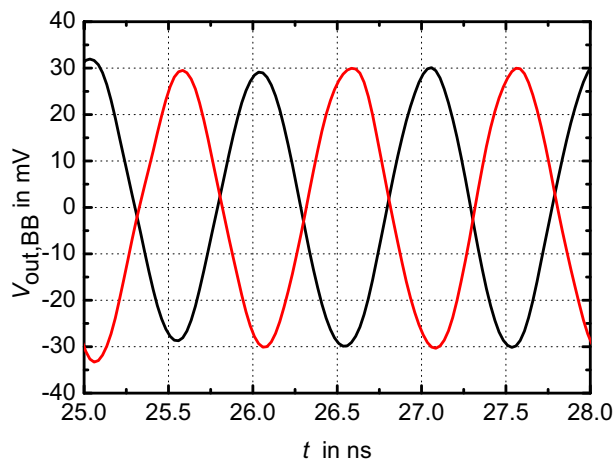

Fig. 9. Measured baseband output voltages for  $f_{LO}=58$  GHz,  $f_{RF}=59$  GHz and  $P_{RF}=-45$ dBm

## F) Linearity and Noise

The linearity of the receiver front-end is characterized by its 1 dB compression point  $P_{-1dB}$ . Fig. 10. plots power conversion gain and output power versus input power to obtain its value: it shows that the receiver achieves an output-referred compression point  $OP_{-1dB} = -11$  dBm, which corresponds to an input-referred compression point of  $IP_{-1dB} = -36$  dBm. This quite low value at the input of the receiver results from the high conversion gain and the moderate linearity of the output buffer. However, as both the received in-band power and the interference power level at the receiver input are expected to lie well below this value, this compression point is sufficient for a 60GHz receiver and helps to keep power consumption low.

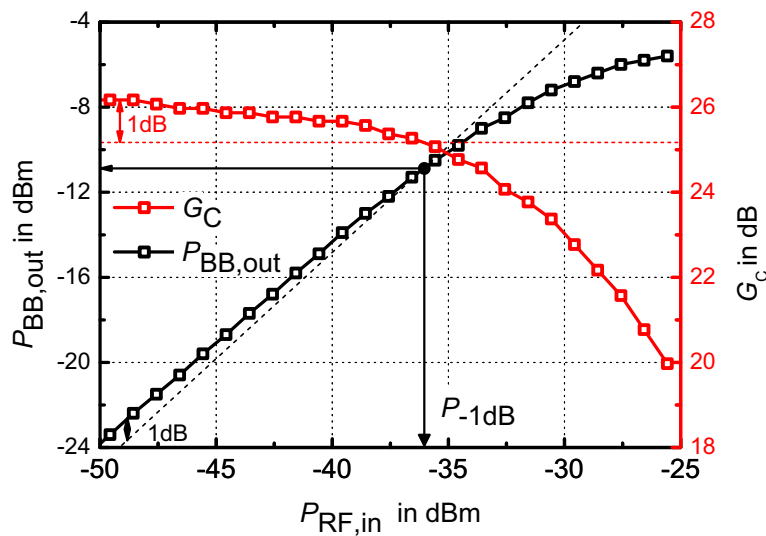

Fig. 10. Measured output versus input power of the receiver front-end

As an appropriate noise source working in the 60GHz band was not available at the time of the measurement of the receiver, its noise figure is predicted by a SPECTRE RF PSS/PSP simulation. The noise figure stays close to 9 dB within the entire communication band, with a minimum value of 8.4 dB. As the PSP simulation slightly underestimates the conversion gain (about 25 dB are simulated at 1GHz from the carrier), the actual measured noise figure is expected to be below 9 dB.

## V. State-of-the-art Comparison

Table 1 compares the presented receiver front-end to the state of the art. It contains published front-ends of comparable levels of complexity. The third column shows which components, besides LNA and mixer(s), are included in each circuit.

The front-ends achieving the best performance for each column are highlighted. The comparison shows that the first strength of the proposed implementation is its very low power consumption of only 43mW (which is even lower, i.e. 29 mW, without the baseband buffers). This value is lower than that of other receiver front-ends of comparable complexity. The

second strength is the very small size of the presented implementation, which originates from the use of spiral inductors and the realization in 65nm technology. Furthermore, the achieved conversion gain of 30 dB compares very favorable to the state of the art. As the noise figure of the receiver could not be measured, a final statement is not possible with respect to this characteristic. However, the simulated value indicates that the circuit also achieves good noise performance.

Regarding the realized bandwidth, the table shows that most of the receiver front-ends only cover parts of the unlicensed 60GHz band. The proposed realization is no exception. With 5GHz it exhibits a typical performance in this regard. The weak point with respect to the state of the art of the presented front-end is its linearity, quantified by an input-referred compression point of only -36 dBm. This low value can be explained by the front-end's low supply voltage of 1.0V and its high conversion gain, which results in a saturation of the output stages. However, for the application of the front-end this is not critical, as the received input power is not expected to ever attain this compression point. An important point in low-power 60 GHz receiver design is to correctly predict the expected maximum input signal (usually originating from interference) and adjust the required linearity accordingly, as it is directly related to the achievable minimum power consumption.

Table 4. CMOS receiver front-ends of comparable complexity found in literature

Ref.	Tech. [nm]	Consists of LNA, mixer &	RF [GHz]	IF [GHz]	NF(DSB) [dB]	G <sub>C</sub> [dB]	IP <sub>-1dB</sub> [dBm]	P <sub>DC</sub> [mW]	Area [mm <sup>2</sup> ]
S. Emami, 2007 [1]	130	IF amp., VCO, doubler	57-63	2.0	10.4	11.8	-15.8	76.8	3.8
Sanduleanu, 2007 [2]	90	VCO	59-61	0	9.5	23	N.A.	54	0.86
T. Mitomo, 2008 [3]	90	BB buff., PLL, antenna	61.3-63.4	0.1	8.4	22.5	N.A.	144	2.64
K.H. Chen, 2008 [4]	90	PLL	61.4-63	1	5.64	25.2	-16	132	1
J. Lee, 2009 [5]	90	IF buff., VCO, OOK demod.	60	10	7	25	-26	103	0.68
S. Bozzola, 2009 [6]	65	BB & LO buff., VCO	62-67	20	9	281	-26	80	0.52
F. Vecchi, 2010 [7]	65	BB & LO buff., VCO	55-68	20	5.6	35.5	-39	75	2.5
<b>proposed front-end</b>	<b>65</b>	<b>BB &amp; LO buff., VCO</b>	<b>56.5-61.5</b>	<b>0-1.5</b>	<b>8.45</b>	<b>30</b>	<b>-36</b>	<b>43</b>	<b>0.55</b>

## VI. CONCLUSION

This paper presented the design and implementation of a low-power low-cost receiver front-end for the unlicensed 60 GHz band in 65 nm CMOS technology. With its record-low power consumption of only 43 mW (29 mW without the baseband buffers that are used to drive 50  $\Omega$  loads and are not necessary in a high-impedance integrated baseband), its record-small circuit size of 0.55 mm<sup>2</sup>, its RF bandwidth spanning from 56.5 to 61.5 GHz and its very high conversion gain of 30 dB it compares very favorable to the state-of-the art.

This paper shows that to achieve this kind of results, the design of the 60 GHz building blocks must be optimized with respect to efficiency and both DC *and* LO power consumption (the latter in the case of the mixers). Furthermore, the interfaces between the blocks need not only to be power-matched to each other, but also the power *levels* at these interfaces need to be accounted for to optimize overall system performance. Furthermore, the use of spiral inductors, rather than distributed elements, is essential for achieving small circuit size.

## ACKNOWLEDGEMENT

This work has been supported by the French National Research Agency (ANR) in the framework of the program Recherche Technologique Nano-INNOV/RT NANOCOMM project NANR-09-NIRT-004 and by the european Medea+ project QStream.

## REFERENCES

- [1] B. Razavi. "A 60-GHz CMOS receiver front-end." IEEE Journal of Solid-State Circuits, 41(1):17–22, January 2006.
- [2] D. Alldred, B. Cousins, and S.P. Voinigescu. "A 1.2V, 60-GHz radio receiver with on-chip transformers and inductors in 90-nm CMOS." In IEEE Compound Semiconductor Integrated Circuit Symposium, 2006, pages 51–54, November 2006.
- [3] Sohrab Emami, Chinh H. Doan, Ali M. Niknejad, and Robert W. Brodersen. "A highly integrated 60GHz CMOS front-end receiver." In ISSCC 2007, pages 190–191, 11-15 Feb. 2007.
- [4] M.A.T. Sanduleanu and J.R. Long. "CMOS integrated transceivers for 60GHz UWB communication. In IEEE International Conference on Ultra-Wideband, 2007", pages 508 – 513, 24-26 2007.
- [5] Jri Lee, Yenlin Huang, Yentso Chen, Hsinchia Lu, and Chiajung Chang. "A low-power fully integrated 60GHz transceiver system with OOK modulation and on-board antenna assembly". In ISSCC 2009, pages 316–317,317a, Feb. 2009.

- [6] S. Bozzola, D. Guermandi, F. Vecchi, M. Repposi, M. Pozzoni, A. Mazzanti, and F. Svelto. "A sliding IF receiver for mm-wave WLANs in 65nm CMOS. IEEE Custom Integrated Circuits Conference, 2009., pages 669–672, September 2009.
- [7] F. Vecchi, S. Bozzola, M. Pozzoni, D. Guermandi, E. Temporiti, M. Repposi, U. Decanis, A. Mazzanti, and F. Svelto. "A wideband mm-wave CMOS receiver for Gb/s communications employing interstage coupled resonators." *ISSCC 2010*, pages 220 –221, 7-11 2010.
- [8] T. Mitomo, R. Fujimoto, N. Ono, R. Tachibana, H. Hoshino, Y. Yoshihara, Y. Tsutsumi, and I. Seto. "A 60-GHz CMOS receiver front-end with frequency synthesizer." *IEEE Journal of Solid-State Circuits*, 43(4):1030–1037, April 2008.
- [9] Ke-Hou Chen, Chihun Lee, and Shen-Iuan Liu. "A dual-band 61.4-63GHz/75.5-77.5GHz CMOS receiver in a 90nm technology." In *IEEE Symposium on VLSI Circuits*, 2008, pages 160–161, June 2008.
- [10] C. Marcu, D. Chowdhury, C. Thakkar, Jung-Dong Park, Ling-Kai Kong, M. Tabesh, Yanjie Wang, B. Afshar, A. Gupta, A. Arbabian, S. Gambini, R. Zamani, E. Alon, and A.M. Niknejad. "A 90 nm CMOS low-power 60 GHz transceiver with integrated baseband circuitry". *IEEE Journal of Solid-State Circuits*, 44(12):3434 –3447, December 2009.
- [11] T.O. Dickson, M.-A. LaCroix, S. Boret, D. Gloria, R. Beerkens, and S.P. Voinigescu. "30-100-GHz inductors and transformers for millimeter-wave (Bi)CMOS integrated circuits." *IEEE Transactions on Microwave Theories and Techniques*, 53(1):123–133, January 2005.
- [12] Michael Kraemer, Daniela Dragomirescu, and Robert Plana. "Accurate electromagnetic simulation and measurement of millimeter-wave inductors in bulk CMOS technology." *10th Topical Meeting on Silicon Monolithic Integrated Circuits in RF Systems*, January 2010.
- [13] Michael Kraemer, Daniela Dragomirescu, and Robert Plana. "A low-power high-gain LNA for the 60GHz band in a 65 nm CMOS technology." In *APMC 2009*, 2009.
- [14] Michael Kraemer, Daniela Dragomirescu, and Robert Plana. A high efficiency differential 60 GHz VCO in a 65 nm CMOS technology for WSN applications. *IEEE Microwave and Wireless Components Letters*, accepted for publication 2010.
- [15] Michael Kraemer, Mariano Ercoli, Daniela Dragomirescu, and Robert Plana. "A wideband single-balanced down-mixer for the 60 GHz band in 65 nm CMOS". In *APMC 2010*, 2010.



## Bibliographies



**Michael Kraemer** was born in Bad Mergentheim, Germany, in 1980. He received the Dipl.-Ing. (BA) degree from BA Mosbach, Germany, in 2003 and the Dipl.-Ing. degree from the University of Stuttgart, Germany, in 2007, both in electrical engineering and is currently working toward his Ph.D. degree at LAAS-CNRS in Toulouse, France.

During his studies, he stayed one year at University of Massachusetts, Amherst, USA, and did internships at ebm-papst GmbH, DaimlerChrysler AG and Robert Bosch GmbH. His research interests include the design and modeling of millimeter wave circuits.

Mr. Kraemer is a Fulbright fellow and the recipient of the 2007 VDE-award at the University of Stuttgart.



**Daniela Dragomirescu** was born in Bucharest, Romania in 1972. She received the Electronics and Telecommunication engineering degree from Bucharest Polytechnic University, Romania in 1996 and her Ph.D. degree from the National Institute of Applied Sciences, Toulouse, France.

She is an Associate Professor at National Institute of Applied Sciences, Toulouse and a researcher at Laboratory for Analysis and Systems' Architecture (LAAS-CNRS). Her main research interests are in Wireless Sensor Networks, system architecture and modeling and digital and RF circuit design.



**Robert Plana** Robert Plana was born on March 1964 In Toulouse. He obtained his PhD in 1993 at LAAS-CNRS and Paul Sabatier University on the Noise modelling and characterization of Advanced Microwave devices (HEMT, PHEMT and HBT)

that includes the reliability. In 1993, as associate professor at LAAS-CNRS, he has started a new research area concerning the investigation of millimeter-wave capabilities of Silicon based technologies. More precisely, he has focussed on the microwave and millimeter-wave properties of SiGe devices and their capabilities for low noise circuits. In 1995, he has started a new project concerning the improvement of the passives on silicon through the use of MEMS technologies. In 1999, he has been involved with SiGe Semi-conductor in Ottawa where he was working on the low power and low noise integrated circuits for RF applications. In the same year, he has received a special award from CNRS for his works on Silicon based technologies for millimeter-wave communications. In 2000, he has been professor at Paul Sabatier University and Institut Universitaire de France and he has started a research team at LAAS-CNRS in the field of Micro and Nanosystem for RF and millimeter-wave communications. Its main interests are on the technology, design, modelling, test, characterization and reliability of RF MEMS for low noise and high power millimeter-wave applications and the development of the MEMS IC concept for smart microsystems. He has built a network of excellence in Europe in this field “AMICOM” regrouping 25 research groups. He has authored and co-authored more than 300 international journals and conferences. In 2004, he has been appointed as Deputy Director of the Information and Communication Department at the CNRS Headquarter. From January 2005 to January 2006, he has been appointed director of the Information and Communication Department at CNRS. Since 2006, he is heading a research group at LAAS-CNRS in the field of Micro and Nanosystems for wireless communications. From November 2007 to November 2009, he joined the “French research Agency” where he is the project officer of the National Nanotechnology Initiative. Since November 2009, he is appointed as head of the department “Physic, Mathematics, Nanosciences & Nanotechnology, Information and Communication Technology” at the Ministry of research in charge of defining the French strategic for research and innovation.

## List of figures and tables

Fig. 1. Block diagram of the realized front-end with interfaces.

Fig. 2. Circuit schematic of the employed LNA

Fig. 3. Circuit schematic of the employed Down-conversion mixer

Fig. 4. Circuit schematic of the VCO with integrated common-drain buffer

Fig. 5a. Second LO buffer

Fig. 5b. Baseband output buffer

Fig. 6. Microphotograph of the fabricated CMOS receiver front-end

Fig. 7. Measured in- and output return loss of the receiver front-end

Fig. 8. Measured conversion gain  $G_C$  of the receiver front-end

Fig. 9. Measured baseband output voltages for  $f_{LO}=58$  GHz,  $f_{RF}=59$  GHz and  $P_{RF}=-45$ dBm

Fig. 10. Measured output versus input power of the receiver front-end

Table 1. Performance summary of the LNA

Table 2: Performance summary of the down-mixer

Table 3: Performance summary of the VCO

Table 4. CMOS receiver front-ends of comparable complexity found in literature