



HAL
open science

Improvement of the NO_x selectivity for a planar YSZ sensor

Jing Gao, Jean-Paul Viricelle, Christophe Pijolat, Philippe Breuil, Philippe Vernoux, Antoinette Boreave, Anne Giroir-Fendler

► **To cite this version:**

Jing Gao, Jean-Paul Viricelle, Christophe Pijolat, Philippe Breuil, Philippe Vernoux, et al.. Improvement of the NO_x selectivity for a planar YSZ sensor. *Sensors and Actuators B: Chemical*, 2011, 154 (2), pp.106-110. 10.1016/j.snb.2010.01.033 . hal-00590817

HAL Id: hal-00590817

<https://hal.science/hal-00590817>

Submitted on 5 May 2011

HAL is a multi-disciplinary open access archive for the deposit and dissemination of scientific research documents, whether they are published or not. The documents may come from teaching and research institutions in France or abroad, or from public or private research centers.

L'archive ouverte pluridisciplinaire **HAL**, est destinée au dépôt et à la diffusion de documents scientifiques de niveau recherche, publiés ou non, émanant des établissements d'enseignement et de recherche français ou étrangers, des laboratoires publics ou privés.

Improvement of the NO_x selectivity for a planar YSZ sensor

JING GAO⁽¹⁾, JEAN-PAUL VIRICELLE^{(1)*}, CHRISTOPHE PIJOLAT⁽¹⁾, PHILIPPE BREUIL⁽¹⁾, PHILIPPE VERNOUX⁽²⁾, ANTOINETTE BOREAVE⁽²⁾, ANNE GIROIR-FENDLER⁽²⁾

⁽¹⁾ *Ecole Nationale Supérieure des Mines de Saint Etienne, Centre SPIN ; Département MICC ; LPMG -UMR CNRS 5148, 158 Cours Fauriel - 42023 Saint-Étienne Cedex 2, France*

⁽²⁾ *IRCELYON, Université Lyon 1, CNRS, UMR 5256, 2 Avenue Albert Einstein, 69626 Villeurbanne Cedex, France*

Abstract

In recent years planar yttria-stabilized zirconia (YSZ) based electrochemical gas sensors for automotive exhaust applications have become a major source of interest. The present work aims to develop a sensor for industrialisation. For this reason planar YSZ-based electrochemical sensors using two metallic electrodes (platinum and gold) were fabricated using screen-printing technology and tested in a laboratory test bench for different concentrations of pollutant gas such as CO, NO, NO₂ and hydrocarbons in oxygen rich atmosphere. It was furthermore shown that the selectivity towards NO_x could be highly reinforced by depositing a catalytic filter consisting of 1.7–4.5 wt.% Pt dispersed on alumina directly on the sensing elements. This filter was characterized by the use of SEM, TPD and XRD.

Keywords:

Electrochemical gas sensor; NO_x sensor; Catalytic filter; NO_x selectivity; Automotive exhaust

1. Introduction

Since many years researchers have been working on the development of a reliable electrochemical gas sensor for automotive exhausts application to control the emission of carbon monoxide (CO), nitrogen oxides (NO_x), especially nitrogen monoxide (NO) and nitrogen dioxide (NO₂), and hydrocarbons (CH_x). Potentiometric gas sensors with a solid electrolyte based on zirconia stabilized by yttria or scandia, YSZ or SSZ, respectively, or on β-alumina are considered as the most successful ones [1], [2], [3], and [4]. The sensing principle of this sensor type is based on the development of a mixed-potential as studied by many research groups [5], [6], and [7]. Furthermore a model of the detection mechanism has been proposed by our group which explains the responses to oxygen [8] and hydrocarbons [9]. However, one of the major problems accounted with these sensors, as for other types, is the selectivity [10] and [11]. As the European Commission has focused in their latest emission requirements proposals (Euro V and Euro VI) specifically on the reduction of the NO_x emission, one of the major challenges today is the enhancement of the NO_x selectivity [12], [13], [14] and [15].

In order to meet this requirement, many approaches have been made. For instance, Miura *et al.* have proposed a complex impedance-based YSZ sensor using ZnCr₂O₄ sensing electrode to reduce interfering signals from other combustible gases and oxygen deviation disturbance [16]. In the potentiometric mode selectivity towards a gas species can be modified by changing the

* Auteur à qui la correspondance devait être adressée : viricelle@emse.fr

sensing electrode. A good overview of electrode materials tested in the past was given in the review of Fergus [17]. Otherwise, it is possible to enhance the NO_x selectivity by using an oxidation-catalyst electrode to oxide interferences and hence decrease cross-sensitivity from reducing gases [17]. The same effect can be reached if a catalyst is deposited before the gas mixture arrives to the sensing elements [18] and [19]. In the present work, it was opted to develop a planar potentiometric YSZ sensor with a catalytic filter directly deposited on the sensitive part of the sensor in order to meet the industrial demand of a robust, reliable NO_x sensor with a simple configuration.

II. Experimental

For the fabrication of planar potentiometric sensors, screen-printing technology was used to deposit an YSZ solid electrolyte and two metallic electrodes (commercial pastes), one in gold and one in platinum, on an alumina sheet (Figure 1). Gold paste was equally used to establish the connection between the sensor and the acquisition system. On the back a platinum heating element is printed to ensure the control of the temperature.

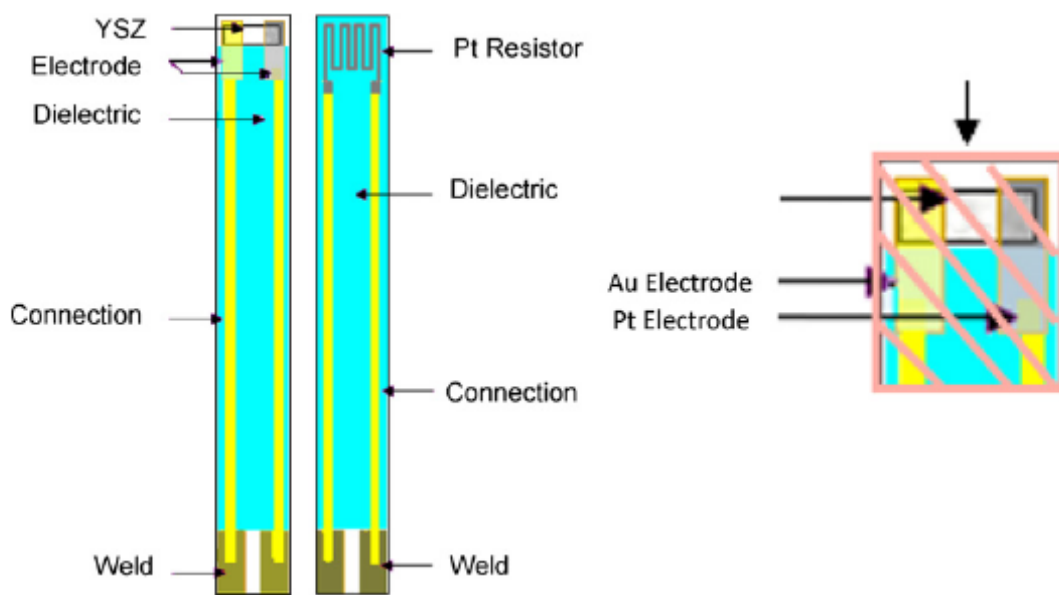

Figure 1: Schematic of the sensor.

In order to produce sensors with enhanced selectivity towards NO_x a catalytic filter layer (40–80 μm) was deposited over the sensing elements with a subsequent calcination process at 850 °C for an hour. After series of tests, two catalytic filters consisting of 1.7 wt.% and 4.5 wt.% platinum dispersed in alumina (referred as Pt1.7 and Pt.4.5, respectively, in the following), were retained for further investigation.

The fabricated sensors were tested in a conventional flow apparatus (Figure 2). The gas flow in the sensing chamber consisted basically of a synthetic gas containing 12 vol.% O₂, 2 vol.% H₂O and nitrogen balance. Pollutant gases such as CO, NO and NO₂ were added to the base gas in a concentration range of 50–300 ppm. The total flow rate amounted to 30 l/h. While the entering gas mixture had ambient temperature, the sensors were heated to 400–550 °C in order to establish an optimal working temperature. The measured electromotive force (denoted as EMF) was the potential difference between the gold and the platinum electrode ($V_{Pt} - V_{Au}$).

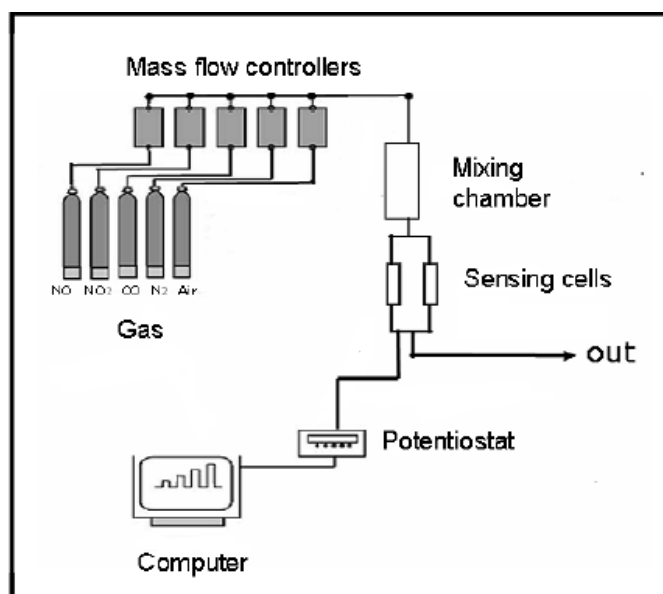

Figure 2: Test bench.

By applying X-ray diffraction (D-5000, Siemens) and scanning electron microscopy (Hitachi S-800) technologies the crystallographic structure and the surface morphology of the deposited catalytic filter layer were characterized.

The adsorption–desorption behaviour of NO_2 was investigated by means of TPD. In a U-shaped quartz tube, 0.1 g of the Pt1.7 powder, used to fabricate the catalytic layer, was placed and heated to 450 °C. The sample was then exposed to a gas mixture consisting of 300 ppm NO_2 , 3.5% oxygen and helium balance for 12 h successively. The sample was then cooled down to room temperature in the same atmosphere and treated 10 min with pure helium. For the desorption, the sample was heated under helium up to 700 °C with a heating rate of 15 °C/min and a helium flow rate of 3 l/h. The NO , O_2 desorption were followed by a mass spectrometer (VGgas Smart-IQ+).

Furthermore, in order to determine the minimum temperature which is necessary to oxidize light hydrocarbons, a catalytic flow experiment has been carried out. 0.2 g of Pt4.5 was introduced in a U-shaped quartz reactor. At a flow rate of 10 l/h, the conversions into CO_2 and H_2O of various hydrocarbons (methane, propane and propene), either pure or mixed together, were determined by analysing the gas mixture with a microgas chromatograph (Varian, CP2003) and a near infrared spectrometer (EMERSON).

III. Results and discussion

III.1. Sensing characteristics of the sensor without a catalytic layer

In the absence of a catalytic filter layer and at 450 °C (temperature at which the sensitivity to NO_x reached its maximum), a positive response in regard to the baseline recorded in 12% oxygen with nitrogen balance was obtained for reducing gases such as CO and NO (Figure 3), whereas the oxidizing gas NO_2 responded negatively. This was due to the difference in the redox potential of the gases and the different electrocatalytic properties of the electrodes. Similar sensing behaviour has been reported already in the literature [20]. Remarkable is the fact that NO_2 has a much higher sensitivity than NO.

III.2. XRD and SEM characterisation of the filter layer

In order to characterize the deposited catalytic filter layer Pt1.7 X-ray diffraction analysis (XRD) and scanning electron microscopy (SEM) were used. By applying XRD technology only alumina (α - and γ -phase) and platinum crystallographic phases were detected which indicated that there was no major pollution on the catalytic layer.

SEM pictures of secondary electrons and backscattered electrons (Figure 4) showed that the surface of the catalytic layer was non-fissured. The image of backscattered electrons revealed

that the platinum particles are not totally homogeneously dispersed on the surface of the support with alumina areas of about $5 \mu\text{m}^2$ not covered with platinum. This is probably due to the calcination step during the deposition process which leads to Pt particles sintering.

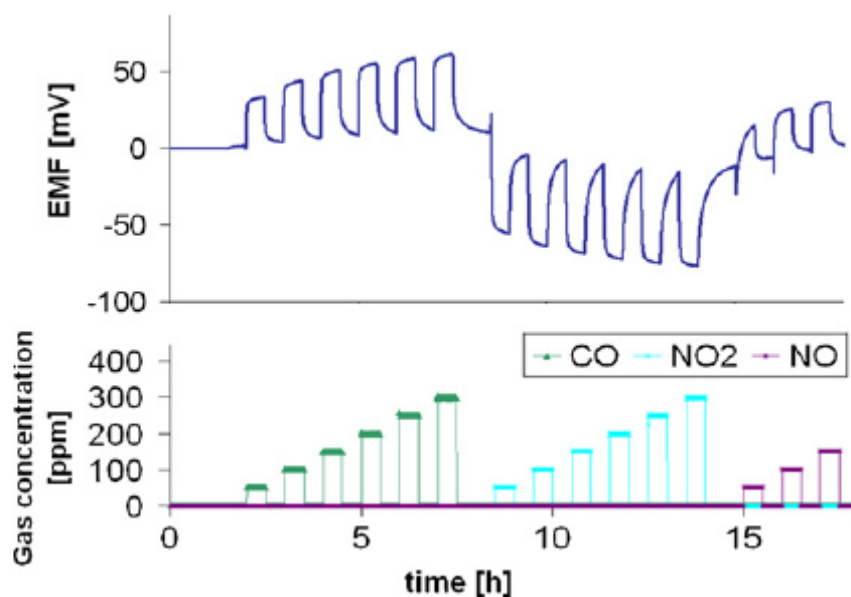

Figure 3: Sensor response to CO, NO and NO₂ at 450 °C (base gas: 12 vol.% O₂, 2 vol.% H₂O and N₂ balance).

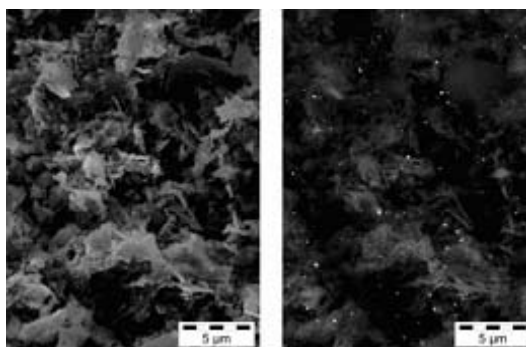

Figure 4: SEM of a deposited catalytic layer (Pt_{1.7} = 1.7% Pt dispersed in alumina); left: secondary electron image; right: backscattering electron image.

III.3. Sensing characteristics of the sensor with a Pt/alumina catalytic layer

As it is seen in Figure 3, the strong sensor response to CO would significantly influence the NO_x signal if not eliminated. By depositing a catalytic layer consisting of Pt_{1.7} the sensor response to CO can be suppressed at a temperature above 300 °C as the catalytic properties of the Pt/alumina layer are sufficient to fully oxidize CO to the non-reactive gas CO₂. Measurements presented in Figure 5 were shifted from the optimum temperature of 450 °C as mentioned in Section III.1. to 520 °C with a loss of sensibility of approximately 5 mV. This temperature increase was necessary to avoid a deactivation of the platinum, as discussed in the next paragraph.

If furthermore both NO and NO₂ were considered, it is necessary to avoid a cancelling out of the overall sensing response to NO_x, as NO and NO₂ lead to opposite signals. Therefore it is preferable to obtain a NO/NO₂ ratio which is only dependent on the working temperature. Platinum is said to be an efficient catalyst to catalyse NO and NO₂ to the thermodynamic equilibrium. Therefore, independently on the NO/NO₂ ratio arriving at the sensor, a ratio according to the thermodynamic equilibrium is achieved by passing through the catalytic filter and the same response should be obtained proportional to the overall NO_x concentration. This theory is in very good agreement with our experimental results as a

response with a similar magnitude of approximately 20 mV was obtained for an injection of 200 ppm of NO or NO₂ at 520 °C. According to the thermodynamical equilibrium the ratio of NO/NO₂ should be close to 1 at this temperature. Therefore, as the sensor is more sensitive to NO₂ than to NO, the sensor signal was negative (Figure 5).

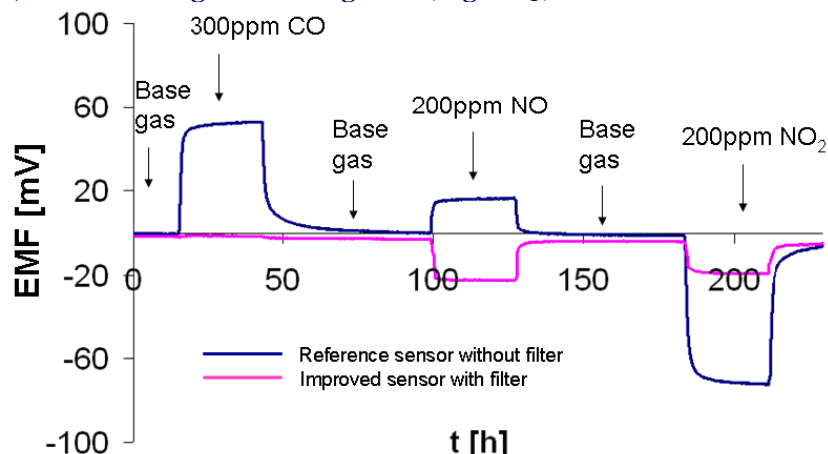

Figure 5: Response of a sensor with a catalytic layer (Pt1.7 = 1.7% Pt dispersed in alumina) to CO, NO and NO₂ at 520 °C in the presence of 12 vol.% O₂, 2 vol.% H₂O and N₂ balance.

III.4. Deactivation and regeneration of the catalytic filter layer

Figure 6 shows a typical progression of the deactivation of the sensor response at 450 °C. At the beginning of the experiment, a full oxidation of CO was achieved, therefore no response to CO was observed. After 2 h of permanent exposure to a gas mixture containing 200 ppm of NO₂ in 12% oxygen, the catalytic performance of the filter dropped. CO could not be any longer totally converted to CO₂ and a small response of the order of +10 mV to CO was observed. This response became more important, reaching +15 mV if the sensor was further exposed to NO₂ for 3 h.

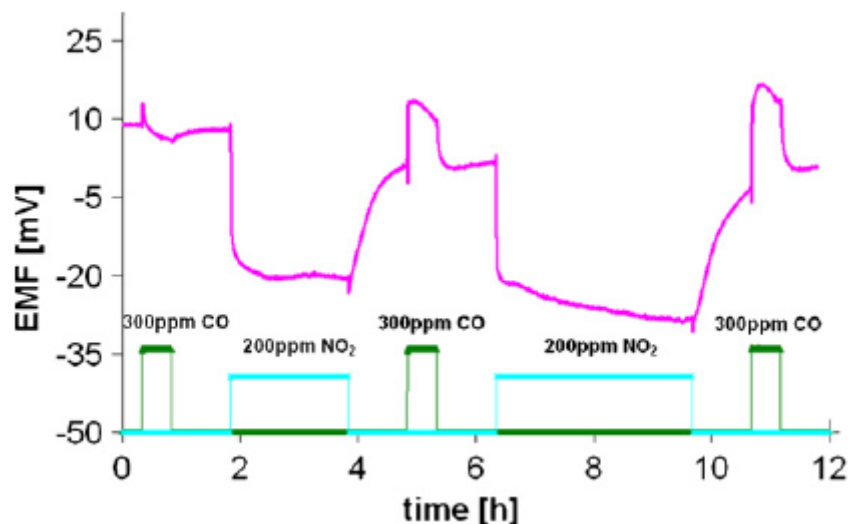

Figure 6: Deactivation process of the catalytic layer (Pt1.7 = 1.7% Pt dispersed in alumina) at 450 °C in the presence of 12 vol.% O₂, 2 vol.% H₂O and N₂ balance.

However, this kind of deactivation is reversible. It was found that a deactivated sensor could be regenerated by a calcination procedure. Figure 7 shows a sensor with a deactivated filter which responded to 300 ppm CO at the beginning of the test (EMF of about +10 mV). The sensor was then heated at 700 °C for 1 h before it was cooled down back to 450 °C. The baseline response shifted to a higher background value, but when the sensor was exposed

again to CO (300 ppm in air), no response was observed, suggesting that the catalytic properties of the filter were reactivated.

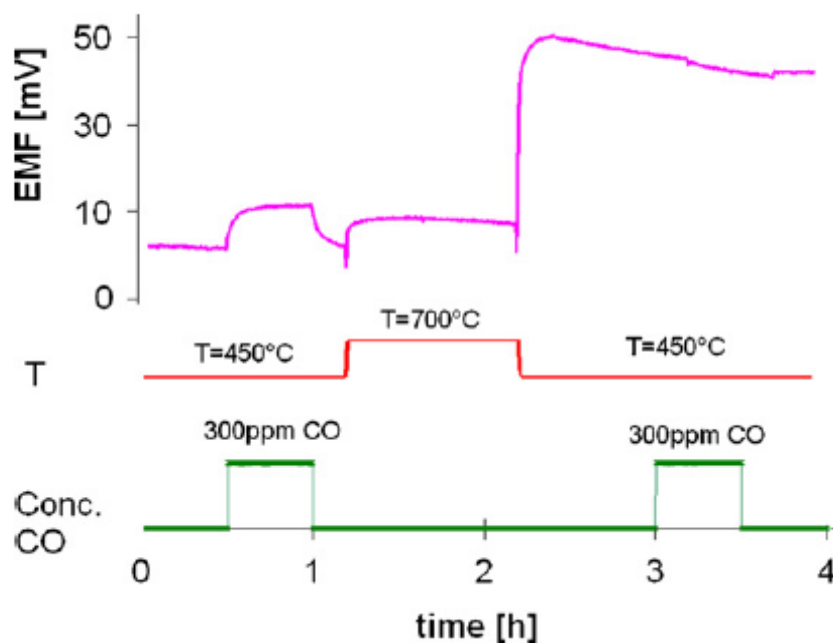

Figure 7: Regeneration process of the catalytic layer (Pt1.7 = 1.7% Pt dispersed in alumina) in the presence of 12 vol.% O₂, 2 vol.% H₂O and N₂ balance.

III.5. Adsorption and desorption behaviour of the catalyst

In order to gain further knowledge of the deactivation/regeneration behaviour, temperature-program desorption (TPD) experiments have been carried out on the same Pt1.7 powder which was used for the elaboration of the catalytic filter. Before the TPD experiments, the powdered catalyst was calcinated in air at 850 °C for 1 h in order to simulate the deposition procedure of the filter. Figure 8 shows the NO (30 amu) and oxygen (32 amu) desorption profiles in helium after a pre-treatment of the catalyst in 300 ppm NO₂/3.5% O₂ atmosphere for 12 h at 450 °C, the temperature at which deterioration of the sensing responses was observed.

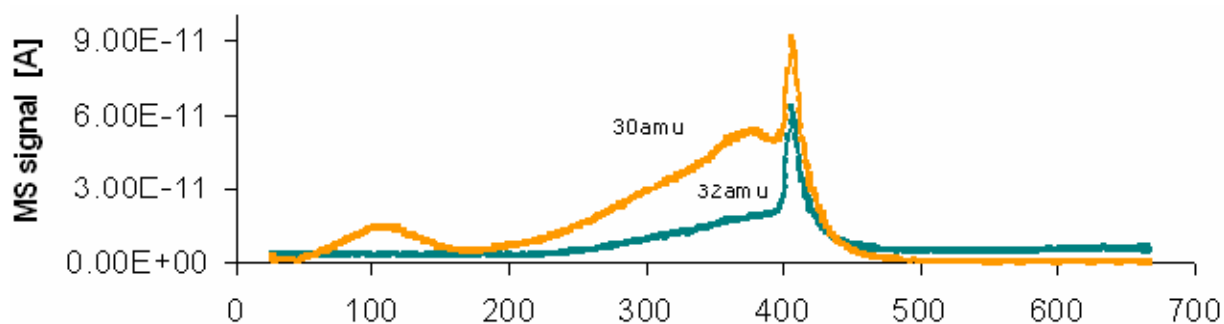

Figure 8: TPD in helium of a 1.7% Pt dispersed in alumina catalyst after a pre-treatment of 12 h in 300 ppm NO₂, 3.5% O₂ and He balance at 450 °C.

TPD spectrum of NO desorption exhibits two peaks. The first peak centred at 100 °C is believed to represent NO chemisorbed on platinum as reported in the literature [21]. The peak integration gives a value of 11 μmol of NO adsorbed on Pt per gram of catalyst. Considering one Pt atom for one NO molecule, the Pt dispersion can be estimated to be 12.6%. As the desorption of these species is already completed at around 150 °C, it seems to be justified to presume that it will not affect the sensor function at 450 °C.

The second desorption peak starts at approximately 200 °C and continues up to 460 °C. The amount of NO desorbed is calculated to be 88 $\mu\text{mol/g}$. As oxygen desorption (at 32 amu) takes place at the same time, this peak is believed to belong to decomposition of nitrates or nitrites adsorbed on the alumina support [22] which generates simultaneous desorption of NO and O₂. It should be noted here that the concentration of desorbed nitrates and nitrites corresponds to the overall amount of Pt (87 $\mu\text{mol/g}$). This suggests that these species could be formed on or around the Pt particles, thus decreasing their catalytic properties.

These results correspond well with the experimental observations of the sensor. At temperatures lower than 500 °C, nitrates and nitrites are not decomposed, which causes deactivation of the catalytic layer. This explains deterioration of the sensor responses observed at 450 °C. At higher operating temperatures, desorption of nitrates and nitrites takes place. This process regenerates the catalytic properties of the filter. Moreover, if the working temperature above 500 °C is maintained, no deactivation is observed.

III.6. Interference of hydrocarbons

Hydrocarbons (HC) are apart from CO the most important interference species for NO_x sensors in car exhaust. Therefore it is absolutely necessary to suppress the sensor response to these gaseous species by oxidizing them to CO₂ and H₂O. In a catalytic flow experiment it was determined that 125 mg of the Pt1.7 catalyst, calcinated 1 h at 850°, can fully oxidize 500 ppm propane and/or propene from 400 °C. However, as expected, a full conversion of methane was not reached below 500 °C.

Figure 9 shows the response of two sensors with different contents of platinum dispersed on the catalytic filter. The sensors were exposed at 450 °C and 500 °C to a hydrocarbon mixture (25% methane, 25% butane and 50% propene) in 12% oxygen. As expected, in the absence of a catalytic filter, the sensor responses to the hydrocarbon mixture are important in the order of 10–50 mV as observed in the presence of CO. These interferences are attenuated by adding a catalytic filter of the type Pt1.7. However, the sensor responses are not completely removed suggesting that the filter layer has not been able to fully oxidize 50 ppm of the HC mixture even at 500 °C. Though, when the percentage of platinum was raised in the catalytic layer up to 4.5 wt.% the sensor responses to the HC mixture are very weak at 450 °C and completely suppressed at 500 °C.

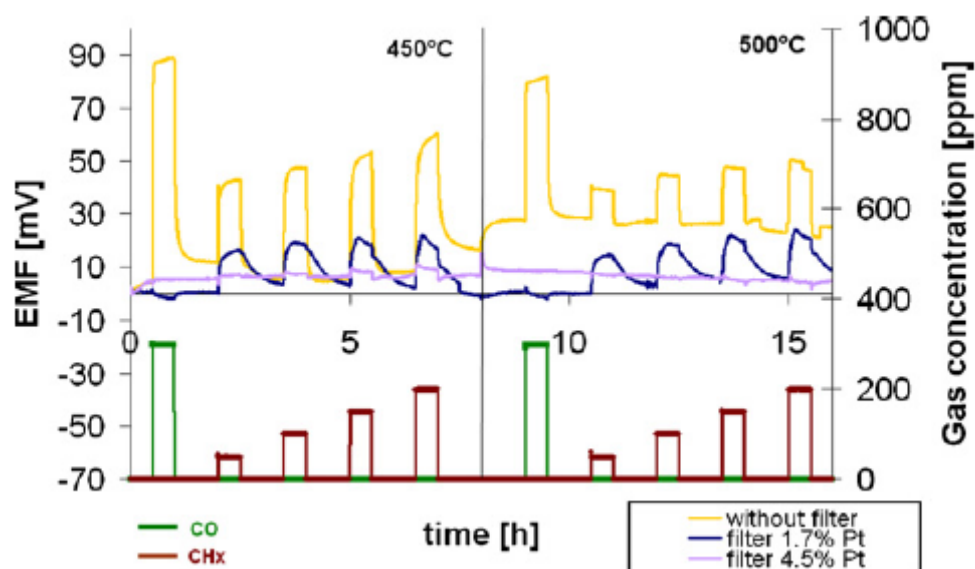

Figure 9: Sensor response to hydrocarbons (HC = 25% methane, 25% butane and 50% propene) at 450 °C and 500 °C, respectively, in the presence of 12 vol.% O₂, 2 vol.% H₂O and N₂ balance.

As mentioned in Section I, the idea of reducing interferences by using a catalyst is well discussed in the literature [18], [19] and [23], zeolite filters such as NaY or PtY seem to be among the most successful ones in the application [24] and [13]. The choice using Pt on

alumina support is driven by the easy preparation process and high reproducibility which are well suited for industrial fabrication.

IV. Conclusions

A simple robust Pt/YSZ/Au NO_x sensor is presented in this work. It is shown that by depositing a catalytic filter layer over the sensing elements, CO and light hydrocarbon interferences to the NO_x signal can be totally cancelled, yielding to a higher NO_x selectivity. By using TPD analysis an optimal working temperature can be found to avoid deactivation of the catalytic filter. It is shown that it is advisable to work at a temperature higher than 500 °C to force nitrates or nitrites decomposition. However once selectivity is achieved, an improvement in the sensitivity is necessary to grant industrial application. Therefore, lower temperatures may be necessary in order to achieve higher sensitivity of the signal. In that case, a calcination step of the sensor at 700 °C can be applied to regenerate the catalytic activity of the filter layer.

References

- [1] Ono, M. Hasei, A. Kunimoto and N. Miura, *Solid State Ionics* 175 (1–4) (2004), pp. 503–506
- [2] X. Li, W. Xiong and G.M. Kale, *Electrochemical Solid-State Letter* 8 (2005), pp. H27–H30.
- [3] F. Menil, V. Coillard and C. Lucat, *Sensors and Actuators B: Chemical* 67 (2000), pp. 1–23.
- [4] E. Billi, J.-P. Viricelle, L. Montanaro and C. Pijolat, *IEEE Sensors Journal* 2 (2002).
- [5] J.W. Fergus, *Sensors and Actuators B: Chemical* 122 (2007), pp. 683–693.
- [6] P.T. Moseley, *Solid state gas sensors*, *Measurement Science Technology* 8 (1997), pp. 223–237.
- [7] U. Guth and J. Zosel, *Ionics* 10 (2004), pp. 366–377.
- [8] N. Guillet, R. Lalauze and C. Pijolat, *Sensors and Actuators B: Chemical* 98 (2004), pp. 130–139.
- [9] C. Pupier, C. Pijolat, J.C. Marchand and R. Lalauze, *Journal of Electrochemical Society* 146 (1999), pp. 2360–2364.
- [10] E.L. Brosha, R. Mukundan, R. Lujan and F.H. Garzon, *Sensors and Actuators B: Chemical* 119 (2006), pp. 398–408.
- [11] P. Viricelle, A. Pauly, L. Mazet, J. Brunet, M. Bouvet, C. Varenne and C. Pijolat, *Materials Science and Engineering: C* 26 (2–3) (2006), pp. 186–195.
- [12] J.C. Yang and P.K. Dutta, *Sensors and Actuators B: Chemical* 123 (2007), pp. 929–936.
- [13] N.F. Szabo and P.K. Dutta, *Sensors and Actuators B: Chemical* 88 (2003), pp. 168–177.
- [14] S. Zhuiykov and N. Miura, *Sensors and Actuators B: Chemical* 121 (2007), pp. 639–651.
- [15] Xiong and G.M. Kale, *Sensors and Actuators B: Chemical* 114 (2006), pp. 101–108.
- [16] N. Miura, M. Nakatou and S. Zhuiykov, *Ceramics International* 30 (2004), pp. 1135–1139.
- [17] J.W. Fergus, *Sensors and Actuators B: Chemical* (2007), pp. 652–663.
- [18] M. Ono, K. Shimano, N. Miura and N. Yamazoe, *Solid State Ionics* 136/137 (2000), pp. 583–588.
- [19] S. Kitsukawa, H. Nakagawa, K. Fukuda, S. Asakura, S. Takahashi and T. Shigemori, *Sensors and Actuators B: Chemical* 65 (2000), p. 121.
- [20] A. Morata, J.P. Viricelle, A. Tarancon, G. Dezanneau, C. Pijolat, F. Peiro and J.R. Morante, *Sensors and Actuators B: Chemical* 130 (2008), pp. 561–566.
- [21] S. Benard, L. Retailleau, F. Gaillard, P. Vernoux and A. Giroir-Fendler, *Applied Catalysis B: Environmental* 55 (2005), pp. 11–21.
- [22] R. Burch, J.A. Sullivan and T.C. Watling, *Catalysis Today* 42 (1998), p. 1.
- [23] K. Sahner, G. Hagen, D. Schönauer, S. Reiss and R. Moos, *Solid State Ionics* 179 (2008), pp. 2416–2423.
- [24] N.F. Szabo, H. Du, S.A. Akbar, A. Soliman and P. Dutta, *Sensors and Actuators B: Chemical* 82 (2002), pp. 142–149.