



HAL
open science

Reliable homotopy continuation

Joris van der Hoeven

► **To cite this version:**

| Joris van der Hoeven. Reliable homotopy continuation. 2011. hal-00589948v1

HAL Id: hal-00589948

<https://hal.science/hal-00589948v1>

Submitted on 2 May 2011 (v1), last revised 3 Jan 2015 (v4)

HAL is a multi-disciplinary open access archive for the deposit and dissemination of scientific research documents, whether they are published or not. The documents may come from teaching and research institutions in France or abroad, or from public or private research centers.

L'archive ouverte pluridisciplinaire **HAL**, est destinée au dépôt et à la diffusion de documents scientifiques de niveau recherche, publiés ou non, émanant des établissements d'enseignement et de recherche français ou étrangers, des laboratoires publics ou privés.

RELIABLE HOMOTOPY CONTINUATION*

Preliminary version

Joris van der Hoeven

LIX, CNRS
École polytechnique
91128 Palaiseau Cedex
France

Email: vdhoeven@lix.polytechnique.fr

Web: <http://lix.polytechnique.fr/~vdhoeven>

May 2, 2011

In this paper, we present several algorithms for certified homotopy continuation. One typical application is to compute the roots of a zero dimensional system of polynomial equations. We both present algorithms for the certification of single and multiple roots. We also present several ideas for improving the underlying numerical path tracking algorithms, especially in the case of multiple roots.

KEYWORDS: Homotopy continuation, polynomial system solving, ball arithmetic, interval arithmetic, reliable computing

A.M.S. SUBJECT CLASSIFICATION: 65H20, 65H04, 65G20, 30C15, 13P15

Disclaimer. This paper is a preliminary version, which is mainly intended as a working program for an ongoing implementation in the MATHEMAGIX system. It is expected that several adjustments and corrections will have to be made during the implementation of the algorithms in this paper and their proof reading by colleagues.

1. INTRODUCTION

Besides Gröbner basis computations, homotopy methods are a popular technique for solving systems of polynomial equations. In this paper, we will only consider zero dimensional systems. Given such a system

$$P(z) = 0, \tag{1}$$

with $P = (P_1, \dots, P_n)$ and $z = (z_1, \dots, z_n)$, the idea is to find a suitable starting system

$$Q(z) = 0 \tag{2}$$

of which all solutions are known, to introduce the homotopy

$$H(z, t) = (1 - t)P(z) + tQ(z), \tag{3}$$

and to compute the solutions to $P(z) = 0$ by following the solutions of $Q(z) = 0$ from $t = 1$ to $t = 0$. Two main approaches exist:

Algebraic homotopies. In this setting, the polynomial equations have exact rational or algebraic coefficients. The homotopy continuation is done exactly using suitable resultants. At the end of the homotopy, the solutions of the system $P(z) = 0$ are again given exactly, as the solutions of simpler systems. The theory was developed

*. This work has been supported by the ANR-09-JCJC-0098-01 MAgIX project, the Digiteo 2009-36HD grant and Région Ile-de-France.

in [GHMP95, GHHM+97, Dur08] and a concrete implementation is available in the KRONECKER system [Lec01].

Numeric homotopies. An alternative approach is to follow the solution paths using a numeric path tracking algorithm; see [Mor87, Ver96, SW05] and references therein. This approach is usually faster, partly because most of the operations can be done at a significantly lower precision. However, the end result is only approximate. In particular, it cannot be used for the reliable resolution of overdetermined systems. Several implementations exist for numeric path tracking [Ver99, BHSW06, Ley09].

It is surprising that little effort has been undertaken so far in order to bring both approaches closer together. Particularly interesting challenges are how to make numeric homotopy as reliable as possible and how to reconstruct exact end results from the numeric output. Part of this situation might be due to the fact that interval analysis [Moo66, AH83, Neu90, JKDW01, Kul08, MKC09, Rum10] is not so well-known in the communities where homotopy methods were developed, with the exception of one early paper [Kea94]. The main objective paper is to systematically exploit interval analysis techniques in the context of homotopy continuation. We will show how to certify homotopy continuations as well as single and multiple solutions of the polynomial system $P(z) = 0$.

Section 3 is devoted to preliminaries from the area of reliable computation. In section 3.1, we start by recalling the basic principles of ball arithmetic [vdH09], which is a more suitable variant of interval arithmetic for our purposes. In section 3.2, we pursue by recalling the concept of a Taylor model [MB96, MB04], which is useful in order to compute with reliable enclosures of multivariate analytic functions on polydisks. We also introduce a variant of Taylor models in section 3.3, which simultaneously encloses an analytic function and a finite number of its derivatives. In sections 3.4 and 3.5, we discuss the well known problem of overestimation which is inherent to ball arithmetic. We will provide some techniques to analyze, quantify and reduce overestimation.

Before attacking the topic of certified path tracking, it is useful to review the theory of numeric path tracking first. In section 4, we start with the case of non singular paths, in which case we use a classical predictor corrector approach based on Euler-Newton's method. The goal of a numeric path tracker is to advance as fast as possible on the solution path while minimizing the risk of errors. Clearly, the working precision has to be sufficiently large in order to ensure that function evaluations are reasonably accurate. In section 4.4, we show how to find a suitable working precision using ball arithmetic. We consider this approach to be simpler, more robust and more general than the one proposed in [BSHW08]. In order to reduce the risk of jumping from one path to another path, we also need a criterion for checking whether our numeric approximations stay reasonably close to the true solution path. A numerically robust way to do this is to ensure that the Jacobian of H does not change too rapidly during each step; see section 4.5 and [BSHW08] for a related approach. Another technique is to detect near collisions of paths and undertake special action in this case; see section 4.6.

In section 5, we turn our attention to homotopies (3) such that the end system (1) admits multiple solutions. We will see that Euler-Newton iterations only admit a linear convergence near multiple solutions. Therefore, it is useful to search for alternative iterations which admit a better convergence. Now the solution path near a multiple solution is given by a convergent Puiseux series in t . When letting $t \rightarrow e^{2\pi i} t$ turn around the origin, we thus fall on another solution path. The collection of paths which are obtained through repeated rotations of this kind is called a herd. In sections 5.2 and 5.3, we will describe a new path tracking method with quadratic convergence, which operates simultaneously on all paths in a herd. The remaining issue of how to detect clusters and herds will be described in sections 5.4, 5.5 and 5.6.

In section 6, we turn our attention to the certification of single roots of (1) and single steps of a path tracker. An efficient and robust method for the certification of solutions to systems of non linear equations is Krawczyk’s method [Kra69], with several improvements by Rump [Rum80]. In section 6.1, we adapt this classical method to the setting of ball arithmetic. In section 6.2, we will see that an easy generalization of this method provides an algorithm for certified path tracking. An alternative such algorithm was given in [Kea94], but the present algorithm presents similar advantages as Krawczyk’s method with respect to other methods for the certification of solutions to systems of non linear equations. However, both methods still suffer from overestimation due to the fact that error bounds are computed on a polydisk which contains the solution path. Using the technique of Taylor models, we will show in section 6.3 that it possible to compute the error bounds in small tubes around the actual solution path, thereby reducing the problem of overestimation.

In the last section, we consider the more difficult problem of certifying multiple roots. Deflation is a classical technique in order to solve this difficulty. However, deflation usually requires the computation of a large number of derivatives of the system, which becomes prohibitive for large clusters of solutions. Notice that solutions which tend to infinity should also be considered as being part of one or more large clusters if we want to compute *all* solutions to (1). Our certification strategy is again based on the simultaneous consideration of all solution paths in a herd. In sections 7.2 and 7.3, we will show that a herd of solution paths can be considered as a single isolated solution path of a new “suitable fattened” system of equations. From the complexity point of view, if the herd contains r paths, then the evaluation of the fattened system is only r times more expensive than the evaluation of the original system, up to logarithmic factors. Moreover, a single large cluster often contains many different herds, which can be considered separately for our technique. This is particularly useful for the separation of the various paths which tend to infinity. In section 7.4, we will show how to certify the global set of solutions to the system $f(z) = 0$ and how to reconstruct equations for the exact solutions.

2. NOTATIONS

Positive elements. Given a subset $R \subseteq \mathbb{R} \cup \{\pm\infty\}$, we denote

$$\begin{aligned} R^{\geq} &= \{x \in R: x \geq 0\} \\ R^{>} &= \{x \in R: x \neq 0\} \end{aligned}$$

Vector notation. Unless stated otherwise, we will use the L_1 -norm for vectors $u \in \mathbb{C}^n$:

$$\|u\| = |u_1| + \dots + |u_n|. \tag{4}$$

This norm should not be confused with taking componentwise absolute values

$$|u| = (|u_1|, \dots, |u_n|)$$

For $u, v \in \mathbb{R}^n$ we also define

$$\begin{aligned} u \leq v &\Leftrightarrow u_1 \leq v_1 \wedge \dots \wedge u_n \leq v_n \\ u < v &\Leftrightarrow u_1 < v_1 \wedge \dots \wedge u_n < v_n \\ \max(u, v) &= (\max(u_1, v_1), \dots, \max(u_n, v_n)) \\ u \cdot v &= u_1 v_1 + \dots + u_n v_n \end{aligned}$$

If z_1, \dots, z_n are formal variables, then we write

$$z^u = z_1^{u_1} \dots z_n^{u_n}$$

Matrix notation. We write $\mathbb{K}^{r \times c}$ for the set of $r \times c$ matrices over a set \mathbb{K} . The matrix norm of a matrix $M \in \mathbb{C}^{r \times c}$ corresponding to the L_1 -norm (4) for vectors

$$\begin{aligned} \|M\| &= \sup_{\|z\|=1} \|Mz\| \\ &= \sum_i \max_j |M_{i,j}|. \end{aligned}$$

Directed acyclic graphs. We recall that labeled directed acyclic graphs are often used for the representation of symbolic expressions with potential common subexpressions. For instance,

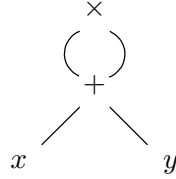

is a typical dag for the expression $(x + y)^2$. We will denote by s_f the size of a dag f . For instance, the size of the above dag is $s_f = 4$.

3. RELIABLE ARITHMETIC

3.1. Ball arithmetic

Let us briefly recall the principles behind ball arithmetic. Given a normed vector space \mathbb{K} , we will denote by \mathbb{K} or $\mathcal{B}(\mathbb{K}, \mathbb{R})$ the set of closed balls with centers in \mathbb{K} and radii in \mathbb{R}^{\geq} . Given such a ball $z \in \mathcal{B}(\mathbb{K}, \mathbb{R})$, we will denote its center by $\text{cen}(z)$ and its radius by $\text{rad}(z)$. Conversely, given $z \in \mathbb{K}$ and $r \in \mathbb{R}$, we will denote by $z + \mathcal{B}(r)$ the closed ball with center z and radius r .

A continuous operation $f: \mathbb{K}^d \rightarrow \mathbb{K}$ is said to *lift* into an operation $f^{\text{lift}}: \mathbb{K}^d \rightarrow \mathbb{K}$ on balls, which is usually also denoted by f , if the *inclusion property*

$$f(x_1, \dots, x_d) \in f(\mathbf{x}_1, \dots, \mathbf{x}_d) \quad (5)$$

is satisfied for any $\mathbf{x}_1, \dots, \mathbf{x}_d \in \mathbb{K}$ and $x_1 \in \mathbf{x}_1, \dots, x_d \in \mathbf{x}_d$. We also say that $f(\mathbf{x}_1, \dots, \mathbf{x}_d)$ is an *enclosure* for the set $\{f(x_1, \dots, x_d) : x_1 \in \mathbf{x}_1, \dots, x_d \in \mathbf{x}_d\}$, whenever (5) holds. For instance, if \mathbb{K} is a Banach algebra, then we may take

$$\begin{aligned} \mathbf{x} + \mathbf{y} &= \text{cen}(\mathbf{x}) + \text{cen}(\mathbf{y}) + \mathcal{B}(\text{rad}(\mathbf{x}) + \text{rad}(\mathbf{y})) \\ \mathbf{x} - \mathbf{y} &= \text{cen}(\mathbf{x}) - \text{cen}(\mathbf{y}) + \mathcal{B}(\text{rad}(\mathbf{x}) + \text{rad}(\mathbf{y})) \\ \mathbf{x} \mathbf{y} &= \text{cen}(\mathbf{x}) \text{cen}(\mathbf{y}) + \mathcal{B}(\text{rad}(\mathbf{x}) (|\text{cen}(\mathbf{y})| + \text{rad}(\mathbf{y})) + |\text{cen}(\mathbf{y})| \text{rad}(\mathbf{x})). \end{aligned}$$

Similar formulas can be given for division and elementary functions. Certified upper and lower bounds for $|\mathbf{x}|$ will be denoted by $\lceil \mathbf{x} \rceil = |\text{cen}(\mathbf{x})| + \text{rad}(\mathbf{x})$ and $\lfloor \mathbf{x} \rfloor = \max \{0, |\text{cen}(\mathbf{x})| - \text{rad}(\mathbf{x})\}$.

It is convenient to extend the notion of a ball to more general radius types, which only carry a partial ordering. This allows us for instance to regard a vector $\mathbf{x} = (x_1, \dots, x_d) \in \mathcal{B}(\mathbb{K}, \mathbb{R})^d$ of balls as a “vectorial ball” with center $\text{cen}(\mathbf{x}) = (\text{cen}(x_1), \dots, \text{cen}(x_d)) \in \mathbb{K}^d$ and radius $\text{rad}(\mathbf{x}) = (\text{rad}(x_1), \dots, \text{rad}(x_d)) \in \mathbb{R}^d$. If $x = (x_1, \dots, x_d) \in \mathbb{K}^d$, then we write $x \in \mathbf{x}$ if and only if $x_i \in x_i$ for all $i \in \{1, \dots, d\}$. A similar remark holds for matrices and power series with ball coefficients.

In concrete machine computations, numbers are usually approximated by floating point numbers with a finite precision. Let $\tilde{\mathbb{R}}$ be the set of floating point numbers at a given working precision, which we will assume fixed. It is customary to include the infinities $\pm\infty$ in $\tilde{\mathbb{R}}$ as well. The IEEE754 standard [ANS08] specifies how to perform basic arithmetic with floating point numbers in a predictable way, by specifying a rounding mode $R \in \{\downarrow, \uparrow, \updownarrow\}$ among “down”, “up” and “nearest”. A multiple precision implementation of this standard is available in the MPFR library [HLRZ00]. Given an operation $f: \mathbb{R}^d \rightarrow \mathbb{R}$, we will denote by $f^R: \tilde{\mathbb{R}}^d \rightarrow \tilde{\mathbb{R}}$ its approximation using floating pointing arithmetic with rounding mode R . This notation extends to the case when \mathbb{R} and $\tilde{\mathbb{R}}$ are replaced by their complexifications \mathbb{C} and $\tilde{\mathbb{C}} = \tilde{\mathbb{R}}[i]$.

Let $\mathbb{K} = \mathbb{R}$ and $\tilde{\mathbb{K}} = \tilde{\mathbb{R}}$ or $\mathbb{K} = \mathbb{C}$ and $\tilde{\mathbb{K}} = \tilde{\mathbb{C}}$. We will denote by $\tilde{\mathbb{K}}$ or $\mathcal{B}(\tilde{\mathbb{K}}, \tilde{\mathbb{R}})$ the set of closed balls in \mathbb{K} with centers in $\tilde{\mathbb{K}}$ and radii in $\tilde{\mathbb{R}}^{\geq}$. In this case, we will also allow for balls with an infinite radius. A continuous operation $f: \mathbb{K}^d \rightarrow \mathbb{K}$ is again said to *lift* to an operation $f: \tilde{\mathbb{K}}^d \rightarrow \tilde{\mathbb{K}}$ on balls if (5) holds for any $\mathbf{x}_1, \dots, \mathbf{x}_d \in \tilde{\mathbb{K}}$ and $x_1 \in \mathbf{x}_1, \dots, x_d \in \mathbf{x}_d$. The formulas for the ring operations may now be adapted to

$$\begin{aligned} \mathbf{x} + \mathbf{y} &= \text{cen}(\mathbf{x}) + \uparrow \text{cen}(\mathbf{y}) + \mathcal{B}(\text{rad}(\mathbf{x}) + \uparrow \text{rad}(\mathbf{y}) + \uparrow \epsilon_{+, \mathbf{x}, \mathbf{y}}) \\ \mathbf{x} - \mathbf{y} &= \text{cen}(\mathbf{x}) - \downarrow \text{cen}(\mathbf{y}) + \mathcal{B}(\text{rad}(\mathbf{x}) + \uparrow \text{rad}(\mathbf{y}) + \uparrow \epsilon_{-, \mathbf{x}, \mathbf{y}}) \\ \mathbf{x} \mathbf{y} &= \text{cen}(\mathbf{x}) \times \downarrow \text{cen}(\mathbf{y}) + \\ &\quad \mathcal{B}(\text{rad}(\mathbf{x}) \times \uparrow (|\text{cen}(\mathbf{y})| + \uparrow \text{rad}(\mathbf{y})) + \uparrow |\text{cen}(\mathbf{y})| \times \uparrow \text{rad}(\mathbf{x}) + \uparrow \epsilon_{\times, \mathbf{x}, \mathbf{y}}), \end{aligned}$$

where $\epsilon_{+, \mathbf{x}, \mathbf{y}}$, $\epsilon_{-, \mathbf{x}, \mathbf{y}}$ and $\epsilon_{\times, \mathbf{x}, \mathbf{y}}$ are reliable bounds for the rounding errors induced by the corresponding floating point operations on the centers; see [vdH09] for more details.

In order to ease the remainder of our exposition, we will avoid technicalities related to rounding problems, and compute with “idealized” balls with centers in $\mathbb{K} \in \{\mathbb{R}, \mathbb{C}\}$ and radii in \mathbb{R}^{\geq} . For those who are familiar with rounding errors, it should not be difficult though to adapt our results to more realistic machine computations.

Remark 1. In classical interval analysis so called interval lifts of operations $f: \mathbb{K}^d \rightarrow \mathbb{K}$ are sometimes required to satisfy the *inclusion monotonicity* property

$$\mathbf{x}_1 \subseteq \mathbf{y}_1 \wedge \dots \wedge \mathbf{x}_d \subseteq \mathbf{y}_d \implies f(\mathbf{x}_1, \dots, \mathbf{x}_d) \subseteq f(\mathbf{y}_1, \dots, \mathbf{y}_d),$$

for all $\mathbf{x}_1, \dots, \mathbf{x}_d, \mathbf{y}_1, \dots, \mathbf{y}_d \in \mathbb{K}$, which clearly implies the usual inclusion property (5). For floating intervals, it is easy to ensure this stronger property using correct rounding. In the ball setting, the exact ring operations in \mathbb{R} and \mathbb{C} are clearly inclusion monotonic, but it seems cumbersome to preserve this stronger property for floating balls. For this reason, we systematically develop our theory without assuming inclusion monotonicity.

3.2. Taylor models

If we are computing with analytic functions on a disk, or multivariate analytic functions on a polydisk, then Taylor models [MB96, MB04] provide a suitable functional analogue for ball arithmetic. We will use a multivariate setup with $z = (z_1, \dots, z_d)$ as our coordinates and a polydisk $D = \mathcal{B}(\rho) = \{z, |z| \leq |\rho|\}$ for a fixed $\rho = (\rho_1, \dots, \rho_d) \in (\mathbb{R}^>)^d$. Taylor models come in different blends, depending on whether we use a global error bound on D or individual bounds for the coefficients of the polynomial approximation. Individual bounds are sharper (especially if we truncate up to an small order such that the remainder is not that small), but more expensive to compute. Our general setup covers all possible blends of Taylor models.

We first need some more definitions and notations. Assume that \mathbb{N}^d is given the natural partial ordering. Let e_k denote the k -th canonical basis vector of \mathbb{N}^d , so that $(e_k)_k = 1$ and $(e_k)_l = 0$ for $l \neq k$. For every $i \in \mathbb{N}^d$, recall that $\|i\| = |i_1| + \dots + |i_d|$. A subset $\mathcal{I} \subseteq \mathbb{N}^d$ is called an *initial segment*, if for any $i \in \mathcal{I}$ and $j \in \mathbb{N}^d$ with $j \leq i$, we have $j \in \mathcal{I}$. In that case, we write $\dot{\mathcal{I}} = \{i \in \mathcal{I} : i + \{e_1, \dots, e_d\} \subseteq \mathcal{I}\}$ and $\partial\mathcal{I} = \mathcal{I} \setminus \dot{\mathcal{I}}$. In what follows, we assume that \mathcal{I} and \mathcal{J} are fixed initial segments of \mathbb{N}^d with $\dot{\mathcal{J}} \subseteq \mathcal{I}$. For instance, we may take $\mathcal{I} = \mathcal{T}_n = \{i \in \mathbb{N}^d : \|i\| \leq n\}$ and $\mathcal{J} = \mathcal{T}_{n+1}$ or $\mathcal{J} = \mathcal{T}_n$ or $\mathcal{J} = \{0\}$.

Let $\mathbb{K} = \mathbb{R}$ or $\mathbb{K} = \mathbb{C}$. Given a series $f = \sum_{i \in \mathbb{N}^d} f_i z^i \in \mathbb{K}[[z]]$, we will write $\text{supp } f = \{i \in \mathbb{N}^d : f_i \neq 0\}$ for its *support*. Given a subset $\mathbb{S} \subseteq \mathbb{K}[[z]]$ and a subset $\mathcal{S} \subseteq \mathbb{N}^d$, we write $f_{\mathcal{S}} = \sum_{i \in \mathcal{S}} f_i z^i$ and $\mathbb{S}_{\mathcal{S}} = \{g \in \mathbb{S} : \text{supp } g \subseteq \mathcal{S}\}$. If f is analytic on D , then we denote its sup-norm by

$$\|f\|_D = \sup_{z \in D} |f(z)|.$$

A *Taylor model* is a tuple $\mathbf{P} = (\rho, \mathcal{I}, \mathcal{J}, \text{cen}(\mathbf{P}), \text{rad}(\mathbf{P}))$, where ρ, \mathcal{I} and \mathcal{J} are as above, $\text{cen}(\mathbf{P}) \in \mathbb{K}[z]_{\mathcal{I}}$ and $\text{rad}(\mathbf{P}) \in \mathbb{R}[z]_{\mathcal{J}}$. We will write $\mathbb{T} = \mathbb{T}_{D, \mathcal{I}, \mathcal{J}} = \mathcal{B}_D(\mathbb{K}[z]_{\mathcal{I}}, \mathbb{R}[z]_{\mathcal{J}})$ for the set of such Taylor models. Given $\mathbf{P} \in \mathbb{T}$ and $i \in \mathbb{N}^d$, we will also denote $\mathbf{P} = \text{cen}(\mathbf{P}) + \mathcal{B}_D(\text{rad}(\mathbf{P}))$ and $\mathbf{P}_i = \text{cen}(\mathbf{P})_i + \mathcal{B}(\text{rad}(\mathbf{P})_i)$. Given an analytic function f on D , we write $f \in \mathbf{P}$, if there exists a decomposition

$$f = \text{cen}(\mathbf{P}) + \sum_{i \in \mathcal{J}} \varepsilon_i z^i$$

with $\varepsilon_i \in \mathbb{C}[[z]]$ and $\|\varepsilon_i\|_D \leq \text{rad}(\mathbf{P})_i$ for all i . In particular, if $f \in \mathbf{P}$, then

$$f(z) \in \sum_{i \in \mathcal{I} \cup \mathcal{J}} \mathbf{P}_i z^i,$$

for any $z \in D$. Given two Taylor models $\mathbf{P}, \mathbf{Q} \in \mathbb{T}$, we will say that \mathbf{P} is *included* in \mathbf{Q} , and we write $\mathbf{P} \subseteq \mathbf{Q}$ if $f \in \mathbf{Q}$ for any $f \in \mathbf{P}$. This holds in particular if $\mathbf{P}_i \subseteq \mathbf{Q}_i$ for all i , in which case we say that \mathbf{P} is *strongly included* in \mathbf{Q} and write $\mathbf{P} \sqsubseteq \mathbf{Q}$. We finally define $\varpi(\mathbf{P}) \in \mathbb{C}$ by

$$\varpi(\mathbf{P}) = \mathbf{P}_0 + \sum_{i \neq 0} \mathbf{P}_i \mathcal{B}(\rho)^i,$$

so that $f(z) \in \varpi(\mathbf{P})$ for all $f \in \mathbf{P}$ and $z \in \mathcal{B}(\rho)$.

Addition, subtraction and scalar multiplication are defined in a natural way on Taylor models. For multiplication, we need a projection $\pi = \pi_{\mathcal{J}} : \mathbb{N}^d \rightarrow \mathcal{J}$ with $\pi(i) \leq i$ for all i and $\pi(i) = i$ if $i \in \mathcal{J}$. One way to construct such a mapping is as follows. For $i \in \mathcal{J}$, we must take $\pi(i) = i$. For $i \notin \mathcal{J}$, let k be largest such that $i_k \neq 0$. Then we recursively define $\pi(i) = \pi(i - e_k)$. Given $\mathbf{P}, \mathbf{Q} \in \mathbb{T}$, we now define their product by

$$\mathbf{P}\mathbf{Q} = \sum_{i, j \in \mathcal{I}} \mathbf{P}_i \mathbf{Q}_j \mathcal{B}_D(\rho)^{i+j-\pi(i+j)} z^{\pi(i+j)}.$$

Using the observation that $z^{i+j} \in \mathcal{B}_D(\rho)^{i+j-\pi(i+j)} z^{\pi(i+j)}$, this product satisfies the inclusion property that $f g \in \mathbf{P}\mathbf{Q}$ for any analytic functions $f \in \mathbf{P}$ and $g \in \mathbf{Q}$ on D .

3.3. \mathcal{D} -stable Taylor models

For some applications, it is convenient to use Taylor models for enclosing both an analytic function and a certain number of its derivatives. Let us show how to incorporate this in our formalism. Throughout this section, we assume that $\mathcal{I} = \mathcal{J}$ and that \mathcal{D} is an initial segment with $\mathcal{D} \subseteq \mathcal{I}$.

Given a Taylor model $\mathbf{P} \in \mathbb{T}_{D, \mathcal{I}, \mathcal{I}}$ and $i \in D$, we notice that $\partial^i \mathbf{P} / \partial z^i$ can be regarded as a Taylor model in $\mathbb{T}_{D, \mathcal{I}', \mathcal{I}'}$ with $\mathcal{I}' = \{j \in \mathbb{N}^n : i + j \subseteq \mathcal{I}\}$. Let $f \in D \rightarrow \mathbb{C}$ be an analytic function and $\mathbf{Q} \in \mathbb{T}_{D, \mathcal{I}, \mathcal{I}}$. We define the relations $\in_{\mathcal{D}}$ and $\subseteq_{\mathcal{D}}$ by

$$\begin{aligned} f \in_{\mathcal{D}} \mathbf{P} &\iff \forall i \in D, \frac{\partial^i f}{\partial z^i} \subseteq \frac{\partial^i \mathbf{P}}{\partial z^i} \\ \mathbf{P} \subseteq_{\mathcal{D}} \mathbf{Q} &\iff \forall f \in_{\mathcal{D}} \mathbf{P}, f \in_{\mathcal{D}} \mathbf{Q}. \end{aligned}$$

Clearly, $\mathbf{P} \subseteq \mathbf{Q} \Rightarrow \mathbf{P} \subseteq_{\mathcal{D}} \mathbf{Q}$ for all \mathbf{P} and \mathbf{Q} .

Let $\omega: \mathbb{C}^d \rightarrow \mathbb{C}$ be an operation. Then ω is said to \mathcal{D} -lift to $\mathbb{T}_{D, \mathcal{I}, \mathcal{I}}$, if for all $\mathbf{P}_1, \dots, \mathbf{P}_d \in \mathbb{T}_{D, \mathcal{I}, \mathcal{I}}$ and all $f_1 \in_{\mathcal{D}} \mathbf{P}_1, \dots, f_d \in_{\mathcal{D}} \mathbf{P}_d$, we have $\omega \circ (f_1, \dots, f_d) \in_{\mathcal{D}} \omega(\mathbf{P}_1, \dots, \mathbf{P}_d)$. Addition, subtraction and scalar multiplication \mathcal{D} -lift in the usual way. As to multiplication, we take

$$\mathbf{P} \times_{\mathcal{D}} \mathbf{Q} = \sum_{\substack{i, j \in \mathcal{I} \\ i+j \in \mathcal{I}}} \mathbf{P}_i \mathbf{Q}_j z^{i+j} + \sum_{\substack{i, j \in \mathcal{I} \\ i+j \notin \mathcal{I} \\ k \in \partial \mathcal{I} \\ k \leq i+j}} C_{i, j, k} \mathbf{P}_i \mathbf{Q}_j \mathcal{B}_D(\rho)^{i+j-k} z^k,$$

with

$$C_{i, j, k} = \max_{\substack{l \in D \\ l \leq k}} \left(\frac{\partial^l z^{i+j}}{z^{i+j-l} \partial z^l} \Big/ \frac{\partial^l z^k}{z^{k-l} \partial z^l} \right).$$

In order to see that $\times_{\mathcal{D}}$ satisfies the \mathcal{D} -inclusion property, it suffices to check that

$$z^{i+j} \in_{\mathcal{D}} z^i \times_{\mathcal{D}} z^j$$

for all $i, j \in \mathcal{I}$. This is clear if $i + j \in \mathcal{I}$. Otherwise,

$$z^i \times_{\mathcal{D}} z^j = \sum_{\substack{k \in \partial \mathcal{I} \\ k \leq i+j}} C_{i, j, k} \mathcal{B}_D(\rho)^{i+j-k} z^k.$$

For any $l \in D$ with $l \leq i + j$, there exists a $k \in \partial \mathcal{I}$ with $l \leq k \leq i + j$. Hence,

$$\begin{aligned} \frac{\partial^l z^{i+j}}{\partial z^l} &= \frac{\partial^l z^{i+j}}{z^{i+j-l} \partial z^l} z^{i+j-l} \\ &\in \frac{\partial^l z^{i+j}}{z^{i+j-l} \partial z^l} \mathcal{B}_D(\rho)^{i+j-k} z^{k-l} \\ &= \frac{\partial^l}{\partial z^l} \left[\left(\frac{\partial^l z^{i+j}}{z^{i+j-l} \partial z^l} \Big/ \frac{\partial^l z^k}{z^{k-l} \partial z^l} \right) \mathcal{B}_D(\rho)^{i+j-k} z^k \right] \\ &\subseteq \frac{\partial^l (z^i \times_{\mathcal{D}} z^j)}{\partial z^l}. \end{aligned}$$

In the particularly useful case when $\mathcal{I} = \mathcal{J} = \mathcal{T}_1 = \{i \in \mathbb{N}^d : \|i\| \leq 1\}$, we notice that $C_{\mathbf{e}_i, \mathbf{e}_j, \mathbf{e}_i} = C_{\mathbf{e}_i, \mathbf{e}_j, \mathbf{e}_j} = 1$ for all $i \neq j$ and $C_{\mathbf{e}_i, \mathbf{e}_i, \mathbf{e}_i} = 2$ for all i .

3.4. Overestimation

The major problem in the area of ball arithmetic is overestimation. For example, even though the expression $x - x$ evaluates to zero for any $x \in \mathbb{R}$, its evaluation at any ball in \mathbb{R} with a non zero radius is not identically equal to zero. For instance,

$$(1 + \mathcal{B}(0.1)) - (1 + \mathcal{B}(0.1)) = \mathcal{B}(0.2).$$

Algorithms which rely on ball arithmetic have to be designed with care in order to avoid this kind of overly pessimistic error bounds. In particular, if we evaluate a dag using ball arithmetic, then a symbolically equivalent dag might lead to better error bounds.

Consider a continuous function $f: \mathbb{K}^d \rightarrow \mathbb{K}$ with \mathbb{K} as in section 3.1. We recall that f is said to lift into an operation $f^{\text{lift}}: \mathbb{K}^d \rightarrow \mathbb{K}$ if the inclusion property

$$f(x) \in f^{\text{lift}}(\mathbf{x})$$

is satisfied for all $\mathbf{x} \in \mathbb{K}^d$ and $x \in \mathbf{x}$. Clearly, such a lift is not unique: for any $\varepsilon: \mathbb{K}^d \rightarrow \mathbb{K}$ with $\text{cen } \varepsilon(\mathbf{x}) = 0$ for all \mathbf{x} , the function $f^{\text{alt}} = f^{\text{lift}} + \varepsilon$ is also a lift of f . If we require that $\text{cen } f^{\text{lift}}(\mathbf{x}) = f(\text{cen } \mathbf{x})$, then the best possible lift is given by

$$f^{\text{best}}(\mathbf{x}) = f(\text{cen } \mathbf{x}) + \mathcal{B}(\sup_{x' \in \mathbf{x}} |f(x') - f(\text{cen } \mathbf{x})|).$$

In general, this lift may be expensive to compute. Nevertheless, its existence suggest the following definition of the quality of a lift. The *overestimation* $\chi_{f^{\text{lift}}}(\mathbf{x})$ of f^{lift} at \mathbf{x} is defined by

$$\chi_{f^{\text{lift}}}(\mathbf{x}) = \frac{\text{rad } f^{\text{lift}}(\mathbf{x})}{\text{rad } f^{\text{best}}(\mathbf{x})}. \quad (6)$$

This quantity is easier to study if we let $\text{rad } \mathbf{x}$ tend to zero. Accordingly, we also define the *pointwise overestimation* function $\chi_{f^{\text{lift}}}: \mathbb{K}^d \rightarrow \mathbb{R}^{\geq}$ by

$$\chi_{f^{\text{lift}}}(x) = \limsup_{\varepsilon \rightarrow 0} \chi_{f^{\text{lift}}}(x + \varepsilon). \quad (7)$$

Here $\varepsilon \rightarrow 0$ means that $\text{cen } \varepsilon = 0$ and $\text{rad } \varepsilon \rightarrow 0$.

If f^{lift} is computed by evaluating a dag f , then it would be nice to have explicit formulas for the pointwise overestimation. For $\text{rad } \mathbf{x} \rightarrow 0$ and assuming that the lift f^{std} is evaluated using the default ball implementations of $+$, $-$ and \times from section 3.1, we claim that there exists a dag $\bar{\nabla} f$ with

$$\text{rad } f^{\text{std}}(x + \mathcal{B}(\varepsilon)) = (\bar{\nabla} f) \cdot |\varepsilon| + \mathcal{O}(\varepsilon^2),$$

for $\varepsilon \rightarrow 0$. Indeed, we may compute $\bar{\nabla} f$ using the rules

$$\begin{aligned} \bar{\nabla} c &= (0, \dots, 0) && (c \in \mathbb{K}) \\ \bar{\nabla} X_k &= (0, \overset{k-1}{\dots}, 0, 1, 0, \dots, 0) && (k \in \{1, \dots, r\}) \\ \bar{\nabla}(f \pm g) &= \bar{\nabla} f + \bar{\nabla} g \\ \bar{\nabla}(fg) &= (\bar{\nabla} f) |g| + |f| (\bar{\nabla} g), \end{aligned}$$

where X_k stands for the k -th coordinate function. Now we also have

$$\text{rad } f^{\text{best}}(x + \mathcal{B}(\varepsilon)) = |\nabla f| \cdot |\varepsilon| + \mathcal{O}(\varepsilon^2),$$

for $\varepsilon \rightarrow 0$. Consequently,

$$\chi_{f^{\text{std}}}(x) = \limsup_{\varepsilon \neq 0} \frac{(\bar{\nabla} f)(x) \cdot |\varepsilon|}{|(\bar{\nabla} f)(x)| \cdot |\varepsilon|}.$$

If $d = 1$, then this formula simplifies to

$$\chi_{f^{\text{std}}}(x) = \frac{(\bar{\nabla} f)(x)}{|f'(x)|}.$$

Example 2. With $d = 1$, let us compare the dags $f = X^2 - 2X + 1$ and $g = (X - 1)^2$. We have $\bar{\nabla} f = 2X + 2$ and $\bar{\nabla} g = 2|X - 1|$, whence

$$\begin{aligned} \chi_{f^{\text{std}}}(x) &= \frac{|x| + 1}{|x - 1|} \\ \chi_{g^{\text{std}}}(x) &= 1. \end{aligned}$$

The example shows that we have an infinite amount of overestimation near double zeros, except if the dag is explicitly given as a square near the double zero. More generally, for the dag $f = X^n - nX^{n-1} + \binom{n}{2}X^{n-2} + \dots + (-1)^n$ with an n -fold zero, we obtain

$$\chi_{f^{\text{std}}}(x) = \frac{(|x| + 1)^{n-1}}{|x - 1|^{n-1}}.$$

At a distance ε of the zero, ball arithmetic thus produces bounds which are $(2/\varepsilon)^{n-1}$ times too pessimistic.

Remark 3. An interesting problem is whether a good understanding of the pointwise overestimation also helps us to bound the overestimation on more general balls. One concrete question is whether we have

$$\text{rad } f^{\text{std}}(\mathbf{x}) \leq \left(\sup_{x \in \mathbf{x}} \chi_{f^{\text{std}}}(x) \right) \text{rad } f^{\text{best}}(\mathbf{x}),$$

for all polynomial dags f and balls \mathbf{x} . This inequality seems to hold in all easy cases that we have looked at, but we do not have a proof that it holds in general.

3.5. Reducing the overestimation

The example 2 shows that standard ball arithmetic generally produces an infinite amount of overestimation near double or multiple zeros. This raises the problem how to compute better ball lifts which do not present this drawback.

One possible remedy is to systematically compute the ball lifts using Taylor models. Indeed, assume that we want to evaluate f at the ball $\mathbf{x} = c + \mathcal{B}(\rho)$. Let $D = \mathcal{B}(\rho)$, \mathcal{I} and \mathcal{J} be as in section 3.2 and let $\mathbb{T} = \mathcal{B}_D(\mathbb{K}[\varepsilon]_{\mathcal{I}}, \mathbb{R}[\varepsilon]_{\mathcal{J}})$ be the corresponding domain of Taylor models in $\varepsilon = (\varepsilon_1, \dots, \varepsilon_d)$. Let $\xi = (x_1 + \varepsilon_1, \dots, x_n + \varepsilon_d) \in \mathbb{T}^d$ and consider the Taylor model evaluation of f at ξ

$$f(\xi) = P + \mathcal{B}_D(E).$$

Then

$$f^{\text{tay}}(\mathbf{x}) := P^{\text{std}}(\mathcal{B}(\rho)) + \mathcal{B}([\mathcal{E}^{\text{std}}(\mathcal{B}(\rho))])$$

yields an enclosure of $\{f(x) : x \in \mathbf{x}\}$. Although the evaluation of $f^{\text{tay}}(\mathbf{x})$ is usually far more expensive than the evaluation of $f^{\text{std}}(\mathbf{x})$, let us now study how much the overestimation has been reduced.

Let $\mathcal{F} = \mathbb{N}^d \setminus \mathcal{I}$ and let us introduce the operator $\bar{D}^{\mathcal{F}} : \varepsilon \mapsto \bar{D}^{\mathcal{F}}(\varepsilon)$, which generalizes the mapping $\varepsilon \mapsto \varepsilon \cdot \bar{\nabla}$. The operator is defined by induction over the size of f :

$$\begin{aligned} (\bar{D}^{\mathcal{F}} c)(\varepsilon) &= 0 && (c \in \mathbb{K}) \\ (\bar{D}^{\mathcal{F}} X_k)(\varepsilon) &= \begin{cases} 0 & \text{if } (0, \overset{k-1}{\dots}, 0, 1, 0, \dots, 0) \in \mathcal{I} \\ \varepsilon_k & \text{otherwise} \end{cases} && (k \in \{1, \dots, r\}) \\ (\bar{D}^{\mathcal{F}}(f \pm g))(\varepsilon) &= (\bar{D}^{\mathcal{F}} f)(\varepsilon) + (\bar{D}^{\mathcal{F}} g)(\varepsilon) \\ (\bar{D}^{\mathcal{F}}(fg))(\varepsilon) &= ((\bar{D}^{\mathcal{F}} f) |g| + |f| (\bar{D}^{\mathcal{F}} g))(\varepsilon) + \sum_{\substack{i, j \in \mathcal{I} \setminus \{0\} \\ i+j \in \mathcal{F}}} \frac{\varepsilon^{i+j}}{i! j!} |f^{(i)}| |g^{(j)}| \end{aligned}$$

For $\xi = (x_1 + \varepsilon_1, \dots, x_n + \varepsilon_d)$ as above, we then have

$$f(\xi) \subseteq \left(\sum_{i \in \mathcal{I}} \frac{1}{i!} f^{(i)}(x) \varepsilon^i \right) + \mathcal{B}_D((\bar{D}^{\mathcal{F}} f)(\rho)).$$

Now assume that $\mathcal{I} = \mathcal{J} = \mathcal{T}_n = \{i \in \mathbb{N}^d: \|i\| \leq n\}$ and let μ be the valuation of f at x . If $\mu < n$, then we have

$$\text{rad } f^{\text{best}}(x + \mathcal{B}(\rho)) = \sup_{\varepsilon \in \mathcal{B}(\rho)} \left| \sum_{\|i\|=\mu} \frac{1}{i!} f^{(i)}(x) \rho^i \right| + \mathcal{O}(\rho^{\mu+1}) \quad (8)$$

$$\text{rad } f^{\text{tay}}(x + \mathcal{B}(\rho)) = \sup_{\varepsilon \in \mathcal{B}(\rho)} \left| \sum_{\|i\|=\mu} \frac{1}{i!} f^{(i)}(x) \rho^i \right| + \mathcal{O}(\rho^{\mu+1}) \quad (9)$$

$$\chi_{f^{\text{tay}}}(x) = 1. \quad (10)$$

If $\mu = n$, then we still have (8), but (9) and (10) become

$$\begin{aligned} \text{rad } f^{\text{tay}}(x + \mathcal{B}(\rho)) &\leq (\bar{D}^{\mathcal{F}} f)(\rho) \\ \chi_{f^{\text{tay}}}(x) &= \limsup_{\varepsilon \neq 0} \frac{(\bar{D}^{\mathcal{F}} f)(\varepsilon)}{\left| \sum_{\|i\|=n} \frac{1}{i!} f^{(i)}(x) \varepsilon^i \right|}. \end{aligned}$$

If $\mu > n$, then we generally have

$$\chi_{f^{\text{tay}}}(x) = \infty,$$

although $\chi_{f^{\text{tay}}}(x) < \infty$ may occur in lucky cases.

4. NUMERIC PATH TRACKING

4.1. General framework

Let Ω be an open subset of \mathbb{C}^n and $H: \Omega \times \mathbb{C} \rightarrow \mathbb{C}^n$ an analytic function. We consider H as a function $H(z, t)$ in z and the *time* t , where $z \in \Omega$ and $t \in \mathbb{C}$, and also call H a *homotopy*. Assuming that $H(z_1, 1) = 0$ for some $z_1 \in \Omega$ and that we are not in a “degenerate” case, there exists a unique analytic function $[0, 1] \rightarrow \Omega: t \mapsto z_t$ with $H(z_t, t) = 0$ for all t . We are interested in the value of z_t when $t \rightarrow 0$. More generally, given a vector $z_1 = (z_1^1, \dots, z_1^k) \in \Omega^k$ of vectors, there exists a unique function $[0, 1] \rightarrow \Omega^k: t \mapsto z_t$ with $H(z_t^1, t) = \dots = H(z_t^k, t) = 0$ for all t .

The goal of a numeric path tracker is to approximate the function $t \mapsto z_t$ as well and as quickly possible and, above all, to compute its value z_0 at the “end point” $t = 0$. In what follows, we will denote by $\tilde{\mathbb{R}} = \mathbb{R}_p$ the set of floating point numbers with p bit mantissas. We also define $\tilde{\mathbb{C}} = \mathbb{C}_p = \mathbb{R}_p[i]$, $\tilde{\Omega} = \Omega \cap \tilde{\mathbb{C}}$ and assume that we have a program for computing a numeric approximation $\tilde{H}: \tilde{\Omega} \times \tilde{\mathbb{C}} \rightarrow \tilde{\mathbb{C}}^n$ of H . Given $z_1 \in \tilde{\Omega}$ with $\tilde{H}(z_1, 1) \approx 0$, we thus want to compute $z_0 \in \tilde{\Omega}$ with $\tilde{H}(z_0, 0) \approx 0$, by following the homotopy.

In many cases, we will be interested in homotopies for solving a system

$$P_1(z) = \dots = P_n(z) = 0 \quad (11)$$

of polynomial equations. The number d of solutions to a generic system of this kind is given by the Bezout number $d = d_1 \dots d_n$, where d_i is the total degree of P_i for each i . For suitable scaling parameters $\lambda_1, \dots, \lambda_n, \sigma_1, \dots, \sigma_n \in \mathbb{C}$, we now define $H: \mathbb{C}^{n+1} \rightarrow \mathbb{C}$ by

$$\begin{aligned} H_1(z, t) &= (1-t) P_1(z, t) + t \lambda_1 (z^{d_1} - \sigma_1^{d_1}) \\ &\vdots \\ H_n(z, t) &= (1-t) P_n(z, t) + t \lambda_n (z^{d_n} - \sigma_n^{d_n}). \end{aligned}$$

Let

$$K = \{0, \dots, d_1 - 1\} \times \dots \times \{0, \dots, d_n - 1\}$$

For any $k \in K$, the point

$$z_1^k = (\sigma_1 e^{2\pi i k_1/d_1}, \dots, \sigma_n e^{2\pi i k_n/d_n})$$

clearly satisfies $H(z_1^k) = 0$, whereas any z_0^k with $H(z_0^k, 0) = 0$ satisfies $P(z_0^k) = 0$.

If the system (11) is zero dimensional and the values $\lambda_1, \dots, \lambda_n, \sigma_1, \dots, \sigma_n$ are complex and sufficiently random (we also say that the homotopy is in general position), then the system $H_1(z, t) = \dots = H_n(z, t) = 0$ is also zero dimensional for every $t \in [0, 1]$. In what follows we will always assume that the homotopy has been chosen in such a way.

4.2. Solutions at infinity

One classical difficulty with homotopy methods for solving a polynomial system (11) is that many of the solution paths z_t^k may tend to infinity in the sense that $(z_t^k)_i \rightarrow \infty$ for some i and $t \rightarrow 0$. Computations which infinities can be avoided by rewriting the equations in projective coordinates. More precisely, setting $z^{\text{Pr}} = (z_0, \dots, z_n)$, the projectivisation $A^{\text{Pr}} \in \mathbb{C}[z^{\text{Pr}}]$ of a polynomial $A \in \mathbb{C}[z]$ is defined by

$$A^{\text{Pr}}(z_0, \dots, z_n) = z_0^{\deg A} A\left(\frac{z_1}{z_0}, \dots, \frac{z_n}{z_0}\right).$$

Applying this to the system (11), we obtain a new system

$$P_1^{\text{Pr}}(z^{\text{Pr}}) = \dots = P_n^{\text{Pr}}(z^{\text{Pr}}) = 0 \tag{12}$$

of homogeneous equations in z^{Pr} . For a random hyperplane

$$\alpha_0 z_0 + \dots + \alpha_n z_n = \beta, \tag{13}$$

the composite system (12–13) is again zero dimensional, but without solutions at infinity. It is easy to reconstruct solutions to (11) from solutions to (12–13) and *vice versa*.

4.3. Predictor corrector methods

Assume that we have a way to approximate the Jacobian J_H of H by $\tilde{J}_H: \tilde{\Omega} \rightarrow \tilde{\mathbb{C}}^{n \times (n+1)}$. For instance, if H is given by a dag, then a dag for J_H can be computed using forward differentiation, and \tilde{J}_H just corresponds to the approximated evaluation of this dag.

Assume that we are given $y = \tilde{H}(z, t)$ and $\tilde{J}_H(z, t)$ at a certain point where $\tilde{H}(z, t) \approx 0$. We may write $\tilde{J}_H(z, t) = (U, \dot{y})$ as the horizontal join of two matrices $U \in \tilde{\mathbb{C}}^{n \times n}$ and $\dot{y} \in \tilde{\mathbb{C}}^{n \times 1}$. Given $t' = t + d_t$ close to t , we may find a $z^{(1)}$ for which $\tilde{H}(z^{(1)}, t') \approx 0$ using Euler-Newton's method

$$z^{(1)} = z - U^{-1}(y + \dot{y}(t' - t)).$$

The replacement $(z, t) \rightsquigarrow (z^{(1)}, t')$ is called a *prediction* step. We may still apply the formula when $t' = t$, in which case z' is usually a better approximation than z to a genuine zero of H at t than z . In this situation, the replacement $(z, t) \rightsquigarrow (z^{(1)}, t)$ is called a *correction* step.

From the computational point of view, the evaluation of the Jacobian $J_{\tilde{H}}(z, t)$ is usually about n times more expensive than the evaluation of the function $\tilde{H}(z, t)$ itself (except for large n and sparse $J_{\tilde{H}}$). Instead of reevaluating the Jacobian after the prediction step at $(z^{(1)}, t')$, it may therefore be worth it to perform a few correction steps using the Jacobian at (z, t) instead:

$$\begin{aligned} z^{(2)} &= z^{(1)} - U^{-1} \tilde{H}(z^{(1)}, t') \\ &\vdots \\ z^{(\kappa)} &= z^{(\kappa-1)} - U^{-1} \tilde{H}(z^{(\kappa-1)}, t'). \end{aligned}$$

Since the convergence of $z^{(1)}, z^{(2)}, \dots$ is only linear, the number κ is typically chosen quite small ($\kappa \leq 3$). One full prediction-correction cyclis now just consists of the replacement $(z, t) \rightsquigarrow (z', t') = (z^{(\kappa)}, t')$.

From the complexity point of view, the evaluation of \tilde{H} and $J_{\tilde{H}}$ is usually far more expensive than the cost $\mathcal{O}(n^3)$ of linear algebra at size n , at least for the examples we will be interested in here. Therefore, it will not be necessary to device the linear algebra algorithms with special care (for instance, we may simply compute the inverse U^{-1} once and for all, instead of using LU decompositions). On the other hand, we typically want to increase the step size $t' - t$ as much as possible, while trying to stay reasonably close to the true solution path.

4.4. Precision control

One obvious source of numeric errors is when the numeric precision being used is insufficient for producing sensible results. In [BSHW08], a strategy has been proposed for selecting a sufficient precision for homotopy methods to be numerically reliable. We will now propose an alternative method for finding such a precision, whose justification is based on a simpler argument.

Let p be the current working precision. Our method is based on the following idea: when evaluating $y = \tilde{H}(z, t)$, the actual precision q of the result is usually smaller than p and of the form $q = p - c$ for some fixed constant. We will call q the *effective precision* and we may expect the numeric evaluations to be reliable as long as p is picked sufficiently large such that $q \geq \tau_0$ remains above a certain threshold $\tau_0 > 0$ (e.g. $\tau_0 = 10$).

We still need a more precise definition of the effective precision or a simple way to compute it. Assuming that \tilde{H} admits a ball lift, we may evaluate $\mathbf{y} = \tilde{H}(z, t)$ at the ball $(z, t) = (z + \mathcal{B}(0), t + \mathcal{B}(0)) \in \mathcal{B}(\mathbb{C}_p, \mathbb{R}_p)^{n+1}$. Then

$$q_{\text{rel}}(z, t) = \min_i \left[\log_2 \frac{|\text{cen}(\mathbf{y}_i)|}{\text{rad}(\mathbf{y}_i)} \right]$$

provides an estimate for the relative precision of \mathbf{y} . If $\tilde{H}(z, t) \approx 0$, then this precision is potentially quite low. In that case, we may also consider $q_{\text{rel}}(z, t')$ at the next time $t' = t + d_t$. Instead of performing one extra ball evaluation, we may also use the following approximation of $q_{\text{rel}}(z, t')$:

$$q_{\text{rel}}^*(z, t') = \min_i \left[\log_2 \frac{|\text{cen}(\mathbf{y}_i) + \tilde{H}_t(z, t)_i d_t|}{\text{rad}(\mathbf{y}_i)} \right].$$

We now take

$$q = q(z, t, t') = \min_i \left[\log_2 \frac{\max\{|\text{cen}(\mathbf{y}_i)|, |\text{cen}(\mathbf{y}_i) + \tilde{H}_t(z, t)_i d_t|\}}{\text{rad}(\mathbf{y}_i)} \right].$$

for the current effective precision at (z, t) and assuming a current step size d_t .

4.5. Step size control

Since purely numeric homotopy methods are usually being designed for speed, the main focus is not on being 100% fool proof. Nevertheless, it remains worth it to search for cheap ways in order to detect errors and adapt the stepsize so as to avoid potential errors.

Now assume that we perform one full prediction correction cyclis $(z, t) \rightsquigarrow (z', t')$. We first need a criterion for when to accept such a step. The main problem with the design of numeric criteria is there is no way to decide whether a numeric quantity is small or large; such checks can only be performed with respect to other quantities. Instead of checking whether we remain close to the genuine solution path, it is therefore more robust to check that the Jacobian \tilde{J}_H does not change too quickly on the interval $[t, t']$.

More precisely, let $y = \tilde{H}(z, t)$, $(U, \dot{y}) = \tilde{J}_H(z, t)$, $y' = \tilde{H}(z', t')$ and $(U', \dot{y}') = \tilde{J}_H(z', t')$. Then it is natural to only accept steps for which

$$\|U^{-1}U' - 1\| \leq \tau_1, \quad (14)$$

for a fixed threshold $\tau_1 < 1$ (e.g. $\tau_1 = \frac{1}{4}$). Here we may use any matrix norm $\|\cdot\|$, so it is most convenient to choose one which is easy to compute:

$$\|M\| = \sum_i \max_j |M_{i,j}|.$$

The condition (14) is not fully satisfactory yet, since it relies on the expensive computation of a Jacobian U' . This is acceptable if the step has a good chance of being accepted (since we will need the Jacobian anyway for the next step), but annoying if the step is to be rejected. Before checking (14), it is therefore wise to perform a few cheaper checks in order to increase the probability that (14) will hold indeed. In particular, if $\kappa \geq 2$, then we may verify that

$$\|U^{-1}(y' - y^{(1)}) - (z' - z^{(1)})\| \leq \tau_2 \|z' - z^{(1)}\| \quad (15)$$

for the max-norm on vectors, where $\tau_2 \leq \tau_1$ (e.g. $\tau_2 = \frac{1}{2} \tau_1$) and $y^{(1)} = \tilde{H}(z^{(1)}, t')$. This simplified check is linked to (14) by remarking that $y' - y^{(1)} \approx U'(z' - z)$. The new check (15) should not be applied when z' and $z^{(1)}$ are too close for y' and $y^{(1)}$ to be computed with sufficient precision. More precisely, it should really be replaced by the check

$$\begin{cases} \|U^{-1}(y' - y^{(1)}) - (z' - z^{(1)})\| \leq \tau_2 \|z' - z^{(1)}\| \vee \\ \|z' - z^{(1)}\| \leq 2^{-\tau_3 q(z, t, t')} \|z^{(1)}\|, \end{cases} \quad (16)$$

where τ_3 is slightly smaller than one (e.g. $\tau_3 = \frac{3}{4}$) and $q(z, t, t')$ stands for the “effective working precision” from section 4.4.

In addition to the above checks, one might wish to ensure that y' is reasonably small after each step. Unfortunately, there is no satisfactory reference with respect which smallness can be checked, except for $y^{(1)}, \dots, y^{(\kappa-1)}$. The best we can do therefore consists of checking whether $y^{(1)}, y^{(2)}, \dots$ tend to 0 at some indicated rate:

$$\begin{cases} \|y^{(i+1)}\| \leq \tau_4 \|y^{(i)}\| \vee \\ \|z^{(i+1)} - z^{(i)}\| \leq 2^{-\tau_4 q(z, t, t')} \|z^{(i)}\|, \end{cases} \quad (17)$$

for all $i < \kappa$, where $\tau_4 < 1$ (e.g. $\tau_4 = \frac{1}{2}$). Again, we need to insert a safety exemption for the case when the convergence is exceptionally good.

Once that we have a criterion on whether a step $(z, t) \rightsquigarrow (z', t')$ should be accepted, an algorithm for automatic stepsize control is easily implemented: assuming that we are walking from $t = 1$ to $t = 0$, we start by setting $d_t := -1$. Given t and d_t , we try a step $(z, t) \rightsquigarrow (z', t')$ until $t' := t + d_t$. If the step fails, then we set $d_t := \lambda_{\text{fail}} d_t$ with $\lambda_{\text{fail}} < 1$ (e.g. $\lambda_{\text{fail}} = \frac{1}{2}$), and retry for the smaller stepsize. Otherwise, we accept the step $t := t'$ and set $d_t := \lambda_{\text{ok}} d_t$ for the next step, where $\lambda_{\text{ok}} > 1$ (e.g. $\lambda_{\text{ok}} = \sqrt{2}$).

4.6. Near collisions

Another way to look at the numerical error problem is to investigate what can actually go wrong. Theoretically speaking, around each true solution path z_t , there exists a small tube T_t of variable polyradius r_t , where Newton’s method converges to the true solution z_t . As long as our current approximation z at time t remains in this tube T_t , no errors will occur. Now the Newton iterations have a strong tendency of projecting back into the tubes, especially if we use the additional safeguard (17). Nevertheless, it might happen that we jump from one tube into another tube, whenever two solution paths come close together.

If we are considering a homotopy for solving a polynomial system $P_1 = \dots = P_n$, then various solution paths will actually meet at $t=0$ if the system admits multiple roots. Such multiple roots are an intrinsic difficulty and we will need dedicated “end game” strategies to ensure good numeric convergence in this case (see section 5 below).

For $t > 0$, and for suitably prepared functions H , the Lebesgue probability that two solutions paths meet at a point is zero. Nevertheless, we may have near collisions, which usually occur in pairs: the probability that more than two paths simultaneously pass close to a same point is extremely low.

So assume that we have a near collision of two solution paths. Then we have a true collision at (z_*, t_*) for some complex time t_* near the real axis. Locally around this collision point, the two paths are then given by

$$z_t^\pm = z_* \pm u \sqrt{t - t_*} + \mathcal{O}(t - t_*),$$

for some vector u . If we only know z_t^+ at a few points, then we may try to compute z_* , t_* and u , and also check whether the second path z_t^- indeed exists.

Now assume that we have approximated z_t^+ and derivative $\dot{z}_t^+ = dz_t^+/dt$ at two times $t_1 > t_2$. Denote these approximations by $\tilde{z}_1 = \tilde{z}_1^+ \approx z_{t_1}^+$, $\tilde{\dot{z}}_1 \approx \dot{z}_{t_1}^+$, $\tilde{z}_2 = \tilde{z}_2^+ \approx z_{t_2}^+$ and $\tilde{\dot{z}}_2 \approx \dot{z}_{t_2}^+$. Then

$$\tilde{\dot{z}}_i \approx \frac{u}{2\sqrt{t_i - t_*}}$$

for $i \in \{1, 2\}$, whence we may use the following approximations for z_* , t_* and u :

$$\begin{aligned} \tilde{t}_* &:= \frac{(\tilde{\dot{z}}_2)^2 t_2 - (\tilde{\dot{z}}_1)^2 t_1}{(\tilde{\dot{z}}_2)^2 - (\tilde{\dot{z}}_1)^2} \\ \tilde{u} &:= 2\tilde{\dot{z}}_2 \sqrt{t_2 - \tilde{t}_*} \\ \tilde{z}_* &:= \tilde{z}_2 - \tilde{u} \sqrt{t_2 - \tilde{t}_*}. \end{aligned}$$

We next perform several safety checks. First of all, we obtained \tilde{t}_* as the division of two vectors; we may use the mean value of the componentwise divisions and check that the variance remain small. We next verify that $\tilde{z}_1 - \tilde{u} \sqrt{t_1 - \tilde{t}_*}$ and \tilde{z}_* are reasonably close. We also verify that the Newton iteration starting at $\tilde{z}_2^- = \tilde{z}_* - u \sqrt{t_2 - \tilde{t}_*}$ converges to a solution close to \tilde{z}_2^- . We finally verify that the same thing holds for $\tilde{z}_2^\pm = \tilde{z}_* \pm u \sqrt{t_2 - \tilde{t}_*}$ instead of \tilde{z}_2^\pm , where $t_2 = \text{Re}(2\tilde{t}_* - t_2)$.

We will not go into technical details on the precise numerical checks here, since section 5.3 below contains a similar discussion for the case of multiple roots at $t=0$. We may also adapt the herd iteration from section 5.2 below to near collisions, which allows for the simultaneous continuation of z_t^+ and z_t^- . Contrary to the case when $t \rightarrow 0$, we also need to recompute better estimations of t_* at every step, which can be done *via* the simultaneous computation of z_t^\pm and the two “conjugate” paths $z_{\bar{t}}^\pm$ with $\bar{t} = \text{Re}(2\tilde{t}_* - t)$. Indeed, using the higher order expansion

$$z_t^\pm = z_* \pm u \sqrt{t - t_*} + v(t - t_*) + w(t - t_*)^{3/2} + \mathcal{O}((t - t_*)^2),$$

we get

$$\begin{aligned} z_t^+ + z_t^- &= 2z_* + 2v(t - t_*) + \mathcal{O}((t - t_*)^2) \\ z_{\bar{t}}^+ + z_{\bar{t}}^- &= 2z_* + 2v(\bar{t} - t_*) + \mathcal{O}((\bar{t} - t_*)^2) \\ \dot{z}_t^+ + \dot{z}_t^- &= 2v + \mathcal{O}(t - t_*), \end{aligned}$$

from which we may deduce high quality approximations of t^* and z^* . As soon as $\bar{t} - t$ is small with respect to $\text{Im } t_*$, then the junction between paths and their conjugates occurs and we know how to traverse the near collision.

5. MULTIPLE ROOTS

5.1. Straightforward Euler-Newton type methods

Consider a homotopy induced by a polynomial system (11) with a zero dimensional set of solutions. It frequently occurs that some of the solutions are multiple roots, in which case the predictor corrector algorithm slows down significantly when t approaches 0. This is due to the fact that Newton's method only has a linear convergence if we are approaching a multiple root, whereas the convergence is quadratic for single roots.

In order to get a better understanding of this phenomenon, it is instructive to quantify the slow down in the case of an r -fold root of a univariate polynomial P , which is more or less representative for the general case. In the neighbourhood of the root α , we have

$$P_{+\alpha}(z) := P(\alpha + z) = cz^r + \mathcal{O}(z^{r+1}),$$

with $c = \frac{1}{r!} P^{(r)}(\alpha)$. Hence, the Newton iteration becomes

$$\begin{aligned} z' &= z - \frac{P_{+\alpha}(z)}{P'_{+\alpha}(z)} \\ &= \left(1 - \frac{1}{r}\right)z + \mathcal{O}(z^2). \end{aligned}$$

In particular, we see that we need roughly r iterations in order to divide z by e . We also notice that $P(\alpha + z)$ is roughly divided by e at every iteration. For complexity measures, it is more reasonable to study the speed of convergence of $P(\alpha + z)$ rather than z itself. Indeed, the relative precision of an r -fold root is intrinsically r times smaller than the working precision.

If we are rather considering a homotopy $H(z, t) = (1 - t)P(z) + tQ(z)$, then we usually have $q = Q(\alpha) \neq 0$. Locally, we may thus write

$$H(\alpha + z, t) = cz^r + qt + \mathcal{O}(z^{r+1}) + \mathcal{O}(zt).$$

Assume that we have $H(\alpha + z, t) = 0$ for small z and $t > 0$, so that

$$z^r = -\frac{q}{c}t + \mathcal{O}(z^{r+1}).$$

Then the Euler-Newton iteration for step size d_t yields

$$\begin{aligned} z' &= z - \frac{q d_t}{r c z^{r-1}} \\ &= \left(1 - \frac{d_t}{r t}\right)z + \mathcal{O}(z^2). \end{aligned}$$

Following our criterion (14), we should have

$$\left| \left(1 - \frac{d_t}{r t}\right)^{r-1} - 1 \right| \leq \tau_1.$$

Roughly speaking, this means that $d_t \leq \tau_1 t$. Hence, t is multiplied by $1 - \tau_1$ at every step and z is multiplied by $1 - \tau_1$ every r steps.

5.2. The herd iteration

For high precision computations, it would be nice to have an algorithm with quadratic convergence in t . Before we give such an algorithm, let us first introduce some terminology and study the behaviour of the solutions paths when $t \rightarrow 0$.

By assumption, we are given a system (11) with an r -fold root $\alpha \in \Omega$. Consider a solution path z_t for the homotopy with $\lim_{t \rightarrow 0} z_t = \alpha$. Since z_t is algebraic in t , we may expand

$$z_t = \alpha + c_1 t^{1/p} + c_2 t^{2/p} + \dots,$$

as a Puiseux series in t for a certain ramification index p (which we assume to be taken minimal). Now letting t turn around 0 once, we have

$$z_{e^{2\pi i}t} = \alpha + c_1 \omega t^{1/p} + c_2 \omega^2 t^{2/p} + \dots,$$

where $\omega = e^{2\pi i/p}$. When turning repeatedly, we thus obtain p pairwise distinct solutions paths $z_t^k := z_{e^{2\pi i k}t}$ with $k \in \{0, \dots, p-1\}$. We will call such a family of solution paths a *herd*.

Contrary to the homotopy methods from section 4, which operate on individual paths, the iteration that we will present now simultaneously operates on all paths in a herd. Consider a solution path z_t with $\lim_{t \rightarrow 0} z_t = \alpha$ as above and the corresponding herd $z_t^k = z_{e^{2\pi i k}t}$ with $k \in \{0, \dots, p-1\}$. We assume that both $\tilde{z}_t^k \approx z_t^k$ and $\dot{\tilde{z}}_t^k \approx \dot{z}_t^k$ are known for a given $t > 0$ and all $k \in \{0, \dots, p-1\}$. Let (F_0, \dots, F_{p-1}) and $(\dot{F}_0, \dots, \dot{F}_{p-1})$ denote the FFT-transforms of the vectors $(\tilde{z}_t^0, \dots, \tilde{z}_t^{p-1})$ and $(\dot{\tilde{z}}_t^0, \dots, \dot{\tilde{z}}_t^{p-1})$ with respect to ω^{-1} . Then we have

$$\begin{aligned} F_k &= \sum_{i=0}^{k-1} \tilde{z}_t^i \omega^{-ik} \\ &= n t^{k/p} (c_k + c_{k+p} t + \mathcal{O}(t^2)) \\ t \dot{F}_k &= \frac{n}{p} t^{k/p} (k c_k + (k+p) c_{k+p} t + \mathcal{O}(t^2)). \end{aligned}$$

for all k . We now compute $\tilde{c}_0, \dots, \tilde{c}_{2p-1}$ using the formulas

$$\begin{aligned} \tilde{c}_{k+p} &:= \frac{1}{n t^{1+k/p}} \left(t \dot{F}_k - \frac{k}{p} F_k \right) \\ &= c_{k+p} + \mathcal{O}(t) \\ \tilde{c}_k &:= \frac{1}{n t^{k/p}} (F_k - \tilde{c}_{k+p} t) \\ &= c_k + \mathcal{O}(t^2). \end{aligned}$$

For $t' > 0$ of the order of t^2 , we now have

$$\begin{aligned} z_{t'}^k &= \tilde{z}_{t'}^k + \mathcal{O}(t^2) \\ \tilde{z}_{t'}^k &:= \tilde{c}_0 + \tilde{c}_1 \omega^k (t')^{1/p} + \dots + \tilde{c}_{2p-1} \omega^{(2p-1)k} (t')^{(2p-1)/p}, \end{aligned} \quad (18)$$

for all $k \in \{0, \dots, p-1\}$. We call (18) the *herd prediction*. This prediction may be corrected using κ conventional Newton iterations at time t' , for a fixed constant $\kappa \in \mathbb{N} \setminus \{0\}$. A complete cyclcus of this type will be called a *herd iteration*.

5.3. Step size control for herd iterations

Several technical details need to be settled in order to obtain a robust implementation of herd iterations. First of all, we need a numeric criterion for deciding when the approximations $\tilde{z}_t^k \approx z_t^k$ and $\dot{\tilde{z}}_t^k \approx \dot{z}_t^k$ are of a sufficient quality for starting our herd iteration. Clearly, the error of the approximation should be in $\mathcal{O}(t^2)$.

We may first ensure ourselves that the approximation can not substantially be improved using Newton iterations: let $(\tilde{z}_t^k)'$ be the result of applying one Newton iteration to \tilde{z}_t^k at time t . Then we check whether

$$\text{relerr}(\tilde{z}_t^k, (\tilde{z}_t^k)') := \frac{|\tilde{z}_t^k - (\tilde{z}_t^k)'|}{|\tilde{z}_t^k|} \leq \tau_5 t^2, \quad (19)$$

for some threshold τ_5 , such as $\tau_5 = \frac{1}{2}$ (although this check becomes unstable if $\tilde{z}_t^k \approx 0$, we notice that this situation cannot arise systematically for $t \rightarrow 0$).

The check (19) for $k \in \{0, \dots, p-1\}$ does not yet guarantee that the \tilde{z}_t^k correspond to approximate evaluations of the Puiseux expansions. In order to check that this is indeed the case, we first compute the \tilde{c}_k as described in the previous section. Defining

$$\tilde{c}(t) = \tilde{c}_0 + \tilde{c}_1 t^{1/p} + \dots + \tilde{c}_{2p-1} t^{(2p-1)/p},$$

we next evaluate $\tilde{z}_t^{k+1/2} = \tilde{c}(e^{2\pi i k + \pi i} t)$ for all $k \in \{0, \dots, p\}$ and apply one Newton iteration at time t to the results, yielding $(\tilde{z}_t^{k+1/2})'$. We now check whether

$$\text{relerr}(\tilde{z}_t^{k+1/2}, (\tilde{z}_t^{k+1/2})') \leq \tau_6 t^2, \quad (20)$$

for some threshold τ_6 , such as $\tau_6 = 1$, and all k . Of course, this second check is more expensive than the first check (19). The thresholds should therefore be adjusted in such a way that the second check is likely to succeed whenever the first one does.

The above criteria can also be used for deciding whether a proposed herd iteration from t to t' should be accepted or not. We still have to decide how to chose t' . For a fixed constant $\gamma > 1$ and a positive integer s which may change at every step, we will take

$$t' = 2^{-\gamma^s} t.$$

If a step is accepted, then we increase s by one or a larger integer smaller than $1/\log_2 \gamma$. If a step is not accepted, then we decrease s by one and repeat the same procedure until acceptance or $s = 0$. If $s = 0$, then we have either reached the best possible accuracy for the current working precision, or our p paths did not really converge to the same point α . The first case occurs whenever the effective precision from section 4.4 drops below a given threshold. In the latter case, we revert to individual homotopies for further continuation.

5.4. Detection of clusters

Let us now go back to the initial polynomial system (11) and assume that we have computed numerical approximations of all $d = d_1 \cdots d_n$ individual homotopies $(z_t^k)_{k \in K}$ up till a certain time $t > 0$. We need a way to partition the individual paths into herds. One obvious way is to follow all solution paths from t to $e^{2\pi i} t$ and deduce the corresponding permutation of K . However, this computation is quite expensive, so it would be nice to have something faster.

A first step towards the detection of herds is to find all clusters, i.e. all groups of paths which tend to the same limit α . Here we notice that one cluster may contain several herds, as in the example

$$\begin{aligned} x^2 &= t \\ y^2 &= t, \end{aligned}$$

where all four solution paths $(x_t, y_t) = (\epsilon_x \sqrt{t}, \epsilon_y \sqrt{t})$ with $\epsilon_x, \epsilon_y \in \{-1, 1\}$ tend to the quadruple root $(0, 0)$ of $x^2 = y^2 = 0$. This cluster contains two herds $(x_t, y_t) = (\pm\sqrt{t}, \pm\sqrt{t})$ and $(x_t, y_t) = (\pm\sqrt{t}, \mp\sqrt{t})$.

Now let $\tilde{z}_t^k \approx z_t^k$ and $\tilde{\tilde{z}}_t^k \approx \dot{z}_t^k$ for all $k \in K$. For each $k \in K$, we consider the ball

$$z_t^k = \tilde{z}_t^k + \mathcal{B}(2t \tilde{z}_t^k).$$

The radii of these balls has been chosen with care, such that, with high probability, any two paths which belong to the same herd are also in the same connected component of $\mathcal{Z} := \bigcup_{k \in K} z_t^k$. This is best verified on the case of path $z_t = \alpha + ct^{1/p} + \dots$. Then the next path in the cluster is $z_{e^{2\pi i}t} = \alpha + c\omega t^{1/p} + \dots$ and

$$\begin{aligned} \frac{1}{2} |z_{e^{2\pi i}t} - z_t| &\approx \frac{c}{2} |\omega - 1| t^{1/p} \\ &\leq \frac{2c}{p} t^{1/p} \\ &\approx 2t \dot{z}_t. \end{aligned}$$

An efficient way to separate different connected components of \mathcal{Z} is via projection. Let $\lambda \in \mathbb{R}^{2n}$ be a random vector of real numbers of length $\|\lambda\| = 1$. Then any point $z \in \mathbb{C}^n$ may be projected to the vector product $\pi_\lambda(z) = \lambda \cdot (\operatorname{Re} z, \operatorname{Im} z) \in \mathbb{R}$. Applying this projection to our balls z_t^k , we obtain intervals \mathbf{x}^k . We may sort the \mathbf{x}^k (and the corresponding z_t^k) on their centers in time $\mathcal{O}(d \log d)$ and compute the various connected components of $\mathcal{X} := \bigcup_{k \in K} \mathbf{x}^k$ using a linear pass. Whenever \mathbf{x}^k and \mathbf{x}^l are in different connected components, then so are z_t^k and z_t^l . Assuming that t is sufficiently small, application of this procedure for $2n$ random vectors λ results with probability one in the separation of all connected components corresponding to different clusters.

5.5. Detection of herds

Let $K' \subseteq K$ be a set of indices such that the z^k with $k \in K'$ form a cluster with limit α . We still need a way to find the various herds inside the cluster. In a similar way as in section 5.3, we may improve the quality of our approximations \tilde{z}^k and $\tilde{\tilde{z}}^k$ via Newton iteration until $\tilde{z}_t^k = z_t^k + \mathcal{O}(t^2)$ and $\tilde{\tilde{z}}_t^k = \dot{z}_t^k + \mathcal{O}(t)$. From now on, we assume that we have done this.

For each $k \in K'$ and $i \in \{1, \dots, n\}$, we may write

$$(z_t^k)_i = \alpha_i + c_i^k t^{\beta_i^k} + \dots,$$

for some $c_i^k \in \mathbb{C} \setminus \{0\}$ and $\beta_i^k \in \mathbb{Q}^>$. We obtain a good approximation $A \approx \alpha + \mathcal{O}(t)$ using

$$\tilde{\alpha} = \frac{1}{|K'|} \sum_{k \in K'} \tilde{z}_t^k. \quad (21)$$

If $|K'|$ is not too large (so that β_i^k has a small numerator and denominator), then we also obtain reasonably accurate approximations $\tilde{\beta}_i^k \approx \beta_i^k$ and $\tilde{c}_i^k \approx c_i^k$ by

$$\begin{aligned} \tilde{\beta}_i^k &= \frac{t (\tilde{\tilde{z}}_t^k)_i}{(\tilde{z}_t^k)_i - \alpha_i} \\ \tilde{c}_i^k &= (\tilde{z}_t^k - \alpha) t^{-\tilde{\beta}_i^k}. \end{aligned}$$

and check whether

$$z_{e^{2\pi i}t}^k \approx \tilde{\alpha} + \tilde{c}^k e^{2\pi i \tilde{\beta}_i^k} t^{\tilde{\beta}_i^k}$$

is indeed close to some $\tilde{z}^{k'}$ with $k' \in K'$. Doing this for all $k \in K'$, we thus obtain a candidate permutation $\sigma: K' \rightarrow K'$ with $z_{e^{2\pi i}t}^k = z_t^{\sigma(k)}$ for all $k \in K'$. Each cycle in this permutation induces a candidate herd. Using the criteria from 5.3, we may next check whether the quality of the candidate herd is sufficient. If not, then we may always resort to the more expensive computation of the solution path from t to $e^{2\pi i}t$.

5.6. Synchronization

Our algorithms for the previous sections for cluster and herd detection rely on the availability of approximations $\tilde{z}_t^k \approx z_t^k$ on all paths at the *same* time t . Usually the individual homotopies are launched in parallel and advance at different speeds. Consequently, the synchronization of all paths at the same time t is a non trivial matter.

Strictly speaking, we notice that it is not necessary to synchronize all paths, but rather those paths which belong to the same cluster or herd. In particular, we will concentrate on those paths which tend to multiple roots.

So consider a path z_t^k which tends to a multiple root α . As long as z_t^k is approximated using an individual continuation, we have seen that the convergence to $t \rightarrow 0$ is linear. For a fixed $\gamma < 1$ (such as $\gamma = \frac{1}{2}$), the computation of z_t^k at all ‘‘checkpoints’’ $t = \gamma, \gamma^2, \gamma^3, \dots$ thus only requires a constant overhead. At every checkpoint, we may now launch the algorithm for the detection of clusters. For every candidate cluster K' , we next determine the checkpoint γ^i with highest i at which $z_{\gamma^i}^k$ is available for all $k \in K'$. We launch our algorithm for the detection of herds at this checkpoint $t = \gamma^i$.

In addition, it is a good practice to check that we still have points on all $d = d_1 \cdots d_n$ paths at every checkpoint. For paths z_t^k which tend to a single root, we may approximate $z_{\gamma^i}^k$ for large i using a single step continuation from $t = 0$ to $t = \gamma^i$. For the approximation of α using (21), we notice that it is important that no paths of the cluster are missing or counted twice. Indeed, in the contrary case, we only have $A = \alpha + \mathcal{O}(t^\beta)$ with $\beta_i = \min_{k \in K'} \beta_i^k$ for all i , which is insufficient for the computation of accurate approximations of β_i^k and c_i^k .

6. CERTIFIED HOMOTOPIES

6.1. Certification of Newton’s method

Consider an analytic function $f: \Omega \rightarrow \mathbb{C}^n$ on some open subset Ω of \mathbb{C}^n and assume that f admits a ball lift. Given an isolated root z of f , it is well known that Newton’s method converges to z in a small neighbourhood of z . It is a natural question to explicitly compute a ball neighbourhood for which this is the case. One method which is both efficient and quite tight was proposed by Krawczyk [Kra69]. Recall that J_f denotes the Jacobian of f .

THEOREM 4. *Let $\mathbf{u} \in \mathbb{C}^n$ and let $g: \mathbf{u} \rightarrow \mathbb{C}^n$ be an analytic function. Let $g(\mathbf{u}) \in \mathbb{C}^n$ and $J_g(\mathbf{u}) \in \mathbb{C}^{n \times n}$ be ball enclosures of the sets $\text{im } g$ and $\text{im } J_g$. If*

$$g(\mathbf{u}) - J_g(\mathbf{u}) \mathcal{B}(\text{rad } \mathbf{u}) \subseteq \mathbf{u},$$

then g admits a fixed point $z \in \mathbf{u}$.

Proof. Let $u = \text{cen } \mathbf{u}$. For any $z \in \mathbf{u}$, we have

$$g(z) = g(u) + \int_0^1 J_g(u + (z - u)t) (z - u) dt.$$

Since $J_g(\mathbf{u})$ is convex, we also have

$$\int_0^1 J_g(u + (z - u)t) dt \in J_g(\mathbf{u}).$$

Hence

$$\begin{aligned} g(z) &\in g(u) + J_g(\mathbf{u}) (\mathbf{u} - u) \\ &\subseteq \mathbf{u}. \end{aligned}$$

It follows that g is an analytic function from the compact ball \mathbf{u} into itself. By Brouwer’s fixed point theorem, we conclude that there exists a $z \in \mathbf{u}$ with $g(z) = z$. \square

COROLLARY 5. Let $\mathbf{u} \in \mathbb{C}^n$ and let $V \in \mathbb{C}^{n \times n}$ be an invertible matrix with $VJ_f(\text{cen } \mathbf{u}) \approx 1$. If $\Omega \supseteq \mathbf{u}$ and

$$\mathbf{u} - Vf(\mathbf{u}) + (1 - VJ_f(\mathbf{u}))\mathcal{B}(\text{rad } \mathbf{u}) \subseteq \mathbf{u},$$

then the equation $f(z) = 0$ admits a root $z \in \mathbf{u}$.

Proof. We apply the theorem for $g(z) = z - Vf(z)$. \square

The above method is still a bit unsatisfactory in the sense that it does not guarantee the uniqueness of the solution. Denoting by $\text{int}(X)$ the interior of a subset X of \mathbb{R}^n , the following sharpening of the method is due to Rump [Rum80].

THEOREM 6. With the notations from theorem 4, if

$$g(\mathbf{u}) - J_g(\mathbf{u})\mathcal{B}(\text{rad } \mathbf{u}) \subseteq \text{int}(\mathbf{u}),$$

then g admits a unique fixed point in \mathbf{u} .

Proof. Let us first show that the spectral norm (i.e. the norm of the largest eigenvalue) of any $M \in J_g(\mathbf{u})$ is < 1 . Indeed, our assumption implies

$$\text{rad}(J_g(\mathbf{u})\mathcal{B}(\text{rad } \mathbf{u})) < \text{rad } \mathbf{u}.$$

Now consider the norm $\|v\| = \max(|v_1|/\text{rad } \mathbf{u}_1, \dots, |v_n|/\text{rad } \mathbf{u}_n)$ on \mathbb{C}^n . Then, for any $M \in J_g(\mathbf{u})$ and v with $\|v\| = 1$, we have

$$\begin{aligned} |Mv| &\leq \text{rad}(M\mathcal{B}(|v|)) \\ &\leq \text{rad}(M\mathcal{B}(\text{rad } \mathbf{u})) \\ &\leq \text{rad}(J_g(\mathbf{u})\mathcal{B}(\text{rad } \mathbf{u})) \\ &< \text{rad } \mathbf{u}, \end{aligned}$$

whence $\|Mv\| < 1$. This is only possible if the spectral norm of M is < 1 .

Now consider $\varphi(z) = z - g(z)$. By what precedes, any matrix M in $J_\varphi(\mathbf{u}) = 1 - J_g(\mathbf{u})$ is invertible. For any two distinct points $z, z' \in \mathbf{u}$, we have

$$\varphi(z') - \varphi(z) = \int_0^1 J_\varphi(z + (z' - z)t)(z' - z) dt.$$

Since $J_\varphi(\mathbf{u})$ is convex, there exists a matrix $M \in J_\varphi(\mathbf{u})$ with

$$M = \int_0^1 J_\varphi(z + (z' - z)t) dt.$$

By what precedes, it follows that $\varphi(z') - \varphi(z) = M(z' - z) \neq 0$. We conclude that $g(z) \neq z$ or $g(z') \neq z'$. The existence of a fixed point follows from theorem 4. \square

COROLLARY 7. With the notations of corollary 5, if

$$\mathbf{u} - Vf(\mathbf{u}) + (1 - VJ_f(\mathbf{u}))\mathcal{B}(\text{rad } \mathbf{u}) \subseteq \text{int}(\mathbf{u}),$$

then the equation $f(z) = 0$ admits a unique root $z \in \mathbf{u}$.

Proof. Application of theorem 6 for $g(z) = z - Vf(z)$. \square

Assuming that we have computed a numeric approximation \tilde{z} to a root z of f , a second question is how to find a suitable ball $\mathbf{z} \ni \tilde{z}$ for which the corollaries apply. Starting with $\mathbf{z}_0 := \tilde{z} + \mathcal{B}(0)$, a simple solution is consider the sequence defined by

$$\begin{aligned} \mathbf{z}_{i+1} &= \text{cen } \mathbf{z}_i + \mathcal{B}(\max(\text{rad } \mathbf{z}_i, \text{rad}(K(\mathbf{z}_i) - \text{cen } \mathbf{z}_i))) \\ &\supseteq \mathbf{z}_i \cup K(\mathbf{z}_i), \end{aligned} \tag{22}$$

where

$$K(\mathbf{u}) = \mathbf{u} - Vf(\mathbf{u}) + (1 - VJ_f(\mathbf{u}))\mathcal{B}(\text{rad } \mathbf{u})$$

Whenever $K(\mathbf{z}_i) \subseteq \text{int}(\mathbf{z}_i)$, then we are done. In order to ensure the convergence of this method, we need to tweak the recurrence (22) and replace it by

$$\mathbf{z}_{i+1} = \text{cen } \mathbf{z}_i + \mathcal{B}((1 + \varepsilon) \max(\text{rad } \mathbf{z}_i, \text{rad}(K(\mathbf{z}_i) - \text{cen } \mathbf{z}_i)) + \eta), \quad (23)$$

for suitable small positive constants ε and η . We refer to [Rum80] for more details on this technique, which is called ε -inflation.

6.2. Certification of a numeric homotopy continuation

Assume that the polynomial system (11) admits only simple roots and that we have obtained numeric approximations $\tilde{z}^k = \tilde{z}_0^k$ for all these roots using a numeric path tracker. Then theorem 5 suffices for the joint certification of the numeric approximations $\{\tilde{z}^k\}_{k \in K}$. Indeed, using the above technique, we first compute balls $\mathbf{z}^k \ni \tilde{z}^k$ for which theorem 5 applies. To conclude, it then suffices to check that these balls are pairwise disjoint. This can be done using the same algorithm as for the detection of clusters, which was described in section 5.4.

In the case when two balls \mathbf{z}^k and $\mathbf{z}^{k'}$ do intersect, then we recompute approximations for the paths z_t^k and $z_t^{k'}$ using a smaller step size, that is, by lowering the constant τ_1 in (14). We keep doing so until none of the balls \mathbf{z}^k intersect; even if some of the *paths* z_t^k may have been permuted due to numerical errors, the final *set* of all \mathbf{z}^k is correct if none of the balls intersect. Indeed, each of the balls contains a solution and there can be no more solutions than the number predicted by the Bezout bound.

If \mathbf{z}^k and $\mathbf{z}^{k'}$ intersect then, instead of recomputing the paths z_t^k and $z_t^{k'}$ using smaller and smaller step sizes, we may also search for a way to certify the entire homotopy computations. This will be the topic of the remainder of this section. Let us first show how to adapt the theory from the previous section to certified path tracking. From now on, we assume that $H: \Omega \times \mathbb{C} \rightarrow \mathbb{C}^n$ is an analytic function which admits a ball lift.

THEOREM 8. *Let $(\mathbf{u}, \mathbf{t}) \in \mathbb{C}^n \times \mathbb{C}$ be such that $\mathbf{u} \subseteq \Omega$. Let $J = (\partial H / \partial z)(\text{cen } \mathbf{u}, \text{cen } \mathbf{t})$ and let $V \in \mathbb{C}^{n \times n}$ be an invertible matrix with $VJ \approx 1$. If*

$$\mathbf{u} - VH(\mathbf{u}, \mathbf{t}) + (1 - V \frac{\partial H}{\partial z}(\mathbf{u}, \mathbf{t}))\mathcal{B}(\text{rad } \mathbf{u}) \subseteq \text{int}(\mathbf{u}),$$

then the equation $H(z, t) = 0$ admits a unique root $z \in \mathbf{u}$ for each $t \in \mathbf{t}$.

Proof. Let $t \in \mathbf{t}$ and consider the function $g: \mathbf{u} \rightarrow \mathbb{C}^n; z \mapsto z - H(z, t)$. Then $\mathbf{u} - VH(\mathbf{u}, \mathbf{t})$ encloses $\text{im } g$ and $1 - V \frac{\partial H}{\partial z}(\mathbf{u}, \mathbf{t})$ encloses $\text{im } J_g$, and we conclude by theorem 6. \square

Clearly, for any $t, t' \in \mathbf{t}$, theorem 8 ensures the existence of a unique solution path from t to t' in the tube $\mathbf{u} \times [t, t']$. As at the end of the previous section, the question again arises how to compute balls \mathbf{u} and \mathbf{t} for which the conditions of the theorem are likely to be satisfied. Since the computation of $\frac{\partial H}{\partial z}(\mathbf{u}, \mathbf{t})$ is expensive, it is important to keep down the number of iterations of the type (22) or (23) as much as possible (say at most one iteration).

Now assume that we performed a numeric homotopy computation from (z, t) to (z', t') . Then a reasonable first guess is to take

$$\begin{aligned} \mathbf{u} &= \frac{1}{2}(z + z') + \mathcal{B}(c(z' - z)) \\ \mathbf{t} &= \frac{1}{2}(t + t') + \mathcal{B}(\frac{1}{2}(t' - t)), \end{aligned}$$

for some $c > 1/2$, say $c = 1$. Unfortunately, if one of the components of $z' - z$ tends to zero, then this guess turns out to be inadequate. Therefore, it is recommended to use an additional inflation proportional to the norm of $z' - z$:

$$\mathbf{u} = 1/2(z + z') + \mathcal{B}(c(z' - z) + c'\|z' - z\|),$$

for some small $c' > 0$, say $c' = 1/10$. Another idea is to use the radius of the previous step as a reference (except for the very first step, of course). For instance, if our previous step went from (z, t) to (z', t') , then we may take

$$\mathbf{u} = 1/2(z + z') + \mathcal{B}(c(z' - z) + c''(z - z') \frac{t' - t}{t - t'}),$$

for some small $c'' > 0$, say $c'' = 1/10$.

6.3. Certification *via* tubular models

One important disadvantage of the method from the previous section for the certification of one path tracking step is that we use global error bounds on the tube $\mathbf{u} \times \mathbf{t}$. Consequently, the inaccuracy $\text{rad } \mathbf{u}$ of \mathbf{u} is proportional to the step size $2 \text{rad } \mathbf{t}$, whence any overestimation in the evaluation of H or J_H due to the inaccuracy in \mathbf{u} requires a reduction of the step size.

For this reason, it is much better to follow the solution path as closely as possible instead of enclosing it in a “square tube”. This can be achieved *via* the use of Taylor models. Using \mathcal{D} -stable Taylor models, it is possible to simultaneously compute of accurate enclosures for H and J_H on the tube.

More precisely, let $r_\epsilon \in (\mathbb{R}^>)^n$, $r_\delta \in \mathbb{R}^{\geq}$ and $D = \mathcal{B}(r_\epsilon) \times \mathcal{B}(r_\delta)$. For a fixed k in $\mathbb{N} \setminus \{0\}$, let $\mathcal{I} = \mathcal{J}$ be an initial segment of \mathbb{N}^{n+1} of the form

$$\mathcal{I} = 0 \times \{0, \dots, k\} \cup \{e_1, \dots, e_n\} \times \{0\}$$

and let $\mathcal{D} = \mathcal{T}_1 = \{i \in \mathbb{N}^{n+1} : \|i\| \leq 1\}$. A \mathcal{D} -stable Taylor model in $\mathcal{B}_D(\mathbb{C}[\epsilon, \delta]_{\mathcal{I}}, \mathbb{R}[\epsilon, \delta]_{\mathcal{I}})$ will also be called a *tubular model*. We will write $\mathbb{T}_{D, \mathcal{I}}$ for the set of tubular models. Given $\mathbf{y} \in \mathbb{T}_{D, \mathcal{I}}^n$, we let $\mathbf{y}_{\text{cst}} \in \mathbb{C}^n$ and $\mathbf{y}_{\text{lin}} \in \mathbb{C}^{n \times n}$ be such that

$$\begin{aligned} (\mathbf{y}_{\text{cst}})_i &= \varpi(\mathbf{y}_i) \\ (\mathbf{y}_{\text{lin}})_{i,j} &= \varpi\left(\frac{\partial \mathbf{y}_i}{\partial \epsilon_j}\right), \end{aligned}$$

for all $i, j \in \{1, \dots, n\}$.

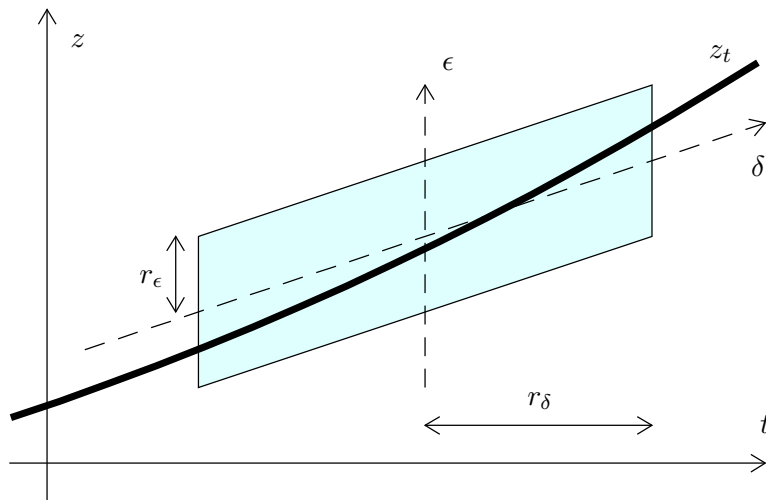

Figure 1. Illustration of a solution path z_t in a tube.

THEOREM 9. *Let $c = (c_\epsilon, c_\delta) \in \Omega \times \mathbb{C}$, $r = (r_\epsilon, r_\delta) \in (\mathbb{R}^>)^n \times \mathbb{R}^>$, $D = \mathcal{B}(r)$ and let*

$$Z(\delta) = Z_0 + \dots + Z_{k_1} \delta^{k_1}$$

be an approximation of the solution $z_{c_\delta + \delta}$ to $H(z_{c_\delta + \delta}, c_\delta + \delta) = 0$. For instance, if $k = 1$ and $H(c) \approx 0$, then we may take $Z(\delta) \approx -VF\delta$, with $V \approx (\partial H / \partial z)(c)^{-1}$ and $F \approx (\partial H / \partial t)(c)$. Consider $\mathbf{u} \in \mathbb{T}_{D, \mathcal{I}}^n$ and $\mathbf{t} \in \mathbb{T}_{D, \mathcal{I}}$ with

$$\begin{aligned} \mathbf{u}_i &= (c_\epsilon)_i + \epsilon_i + Z(\delta)_i \\ \mathbf{v} &= c_\delta + \delta. \end{aligned}$$

Let $g(z, t) = z - VH(z, t)$, $\mathbf{y} = g(\mathbf{u}, \mathbf{v}) - VZ(\delta)$. If

$$\mathbf{y}_{\text{cst}} + \mathbf{y}_{\text{lin}} \mathcal{B}(r_\epsilon) \subseteq \text{int}(c_\epsilon + \mathcal{B}(r_\epsilon)), \quad (24)$$

then the equation $H(z, t) = 0$ admits a unique solution $z \in c_\epsilon + Z(t - c_\delta) + \mathcal{B}(r_\epsilon)$, for every $t \in c_\delta + \mathcal{B}(r_\delta)$.

Proof. For an illustration of the proof, see figure 1. Let $u = \text{cen}(\mathbf{u}) \in \mathbb{C}[\epsilon, \delta]^n$ and $v = \text{cen}(\mathbf{v}) \in \mathbb{C}[\delta]$. By construction, and using the facts that $\partial u / \partial \epsilon = 1$ and $\partial v / \partial \epsilon = \partial Z / \partial \epsilon = 0$, we have

$$\begin{aligned} g(u(\epsilon, \delta), v(\delta)) - VZ(\delta) &\in \mathbf{y}_{\text{cst}} \\ \frac{\partial g}{\partial u}(u(\epsilon, \delta), v(\delta)) &\in \mathbf{y}_{\text{lin}} \end{aligned}$$

for any $\epsilon \in \mathcal{B}(r_\epsilon)$ and $\delta \in \mathcal{B}(r_\delta)$. For a fixed $t \in c_\delta + \mathcal{B}(r_\delta)$, it follows that \mathbf{y}_{cst} and \mathbf{y}_{lin} provide enclosures for $g(\cdot, t) - VZ(t - c_\delta)$ and $(\partial g / \partial u)(\cdot, t)$ on the disk $\mathcal{U} := c_\epsilon + Z(t - c_\delta) + \mathcal{B}(r_\epsilon)$. Consequently, $\mathbf{y}_{\text{cst}} + VZ(t - c_\delta)$ and \mathbf{y}_{lin} provide ball enclosures for $g(\cdot, t)$ and $(\partial g / \partial u)(\cdot, t)$ on \mathcal{U} , and our hypothesis (24) implies that

$$\mathbf{y}_{\text{cst}} + VZ(t - c_\delta) + \mathbf{y}_{\text{lin}} \mathcal{B}(r_\epsilon) \subseteq \text{int}(\mathcal{U}).$$

From corollary 6, we conclude that $g(\cdot, t)$ admits a unique fixed point $z \in \mathcal{U}$. \square

In order to apply the theorem, it remains to be shown how to find a good tube, i.e. how to choose c_ϵ , c_δ , r_ϵ , r_δ and $Z(\delta)$. For a fixed order k of the approximation, the idea is to adjust c_ϵ and $Z(\delta)$ such that r_ϵ can be chosen minimal.

Let us first consider the first order case $k = 1$. Assume that we performed a numeric path continuation from (z_t, t) to $(z_{t'}, t')$ and that both \dot{z}_t and $\dot{z}_{t'}$ are approximatively known. Then there exists a unique curve \tilde{z}_s of degree three with $\tilde{z}_t = z_t$, $\tilde{z}_{t'} = z_{t'}$, $\dot{\tilde{z}}_t = \dot{z}_t$ and $\dot{\tilde{z}}_{t'} = \dot{z}_{t'}$. Let $\tilde{\tilde{z}}_s$ be a linear curve which minimizes the maximum μ_i of $|(\tilde{z}_s - \tilde{\tilde{z}}_s)_i|$ on $[t, t']$ for every i . Then we take $c_\delta = (t + t')/2$, $r_\delta = (t' - t)/2$, $c_\epsilon = \hat{z}_{c_t}$ and $Z(\delta) = \tilde{\tilde{z}}_{c_t} \delta$. We may also take $r_\epsilon = c \mu$ for some fixed $c > 1$ such as $c = 2$. However, for better performance it is recommended to apply an additional inflation to r_ϵ , similar to what we did in the previous section.

For higher orders k , we proceed in an essentially similar way. We first compute a high order numeric polynomial approximation \tilde{z}_s of z_s . For orders > 3 , this may require the accurate approximation of additional points $(z_{t''}, t'')$ with $t'' \in (t, t')$ on the solution path. We next find a k -th order polynomial \hat{z}_s which approximates \tilde{z}_s as good as possible and choose our tube in a similar way as above. It should be noticed that the evaluation $g(\mathbf{u}, \mathbf{v})$ in theorem 9 is at least thrice as expensive as the numeric evaluation of J_H . This makes it worth it to improve the quality of the numeric approximations of points $z_t, z_{t'}, z_{t''}$ on the curve using one or more additional Newton iterations. The use of higher order approximations makes it possible to choose r_ϵ very small, thereby avoiding a great deal of the overestimation due to the use of ball arithmetic.

7. CERTIFICATION OF MULTIPLE ROOTS

7.1. The univariate case

In section 5.1, we have studied in detail the numeric determination of a multiple root of a univariate polynomial. It is instructive to take up this study and examine how we certify such multiple roots. Since the property of being an r -fold root is lost under small perturbations, this is actually impossible using ball arithmetic. The best we can hope for is to certify the existence of r roots in a small ball, or the existence of an r -fold root of a small perturbation of the polynomial (see also [Rum10]). In this section we adopt the first point of view; a variant of the approach to perturb the polynomial itself will be studied in the next sections.

So consider a polynomial P with an approximate r -fold root at $c \in \mathbb{C}$ and assume that we wish to certify that P admits exactly r roots in the ball $c + \mathcal{B}(\rho)$, for some $\rho > 0$. One first strategy is to make use of the Taylor series expansion of P at c . More precisely, let $\mathbb{T} = \mathbb{T}_{D, \mathcal{I}, \mathcal{I}}$ be the set of univariate Taylor models in ϵ with $D = \mathcal{B}(\rho)$ and $\mathcal{I} = \{0, \dots, s\}$ for some $s \geq r$. Evaluating P at $\mathbf{c} = c + \epsilon$, we obtain a Taylor model $\mathbf{Q} = P(\mathbf{c})$ with the property that $P(c+z) \in \mathbf{Q}_0 + \dots + \mathbf{Q}_s z^s$ for any $z \in \mathcal{B}(\rho)$. It remains to be shown that any $Q \in \mathbf{Q}$ admits r roots in $\mathcal{B}(\rho)$. We claim that this is the case if

$$[\mathbf{Q}_0 + \dots + \mathbf{Q}_{r-1} \mathcal{B}(\rho)^{r-1} + \mathbf{Q}_{r+1} \mathcal{B}(\rho)^{r+1} + \dots + \mathbf{Q}_s \mathcal{B}(\rho)^s] < [\mathbf{Q}_r \mathcal{B}(\rho)^r]. \quad (25)$$

Indeed, assume that we have (25) and let $Q \in \mathbf{Q}$. Then

$$|Q(z) - Q_r z^r| < |Q_r z^r|$$

for all z with $|z| = \rho$. By Rouché's theorem, it follows that $Q(z)$ and $Q_r z^r$ admit the same number of roots on $\mathcal{B}(\rho)$. If r becomes large, or if P admits other roots close to $\mathcal{B}(\rho)$, then the bound (25) often does not hold. In that case, one may use more sophisticated techniques from [Sch82, vdH11] in order to certify that \mathbf{Q} admits r roots in $\mathcal{B}(\rho)$. From the complexity point of view, the series expansion method requires $\mathcal{O}(M(r))$ evaluations of P , where $M(r)$ denotes the cost of multiplying two polynomials of degrees $\leq r$.

Another approach is to apply Rouché's theorem in a more direct way by computing P on a path γ starting at ρ and which circles around the origin once. If the reliable image $P \circ \gamma$ of this path avoids the origin, then the number of roots of P coincides with the number of times that $P \circ \gamma$ turns around the origin. More precisely, let $\omega = e^{2\pi i/R}$ for a suitable $R > r$ (see also below) and let $\mathbf{z}_i = \omega^i + \mathcal{B}(|\sqrt{\omega} - 1|)$ for $i \in \{0, \dots, R-1\}$. Then we evaluate $\mathbf{y}_i = P(\mathbf{z}_i)$ and check whether $0 \notin \mathbf{y}_i$ for all i . If this is the case, then

$$r' = \frac{1}{2\pi} \sum_{i=0}^{R-1} \arg \frac{\text{cen}(\mathbf{y}_{i+1 \bmod R})}{\text{cen}(\mathbf{y}_i)}$$

yields the exact number of roots of P inside $\mathcal{B}(\rho)$. This method requires R evaluations of P , but R needs to be sufficiently large if we want to ensure a reasonable chance of success for the method.

Let us investigate the choice of an appropriate R in more detail on the simplest example when $c = 1$ and

$$P(z) = z^r - r z^{r-1} + \binom{r}{2} z^{r-2} + \dots + (-1)^r.$$

Consider the evaluation of P at $z = 1 + \rho + \mathcal{B}(\epsilon)$. We have

$$\begin{aligned} P(z) &= P(1 + \rho) + \mathcal{B}(\sigma) \\ &= \rho^r + \mathcal{B}(\sigma) \\ \sigma &= \sum_{k=0}^r \binom{r}{k} ((1 + \rho + \epsilon)^k - (1 + \rho)^k) \\ &= (2 + \rho + \epsilon)^r - (2 + \rho)^r \end{aligned}$$

For small ϵ , the condition $0 \notin P(z)$ thus implies

$$r(2 + \rho)^{r-1} \epsilon \approx (2 + \rho + \epsilon)^r - (2 + \rho)^r < \rho^r.$$

Roughly speaking, for $\rho \rightarrow 0$, this means that

$$\begin{aligned} \epsilon &< \frac{1}{r} \left(\frac{\rho}{2}\right)^{r-1} \rho \\ R &> \frac{\rho}{\pi \epsilon} > r \left(\frac{2}{\rho}\right)^{r-1}. \end{aligned}$$

We recall from example 2 that $(\rho/2)^{r-1}$ also corresponds to the punctual overestimation of the ball evaluation of P at $1 + \rho$. If we want to reduce R to a quantity which does not depend on ρ , then it follows from the considerations in section 3.5 that we need to evaluate P using Taylor models of order at least r . However, in that case, we might just as well use the first method based on a direct series expansion of P at c .

7.2. Certification of herd homotopies

Let us now consider a more general system (11) and assume that we are given a herd of solution paths z_t^1, \dots, z_t^r which all tend (at least approximately) to the same limit α . Instead of viewing the z_t^i as distinct individual paths, we would like to consider the whole herd $t \mapsto \mathcal{Z}_t = \{z_t^1, \dots, z_t^r\}$ as a single multivalued path.

From the algebraic point of view, it is more convenient to rather consider the ideal \mathfrak{J}_t which annihilates \mathcal{Z}_t instead of \mathcal{Z}_t itself. There are several ways to represent this ideal \mathfrak{J}_t by a system Σ_t of polynomial equations. One option is to require that Σ_t be a reduced Gröbner basis for \mathfrak{J}_t . Another option is to use Kronecker representations. Since we are computing with balls of a fixed bit precision, coefficient growth is not a problem, so it best to choose a simple representation which minimizes the number of coefficient parameters.

Now recall that each z_t^i can be considered as a vector $z_t^i = (z_{t,1}^i, \dots, z_{t,n}^i)$ of Puiseux series $z_{t,j}^i$ in t of valuations ≥ 0 . Setting

$$A_t(z_1) = (z_i - z_{t,1}^1) \cdots (z_i - z_{t,1}^r),$$

we notice that $A_t(z_1)$ is invariant if we turn t once around the origin. This means that $A_t(z_1)$ is really an analytic function in t at the origin. Assuming general position, $A_t(z_1)$ is actually the minimal annihilator of $\{z_{t,1}^1, \dots, z_{t,1}^r\}$. In what follows, we will represent \mathfrak{J}_t by the system of polynomials

$$\begin{cases} (z_{t,1})^r - U_{t,1}(z_{t,1}) = A_t(z_{t,1}) \\ z_{t,2} - U_{t,2}(z_{t,1}) \\ \vdots \\ z_{t,n} - U_{t,n}(z_{t,1}), \end{cases} \quad (26)$$

where $\deg U_{t,i} < r$ for each i . Now instead of evaluating the homotopy H at an ordinary point $(z, t) \in \Omega \times \mathbb{C}$, we may evaluate H at a point $(z, t) \in \mathbb{A}^n \times \mathbb{C}$, where \mathbb{A} is the quotient algebra $\mathbb{C}[u]/(u^r - U_{t,1}(u))$. When evaluating at the multivalued point \mathcal{Z}_t represented by Σ_t , we would take $z_{t,1} = u$, $z_{t,2} = U_{t,2}(u)$, ..., $z_{t,n} = U_{t,n}(u)$. This leads to a lift of H as a homotopy $H_{\mathbb{A}}: \Omega_{\mathbb{A}} \times \mathbb{C} \rightarrow \mathbb{A}^n$, for some open subset $\Omega_{\mathbb{A}}$ of \mathbb{A}^n .

In order to apply theorem 8, we need a homotopy over \mathbb{C} rather than \mathbb{A} . Therefore, let us show how to reformulate $H_{\mathbb{A}}$ as a homotopy $H^{[r]}: \Omega^{[r]} \times \mathbb{C} \rightarrow \mathbb{C}^{nr}$ for a suitable open subset $\Omega^{[r]}$ of \mathbb{C}^{nr} . The idea is to encode the system (26) by a vector

$$\text{Sys}(z_{t,1}^1, \dots, z_{t,1}^r) = ((U_{t,1})_0, \dots, (U_{t,1})_{r-1}, \dots, (U_{t,n})_0, \dots, (U_{t,n})_{r-1}) \in \mathbb{C}^{nr}.$$

More precisely, given a point

$$(\Sigma, t) = (\Sigma_{1,0}, \dots, \Sigma_{1,r-1}, \dots, \Sigma_{n,1}, \dots, \Sigma_{n,r-1}, t) \in \mathbb{C}^{nr} \times \mathbb{C},$$

we denote $\Sigma_i = \Sigma_{i,0} + \dots + \Sigma_{i,r-1} u^{r-1}$ for each i . Let $\mathbb{A} = \mathbb{C}[u]/(u^r - \Sigma_1(u))$ and consider the evaluation $y \in \mathbb{A}^n$ of H at $z_1 = u$, $z_2 = \Sigma_2(u)$, ..., $z_n = \Sigma_n(u)$ and t . This is possible if $z \in \Omega$ for any root z of the system $(z_1)^r - \Sigma_1(z_1) = 0$, $z_2 = \Sigma_2(z_1)$, ..., $z_n = \Sigma_n(z_1)$. There exists a unique point

$$Y = (Y_{1,0}, \dots, Y_{1,r-1}, \dots, Y_{n,1}, \dots, Y_{n,r-1}) \in \mathbb{C}^{nr},$$

such that $y_i = Y_{i,0} + \dots + Y_{i,r-1} u^{r-1}$ for all i . We take $H^{[r]}(\Sigma) = Y$. If H can be computed by a dag of size s_H then $H^{[r]}$ can be computed by a dag of size $s_{H^{[r]}} = \mathcal{O}(M(r) s_H)$, since a multiplication in \mathbb{A} can be done using a dag of size $\mathcal{O}(M(r))$.

THEOREM 10. *Let $(\Sigma, \mathbf{t}) \in \mathbb{C}^{nr} \times \mathbb{C}$ be such that $\Sigma \subseteq \Omega^{[r]}$ and $0 \in \mathbf{t}$. Assume that the system $H(z, t) = 0$ admits no multiple zeros for $t \in \mathbf{t} \cap \mathbb{R}^>$, and let $t_0 \in \mathbf{t} \cap \mathbb{R}^>$ and $z_*^1, \dots, z_*^r \in \mathbb{C}^n$ be such that $H(u_i, t_0) = 0$ for all i and*

$$\text{Sys}(z_*^1, \dots, z_*^r) \in \Sigma.$$

Let $J = (\partial H^{[r]}/\partial \Sigma)(\text{cen } \Sigma, \text{cen } \mathbf{t})$ and let $V \in \mathbb{C}^{nr \times nr}$ be an invertible matrix with $VJ \approx 1$. If

$$\Sigma - VH^{[r]}(\Sigma, \mathbf{t}) + (1 - V \frac{\partial H^{[r]}}{\partial \Sigma}(\Sigma, \mathbf{t})) \mathcal{B}(\text{rad } \Sigma) \subseteq \text{int}(\Sigma), \quad (27)$$

then there exist unique paths $z_t^1, \dots, z_t^r \in \Omega$ with $H(z_t^i, t) = 0$, $z_{t_0}^i = z_^i$ and*

$$\text{Sys}(z_t^1, \dots, z_t^r) \in \Sigma,$$

for all $i \in \{1, \dots, r\}$ and $t \in \mathbf{t} \cap \mathbb{R}^{\geq}$.

Proof. By theorem 8, there exists a unique solution $\Sigma_t \in \Sigma$ to the system $f^{[r]}(\Sigma_t, t) = 0$, for each $t \in \mathbf{t}$, whence a unique set $\{z_t^1, \dots, z_t^r\}$ with $\text{Sys}(z_t^1, \dots, z_t^r) = \Sigma_t$. The uniqueness implies that this set coincides with the set of analytic continuations of the solution paths of $f(z_t, t)$ from t_0 to t for each $t \in \mathbf{t} \cap \mathbb{R}^>$. After reordering, this shows that there exist unique paths $z_t^1, \dots, z_t^r \in \Omega$ with $H(z_t^i, t) = 0$, $z_{t_0}^i = z_*^i$ and $\text{Sys}(z_t^1, \dots, z_t^r) \in \Sigma$, for all $i \in \{1, \dots, r\}$ and $t \in \mathbf{t} \cap \mathbb{R}^>$. Now for $t \rightarrow 0$, solutions of monic equations of the form $z_{t,1}^r - \Sigma_1(z_{t,1}) = 0$ remain bounded. By continuity, the z_t^i therefore tend to limits in Ω , and $\text{Sys}(z_0^1, \dots, z_0^r) \in \Sigma$. \square

Using the univariate root certification methods from section 7.1, we may also compute ball enclosures for z_0^1, \dots, z_0^r . The theorem therefore provides a way to certify all solutions of a numeric homotopy associated to a polynomial system (11), even in the presence of multiple solutions.

Indeed, let $\{z_t^k: k \in K\}$ be the set of all solution paths. For some small $t_0 > 0$, we perform a certified homotopy continuation from $t = 1$ until $t = t_0$, using the techniques from section 6. This is possible since the $z_{t_0}^k$ are pairwise distinct, when assuming general position. We next partition $K = K^1 \amalg \dots \amalg K^\kappa$, such that $\{z_t^k: k \in K^i\}$ is either a singleton or a herd for each i . For each singleton, we try to apply theorem 8 for $t \ni 0$ and for each herd, we try to apply theorem 10. If this works, then we obtain the desired enclosures for the solutions of (11), counted with multiplicities. If not, then we choose a smaller t_0 and repeat the same procedure.

For the termination of this algorithm, it remains to be checked that theorem 10 indeed applies if t_0 is sufficiently small. In other words, setting $P^{[r]}(\Sigma) = f^{[r]}(\Sigma, 0)$, we have to show that $\partial P^{[r]}/\partial \Sigma$ is invertible. We will only give a rough justification, which we intend to work out in a forthcoming paper. Assuming the contrary and ‘‘general position’’, the perturbation $H^{[r]}$ of $P^{[r]}$ would exhibit a non trivial monodromy in t , and contradict our assumption that the set \mathcal{Z}_t is stable under monodromy. We finally notice that our algorithm also works in degenerate situations if we let z_t^1, \dots, z_t^r be a cluster of paths instead of a herd.

Remark 11. As we already noticed before, there is no purely numeric test for knowing whether a herd tends to an r -fold root α . Nevertheless, if we *assume* that this is indeed the case, then we notice that α can be approximated with a precision which is close to the current working precision. Indeed, if the herd is given by the system (26), then we may approximate α using $\tilde{\alpha}_1 := (U_{0,1})_{r-1}/r$, $\tilde{\alpha}_2 := U_{0,2}(\tilde{\alpha}_1)$, \dots , $\tilde{\alpha}_r := U_{0,r}(\tilde{\alpha}_1)$.

7.3. Algorithmic improvements

Although we have shown how to translate the homotopy $H_{\mathbb{A}}: \Omega_{\mathbb{A}} \times \mathbb{C} \rightarrow \mathbb{A}^n$ into a homotopy $H^{[r]}: \Omega^{[r]} \times \mathbb{C} \rightarrow \mathbb{C}^{nr}$, we do want to exploit the multiplication in \mathbb{A} for computational purposes. In particular, we want to exploit this structure for the computation of the Jacobian $J_{H^{[r]}}$. As in the case of usual Jacobians, we may compute $J_{H_{\mathbb{A}}}$ by evaluating H at $z_{t,1} = u$, $z_{t,2} = U_{t,2}(u) + \epsilon_2, \dots, z_{t,n} = U_{t,n}(u) + \epsilon_n$ and $t + \delta$ in the deformed algebra

$$\mathbb{D} = \mathbb{C}[u, \epsilon_1, \dots, \epsilon_n, \delta]/(u^r - U_{t,1}(u) - \epsilon_1, \epsilon_i \epsilon_j, \epsilon_i \delta, \delta^2).$$

Denoting the result of this evaluation by $y = (y_1, \dots, y_n)$, we may write $y_i = y_{i,\text{cst}} + y_{i,1} \epsilon_1 + \dots + y_{i,n} \epsilon_n + \dot{y}_i \delta$, where $y_{i,\text{cst}}$ and $y_{i,j}$ are polynomials of degrees $< r$ in u . Reinterpreting the $y_{i,j}$ as elements of \mathbb{A} (which is correct modulo an error in ϵ_1), we obtain

$$J_{H_{\mathbb{A}}} = \begin{pmatrix} y_{1,1} & \cdots & y_{1,n} & \dot{y}_1 \\ \vdots & & \vdots & \vdots \\ y_{n,1} & \cdots & y_{n,n} & \dot{y}_n \end{pmatrix} \in \mathbb{A}^{n \times (n+1)}.$$

Now for any $x \in \mathbb{A}$, multiplication by x in \mathbb{A} can be represented by a matrix $\text{Mat}(x) \in \mathbb{C}^{n \times n}$ in the monomial basis $1, u, \dots, u^{r-1}$ of \mathbb{A} . Similarly, any matrix $M \in \mathbb{A}^{m \times n}$ induces a $\mathbb{C}^{mr \times nr}$ block matrix

$$\text{Mat}(M) = \begin{pmatrix} \text{Mat}(M_{1,1}) & \cdots & \text{Mat}(M_{1,n}) \\ \vdots & & \vdots \\ \text{Mat}(M_{m,1}) & \cdots & \text{Mat}(M_{m,n}) \end{pmatrix}.$$

By construction, we now have

$$\begin{aligned} \frac{\partial H^{[r]}}{\partial \Sigma} &= \text{Mat}\left(\frac{\partial H_{\mathbb{A}}}{\partial z}\right) \\ \left(\frac{\partial H^{[r]}}{\partial \Sigma}\right)^{-1} &= \text{Mat}\left(\frac{\partial H_{\mathbb{A}}}{\partial z}\right)^{-1} \end{aligned}$$

Now the computation of $\partial H_{\mathbb{A}}/\partial z$ and its inverse can be done using dags of sizes $\mathcal{O}(n \mathbf{M}(r) s_H)$, whence multiplication of $\partial H^{[r]}/\partial \Sigma$ or its inverse with a vector in \mathbb{C}^{nr} can be done a dag of size $\mathcal{O}(n \mathbf{M}(r) s_H)$. In particular, the evaluation of the left hand side of (27) can be done using a dag of size $\mathcal{O}(n \mathbf{M}(r) s_H)$ over \mathbb{C} . This is better than a direct computation of $\partial H^{[r]}/\partial \Sigma$ which requires a dag of size $\mathcal{O}(n^2 \mathbf{M}(r) s_H)$.

A second issue which has been hidden by the current presentation concerns numeric stability. If the herd indeed tends to an r -fold root α when $t \rightarrow 0$, then $u^r - U_{t,1}(u)$ tends to $(u - \alpha_1)^r$. Now straightforward arithmetic in $\mathbb{C}[u]/(u - \alpha_1)^r$ tends to be quite unstable. For instance, the evaluation of a polynomial of degree d typically gives rise to a precision loss of $\mathcal{O}(d)$ digits. This can be avoided using a shift: instead of working in $\mathbb{A} = \mathbb{C}[u]/((u - \alpha_1)^r)$ and evaluating at $z_1 = u$, we rather work in $\mathbb{A}' = \mathbb{C}[u]/(u^r)$ and evaluate at $z_1 = u + \alpha$. More generally, if $\mathbb{A} = \mathbb{C}[u]/(u^r - U_{t,1}(u))$, then we take $\mathbb{A}' = \mathbb{C}[u]/((u - \sigma)^r - U_{t,1}(u - \sigma))$, where $\sigma = (U_{t,1})_{r-1}/r$, and evaluate at $z_1 = u + \sigma$.

Another question is whether we can avoid using the extra time parameter t for the final certification. Indeed, corollary 7 is sufficient for the certification of a single isolated root. More generally, let z_t^1, \dots, z_t^r be a cluster of solutions which tend to an r -fold root α . We may forget about the last equation P_n and, for some small $\delta \in \mathbb{C}$, compute all solutions to the system $P_1(z) = \dots = P_{n-1}(z) = z_n - \alpha_n - \delta = 0$ which are close to α (e.g. by homotopies starting at the $z_{i,t}$). The system $H' = (P_1, \dots, P_{n-1}): \mathbb{C}^n \rightarrow \mathbb{C}^{n-1}$ may then be regarded as a homotopy with respect to the time $z_n - \alpha_n$. Given a herd $z^1, \dots, z^{r'} \in \mathbb{C}^n$ of solution paths, we may then try to construct the system $(H')^{[r']}$ as usual and consider P_n as a polynomial equation on the 1-dimensional solution surface of this system. This more intrinsic technique is particularly effective if $r' = 1$, in which case we really have to compute the roots in a disk of a univariate analytic equation. For $r' > 1$, the homotopy H' does not need to be in general position, and we have not yet worked out the corresponding theory in detail.

7.4. Global certification

Even if the coefficients of the system (11) are all rational or algebraic, then the computed solutions are only numeric approximations. For some applications, it is useful to have exact representations of the solutions. This allows for instance to check whether a given other polynomial with rational coefficients vanishes on the solution set or on some points of the solutions set.

The Kronecker representation provides one useful exact representation for the set of solutions. Modulo a generic linear change of coordinates, we may assume without loss of generality that for any distinct solutions z, z' of (11), their first coordinates z_1 and z'_1 are also distinct. Let $z^1, \dots, z^k \in \mathbb{C}^n$ be the distinct solutions of (11). Then the Kronecker representation for $\mathcal{Z} = \{z^1, \dots, z^k\}$ is the unique n -tuple $(Q, V_2, \dots, V_n) = K^{\mathcal{Z}} = (Q^{\mathcal{Z}}, V_2^{\mathcal{Z}}, \dots, V_n^{\mathcal{Z}})$ of univariate polynomials with $\deg Q = k$, $Q_k = 1$, $\deg V_2 < k, \dots, \deg V_n < k$, such that \mathcal{Z} is annihilated by the system

$$\begin{aligned} Q(z_1) &= 0 \\ Q'(z_1) z_2 &= V_2(z_1) \\ &\vdots \\ Q'(z_1) z_n &= V_n(z_1). \end{aligned}$$

Assume now that $\mathcal{Z} = \mathcal{X} \amalg \mathcal{Y}$. Then we notice that $K^{\mathcal{Z}}$ can be computed in terms of $K^{\mathcal{X}}$ and $K^{\mathcal{Y}}$ using

$$\begin{aligned} Q^{\mathcal{Z}} &= Q^{\mathcal{X}} Q^{\mathcal{Y}} \\ V_i^{\mathcal{Z}} &= V_i^{\mathcal{X}} Q^{\mathcal{Y}} + Q^{\mathcal{X}} V_i^{\mathcal{Y}}, \end{aligned}$$

for all i . This yields an efficient dichotomic algorithm for the numeric computation of $K^{\mathcal{Z}}$.

Assume now that (11) has rational coefficients and that we have computed numeric approximations $\tilde{z}^1, \dots, \tilde{z}^k$ of z^1, \dots, z^k with bit precision p . By remark 11, even if \tilde{z}^i approximates a multiple root, then \tilde{z}^i is still known with a precision close to p . Using the above method, we may thus compute a numeric approximation \tilde{K}^Z of K^Z with an accuracy of approximately p bits. We apply rational number reconstruction [GG02, Chapter 5] in order to provide a guess for K^Z with rational coefficients. We may check whether this guess is correct by evaluating P at $z_1 = u, z_2 = V_2(u)/Q'(u), \dots, z_n = V_n(u)/Q'(u)$ over $\mathbb{A} = \mathbb{Q}[u]/(Q(u))$. By evaluating over suitable algebras with nilpotent elements, we may check in a similar way whether the multiplicity of each root matches with the numeric multiplicity. If one of these checks fails, then we double the bit precision, use Newton's method to improve the approximations $\tilde{z}^1, \dots, \tilde{z}^k$, and keep iterating.

7.5. Local algebras

Consider a cluster $(z_t^k)_{k \in C}$ of paths which tend to a common root α and decompose $C = H^1 \amalg \dots \amalg H^\eta$ such that $(z_t^i)_{i \in H^j}$ is a herd in the cluster for each j . Each herd $(z_t^i)_{i \in H^j}$ gives rise to an ideal \mathfrak{J}_t^j which is represented by a system of the form (26). The intersection

$$\mathfrak{J}_t = \mathfrak{J}_t^1 \amalg \dots \amalg \mathfrak{J}_t^\eta$$

can be computed by Gröbner basis techniques and the limit \mathfrak{J}_0 at $t = 0$ yields the local ideal of the system (11) at the multiple root.

Example 12. Let us consider the very simple example

$$\begin{aligned} P_1 &= z_1^2 \\ P_2 &= z_2^2 \end{aligned}$$

with the homotopy

$$\begin{aligned} H_1 &= (1-t)z_1^2 + t(z_1^2 - 1) = z_1^2 - t \\ H_2 &= (1-t)z_2^2 + t(z_2^2 - 1) = z_2^2 - t \end{aligned}$$

For small $t > 0$, we have the solution paths

$$\begin{aligned} z_t^1 &= (\sqrt{t}, \sqrt{t}) \\ z_t^2 &= (-\sqrt{t}, -\sqrt{t}) \\ z_t^3 &= (\sqrt{t}, -\sqrt{t}) \\ z_t^4 &= (-\sqrt{t}, \sqrt{t}). \end{aligned}$$

Both (z_t^1, z_t^2) and (z_t^3, z_t^4) form a herd, with corresponding ideals

$$\begin{aligned} \mathfrak{J}_t^1 &= (z_1^2 - t, z_2 - z_1) \\ \mathfrak{J}_t^2 &= (z_1^2 - t, z_2 + z_1). \end{aligned}$$

We have

$$\mathfrak{J}_t = (z_1^2 - t, z_2^2 - z_1^2)$$

and $\mathfrak{J}_0 = (z_1^2, z_2^2)$.

BIBLIOGRAPHY

- [AH83] G. Alefeld and J. Herzberger. *Introduction to interval analysis*. Academic Press, New York, 1983.

- [ANS08] ANSI/IEEE. IEEE standard for binary floating-point arithmetic. Technical Report, ANSI/IEEE, New York, 2008. ANSI-IEEE Standard 754-2008. Revision of IEEE 754-1985, approved on June 12, 2008 by IEEE Standards Board.
- [BHSW06] D. Bates, J. Hauenstein, A. Sommese and C. Wampler. Bertini: software for numerical algebraic geometry. <http://www.nd.edu/~sommese/bertini/>, 2006.
- [BSHW08] D.J. Bates, A.J. Sommese, J.D. Hauenstein and C.W. Wampler. Adaptive multiprecision path tracking. *SIAM Journal on Numerical Mathematics*, 46(2):722–746, 2008.
- [Dur08] C. Durvy. *Algorithmes pour la décomposition primaire des idéaux polynomiaux de dimension nulle donnés en évaluation*. PhD thesis, Univ. de Versailles (France), 2008.
- [GG02] J. von zur Gathen and J. Gerhard. *Modern Computer Algebra*. Cambridge University Press, 2-nd edition, 2002.
- [GHHM+97] M. Giusti, K. Hägele, J. Heintz, J.E. Morais, J.L. Montaña and L.M. Pardo. Lower bounds for diophantine approximation. *Journal of Pure and Applied Algebra*, 117–118:277–317, 1997.
- [GHMP95] M. Giusti, J. Heintz, J.E. Morais and L.M. Pardo. When polynomial equation systems can be solved fast? In G. Cohen, M. Giusti and T. Mora, editors, *Proc. AAECC'11*, volume 948 of *Lecture Notes in Computer Science*. Springer Verlag, 1995.
- [HLRZ00] G. Hanrot, V. Lefèvre, K. Ryde and P. Zimmermann. MPFR, a C library for multiple-precision floating-point computations with exact rounding. <http://www.mpfr.org>, 2000.
- [JKDW01] L. Jaulin, M. Kieffer, O. Didrit and E. Walter. *Applied interval analysis*. Springer, London, 2001.
- [Kea94] R.B. Kearfott. An interval step control for continuation methods. *SIAM J. Numer. Anal.*, 31(3):892–914, 1994.
- [Kra69] R. Krawczyk. Newton-algorithmen zur bestimmung von nullstellen mit fehler-schranken. *Computing*, 4:187–201, 1969.
- [Kul08] U.W. Kulisch. *Computer Arithmetic and Validity. Theory, Implementation, and Applications*. Number 33 in Studies in Mathematics. De Gruyter, 2008.
- [Lec01] G. Lecerf. *Une alternative aux méthodes de réécriture pour la résolution des systèmes algébriques*. PhD thesis, École polytechnique, 2001.
- [Ley09] A. Leykin. NAG. <http://www.math.uic.edu/~leykin/NAG4M2>, 2009. Macaulay 2 package for numerical algebraic geometry.
- [MB04] K. Makino and M. Berz. Suppression of the wrapping effect by Taylor model-based validated integrators. Technical Report MSU Report MSUHEP 40910, Michigan State University, 2004.
- [MB96] K. Makino and M. Berz. Remainder differential algebras and their applications. In M. Berz, C. Bischof, G. Corliss and A. Griewank, editors, *Computational differentiation: techniques, applications and tools*, pages 63–74. SIAM, Philadelphia, 1996.
- [MKC09] R.E. Moore, R.B. Kearfott and M.J. Cloud. *Introduction to Interval Analysis*. SIAM Press, 2009.
- [Moo66] R.E. Moore. *Interval Analysis*. Prentice Hall, Englewood Cliffs, N.J., 1966.
- [Mor87] A.P. Morgan. *Solving polynomial systems using continuation for engineering and scientific problems*. Prentice-Hall, Englewood Cliffs, N.J., 1987.
- [Neu90] A. Neumaier. *Interval methods for systems of equations*. Cambridge university press, Cambridge, 1990.
- [Rum10] S.M. Rump. Verification methods: rigorous results using floating-point arithmetic. *Acta Numerica*, 19:287–449, 2010.
- [Rum80] S.M. Rump. *Kleine Fehlerschranken bei Matrixproblemen*. PhD thesis, Universität Karlsruhe, 1980.
- [Sch82] A. Schönhage. The fundamental theorem of algebra in terms of computational complexity. Technical Report, Math. Inst. Univ. of Tübingen, 1982.
- [SW05] A.J. Sommese and C.W. Wampler. *The Numerical Solution of Systems of Polynomials Arising in Engineering and Science*. World Scientific, 2005.

-
- [vdH09] J. van der Hoeven. Ball arithmetic. Technical Report, HAL, 2009. <http://hal.archives-ouvertes.fr/hal-00432152/fr/>.
- [vdH11] J. van der Hoeven. Efficient root counting for analytic functions on a disk. Technical Report, HAL, 2011. <http://hal.archives-ouvertes.fr/hal-00583139/fr/>.
- [Ver96] J. Verschelde. *Homotopy continuation methods for solving polynomial systems*. PhD thesis, Katholieke Universiteit Leuven, 1996.
- [Ver99] J. Verschelde. PHCpack: a general-purpose solver for polynomial systems by homotopy continuation. *ACM Transactions on Mathematical Software*, 25(2):251–276, 1999. Algorithm 795.