



HAL
open science

The Ginzburg-Landau functional with a discontinuous and rapidly oscillating pinning term. Part II: the non-zero degree case

Mickaël dos Santos

► **To cite this version:**

Mickaël dos Santos. The Ginzburg-Landau functional with a discontinuous and rapidly oscillating pinning term. Part II: the non-zero degree case. 2011. hal-00587804v2

HAL Id: hal-00587804

<https://hal.science/hal-00587804v2>

Preprint submitted on 22 Apr 2011 (v2), last revised 6 Nov 2011 (v4)

HAL is a multi-disciplinary open access archive for the deposit and dissemination of scientific research documents, whether they are published or not. The documents may come from teaching and research institutions in France or abroad, or from public or private research centers.

L'archive ouverte pluridisciplinaire **HAL**, est destinée au dépôt et à la diffusion de documents scientifiques de niveau recherche, publiés ou non, émanant des établissements d'enseignement et de recherche français ou étrangers, des laboratoires publics ou privés.

The Ginzburg-Landau functional with a discontinuous and rapidly oscillating pinning term. Part II: the non-zero degree case

Mickaël DOS SANTOS*

April 22, 2011

Abstract

We consider minimizers of a Ginzburg-Landau energy with a discontinuous and rapidly oscillating pinning term, subject to a Dirichlet boundary condition of degree $d > 0$. We prove that minimizers have exactly d isolated zeros (vortices). These vortices are of degree 1 and pinned by the impurities. As in the standard case studied by Bethuel, Brezis and Hélein, the macroscopic location of vortices is governed by vortex/vortex and vortex/ boundary repelling effects. In some special cases we prove that their macroscopic location tends to minimize the renormalized energy of Bethuel-Brezis-Hélein. In addition, impurities affect the microscopic location of vortices.

Contents

1	Introduction	2
2	Main results	7
3	Shrinking holes for weighted Dirichlet functionals	9
3.1	Existence results	10
3.1.1	Existence of minimizing maps defined in a perforated domain	10
3.1.2	Existence of an optimal perforated domain	11
3.2	Dirichlet Vs Degree Conditions in a fixed perforated domain	11
3.3	Optimal perforated domains for the degree conditions	12
3.3.1	The case of the periodic pinning term	13
3.3.2	Sharper result in the periodic case with dilution	15
3.3.3	The case of a general pinning with variable sizes of inclusions	15
4	The pinned Ginzburg-Landau functional	15
4.1	Sharp Upper Bound, η -ellipticity and Uniform Convergence	16
4.1.1	Sharp Upper Bound and an η -ellipticity result	16
4.1.2	Uniform convergence to 1 of $ \hat{v}_\varepsilon $ in $\mathbb{R}^2 \setminus K$, K closed set, $\bar{\omega} \in K$	17
4.2	Bad discs	19
4.2.1	Construction and first properties of bad discs	19
4.2.2	Location and degree of bad discs	22

*Université de Lyon, CNRS UMR 5208, INSA de Lyon, Institut Camille Jordan, 20, avenue Albert Einstein, 69621 Villeurbanne Cedex, France

4.3	H_{loc}^1 -weak convergence	22
4.4	The small bad discs	25
4.4.1	Definition	25
4.4.2	Separation of small bad discs	26
4.4.3	There are exactly d small bad discs	26
4.5	Asymptotic expansion of $F_\varepsilon(v_\varepsilon)$	29
4.5.1	Statement of the main result and corollaries	29
4.5.2	Proof of Theorem 5	30
4.5.3	Proof of Proposition 25	30
4.6	Proof of Theorems 2 and 3	33
A Proof of Proposition 2		33
B Proof of Proposition 3		34
C Proof of Proposition 4		36
C.1	The separation process	36
C.2	The separation process gives a natural partition of Ω	38
C.3	Proof of Proposition 4	43
D Proof of Proposition 5		43
D.1	Description of the special solution U_ε	43
D.2	Behavior of almost minimizers of $I_{\rho,\varepsilon}$	45
D.2.1	Useful results for the periodic situation	45
D.2.2	Lower bound on circles	47
D.3	Proof of the first part of Proposition 5	47
D.4	Proof of the second part of Proposition 5	49
D.5	Proof of the third part of Proposition 5	50
E Proof of Propositions 8 and 9		53
E.1	An important effect of the dilution of inclusions	53
E.2	Proof of Proposition 8	54
E.3	Proof of Proposition 9	58
F Proof of Proposition 20		61

1 Introduction

In this article we let $\Omega \subset \mathbb{R}^2$ be a simply connected domain and let $a_\varepsilon : \Omega \rightarrow \{b, 1\}$, $b \in (0, 1)$ be a measurable function. We associate to a_ε the pinned Ginzburg-Landau energy

$$E_\varepsilon(u) = \frac{1}{2} \int_{\Omega} \left\{ |\nabla u(x)|^2 + \frac{1}{2\varepsilon^2} (a_\varepsilon(x)^2 - |u(x)|^2)^2 \right\} dx. \quad (1.1)$$

Here, $u \in H^1(\Omega, \mathbb{C})$ and $\varepsilon > 0$ is the inverse of the Ginzburg-Landau parameter.

Our goal is to consider a discontinuous and rapidly oscillating pinning term (the pinning term is $a_\varepsilon : \Omega \rightarrow \{b, 1\}$). Our pinning term is periodic with respect to a $\delta \times \delta$ -grid with $\delta = \delta(\varepsilon) \rightarrow 0$ as $\varepsilon \rightarrow 0$. We are interested in the minimization of (1.1) in $H^1(\Omega, \mathbb{C})$ subject

to a Dirichlet boundary condition: we fix $g \in C^\infty(\partial\Omega, \mathbb{S}^1)$ and thus the set of the test functions is

$$H_g^1 = \{u \in H^1(\Omega, \mathbb{C}) \mid \text{tr}_{\partial\Omega} u = g\}.$$

The situation where $d = \text{deg}_{\partial\Omega}(g) = 0$ was studied in detail in [11]. The non zero degree case ($d = \text{deg}_{\partial\Omega}(g) > 0$) is the purpose of the present article. Recall that the degree (winding number) of g is defined as

$$\text{deg}_{\partial\Omega}(g) := \frac{1}{2\pi} \int_{\partial\Omega} g \times \partial_\tau g \, d\tau.$$

Here " \times " stands for the vectorial product in \mathbb{C} , *i.e.* $z_1 \times z_2 = \text{Im}(\overline{z_1} z_2)$, $z_1, z_2 \in \mathbb{C}$, and ∂_τ is the tangential derivative.

This energy is a simplification of the full Ginzburg-Landau energy (see Eq. (1.2)) whose minimizers model the state of a Type II superconductor (the parameter ε corresponds to a material parameter, this parameter is small for Type II superconductor) [22], [19]. The pinning term models a heterogenous superconductor [14].

Physical informations which can be obtained with the simplification of the full Ginzburg-Landau energy are quantization and location of zeros of minimizers. Their zeros represent the centers of small areas where the superconductivity is destroyed. These areas are called vorticity defects. Here the superconductor is a cylinder whose cross section is Ω and the vorticity defects (under some special conditions) takes the form of small wires parallel to the superconductor [22], [19].

Before going further, let us summarize two previous works in related directions [16], [1]. In these works, the role of the pinning term is identified: its points of *minimum* attract the vorticity defaults.

In [16], Lassoued and Mironescu considered the case where $a_\varepsilon \equiv a$. Here, the pinning term $a = \begin{cases} b & \text{in } \omega \\ 1 & \text{in } \Omega \setminus \omega \end{cases}$, $0 < b < 1$, and ω is a smooth inner domain of Ω . These authors proved that the vorticity defaults are localized in ω and that their position is governed by a renormalized energy (in the spirit of the [4]).

In [1], Aftalion, Sandier and Serfaty considered a smooth and ε -dependent pinning term a_ε . Their study allows to consider the case where the pinning term has fast oscillations: it is a perturbation of a fixed smooth function $\tilde{b} : \Omega \rightarrow [b, 1]$ s.t. $\tilde{b} \leq a_\varepsilon$.

They considered the following hypotheses on a_ε, \tilde{b} :

- $|\nabla a_\varepsilon| \leq C |\ln \varepsilon|$
- there is $\sigma_\varepsilon \in \mathbb{R}$ s.t. $\sigma_\varepsilon = o_\varepsilon((\ln |\ln \varepsilon|)^{-1/2})$ and for all $x \in \Omega$, we have

$$\min_{B(x, \sigma_\varepsilon)} \{a_\varepsilon - \tilde{b}\} = 0.$$

These authors study a full Ginzburg-Landau energy GL_ε with a pinning term:

$$GL_\varepsilon(u, A) = \frac{1}{2} \int_{\Omega} \left\{ |\text{curl} A - h_{\text{ex}}|^2 + |(\nabla - iA)u|^2 + \frac{1}{2\varepsilon^2} (a_\varepsilon^2 - |u|^2)^2 \right\}. \quad (1.2)$$

We denoted by A the electromagnetic vector potential of the induced field and by h_{ex} the intensity of the applied magnetic field (see [19] for more details).

In the study of the full Ginzburg-Landau functional without pinning term GL_ε^0 (GL_ε^0 is obtained from (1.2) by taking $a_\varepsilon \equiv 1$), the vorticity defaults appear for large apply

magnetic field. They are characterized by two facts: the presence of isolated zeros x_i of a map u with a non zero degree around small circles centered in x_i and the existence of a magnetic field inside the domain. The nature of the superconductivity makes that both facts appear together. Assuming that the intensity of the applied field h_{ex} depends on $0 < \varepsilon < 1$ and that $h_{\text{ex}}/|\ln \varepsilon| \rightarrow \Lambda \in \mathbb{R}_+^*$, for the classical full Ginzburg-Landau energy, it is well known (see *e.g.* [19]) that there is an inner domain ω_Λ (non decreasing with Λ) s.t., when $\varepsilon \rightarrow 0$, the vorticity defaults are "uniformly located" by ω_Λ .

In [1], the authors proved the existence of ω_Λ , an inner set of Ω , where the penetration of the magnetic field is located. In contrast with the situation without pinning term, the presence of a_ε makes that, in general, the vortices are not uniformly located in ω_Λ . Although in the proofs of the main results of [1], the minimal points of \tilde{b} seem play the role of a pinning site, this fact is not proved. They expect that the most favorable pinning sites should be close to the *minima* of $\tilde{b} : \omega_\Lambda$ should be located close to the points of *minimum* of \tilde{b} .

One of our goals is to prove that the minimum points of a rapidly oscillating and discontinuous pinning term attract the vorticity defaults.

Before going further, we construct our pinning term a_ε .

Consider $\delta = \delta(\varepsilon) \in (0, 1)$, $\lambda = \lambda(\varepsilon) \in (0, 1]$ and let $\omega \subset Y = (-1/2, 1/2)^2$ be a smooth bounded and simply connected open set s.t. $(0, 0) \in \omega$ and $\bar{\omega} \subset Y$. For $k, l \in \mathbb{Z}$ we denote

$$Y_{k,l}^\delta := \delta \cdot Y + (\delta k, \delta l), \quad \Omega_\delta^{\text{incl}} = \bigcup_{Y_{k,l}^\delta \subset \Omega} \overline{Y_{k,l}^\delta}, \quad \omega^\lambda = \lambda \cdot \omega$$

$$\omega_{\text{per}}^\lambda = \bigcup_{(k,l) \in \mathbb{Z}^2} \left\{ \omega^\lambda + (k, l) \right\} \quad \text{and} \quad \omega_\varepsilon = \bigcup_{\substack{(k,l) \in \mathbb{Z}^2 \text{ s.t.} \\ Y_{k,l}^\delta \subset \Omega}} \left\{ \delta \cdot \omega^\lambda + (\delta k, \delta l) \right\}.$$

For $b \in (0, 1)$, we define

$$a^\lambda : \mathbb{R}^2 \rightarrow \begin{cases} \{b, 1\} \\ b \text{ if } x \in \omega_{\text{per}}^\lambda \\ 1 \text{ otherwise} \end{cases} \quad \text{and} \quad a_\delta : \mathbb{R}^2 \rightarrow \begin{cases} \{b, 1\} \\ b \text{ if } x \in \omega_\varepsilon \\ 1 \text{ otherwise} \end{cases}.$$

The connected components of $\{a_\varepsilon = b\} = \omega_\varepsilon$ are called inclusions or impurities.

In the rest of this article $\lambda = \lambda(\varepsilon)$ and $\delta = \delta(\varepsilon)$ are functions of ε . We assume that $\delta \rightarrow 0$ as $\varepsilon \rightarrow 0$. In addition, we assume that either $\lambda \equiv 1$, or $\lambda \rightarrow 0$ as $\varepsilon \rightarrow 0$. The case $\lambda \rightarrow 0$ is the *dilute case*.

We make the assumption

$$\lim_{\varepsilon} \frac{|\ln(\lambda\delta)|^3}{|\ln \varepsilon|} = 0. \quad (1.3)$$

Remark 1. • This is slightly more restrictive than asking that $\lambda\delta \gg \varepsilon^\alpha$ for some $\alpha \in (0, 1)$.

- In [1] and in the situation where we have a bounded number of zeros, the smooth pinning term $a_\varepsilon^{\text{smooth}}$ satisfies the condition $|\nabla a_\varepsilon^{\text{smooth}}| \leq C|\ln \varepsilon|$. In order to compare this assumption with (1.3), we may consider a regularization of our pinning term by a mollifier $\rho_t(x) = \rho(x/t)$. A suitable scale t to have a complete view of the variations of a_ε is $t = \lambda\delta$. Thus, $|\nabla(\rho_{\lambda\delta} * a_\varepsilon)|$ is of order $\frac{1}{\lambda\delta}$. Consequently, the condition (1.3) allows to consider a more rapidly oscillating than the condition in [1]. Indeed, we have $\ln |\nabla a_\varepsilon^{\text{smooth}}| \leq \ln |\ln \varepsilon| + C$ and on the other hand (1.3) is equivalent to $\ln |\nabla(\rho_{\lambda\delta} * a_\varepsilon)| \sim |\ln(\lambda\delta)| = o(|\ln \varepsilon|^{1/3})$.

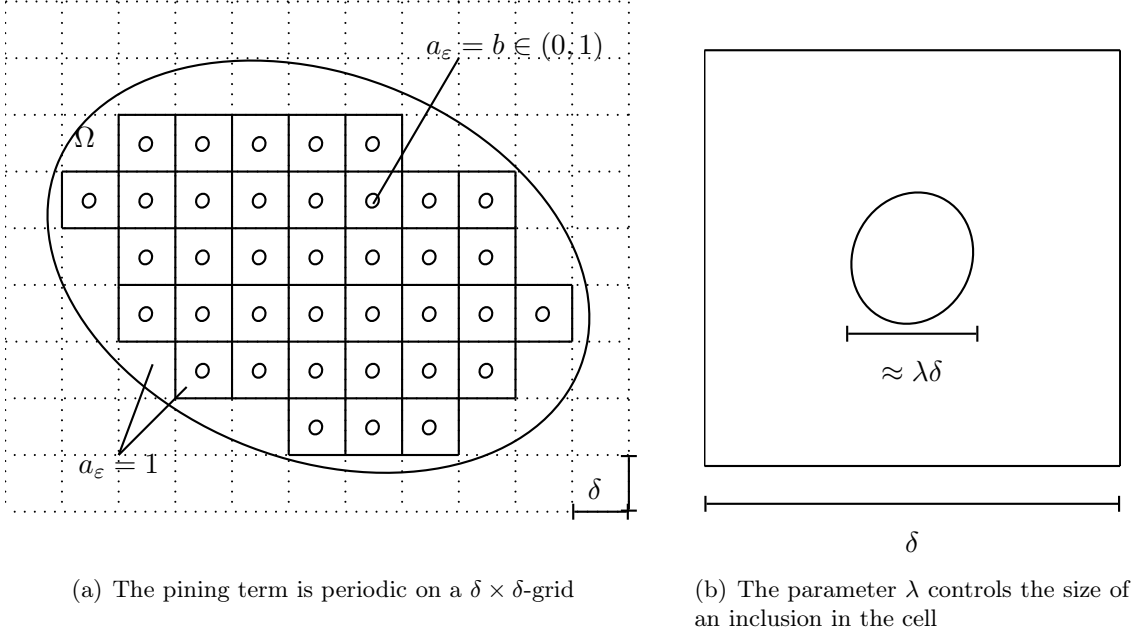

Figure 1: The periodic pinning term

We denote by U_ε **the** unique global minimizer of E_ε in H_1^1 (see [16]). Clearly, U_ε satisfies

$$\begin{cases} -\Delta U_\varepsilon = \frac{1}{\varepsilon^2} U_\varepsilon (a_\varepsilon^2 - U_\varepsilon^2) & \text{in } \Omega \\ U_\varepsilon = 1 & \text{on } \partial\Omega \end{cases}. \quad (1.4)$$

This special solution may be seen as a regularization of a_ε . For example, one may easily prove that U_ε is exponentially close to a_ε far away from $\partial\omega_\varepsilon$. Namely, we have

Proposition 1. *There are $C, \alpha > 0$ independent of ε, R s.t.*

$$|a_\varepsilon - U_\varepsilon| \leq C e^{-\frac{\alpha R}{\varepsilon}} \text{ in } V_R := \{x \in \Omega \mid \text{dist}(x, \partial\omega_\varepsilon) \geq R\}, \quad (1.5)$$

$$|\nabla U_\varepsilon| \leq \frac{C e^{-\frac{\alpha R}{\varepsilon}}}{\varepsilon} \text{ in } W_R := \{x \in \Omega \mid \text{dist}(x, \partial\omega_\varepsilon), \text{dist}(x, \partial\Omega) \geq R\}. \quad (1.6)$$

A similar result was proved in [12] (Proposition 2). The above proposition is proved using exactly the same arguments.

As in [16], we define

$$F_\varepsilon(v) = \frac{1}{2} \int_\Omega \left\{ U_\varepsilon^2 |\nabla v|^2 + \frac{1}{2\varepsilon^2} U_\varepsilon^4 (1 - |v|^2)^2 \right\}.$$

Then we have for all $v \in H_g^1$, (see [16])

$$E_\varepsilon(U_\varepsilon v) = E_\varepsilon(U_\varepsilon) + F_\varepsilon(v).$$

Therefore, u_ε is a minimizer of E_ε if and only if $u_\varepsilon = U_\varepsilon v_\varepsilon$ where v_ε is a minimizer of F_ε in H_g^1 . Consequently, the study of a minimizer $u_\varepsilon = U_\varepsilon v_\varepsilon$ of E_ε in H_g^1 (location of zeros and asymptotics) can be performed by combining the asymptotic of U_ε with one of v_ε .

Our main result is the following

Theorem 1. Assume that λ, δ satisfy (1.3) and that $\lambda \rightarrow 0$.

Quantization. There are $\varepsilon_0 > 0$, $c > 0$ and $\eta_0 > 0$ s.t. for $0 < \varepsilon < \varepsilon_0$:

1. v_ε has exactly d zeros $x_1^\varepsilon, \dots, x_d^\varepsilon$,
2. $B(x_i^\varepsilon, c\lambda\delta) \subset \omega_\varepsilon$ and
3. for $\rho = \rho(\varepsilon) \downarrow 0$ s.t. $|\ln \rho|/|\ln \varepsilon| \rightarrow 0$, there is $C > 0$ independent of ε satisfying

$$|v_\varepsilon| \geq 1 - C \sqrt{\frac{|\ln \rho|}{|\ln \varepsilon|}} \text{ in } \Omega \setminus \cup B(x_i^\varepsilon, \rho).$$

4. for $\varepsilon < \varepsilon_0$, $\deg_{\partial B(x_i^\varepsilon, \varepsilon)}(v_\varepsilon) = 1$.

Location.

- The macroscopic position of the zeros tends to minimize the renormalized energy of Bethuel-Brezis-Hélein W_g (defined in [4], Chapter I Eq. (47)):

$$\limsup W_g(x_1^\varepsilon, \dots, x_d^\varepsilon) = \min_{\substack{a_1, \dots, a_d \in \Omega \\ a_i \neq a_j}} W_g(a_1, \dots, a_d)$$

Here the renormalized energy W_g is considered with all the degrees equal to 1, thus we do not specify the degrees in its notation.

- The microscopic position of the zeros inside ω_ε tends to be dependent **only** on ω and b : letting

$$\hat{x}_i^\varepsilon := \frac{x_i^\varepsilon - \delta \cdot \left\lfloor \frac{x_i^\varepsilon}{\delta} \right\rfloor}{\lambda} \in \omega,$$

then, for $\varepsilon_n \downarrow 0$ s.t. $\hat{x}_i^{\varepsilon_n} \rightarrow \hat{a}_i$, we have $\hat{a}_i \in \omega$ which minimizes a renormalized energy \tilde{W}_1 which depends only on ω and $b \in (0, 1)$.

Remark 2. 1. The renormalized energy defined in [4]

$$W_g : \{\{a_1, \dots, a_d\} \subset \Omega \mid a_i \neq a_j \text{ for } i \neq j\} \rightarrow \mathbb{R}$$

governs the location of the zeros in the situation where $a_\varepsilon \equiv 1$ (homogenous case): the zeros tend to minimize W_g . In this article we will consider only the renormalized energy with the degree equal 1. Therefore, from smoothness of W_g (see [4] and [10]), up to pass to a subsequence, the zeros converge to a minimizer of W_g .

This location is strongly correlated with the Dirichlet boundary condition $g \in C^\infty(\partial\Omega, \mathbb{S}^1)$. Moreover, minimizers of W_g are subject of two repulsive effects: there is $\eta_0 > 0$ (depending only on Ω and g) s.t. if $\{a_1, \dots, a_d\}$ minimizes W_g , then $|a_i - a_j| \geq \eta_0$ and $\text{dist}(a_i, \partial\Omega) \geq \eta_0$, $i, j \in \{1, \dots, d\}, i \neq j$.

2. The result about the macroscopic position of the periodic and diluted pinning term may be sum up as: *the macroscopic position of the zeros tend to be the same than in the homogenous case* ($a_\varepsilon \equiv 1$).
3. The microscopic location of the zeros (position inside an inclusion) is independent of the boundary condition. For example, in the situation $\omega = B(0, r_0)$, i.e., the inclusions are discs, this position should be the center of the inclusion. This fact is not proved yet.

2 Main results

We present in this section several extensions of the above result dropping either the dilution of the inclusion ($\lambda \equiv 1$ instead of $\lambda \rightarrow 0$) or the periodic structure. The main results of this section are obtained under the condition: $\lambda\delta$ satisfies (1.3).

Our sharper results are shared into four theorems:

- The first theorem (Theorem 2) gives informations on the zeros of minimizers $u_\varepsilon, v_\varepsilon$ (quantification and location).
- The second (Theorem 3) theorem establishes the asymptotics of v_ε .
- The third theorem (Theorem 4) establishes, under the additional hypothesis $\lambda \rightarrow 0$, that the microscopic position of the zeros is independent of the boundary condition g .
- The last theorem (Theorem 5) gives an expansion of $F_\varepsilon(v_\varepsilon)$.

The technics developed in this paper allows to consider either the case $\lambda \rightarrow 0$ or $\lambda \equiv 1$. The results in the dilute case are more precise. One may drop the periodic structure for the pinning term and consider impurities (the connected components of $\omega_\varepsilon = \{a_\varepsilon = b\}$) with different sizes.

More precisely we may consider the pinning term defined as follow:

- Fix $P \in \mathbb{N}^*$, $j \in \{1, \dots, P\}$ and $1 > \varepsilon > 0$. We consider $M_j^\varepsilon \in \mathbb{N}$ and

$$\mathcal{M}_j^\varepsilon = \begin{cases} \emptyset & \text{if } M_j^\varepsilon = 0 \\ \{1, \dots, M_j^\varepsilon\} & \text{if } M_j^\varepsilon \in \mathbb{N}^* \end{cases}.$$

- The sets $\mathcal{M}_j^\varepsilon$'s are s.t. (for sufficiently small ε) one may fix $y_{i,j}^\varepsilon \in \Omega$ s.t. for $(i, j) \neq (i', j')$, $i \in \mathcal{M}_j^\varepsilon$, $i' \in \mathcal{M}_{j'}^\varepsilon$, we have

$$|y_{i,j}^\varepsilon - y_{i',j'}^\varepsilon| \geq \delta^j + \delta^{j'} \text{ and } \text{dist}(y_{i,j}^\varepsilon, \partial\Omega) \geq \delta^j. \quad (2.1)$$

For sake of simplicity, we assume that there are $\eta > 0$ s.t. for small ε , we have $M_1^\varepsilon \geq d = \text{deg}_{\partial\Omega}(g)$ and

$$\min \left\{ \min_{i=1, \dots, d} \text{dist}(y_{i,1}^\varepsilon, \partial\Omega), \min_{\substack{i, i'=1, \dots, d \\ i \neq i'}} |y_{i,1}^\varepsilon - y_{i',1}^\varepsilon| \right\} \geq \eta. \quad (2.2)$$

- We now define the domain which models the impurities:

$$\omega_\varepsilon = \bigcup_{j=1}^P \bigcup_{i \in \mathcal{M}_j^\varepsilon} \{y_{i,j}^\varepsilon + \delta^j \cdot \omega^\lambda\}, \quad \omega^\lambda = \lambda \cdot \omega.$$

The pinning term is

$$a_\varepsilon : \mathbb{R}^2 \rightarrow \begin{cases} \{b, 1\} \\ 1 & \text{if } x \notin \omega_\varepsilon \\ b & \text{if } x \in \omega_\varepsilon \end{cases}$$

The values of the pinning term are represented Figure 2.

Our main results take the form of four theorems:

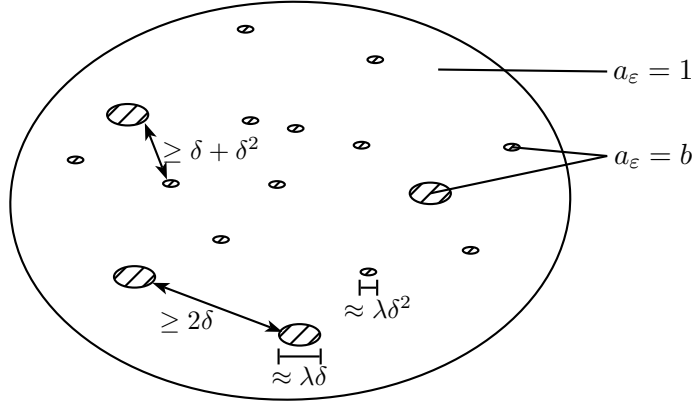

Figure 2: Representation of the pinning term with $P = 2$

Theorem 2. Assume that λ, δ satisfy (1.3) and if the pinning term is not periodic (represented Figure 2) then we assume that $\lambda |\ln \delta| \rightarrow 0$.

There is $\varepsilon_0 > 0$ s.t.:

1. for $0 < \varepsilon < \varepsilon_0$, v_ε has exactly d zeros $x_1^\varepsilon, \dots, x_d^\varepsilon$,
2. there are $c > 0$ and $\eta_0 > 0$ s.t. for $\varepsilon < \varepsilon_0$, $B(x_i^\varepsilon, c\lambda\delta) \subset \omega_\varepsilon$ and

$$\min_i \left\{ \min_{j \neq i} |x_i^\varepsilon - x_j^\varepsilon|, \text{dist}(x_i^\varepsilon, \partial\Omega) \right\} \geq \eta_0.$$

In particular, if the pinning term is not periodic, then the zeros are trapped by the largest inclusions (those of size $\lambda\delta$).

3. for $\rho = \rho(\varepsilon) \downarrow 0$ s.t. $|\ln \rho|/|\ln \varepsilon| \rightarrow 0$, we have for $\varepsilon < \varepsilon_0$,

$$|v_\varepsilon| \geq 1 - C \sqrt{\frac{|\ln \rho|}{|\ln \varepsilon|}} \text{ in } \Omega \setminus \cup B(x_i^\varepsilon, \rho).$$

Here C is independent of ε .

4. for $\varepsilon < \varepsilon_0$, $\text{deg}_{\partial B(x_i^\varepsilon, \varepsilon)}(v_\varepsilon) = 1$.

Theorem 3. Assume that λ, δ satisfy (1.3) and if the pinning term is not periodic (represented Figure 2) then we assume that $\lambda |\ln \delta| \rightarrow 0$.

Let $\varepsilon_n \downarrow 0$, up to subsequence, we have the existence of $a_1, \dots, a_d \in \Omega$, d distinct points s.t. $x_i^{\varepsilon_n} \rightarrow a_i$ and

$$|v_{\varepsilon_n}| \rightarrow 1 \text{ and } v_{\varepsilon_n} \rightharpoonup v_* \text{ in } H_{\text{loc}}^1(\overline{\Omega} \setminus \{a_1, \dots, a_d\}, \mathbb{S}^1)$$

where v_* solves

$$\begin{cases} -\text{div}(\mathcal{A}\nabla v_*) = (\mathcal{A}\nabla v_* \cdot \nabla v_*)v_* & \text{in } \Omega \setminus \{a_1, \dots, a_d\} \\ v_* = g & \text{on } \partial\Omega \end{cases}.$$

Here \mathcal{A} is the homogenized matrix of $a^2 \left(\frac{\cdot}{\delta}\right) \text{Id}_{\mathbb{R}^2}$ if $\lambda \equiv 1$ and $\mathcal{A} = \text{Id}_{\mathbb{R}^2}$ if $\lambda \rightarrow 0$.

In addition, for each $M > 0$, $v'_{\varepsilon,i}(\cdot) = v_\varepsilon\left(x_i^\varepsilon + \frac{\varepsilon}{b}\cdot\right)$ converges, up to a subsequence, in $C^1(B(0, M))$ to $f(|x|)\frac{x}{|x|}e^{i\theta_i}$ where $f: \mathbb{R}^+ \rightarrow \mathbb{R}^+$ is the universal function defined in [18] and $\theta_i \in \mathbb{R}$.

Theorem 4. Assume, in addition to the hypotheses of Theorem 3, that $\lambda \rightarrow 0$.

Let $[x] = [(x_1, x_2)] = ([x_1], [x_2]) \in \mathbb{Z}^2$ be the integer part of the point $x \in \mathbb{R}^2$.

For x_i^ε a zero of v_ε , let

$$\hat{x}_i^\varepsilon = \frac{\frac{x_i^\varepsilon}{\delta} - [\frac{x_i^\varepsilon}{\delta}]}{\lambda} \in \omega.$$

Then, as $\varepsilon \rightarrow 0$, up to pass to a subsequence, we have $x_i^\varepsilon \rightarrow \tilde{a}_i \in \omega$. Here, \tilde{a}_i minimizes a renormalized energy \tilde{W}_1 (given in [12] Eq. (90)) which depends only on ω and b . In particular, \tilde{a}_i is independent of the boundary condition g .

Theorem 5. Assume that λ, δ satisfy (1.3) and if the pinning term is not periodic (represented Figure 2) then we assume that $\lambda|\ln \delta| \rightarrow 0$.

Then

$$F_\varepsilon(v_\varepsilon) = J_{\varepsilon,\varepsilon} + db^2(\pi \ln b + \gamma) + o_\varepsilon(1)$$

where $J_{\varepsilon,\varepsilon}$ is defined in (3.6) and $\gamma > 0$ is the universal constant defined in [4] Lemma IX.1.

This article is divided in two parts:

- In the first one (Section 3) we consider two auxiliary minimization problems for weighted Dirichlet functionals associated to \mathbb{S}^1 -valued maps.
- The second part (Section 4) is devoted to the proofs of Theorems 1, 2, 3, 4, 5. The main tool is an η -ellipticity result (Lemma 11). This lemma reduces (under the assumption that λ, δ satisfy (1.3)) the study of F_ε to the one of the auxiliary problems considered in Section 3.

3 Shrinking holes for weighted Dirichlet functionals

This section is devoted to the study of three minimization problems.

The first and the third problems are related with minimizations of weighted Dirichlet functionals among \mathbb{S}^1 -valued maps. In both problems, the considered weights are the more general one: $\alpha \in L^\infty(\mathbb{R}^2, [b^2, 1])$. The second problem are stated with the weight $\alpha = U_\varepsilon^2$ in the situation where U_ε is the minimizer of E_ε in H_1^1 with a_ε given represented Figure 1 (the periodic case with or without dilution) or Figure 2 (the general diluted case).

Notation 1. In Section 3 we fix :

- a smooth and bounded open subset $\Omega' \prec \mathbb{R}^2$ s.t. $\overline{\Omega} \subset \Omega'$;
- a boundary condition $g \in C^\infty(\partial\Omega, \mathbb{S}^1)$ and we fix an extension of g which is in $H^1 \cap C^\infty(\Omega' \setminus \overline{\Omega}, \mathbb{S}^1)$. This extension is also denoted by g .
- we assume that $d := \deg_{\partial\Omega}(g) > 0$.

We will also consider (uniformly finite) families of points/degrees $\{(x_1, d_1), \dots, (x_N, d_N)\} = \{\mathbf{x}, \mathbf{d}\}$ s.t.

- $x_i \in \Omega$, $x_i \neq x_{i'}$ for $i \neq i'$;
- d_i are s.t. $d_i \in \mathbb{N}^*$ and $\sum_i d_i = d$.

According to the considered problems, for $0 < \rho \leq 8^{-1} \min_{i \neq i'} |x_i - x_{i'}|$ we will use the following perforated domains

- $\Omega_\rho := \Omega_\rho(\mathbf{x}) = \Omega \setminus \overline{\cup_i B(x_i, \rho)}$;
- $\Omega'_\rho := \Omega'_\rho(\mathbf{x}) = \Omega' \setminus \overline{\cup_i B(x_i, \rho)}$.

3.1 Existence results

In this subsection we prove the existence of solutions of two minimization problems whose studies will be the purpose of the rest of Section 3 (Subsections 3.2 and 3.3).

3.1.1 Existence of minimizing maps defined in a perforated domain

Let $\mathbf{x} = (x_1, \dots, x_N)$ be N distinct points of Ω and let $\mathbf{d} = (d_1, \dots, d_N) \in (\mathbb{N}^*)^N$ s.t. $\sum_i d_i = d$.

For $0 < \rho < 8^{-1} \min \{ \min_i \text{dist}(x_i, \partial\Omega), \min_i \text{dist}(x_i, \partial\Omega) \}$, we denote $\Omega_\rho = \Omega \setminus \overline{\cup_i B(x_i, \rho)}$. We define

$$\mathcal{I}_\rho(\mathbf{x}, \mathbf{d}) = \mathcal{I}_\rho := \left\{ w \in H^1(\Omega_\rho, \mathbb{S}^1) \mid w = g \text{ on } \partial\Omega \text{ and } \deg_{\partial B(x_i, \rho)}(w) = d_i \right\}$$

and

$$\mathcal{J}_\rho(\mathbf{x}, \mathbf{d}) = \mathcal{J}_\rho := \left\{ w \in H^1(\Omega_\rho, \mathbb{S}^1) \mid w = g \text{ on } \partial\Omega \text{ and } w(x_i + \rho e^{i\theta}) = e^{i(d_i\theta + \theta_i)} \right\}.$$

In Subsection 3.2, we compare the minimal energies corresponding to a weighted Dirichlet functional in the above sets. Here, we just state an existence results.

Proposition 2. *Let $\alpha \in L^\infty(\Omega)$ be s.t. $b^2 \leq \alpha \leq 1$. Consider the minimization problems*

$$\widehat{\mathcal{I}}_{\rho, \alpha}(\mathbf{x}, \mathbf{d}) = \inf_{w \in \mathcal{I}_\rho} \frac{1}{2} \int_{\Omega_\rho} \alpha |\nabla w|^2$$

and

$$\widehat{\mathcal{J}}_{\rho, \alpha}(\mathbf{x}, \mathbf{d}) = \inf_{w \in \mathcal{J}_\rho} \frac{1}{2} \int_{\Omega_\rho} \alpha |\nabla w|^2.$$

In both minimization problems the infima are attained.

Moreover, if $\alpha \in W^{1, \infty}(\Omega)$, then, denoting $w_{\rho, \alpha}^{\text{deg}}$ (resp. $w_{\rho, \alpha}^{\text{Dir}}$) a global minimizer of $\frac{1}{2} \int_{\Omega_\rho} \alpha |\nabla \cdot|^2$ in $\mathcal{I}_\rho(\mathbf{x}, \mathbf{d})$ (resp. in $\mathcal{J}_\rho(\mathbf{x}, \mathbf{d})$) we have $w_{\rho, \alpha}^{\text{deg}} \in H^2(\Omega_\rho, \mathbb{S}^1)$ (resp. $w_{\rho, \alpha}^{\text{Dir}} \in H^2(\Omega_\rho, \mathbb{S}^1)$) and

$$\begin{cases} -\text{div}(\alpha \nabla w_{\rho, \alpha}^{\text{deg}}) = \alpha |\nabla w_{\rho, \alpha}^{\text{deg}}|^2 w_{\rho, \alpha}^{\text{deg}} \text{ in } \Omega_\rho \\ w_{\rho, \alpha}^{\text{deg}} \in \mathcal{I}_\rho \text{ and } w_{\rho, \alpha}^{\text{deg}} \times \partial_\nu w_{\rho, \alpha}^{\text{deg}} = 0 \text{ on } \partial B(x_i, \rho) \end{cases}, \quad (3.1)$$

$$\begin{cases} -\text{div}(\alpha \nabla w_{\rho, \alpha}^{\text{Dir}}) = \alpha |\nabla w_{\rho, \alpha}^{\text{Dir}}|^2 w_{\rho, \alpha}^{\text{Dir}} \text{ in } \Omega_\rho \\ w_{\rho, \alpha}^{\text{Dir}} \in \mathcal{J}_\rho \text{ and } \int_{\partial B(x_i, \rho)} \alpha w_{\rho, \alpha}^{\text{Dir}} \times \partial_\nu w_{\rho, \alpha}^{\text{Dir}} = 0 \end{cases}. \quad (3.2)$$

The proof of this standard result is postponed to Appendix A.

In the special case $\alpha = U_\varepsilon^2$, we denote

$$\widehat{\mathcal{I}}_{\rho, \varepsilon}(\mathbf{x}, \mathbf{d}) = \inf_{w \in \mathcal{I}_\rho} \frac{1}{2} \int_{\Omega_\rho} U_\varepsilon^2 |\nabla w|^2 \text{ and } \widehat{\mathcal{J}}_{\rho, \varepsilon}(\mathbf{x}, \mathbf{d}) = \inf_{w \in \mathcal{J}_\rho} \frac{1}{2} \int_{\Omega_\rho} U_\varepsilon^2 |\nabla w|^2.$$

3.1.2 Existence of an optimal perforated domain

For $\alpha \in L^\infty(\mathbb{R}^2, [b^2, 1])$ we define

$$I_{\rho,\alpha} := \inf_{\substack{x_1, \dots, x_N \in \Omega \\ |x_i - x_j| \geq 8\rho \\ d_1, \dots, d_N > 0, \sum d_i = d}} \inf_{\substack{w \in H_g^1(\Omega'_\rho, \mathbb{S}^1) \\ \deg_{\partial B(x_i, \rho)}(w) = d_i}} \frac{1}{2} \int_{\Omega'_\rho} \alpha |\nabla w|^2 \quad (3.3)$$

and

$$J_{\rho,\alpha} := \inf_{\substack{x_1, \dots, x_d \in \Omega \\ |x_i - x_j| \geq 8\rho \\ \text{dist}(x_i, \partial\Omega) \geq 8\rho}} \inf_{\substack{w \in H_g^1(\Omega_\rho, \mathbb{S}^1) \\ w(x_i + \rho e^{i\theta}) = e^{i(\theta + \theta_i)}, \theta_i \in \mathbb{R}}} \frac{1}{2} \int_{\Omega_\rho} \alpha |\nabla w|^2. \quad (3.4)$$

Here $\Omega'_\rho = \Omega' \setminus \overline{\cup B(x_i, \rho)}$.

In the special case $\alpha = U_\varepsilon^2$, we denote

$$I_{\rho,\varepsilon} := \inf_{\substack{x_1, \dots, x_N \in \Omega \\ |x_i - x_j| \geq 8\rho \\ d_1, \dots, d_N > 0, \sum d_i = d}} \inf_{\substack{w \in H_g^1(\Omega'_\rho, \mathbb{S}^1) \\ \deg_{\partial B(x_i, \rho)}(w) = d_i}} \frac{1}{2} \int_{\Omega'_\rho} U_\varepsilon^2 |\nabla w|^2 \quad (3.5)$$

and

$$J_{\rho,\varepsilon} := \inf_{\substack{x_1, \dots, x_d \in \Omega \\ |x_i - x_j| \geq 8\rho \\ \text{dist}(x_i, \partial\Omega) \geq 8\rho}} \inf_{\substack{w \in H_g^1(\Omega_\rho, \mathbb{S}^1) \\ w(x_i + \rho e^{i\theta}) = e^{i(\theta + \theta_i)}, \theta_i \in \mathbb{R}}} \frac{1}{2} \int_{\Omega_\rho} U_\varepsilon^2 |\nabla w|^2. \quad (3.6)$$

We have the following result

Proposition 3. *For $\alpha \in L^\infty(\mathbb{R}^2, [b^2, 1])$, there are $\mathbf{x}_{\rho,\alpha}^{\text{deg}}, \mathbf{x}_{\rho,\alpha}^{\text{Dir}} \in \Omega^d$ and $\mathbf{d}_{\rho,\alpha} = (d_1, \dots, d_N) \in (\mathbb{N}^*)^N$ (with $\sum d_i = d$) s.t. $\{\mathbf{x}_{\rho,\alpha}^{\text{deg}}, \mathbf{d}_{\rho,\alpha}\}$ minimizes $I_{\rho,\alpha}$ and $\mathbf{x}_{\rho,\alpha}^{\text{Dir}}$ minimizes $J_{\rho,\alpha}$.*

The proof of this result is in Appendix B.

3.2 Dirichlet Vs Degree Conditions in a fixed perforated domain

Let $\eta_{\text{stop}} > 0$ be s.t. $\eta_{\text{stop}} < 10^{-5} \cdot 9^{-d^2} \text{diam}(\Omega)$.

Consider $x_1, \dots, x_N \in \Omega$, $d \geq N \geq 1$ distinct points of Ω satisfying the condition $\eta_{\text{stop}} < 10^{-3} \cdot 9^{-d^2} \min \text{dist}(x_i, \partial\Omega)$, and let $\rho > 0$ be s.t. $\min \{\eta_{\text{stop}}, \min_{i \neq j} |x_i - x_j|\} > 8\rho$. Roughly speaking η_{stop} controls the distance between the points and $\partial\Omega$.

The main result of this section is

Proposition 4. *There is $C_0 > 0$ depending only on $g, \Omega, \eta_{\text{stop}}$ and b s.t. for $\alpha \in L^\infty(\Omega, [b^2, 1])$ we have*

$$\widehat{\mathcal{I}}_{\rho,\alpha}(\mathbf{x}, \mathbf{d}) \leq \widehat{\mathcal{J}}_{\rho,\alpha}(\mathbf{x}, \mathbf{d}) \leq \widehat{\mathcal{I}}_{\rho,\alpha}(\mathbf{x}, \mathbf{d}) + C_0.$$

Here, $\widehat{\mathcal{I}}_{\rho,\alpha}$ and $\widehat{\mathcal{J}}_{\rho,\alpha}$ are defined Proposition 2.

The rigorous proof of Proposition 4 is presented in Appendix C.

Here, we simply present the main lines of the proof.

Two situations are possible:

1. $N = 1$ or the points x_1, \dots, x_N are well separated: $\frac{1}{4} \min_{i \neq j} |x_i - x_j| > \eta_{\text{stop}}$,
2. The points x_1, \dots, x_N are not well separated: $\frac{1}{4} \min_{i \neq j} |x_i - x_j| \leq \eta_{\text{stop}}$.

If the points are well separated (or $N = 1$), Proposition 4 can be easily proved: it is a direct consequence of Proposition 29 and Lemma 28 in Appendix C.

Indeed the proof is made in three steps:

Step 1: Using Lemma 28, we obtain a constant C_1 (depending only on $g, \Omega, \eta_{\text{stop}}$) s.t.

$$\widehat{\mathcal{J}}_{10^{-1}\eta_{\text{stop}}, \alpha}(\mathbf{x}, \mathbf{d}) \leq C_1.$$

Step 2: With the help of Proposition 29, we obtain the existence of a constant C_b (depending only on b) s.t. for $\tilde{d} \in \mathbb{N}$, denoting $A_\rho^i = B(x_i, 10^{-1}\eta_{\text{stop}}) \setminus \overline{B(x_i, \rho)}$, we have

$$\inf_{\substack{w \in H^1(A_\rho^i, \mathbb{S}^1) \\ w(x_1 + 10^{-1}\eta_{\text{stop}}e^{i\theta}) = C_{\text{st}1}e^{i\tilde{d}\theta} \\ w(x_1 + \rho e^{i\theta}) = C_{\text{st}2}e^{i\tilde{d}\theta}}} \frac{1}{2} \int_{A_\rho^i} \alpha |\nabla w|^2 \leq \inf_{\substack{w \in H^1(A_\rho^i, \mathbb{S}^1) \\ \deg_{\partial B(x_i, \rho)}(w) = \tilde{d}}} \frac{1}{2} \int_{A_\rho^i} \alpha |\nabla w|^2 + C_b \tilde{d}^2.$$

Step 3: By extending a minimizer of $\widehat{\mathcal{J}}_{10^{-1}\eta_{\text{stop}}, \alpha}(\mathbf{x}, \mathbf{d})$ by the ones of $\frac{1}{2} \int_{A_\rho^i} \alpha |\nabla \cdot|^2$ with Dirichlet conditions, we can construct a map which proves the result taking $C_0 = C_1 + d^3 C_b$.

3.3 Optimal perforated domains for the degree conditions

Consider $\Omega' \supset \Omega$ a smooth bounded domain s.t. $\text{dist}(\partial\Omega', \Omega) > 0$ and a smooth \mathbb{S}^1 -valued extension of g to $\Omega' \setminus \overline{\Omega}$ (still denoted by g).

In this section, we study the minimization problem

$$I_{\rho, \varepsilon} := \inf_{\substack{x_1, \dots, x_N \in \Omega \\ |x_i - x_j| \geq 8\rho \\ d_1, \dots, d_N > 0, \sum d_i = d}} \inf_{\substack{w \in H_g^1(\Omega'_\rho, \mathbb{S}^1) \\ \deg_{\partial B(x_i, \rho)}(w) = d_i}} \frac{1}{2} \int_{\Omega'_\rho} U_\varepsilon^2 |\nabla w|^2 \quad (3.7)$$

where

$$\Omega'_\rho = \Omega' \setminus \overline{\cup B(x_i, \rho)}$$

and

$$H_g^1(\Omega'_\rho, \mathbb{S}^1) = \left\{ w \in H^1(\Omega'_\rho, \mathbb{S}^1) \mid w = g \text{ in } \Omega' \setminus \overline{\Omega \cup \cup B(x_i, \rho)} \right\};$$

here, we extended U_ε with the value 1 outside Ω . We recall that we denoted by U_ε **the** unique global minimizer of E_ε in H_1^1 .

In this subsection we assume that Hypothesis (1.3) holds ($|\ln(\lambda\delta)|^3 / |\ln \varepsilon| \rightarrow 0$). This is not optimal for the statements but it makes the proofs simpler (this hypothesis may be relaxed in this Section, but it appears as a crucial and technical hypothesis for the methods developed Section 4).

A first purpose of this section is the study of the behavior of $I_{\rho, \varepsilon}$ when $\rho = \rho(\varepsilon) \rightarrow 0$ as $\varepsilon \rightarrow 0$. In view of the application we have in mind we suppose that $\lambda\delta^{P+1} \gg \rho(\varepsilon) \geq \varepsilon$ but this is not crucial for our arguments (here $P = 1$ if U_ε is associated with the periodic pinning term).

A second objective of our study is to exhibit the behavior of almost minimizing configurations $\{(x_1^n, \dots, x_N^n), (d_1^n, \dots, d_N^n)\}$.

For fixed ρ, ε , the existence of a minimizing configuration of points $\mathbf{x}_{\rho, \varepsilon}$ is the purpose of Proposition 3. In this section we consider only almost minimizing configurations.

Notation 2. For $\varepsilon_n \downarrow 0$, we say that $\{(x_1^n, \dots, x_N^n), (d_1^n, \dots, d_N^n)\}$ is an almost minimizing configuration for $\rho = \rho(\varepsilon_n) \downarrow 0$ when $x_1^n, \dots, x_N^n \in \Omega$, $|x_i^n - x_j^n| \geq 8\rho$, $d_1^n, \dots, d_N^n > 0$, $\sum d_i^n = d$ and there is $C > 0$ (independent of n) s.t.

$$\inf_{\substack{w \in H_g^1(\Omega'_\rho, \mathbb{S}^1) \\ \deg_{\partial B(x_i^n, \rho)}(w) = d_i^n}} \frac{1}{2} \int_{\Omega'_\rho} U_{\varepsilon_n}^2 |\nabla w|^2 - I_{\rho, \varepsilon_n} \leq C.$$

Roughly speaking, we prove in this section two repelling effects for the points: point/point and point/ $\partial\Omega$; and an attractive effect for the points due to the inclusions ω_ε .

3.3.1 The case of the periodic pinning term

The main result of this section establishes that when $\varepsilon_n, \rho \downarrow 0$, an almost minimizing configuration $\{(x_1^n, \dots, x_N^n), (d_1^n, \dots, d_N^n)\}$ is s.t.

- the points x_i^n 's cannot be mutually close,
- the degrees d_i^n 's are necessarily all equal to 1,
- the points x_i^n 's cannot approach $\partial\Omega$,
- there is $c > 0$ s.t., for large n , $B(x_i^n, c\lambda\delta) \subset \omega_\varepsilon$ for all i .

These facts are expressed in the following proposition (whose proof is postponed to Appendix D).

Proposition 5. *[The case of a periodic pinning term]*

Assume that λ, δ satisfy (1.3) and let a_ε be the periodic the pinning term (represented Figure 1).

Let $\varepsilon_n \downarrow 0$, $\rho = \rho(\varepsilon_n) \downarrow 0$, $x_1^n, \dots, x_N^n \in \Omega$ be s.t. $|x_i^n - x_j^n| \geq 8\rho$, $\rho \geq \varepsilon_n$ and let $d_1^n, \dots, d_N^n \in \mathbb{N}^*$ be s.t. $\sum d_i^n = d$.

1. Assume that there is $i_0 \in \{1, \dots, N\}$ s.t. $d_{i_0}^n \neq 1$ or that there are $i_0 \neq j_0$ s.t. $|x_{i_0}^n - x_{j_0}^n| \rightarrow 0$. Then

$$\inf_{\substack{w \in H_g^1(\Omega'_\rho, \mathbb{S}^1) \\ \deg_{\partial B(x_i^n, \rho)}(w) = d_i^n}} \left\{ \frac{1}{2} \int_{\Omega'_\rho} U_{\varepsilon_n}^2 |\nabla w|^2 - I_{\rho, \varepsilon_n} \right\} \rightarrow \infty.$$

2. Assume that there is $i_0 \in \{1, \dots, N\}$ s.t. $\text{dist}(x_{i_0}^n, \partial\Omega) \rightarrow 0$. Then

$$\inf_{\substack{w \in H_g^1(\Omega'_\rho, \mathbb{S}^1) \\ \deg_{\partial B(x_i^n, \rho)}(w) = d_i^n}} \left\{ \frac{1}{2} \int_{\Omega'_\rho} U_{\varepsilon_n}^2 |\nabla w|^2 - I_{\rho, \varepsilon_n} \right\} \rightarrow \infty.$$

3. Assume that $\frac{\rho}{\lambda\delta} \rightarrow 0$ and that there is $i_0 \in \{1, \dots, N\}$ s.t. $x_{i_0}^n \notin \omega_\varepsilon$ or s.t. $x_{i_0}^n \in \omega_\varepsilon$ and $\frac{\text{dist}(x_{i_0}^n, \partial\omega_\varepsilon)}{\lambda\delta} \rightarrow 0$. Then

$$\inf_{\substack{w \in H_g^1(\Omega'_\rho, \mathbb{S}^1) \\ \deg_{\partial B(x_i^n, \rho)}(w) = d_i^n}} \left\{ \frac{1}{2} \int_{\Omega'_\rho} U_{\varepsilon_n}^2 |\nabla w|^2 - I_{\rho, \varepsilon_n} \right\} \rightarrow \infty.$$

A straightforward consequence of Proposition 5 is the following

Corollary 6. 1. Consider an almost minimal configuration $(\mathbf{x}_{\rho,\varepsilon}, \mathbf{d}_{\rho,\varepsilon}) \in \Omega^N \times \mathbb{N}^{*N}$, i.e., assume that there is $w_{\rho,\varepsilon} \in H_g^1(\Omega' \setminus \cup B(x_i^{\rho,\varepsilon}, \rho), \mathbb{S}^1)$ verifying

$$\deg_{\partial B(x_i^{\rho,\varepsilon}, \rho)}(w) = d_i^{\rho,\varepsilon} \text{ and } \frac{1}{2} \int_{\Omega' \setminus \cup B(x_i^{\rho,\varepsilon}, \rho)} U_\varepsilon^2 |\nabla w|^2 \leq I_{\rho,\varepsilon} + C.$$

(Here, C is independent of ε .)

Then, there is some η_0 depending only on C s.t., for small ε , we have

$$|x_i^{\rho,\varepsilon} - x_j^{\rho,\varepsilon}|, \text{dist}(x_i^{\rho,\varepsilon}, \partial\Omega) \geq \eta_0 \text{ and } d_i = 1 \text{ for all } i \neq j, i, j \in \{1, \dots, N\}.$$

In particular, we have $N = d$.

2. If, in addition, $\rho = \rho(\varepsilon)$ is s.t. $\rho \geq \varepsilon$ and $\frac{\rho}{\lambda\delta} \rightarrow 0$, then there is $c > 0$ (independent of ε) s.t., for small ε , we have $B(x_i^{\rho,\varepsilon}, c\lambda\delta) \subset \omega_\varepsilon$.

Proof. We prove the first part. Let $C > 0$. We argue by contradiction and we assume that for all $n \in \mathbb{N}^*$ there are $0 < \varepsilon_n \leq \rho = \rho(\varepsilon_n) \leq 1/n$, $\mathbf{x}_n = \mathbf{x}_{\rho,\varepsilon_n}$, (d_1, \dots, d_N) and $w_n = w_{\rho,\varepsilon_n}$ satisfying the hypotheses of Corollary 6 and s.t.

$$\min \{|x_i^n - x_j^n|, \text{dist}(x_i^n, \partial\Omega)\} \rightarrow 0 \text{ or s.t. there is } i \in \{1, \dots, N\} \text{ for which we have } d_i \neq 1.$$

By construction we have that $(\mathbf{x}_{\rho,\varepsilon_n}, \mathbf{d})$ is an almost minimizing configuration for I_{ρ,ε_n} with $\rho = \rho(\varepsilon_n) \geq \varepsilon_n$. Clearly from Proposition 5 we find a contradiction.

The proof of the second part is similar. \square

We end this subsection by the following direct consequence of Corollary 6

Corollary 7. For sufficiently small ε, ρ , an almost minimizing configuration (x_1, \dots, x_d) for $J_{\rho,\varepsilon}$ is an almost minimizing configuration for $I_{\rho,\varepsilon}$.

Moreover, there is $C_0 > 0$ s.t. $J_{\rho,\varepsilon} \leq I_{\rho,\varepsilon} + C_0$, C_0 is independent of small ε, ρ .

Proof. Let $C \geq 0$ and let $(x_1, \dots, x_d), (x'_1, \dots, x'_d) \in \Omega^d$ be s.t.

$$\hat{\mathcal{J}}_{\rho,\varepsilon}(x_1, \dots, x_d) \leq J_{\rho,\varepsilon} + C$$

and

$$\hat{\mathcal{I}}_{\rho,\varepsilon}(x'_1, \dots, x'_d) \leq I_{\rho,\varepsilon} + C.$$

From Corollary 6, there is $\eta_0 = \eta_0(C) > 0$ s.t. for $\varepsilon \leq \rho \leq \eta_0$, $\min_i \text{dist}(x'_i, \partial\Omega) \geq \eta_0$. Using Proposition 4 we find the existence of C_0 s.t.

$$\begin{aligned} \hat{\mathcal{I}}_{\rho,\varepsilon}(x_1, \dots, x_d) \leq \hat{\mathcal{J}}_{\rho,\varepsilon}(x_1, \dots, x_d) &\leq J_{\rho,\varepsilon} + C \leq \hat{\mathcal{J}}_{\rho,\varepsilon}(x'_1, \dots, x'_d) + C \\ &\leq \hat{\mathcal{I}}_{\rho,\varepsilon}(x'_1, \dots, x'_d) + C + C_0 \\ &\leq I_{\rho,\varepsilon} + 2C + C_0. \end{aligned}$$

\square

3.3.2 A more precise result for the case of the periodic pinning term with dilution

In this section we focus on the periodic pinning term (represented Figure 1) with dilution: $\lambda \rightarrow 0$.

Notation 3. We define two kinds of configuration of distinct points of Ω :

- We say that for $\varepsilon_n \downarrow 0$ and $\rho = \rho(\varepsilon_n) \rightarrow 0$, d distinct points of Ω , $\mathbf{x}_n = (x_1^n, \dots, x_d^n)$ form a quasi-minimizer of J_{ρ, ε_n} when $\mathcal{J}_{\rho, \varepsilon_n}(\mathbf{x}_n) - J_{\rho, \varepsilon_n} \rightarrow 0$.
- We say that for $\varepsilon_n \downarrow 0$ and $\rho = \rho(\varepsilon_n) \rightarrow 0$, d distinct points of Ω , $\mathbf{x}_n = (x_1^n, \dots, x_d^n)$ form a quasi-minimizer of W_g , the *renormalized energy* of Bethuel-Brezis-Hélein (see [4]) when $W_g(\mathbf{x}_n) \rightarrow \min W_g$.

Proposition 8. *[Exact location of optimal perforations]*

Assume that λ, δ satisfy (1.3) and that $\lambda \rightarrow 0$.

Let $\varepsilon_n \downarrow 0$, $\rho = \rho(\varepsilon_n) \rightarrow 0$, $\rho \geq \varepsilon_n$ and $\mathbf{x}_n = (x_1^n, \dots, x_d^n)$ be d distinct points of Ω .

If the points \mathbf{x}_n form a quasi-minimizer of J_{ρ, ε_n} , then $\mathbf{x}_n = (x_1^n, \dots, x_d^n)$ form a quasi-minimizer of W_g .

This proposition is proved Appendix E.

3.3.3 The case of a general pinning with variable sizes of inclusions

We assume that a_ε is the general pinning term represented Figure 2. We add a hypothesis on the dilution: $\lambda |\ln \delta| \rightarrow 0$.

Proposition 9. *[The case of a non-periodic pinning term]*

Assume that λ, δ satisfy (1.3) and $\lambda |\ln \delta| \rightarrow 0$.

Let $\rho = \rho(\varepsilon)$ s.t. $\rho \geq \varepsilon$ and $\frac{\rho}{\lambda \delta^{3/2}} \rightarrow 0$. If $(\mathbf{x}_{\rho, \varepsilon}, \mathbf{d}_{\rho, \varepsilon}) \in \Omega^N \times \mathbb{N}^{*N}$ is an almost minimal configuration for $I_{\rho, \varepsilon}$, then $N = d$ (thus $d_i = 1$ for all i) and there are $c, \eta_0 > 0$ s.t. for sufficiently small ε :

1. $|x_i^{\rho, \varepsilon} - x_j^{\rho, \varepsilon}|, \text{dist}(x_i^{\rho, \varepsilon}, \partial\Omega) \geq \eta_0$ for all $i \neq j, i, j \in \{1, \dots, N\}$.
2. $B(x_i^{\rho, \varepsilon}, c\lambda\delta) \subset \cup_{l \in \mathcal{M}_1^\varepsilon} y_{l,1}^\varepsilon + \lambda\delta \cdot \omega$ (the centers of the holes are included in the largest inclusions).

Moreover, there is $C_0 > 0$ s.t. $J_{\rho, \varepsilon} \leq I_{\rho, \varepsilon} + C_0$, C_0 is independent of small ε, ρ . And thus an almost minimizing configuration $\mathbf{x}_{\rho, \varepsilon}$ for $J_{\rho, \varepsilon}$ is an almost minimizing configuration for $I_{\rho, \varepsilon}$.

This proposition is proved Appendix E.

4 The pinned Ginzburg-Landau functional

In this section, we turn to the study of minimizers of (1.1) in H_g^1 . The pinning term is the periodic one (represented Figure 1) or the non periodic one (represented Figure 2).

Recall that we fix $\delta = \delta(\varepsilon)$, $\delta \rightarrow 0$, $\lambda = \lambda(\varepsilon)$, $\lambda \equiv 1$ or $\lambda \rightarrow 0$ satisfying (1.3). If the pinning term is not periodic then we add the hypothesis $\lambda |\ln \delta| \rightarrow 0$.

4.1 Sharp Upper Bound, η -ellipticity and Uniform Convergence

4.1.1 Sharp Upper Bound and an η -ellipticity result

We may easily prove the following upper bound.

Lemma 10. *There is a constant C independent of ε s.t., for $1 \geq \lambda\delta \geq \rho \geq \varepsilon > 0$, we have*

$$\inf_{v \in H_g^1(\Omega, \mathbb{C})} F_\varepsilon(v, \Omega) \leq db^2 \pi \ln \frac{\rho}{\varepsilon} + J_{\rho, \varepsilon} + C. \quad (4.1)$$

If, in addition, we assume that $\frac{\rho}{\lambda\delta} \rightarrow 0$ (or $\frac{\rho}{\lambda\delta^{3/2}} \rightarrow 0$ if the pinning term is not periodic), then we have for ε sufficiently small

$$\inf_{v \in H_g^1(\Omega, \mathbb{C})} F_\varepsilon(v, \Omega) \leq db^2 \left(\pi \ln \frac{b\rho}{\varepsilon} + \gamma \right) + J_{\rho, \varepsilon}, \quad (4.2)$$

where $\gamma > 0$ is a universal constant defined in [4], Lemma IX.1.

Proof. From Proposition 3, one may consider $(x_1^\varepsilon, \dots, x_d^\varepsilon) = \mathbf{x}^\varepsilon \in \Omega^d$, a minimizing configuration for $J_{\rho, \varepsilon}$.

Note that if $\frac{\rho}{\lambda\delta} \rightarrow 0$, then, for small ε , from Corollaries 6 and 7 (or Proposition 9 if the pinning term is not periodic), there are $\eta > 0$ and $c > 0$ s.t. $B(x_i^\varepsilon, c\lambda\delta) \subset \omega_\varepsilon$ and $\min_i \{ \min_{i \neq j} |x_i - x_j|, \text{dist}(x_i, \partial\Omega) \} \geq \eta$.

Assume that $\frac{\rho}{\lambda\delta} \rightarrow 0$ and let w_ε be a minimizing map in $\mathcal{J}_{\rho, \varepsilon}(\mathbf{x}^\varepsilon, (1, \dots, 1))$.

Consider $u_{\varepsilon/(b\rho)}$, the global minimizer of

$$E_{\varepsilon/(b\rho)}^0(u) = \frac{1}{2} \int_{B(0,1)} \left\{ |\nabla u|^2 + \frac{b^2 \rho^2}{2\varepsilon^2} (1 - |u|^2)^2 \right\}, \quad u \in H_{x/|x|}^1(B(0,1), \mathbb{C}).$$

We consider the test function

$$w_\varepsilon(x) = \begin{cases} w_\varepsilon & \text{in } \Omega_\rho \\ \alpha_i u_{\varepsilon/(b\rho)} \left(\frac{x - x_i^\varepsilon}{\rho} \right) & \text{in } B(x_i^\varepsilon, \rho) \end{cases}.$$

Estimate (4.2) is obtained by using the fact that $E_\varepsilon^0(u_\varepsilon) = \pi |\ln \varepsilon| + \gamma + o_\varepsilon(1)$ as $\varepsilon \rightarrow 0$ (see [4] Lemma IX.1) and Proposition 1.

In the situation where $\frac{\rho}{\lambda\delta} \not\rightarrow 0$, we may assume that $\frac{\rho}{\lambda\delta} \geq C_0 > 0$. We can replace the minimal configuration \mathbf{x}^ε by a configuration \mathbf{y}^ε s.t. there is $C > 0$ independent of ε satisfying

$$y_i^\varepsilon \in \omega_\varepsilon \cap \delta \cdot (\mathbb{Z} \times \mathbb{Z}) \text{ and } \hat{\mathcal{J}}_{\rho, \varepsilon}(\mathbf{x}, (1, \dots, 1)) \leq J_{\rho, \varepsilon} + C.$$

We consider the test function

$$w_\varepsilon = \begin{cases} \text{a minimizer of } \mathcal{J}_{\rho, \varepsilon}(\mathbf{y}^\varepsilon, (1, \dots, 1)) & \text{in } \Omega \setminus \overline{\cup B(y_i^\varepsilon, \rho)} \\ \alpha_i \frac{x - y_i^\varepsilon}{\rho} & \text{in } B(y_i^\varepsilon, \rho) \end{cases}.$$

A direct computation shows that (4.1) holds. \square

Note that

$$I_{\rho,\varepsilon} \leq J_{\rho,\varepsilon} \leq \pi d |\ln \rho| + C. \quad (4.3)$$

We now turn to the η -ellipticity.

We denote by v_ε a global minimizer of F_ε in H_g^1 . We extend $|v_\varepsilon|$ with the value 1 outside Ω .

One of the main ingredients in this work is the following result.

Lemma 11. [*η -ellipticity Lemma*]

Let $0 < \alpha < 1/2$. Then the following results hold:

1. If for $\varepsilon < \varepsilon_0$

$$F_\varepsilon(v_\varepsilon, B(x, \varepsilon^\alpha) \cap \Omega) \leq \chi^2 |\ln \varepsilon| - C_1,$$

then we have

$$|v_\varepsilon| \geq 1 - C\chi \text{ in } B(x, \varepsilon^{2\alpha}).$$

Here, $\chi_\varepsilon \in (0, 1)$ is s.t. $\chi_\varepsilon \rightarrow 0$ and $\varepsilon_0 > 0$, $C > 0$, $C_1 > 0$ depend only on $b, \alpha, \chi, \Omega, \|g\|_{C^1(\partial\Omega)}$.

2. If for $\varepsilon < \varepsilon_0$

$$F_\varepsilon(v_\varepsilon, B(x, \varepsilon^\alpha) \cap \Omega) \leq C |\ln \varepsilon|,$$

then we have

$$|v_\varepsilon| \geq \mu \text{ in } B(x, \varepsilon^{2\alpha}).$$

Here, $\mu \in (0, 1)$ and $\varepsilon_0, C > 0$ depend only on $b, \alpha, \mu, \Omega, \|g\|_{C^1(\partial\Omega)}$.

This result is a direct consequence of Lemma 1 in [12].

4.1.2 Uniform convergence to 1 of $|\hat{v}_\varepsilon|$ in $\mathbb{R}^2 \setminus K$, K closed set, $\bar{\omega} \in K$

With the help of Lemma 11, we are in position to establish uniform convergence of $|v_\varepsilon|$ to 1 far away from $\bar{\omega}_\varepsilon$.

Proposition 12. Let $10^{-2} \cdot \text{dist}(\omega, \partial Y) > \mu > 0$ and $K_\varepsilon^\mu = \{x \in \Omega \mid \text{dist}(x, \omega_\varepsilon) \geq \mu\lambda\delta\}$. Then, for sufficiently small ε , we have

$$|v_\varepsilon| \geq 1 - C \sqrt{\frac{|\ln(\lambda\delta)|}{|\ln \varepsilon|}} \text{ in } K_\varepsilon^\mu.$$

Here C is independent of ε and μ .

Furthermore, if for some small ε , we have $|v_\varepsilon(x)| < 1 - C \sqrt{\frac{|\ln(\lambda\delta)|}{|\ln \varepsilon|}}$, then

$$F_\varepsilon(v_\varepsilon, B(x, \varepsilon^{1/4})) \geq \frac{\pi d + 1}{b^2(1 - b^2)} |\ln(\lambda\delta)|.$$

Proof. Using Lemma 11 Part 1. with $\alpha = 1/4$ and with $\chi = \sqrt{\frac{\pi d + 1}{b^2(1 - b^2)} \frac{|\ln(\lambda\delta)|}{|\ln \varepsilon|}}$, we obtain the existence of $C > 0$ s.t. for $\varepsilon > 0$ sufficiently small:

if $F_\varepsilon(v_\varepsilon, B(x, \varepsilon^{1/4})) < \frac{\pi d + 1}{b^2(1 - b^2)} |\ln(\lambda\delta)|$, then we have $|v_\varepsilon| \geq 1 - C\chi$ in $B(x, \varepsilon^{1/2})$.

In order to prove Proposition 12, we argue by contradiction. There are $\varepsilon_n \downarrow 0$, $\mu > 0$ and $x_n \in K_\varepsilon^\mu$ s.t.

$$|v_{\varepsilon_n}(x_n)| < 1 - C\chi.$$

From (1.5), we find

$$|U_{\varepsilon_n} - 1| \leq C e^{-\frac{\alpha\mu}{2\xi}} \text{ in } K_{\varepsilon_n}^{\mu/2}. \quad (4.4)$$

Consequently, Lemma 11, the definition of C and (4.4) imply that for large n ,

$$\frac{1}{2} \int_{B(x_n, \varepsilon_n^{1/4})} \left\{ |\nabla v_{\varepsilon_n}|^2 + \frac{1}{2\varepsilon_n^2} (1 - |v_{\varepsilon_n}|^2)^2 \right\} \geq \frac{\pi d + 1}{b^2(1 - b^2)} |\ln(\lambda\delta)| + o_\varepsilon(1). \quad (4.5)$$

We extend v_ε to $\Omega' := \Omega + B(0, 1)$ with the help of a fixed smooth \mathbb{S}^1 -valued map v s.t. $v = g$ on $\partial\Omega$. We also extend U_ε and a_ε with the value 1 outside Ω .

For n sufficiently large, we have

$$\frac{1}{2} \int_{\Omega'} \left\{ |\nabla v_{\varepsilon_n}|^2 + \frac{1}{2\varepsilon_n^2} (1 - |v_{\varepsilon_n}|^2)^2 \right\} \leq C |\ln \varepsilon_n|.$$

Theorem 4.1 in [19] applied with $r = 10^{-2}\lambda\delta\mu$ and for large n , implies the existence of $\mathcal{B}^n = \{B_j^n\}$ a finite disjoint covering by balls of

$$\left\{ x \in \Omega' \mid \text{dist}(x, \partial\Omega') > \frac{\varepsilon_n}{b} \text{ and } 1 - |v_{\varepsilon_n}(x)| \geq \left(\frac{\varepsilon_n}{b}\right)^{1/8} \right\}$$

s.t.

$$\text{rad}(\mathcal{B}^n) \leq 10^{-2} \cdot \lambda\delta\mu$$

satisfying

$$\begin{aligned} \frac{1}{2} \int_{\cup B_j^n} \left\{ |\nabla v_{\varepsilon_n}|^2 + \frac{b^2}{2\varepsilon_n^2} (1 - |v_{\varepsilon_n}|^2)^2 \right\} &\geq \pi \sum_j d_j^n (|\ln \varepsilon_n| - |\ln(\lambda\delta)|) - C \\ &= \pi \sum_j d_j^n |\ln \xi| - C. \end{aligned}$$

Here, $\text{rad}(\mathcal{B}^n) = \sum_i \text{rad}(B_j^n)$, $\text{rad}(B)$ stands for the radius of the ball B , $\xi = \varepsilon_n/(\lambda\delta)$ and the integers d_j^n are defined by

$$d_j^n = \begin{cases} |\text{deg}_{\partial B_j^n}(v_{\varepsilon_n})| & \text{if } B_j^n \subset \{x \in \Omega' \mid \text{dist}(x, \partial\Omega') > \frac{\varepsilon_n}{b}\} \\ 0 & \text{otherwise} \end{cases}.$$

Since $B_j \subset \Omega + B_{1/2} \subset \{x \in \Omega' \mid \text{dist}(x, \partial\Omega') > \frac{\varepsilon_n}{b}\}$, we obtain

$$\frac{1}{2} \int_{\cup B_j^n} \left\{ |\nabla v_{\varepsilon_n}|^2 + \frac{b^2}{2\varepsilon_n^2} (1 - |v_{\varepsilon_n}|^2)^2 \right\} \geq \pi d |\ln \xi| - C. \quad (4.6)$$

From (4.4) and (1.3) we have

$$\begin{aligned} F_\xi(v_{\varepsilon_n}, \cup_j B_j \cup B(x_n, \varepsilon_n^{1/4})) &\geq \frac{b^2(1 - b^2)}{2} \int_{B(x_n, \varepsilon_n^{1/4})} \left\{ |\nabla v_{\varepsilon_n}|^2 + \frac{1}{2\varepsilon_n^2} (1 - |v_{\varepsilon_n}|^2)^2 \right\} + \\ &+ \frac{b^2}{2} \int_{\cup_j B_j} \left\{ |\nabla v_{\varepsilon_n}|^2 + \frac{b^2}{2\varepsilon_n^2} (1 - |v_{\varepsilon_n}|^2)^2 \right\} + o_n(1). \end{aligned} \quad (4.7)$$

By combining (4.1), (4.3), (4.5), (4.6) and (4.7), we find that

$$\begin{aligned} \pi db^2 |\ln \xi| + \pi d |\ln(\lambda\delta)| &\geq F_{\varepsilon_n}(v_{\varepsilon_n}, \Omega') - \mathcal{O}_n(1) \\ &\geq F_{\varepsilon_n}(v_{\varepsilon_n}, \cup_j B_j \cup B(x_n, \varepsilon_n^{1/4})) - \mathcal{O}_n(1) \\ &\geq \pi db^2 |\ln \xi| + (\pi d + 1) |\ln(\lambda\delta)| - \mathcal{O}_n(1), \end{aligned}$$

which is a contradiction. This completes the proof of Proposition 12. \square

4.2 Bad discs

4.2.1 Construction and first properties of bad discs

Consider a family of discs $(B(x_i, \varepsilon^{1/4}))_{i \in I}$ s.t

$$x_i \in \Omega, \forall i \in I,$$

$$B(x_i, \varepsilon^{1/4}/4) \cap B(x_j, \varepsilon^{1/4}/4) = \emptyset \text{ if } i \neq j,$$

$$\cup_{i \in I} B(x_i, \varepsilon^{1/4}) \supset \Omega.$$

Let $C_0 = C_0(1/4, 7/8)$, $\varepsilon_0 = \varepsilon_0(1/4, 7/8)$ be defined by as in Lemma 11.2. For $\varepsilon < \varepsilon_0$, we say that $B(x_i, \varepsilon^{1/4})$ is a good disc if

$$F_\varepsilon(v_\varepsilon, B(x_i, \varepsilon^{1/4}) \cap \Omega) \leq C_0 |\ln \varepsilon|$$

and $B(x_i, \varepsilon^{1/4})$ is an initial bad disc if

$$F_\varepsilon(v_\varepsilon, B(x_i, \varepsilon^{1/4}) \cap \Omega) > C_0 |\ln \varepsilon|. \quad (4.8)$$

Define $J = J(\varepsilon) := \{i \in I \mid B(x_i, \varepsilon^{1/4}) \text{ is an initial bad disc}\}$.

Lemma 13. *There is an integer N which depends only on g and Ω s.t.*

$$\text{Card } J \leq N.$$

Proof. Since each point of Ω is covered by at most $C > 0$ (universal constant) discs $B(x_i, \varepsilon^{1/4})$, we have

$$\sum_{i \in J} F_\varepsilon(v_\varepsilon, B(x_i, \varepsilon^{1/4}) \cap \Omega) \leq C F_\varepsilon(v_\varepsilon, \Omega).$$

The previous assertion implies that $\text{Card } J \leq \frac{C\pi d}{C_0} + 1$. \square

Let $\rho(\varepsilon) = \rho \downarrow 0$ be s.t.

$$\frac{\rho}{\lambda\delta^{3/2}} \rightarrow 0 \text{ and } \frac{|\ln \rho|^3}{|\ln \varepsilon|} \rightarrow 0. \quad (4.9)$$

Note that from Assumption (1.3), such a ρ exists, e.g., $\rho = (\lambda\delta)^2$.

The following result is a straightforward variant of Theorem IV.1 in [4].

Lemma 14. *Let $\varepsilon_n \downarrow 0$. Then (possibly after passing to a subsequence and relabeling the indices), we may choose $J' \subset J$ and a constant κ independent of n s.t.*

$$J' = \{1, \dots, N'\}, \quad N' = \text{Cst},$$

$$|x_i - x_j| \geq 16\kappa\rho \text{ for } i, j \in J', i \neq j$$

and

$$\cup_{i \in J} B(x_i, \varepsilon_n^{1/4}) \subset \cup_{i \in J'} B(x_i, \kappa\rho).$$

For $i \in J'$, we say that $B(x_i, 2\kappa\rho)$ is a bad disc.

Proposition 15. *We have*

1. $\frac{\rho}{\text{dist}(B(x_i, 2\kappa\rho), \partial\Omega)} \rightarrow 0$.
2. $\text{deg}_{\partial B(x_i, 2\kappa\rho)}(v_{\varepsilon_n}) > 0$.
3. $F_{\varepsilon_n}(v_{\varepsilon_n}, B(x_i, 2\kappa\rho)) \geq \pi b^2 \text{deg}_{\partial B(x_i, 2\kappa\rho)}(v_{\varepsilon_n}) \ln \frac{\rho}{\varepsilon_n} - \mathcal{O}(1)$.
4. $|v_{\varepsilon_n}| \geq 1 - C \sqrt{\frac{|\ln \rho|}{|\ln \varepsilon_n|}}$ in $\Omega \setminus \cup_{i \in J'} B(x_i, 2\kappa\rho)$.

Proof. We prove Assertions 1., 2. and 3.. Set

$$J'_0 := \{i \in J' \mid \text{deg}_{\partial(B(x_i, 2\kappa\rho) \cap \Omega)}(v_{\varepsilon_n}) > 0\}.$$

Since $|v_{\varepsilon_n}| \geq \frac{7}{8}$ in $\Omega \setminus \overline{\cup_{i \in J'} B(x_i, 2\kappa\rho)}$, we have

$$0 < d = \sum_{I \in J'} \text{deg}_{\partial(B(x_i, 2\kappa\rho) \cap \Omega)}(v_{\varepsilon_n}) \leq \sum_{I \in J'_0} \text{deg}_{\partial(B(x_i, 2\kappa\rho) \cap \Omega)}(v_{\varepsilon_n}). \quad (4.10)$$

Consequently $J'_0 \neq \emptyset$.

Up to a subsequence, we may assume that J'_0 is independent of n .

From Proposition 12, for all $i \in J'_0$, we have $\text{dist}(B(x_i, \varepsilon_n^{1/4}), \partial\Omega) \gtrsim \delta$ (or δ^P if the pinning term is not periodic). Consequently, for $i \in J'_0$ we find

$$\frac{\text{dist}(B(x_i, 2\kappa\rho), \partial\Omega)}{\rho} \rightarrow 0 \quad (4.11)$$

since $\frac{\rho}{\lambda \delta^{3/2}} \rightarrow 0$.

Assertions 1., 2. and 3. will follow from the estimate

$$F_{\varepsilon_n}(v_{\varepsilon_n}, B(x_i, 2\kappa\rho)) \geq b^2 \pi \text{deg}_{\partial B(x_i, 2\kappa\rho)}(v_{\varepsilon_n}) \ln \frac{\rho}{\varepsilon_n} - \mathcal{O}(1), \quad (4.12)$$

valid for $i \in J'_0$. Indeed, assume for the moment that (4.12) holds.

Then, by combining (4.2), (4.3), (4.8), (4.9), (4.10) and (4.12), we find that $J'_0 = J'$, i.e., 2. holds. Consequently, by combining Assertion 2. with (4.11), Assertion 1. yields and from Assertion 2. and (4.12), Assertion 3. holds.

We now turn to the proof of (4.12), which relies on Proposition 4.1 in [19]. We apply this proposition in the domain $B = B(0, 2\kappa)$, to the function $v'(x) = v_{\varepsilon_n}(\rho(x - x_i))$ and with the rescaled parameter $\xi_{\text{meso}} = \frac{\varepsilon}{\rho}$.

Note that, from (4.9), $\varepsilon \ll \xi_{\text{meso}} \ll \rho \ll \lambda\delta^{3/2}$ and $|\ln \varepsilon| \sim |\ln \xi_{\text{meso}}| \gg |\ln(\lambda\delta)|$.

Clearly, v' satisfies

$$\begin{aligned} \int_B \left\{ |\nabla v'|^2 + \frac{1}{\xi_{\text{meso}}^2} (1 - |v'|^2)^2 \right\} &= \int_{B(x_i, 2\kappa\rho)} \left\{ |\nabla v_{\varepsilon_n}|^2 + \frac{1}{\varepsilon^2} (1 - |v_{\varepsilon_n}|^2)^2 \right\} \\ &= \mathcal{O}(|\ln \varepsilon|) = \mathcal{O}(|\ln \xi_{\text{meso}}|). \end{aligned}$$

Hence, one may apply the following result of Serfaty and Sandier: there is $(B_j)_{j \in I}$, a finite covering of

$$\{x \in B(0, 2\kappa - \xi_{\text{meso}}/b) \mid |v'(x)| \leq 1 - (\xi_{\text{meso}}/b)^{1/8}\}$$

with disjoint balls B_j of radius $r_j < 10^{-3}$ s.t.

$$\frac{1}{2} \int_{B \cap \cup B_j} \left\{ |\nabla v'|^2 + \frac{b^2}{\xi_{\text{meso}}^2} (1 - |v'|^2)^2 \right\} \geq \pi \sum_j d_j |\ln \xi_{\text{meso}}| - \mathcal{O}(1);$$

$$\text{here } d_j = \begin{cases} |\deg_{\partial B_j}(v')| & \text{if } B_j \subset B(0, 2\kappa - \xi_{\text{meso}}/b) \\ 0 & \text{otherwise} \end{cases}.$$

Note that from construction, $\{|v_{\varepsilon_n}| \leq 7/8\} \subset \cup_j B(x_i, \varepsilon_n^{1/4}) \subset \cup_j B(x_i, \kappa\rho)$. Consequently:

$$\text{if } \deg_{\partial(B_j \cap B(0, 2\kappa - \xi_{\text{meso}}/b))}(v') \neq 0, \text{ then we have } B_j \subset B(0, \frac{3}{2}\kappa).$$

Therefore, $\sum d_j = \deg_{\partial B(0, 2\kappa)}(v') = \deg_{\partial B(x_i, 2\kappa\rho)}(v_{\varepsilon_n})$ and

$$\begin{aligned} \frac{1}{2} \int_{B(x_i, 2\kappa\rho)} \left\{ |\nabla v_{\varepsilon_n}|^2 + \frac{1}{2\varepsilon^2} (1 - |v_{\varepsilon_n}|^2)^2 \right\} &\geq \pi \deg_{\partial B(x_i, 2\kappa\rho)}(v_{\varepsilon_n}) |\ln \xi_{\text{meso}}| - \mathcal{O}(1) \\ &= \pi \deg_{\partial B(x_i, 2\kappa\rho)}(v_{\varepsilon_n}) \ln \frac{\rho}{\varepsilon} - \mathcal{O}(1). \end{aligned}$$

Thus (4.12) holds.

The last assertion is obtained using Lemmas 10 and 11. Indeed, note that the proof of (4.12) gives a more precise result

$$F_{\varepsilon_n}(v_{\varepsilon_n}, B(x_i, \frac{3}{2}\kappa\rho)) \geq b^2 \pi \deg_{\partial B(x_i, 2\kappa\rho)}(v_{\varepsilon_n}) \ln \frac{\rho}{\varepsilon_n} - \mathcal{O}(1).$$

Let $x \in \Omega \setminus \cup_j B(x_i, 2\kappa\rho)$ then $B(x, \varepsilon_n^{1/4}) \cap B(x_i, \frac{3}{2}\kappa\rho) = \emptyset$. Consequently, using Lemma 10 and the previous lower bound, we obtain:

$$F_{\varepsilon_n}(v_{\varepsilon_n}, B(x, \varepsilon_n^{1/4})) \leq I_{2\kappa\rho, \varepsilon_n} + C_0 \leq \pi d |\ln \rho| + C_0.$$

Therefore, from Lemma 11, there is $C > 0$, independent of x s.t. $|v_{\varepsilon_n}(x)| \geq 1 - C \sqrt{\frac{|\ln \rho|}{|\ln \varepsilon_n|}}$. \square

4.2.2 Location and degree of bad discs

Let $w_n = \frac{v_{\varepsilon_n}}{|v_{\varepsilon_n}|} \in H^1(\Omega \setminus \cup_{J'} \overline{B(x_i, 2\kappa\rho)}, \mathbb{S}^1)$.

Proposition 16. *The map w_n is an almost minimizing function for $I_{2\kappa\rho, \varepsilon_n}$.*

Proof. Indeed, denote $K_n = \frac{1}{2} \int_{\Omega \setminus \cup_{J'} B(x_i, 2\kappa\rho)} U_{\varepsilon_n}^2 |\nabla w_n|^2$, then we have

$$\begin{aligned}
K_n &\leq F_{\varepsilon_n}(v_{\varepsilon_n}, \Omega \setminus \cup_{J'} \overline{B(x_i, 2\kappa\rho)}) + \int_{\Omega \setminus \cup_{J'} \overline{B(x_i, 2\kappa\rho)}} (1 - |v_{\varepsilon_n}|^2) |\nabla w_n|^2 \\
&= F_{\varepsilon_n}(v_{\varepsilon_n}, \Omega) - F_{\varepsilon_n}(v_{\varepsilon_n}, \cup_{J'} B(x_i, 2\kappa\rho)) + \int_{\Omega \setminus \cup_{J'} \overline{B(x_i, 2\kappa\rho)}} (1 - |v_{\varepsilon_n}|^2) |\nabla w_n|^2 \\
&\leq (4.2), \text{ Prop 15} \leq I_{2\kappa\rho, \varepsilon_n} + C \sqrt{\frac{|\ln \rho|}{|\ln \varepsilon_n|}} \int_{\Omega \setminus \cup_{J'} \overline{B(x_i, 2\kappa\rho)}} |\nabla w_n|^2 + \mathcal{O}(1) \\
&\leq (4.2), \text{ Prop 15} \leq I_{2\kappa\rho, \varepsilon_n} + C \sqrt{\frac{|\ln \rho|}{|\ln \varepsilon_n|}} F_{\varepsilon_n}(v_{\varepsilon_n}, \Omega \setminus \cup_{J'} \overline{B(x_i, 2\kappa\rho)}) + \mathcal{O}(1) \\
&\leq (4.1), (4.3) \leq I_{2\kappa\rho, \varepsilon_n} + C \sqrt{\frac{|\ln \rho|^3}{|\ln \varepsilon_n|}} + \mathcal{O}(1) \\
&\leq (4.9) \leq I_{2\kappa\rho, \varepsilon_n} + \mathcal{O}(1).
\end{aligned}$$

□

By combining Proposition 5 with Proposition 16 in the periodic case or Proposition 9 if the pinning term is not periodic, we obtain the following

Corollary 17. *The configuration $\{(x_1, \dots, x_{N'}), (\deg_{\partial B(x_1, 2\kappa\rho)}(v_{\varepsilon_n}), \dots, \deg_{\partial B(x_{N'}, 2\kappa\rho)}(v_{\varepsilon_n}))\}$ is an almost minimizing configuration of $I_{2\kappa\rho, \varepsilon_n}$ and consequently, $N' = d$, $\deg_{\partial B(x_i, 2\kappa\rho)}(v_{\varepsilon_n}) = 1$ for all i and there is $\eta_0 > 0$ independent of large n s.t.*

$$\min \left\{ \min_{i \neq j} |x_i - x_j|, \min_i \text{dist}(x_i, \partial\Omega) \right\} > 2\eta_0,$$

$$B(x_i, 2\eta_0\lambda\delta) \subset \omega_\varepsilon.$$

4.3 H_{loc}^1 -weak convergence

In order to keep notations simple, we replace from now on, $2\kappa\rho$ by $\rho/2$.

Using Corollary 17, up to subsequence, there is $\{a_1, \dots, a_d\} \subset \Omega$ s.t. possibly after passing to a subsequence, we have $x_i^n = x_i \rightarrow a_i$.

Let $\rho_0 > 0$ be defined as

$$\rho_0 = 10^{-2} \cdot \min_{k \neq l} \{\text{dist}(a_k, \partial\Omega), |a_k - a_l|\}.$$

Proposition 18. *We have $\int_{\Omega} \left\{ |\nabla |v_{\varepsilon_n}||^2 + \frac{1}{\varepsilon_n^2} (1 - |v_{\varepsilon_n}|^2)^2 \right\} = \mathcal{O}(1)$.*

Proof. From (4.2), Proposition 15 (Assertion 1., 2. and 3.) and Proposition 16, we infer that

$$\int_{\Omega \setminus \cup_i B(x_i, \rho/2)} \left\{ |\nabla |v_{\varepsilon_n}|^2 + \frac{1}{\varepsilon_n^2} (1 - |v_{\varepsilon_n}|^2)^2 \right\} = \mathcal{O}(1).$$

Consequently it suffices to obtain a similar estimate in $B(x_i, \rho/2)$. Note that $B(x_i, \rho) \subset \omega_\varepsilon$. Thus, if we set

$$u'(x) = \frac{u_{\varepsilon_n}(x_i + \rho x)}{b} : B(0, 1) \rightarrow \mathbb{C},$$

then u' solves

$$-\Delta u' = \frac{1}{\left(\frac{\varepsilon_n}{b\rho}\right)^2} u'(1 - |u'|^2) \text{ in } B(0, 1).$$

From [5], we obtain

$$\frac{1}{2} \int_{B(0, 1/2)} \left\{ |\nabla |u'|^2 + \frac{b^2 \rho^2}{2\varepsilon_n^2} (1 - |u'|^2)^2 \right\} = \mathcal{O}(1).$$

This estimate is the subject of Theorem 1 for the potential part and Proposition 1 in [5] for the gradient of the modulus (see also Corollary 1 in [5]).

Set $K_n = \frac{1}{2} \int_{B(0, 1/2)} \left\{ |\nabla |u'|^2 + \frac{b^2 \rho^2}{2\varepsilon_n^2} (1 - |u'|^2)^2 \right\}$. Using Proposition 1, we obtain

$$\begin{aligned} K_n = \mathcal{O}(1) &= \frac{1}{2b^2} \int_{B(x_i, \rho/2)} \left\{ |\nabla |U_{\varepsilon_n} v_{\varepsilon_n}|^2 + \frac{b^4}{2\varepsilon_n^2} \left(1 - \frac{|U_{\varepsilon_n} v_{\varepsilon_n}|^2}{b^2}\right)^2 \right\} \\ &= \frac{1}{2} \int_{B(x_i, \rho/2)} \left\{ |\nabla |v_{\varepsilon_n}|^2 + \frac{b^2}{2\varepsilon_n^2} (1 - |v_{\varepsilon_n}|^2)^2 \right\} + o_n(1). \end{aligned}$$

Consequently, Proposition 18 holds. \square

Proposition 19. *There is $C > 0$ s.t. for (fixed) $0 < \eta \leq \rho_0$ and n sufficiently large we have*

$$\frac{1}{2} \int_{\Omega' \setminus \cup B(a_i, \eta)} U_{\varepsilon_n}^2 |\nabla v_{\varepsilon_n}|^2 - I_{\eta, \varepsilon_n} \leq C. \quad (4.13)$$

Proof. We prove the result for the periodic pinning term. The proof for a non-periodic pinning term is similar.

We use results proved in Appendix D, Section D.2: Proposition 33 and Lemma 34.

Set

$$\mu_\varepsilon(B(x_0, R) \setminus \overline{B(x_0, r)}, \tilde{d}) = \inf_{\substack{w \in H^1(B(x_0, R) \setminus B(x_0, r), \mathbb{S}^1) \\ \deg_{\partial B(x_0, R)}(w) = \tilde{d}}} \frac{1}{2} \int_{B(x_0, R) \setminus \overline{B(x_0, r)}} U_\varepsilon^2 |\nabla w|^2.$$

Since the configuration (x_1^n, \dots, x_d^n) is almost minimizing, from Proposition 33, we obtain that

$$\left| I_{\eta, \varepsilon_n} - \sum_i \mu_{\varepsilon_n} \left(B(x_i^n, \rho_0) \setminus \overline{B(x_i^n, \eta)} \right) \right| \leq C; \quad (4.14)$$

here C is independent of η and large n . Using Lemma 34 we have:

- by Assertion 1. we find that

$$\frac{1}{2} \int_{\cup B(x_n^i, 5\eta) \setminus \overline{B(x_n^i, \eta/2)}} U_{\varepsilon_n}^2 |\nabla w_n|^2 \leq C, \quad (4.15)$$

- by Assertion 2. we find that

$$\frac{1}{2} \int_{\cup B(x_n^i, \rho_0) \setminus \overline{B(x_n^i, \eta)}} U_{\varepsilon_n}^2 |\nabla w_n|^2 - \sum_i \mu_{\varepsilon_n} \left(B(x_n^i, \rho_0) \setminus \overline{B(x_n^i, \eta)} \right) \leq C, \quad (4.16)$$

- by Assertion 3. we obtain

$$\frac{1}{2} \int_{\Omega \setminus \cup B(x_n^i, \rho_0)} U_{\varepsilon_n}^2 |\nabla w_n|^2 \leq C; \quad (4.17)$$

here C is independent of η and large n .

Denote $K_{\eta, n} = \frac{1}{2} \int_{\Omega \setminus \cup B(a_i, \eta)} U_{\varepsilon_n}^2 |\nabla v_{\varepsilon_n}|^2 - I_{\eta, \varepsilon_n}$. We have for a fixed $\eta > 0$ and large n (s.t. $B(x_n^i, \eta/2) \subset B(a_i, 3\eta/4)$)

$$\begin{aligned} K_{\eta, n} &\leq (4.14), \text{ Prop. 18} \leq \frac{1}{2} \int_{\Omega \setminus \cup B(a_i, \eta)} U_{\varepsilon_n}^2 |\nabla w_n|^2 - \sum_i \mu_{\varepsilon_n} \left(B(x_n^i, \rho_0) \setminus \overline{B(x_n^i, \eta)} \right) + C' \\ &\leq (4.15), (4.17) \leq \frac{1}{2} \int_{\cup B(x_n^i, \rho_0) \setminus \overline{B(x_n^i, \eta)}} U_{\varepsilon_n}^2 |\nabla w_n|^2 - \sum_i \mu_{\varepsilon_n} \left(B(x_n^i, \rho_0) \setminus \overline{B(x_n^i, \eta)} \right) + C'' \\ &\leq (4.16) \leq C. \end{aligned}$$

Here C', C'' and C are constants independent of η, n . \square

Consequently, there is $v_* \in H_{\text{loc}}^1(\overline{\Omega} \setminus \{a_1, \dots, a_d\}, \mathbb{S}^1)$ s.t. $v_{\varepsilon_n} \rightharpoonup v_*$ in $H_{\text{loc}}^1(\overline{\Omega} \setminus \{a_1, \dots, a_d\})$.

In order to obtain the expression of the homogenized problem, we use the *unfolding operator* (see [8], definition 2.1). More specifically, we define, for $\Omega_0 \subset \mathbb{R}^2$ an open set, $p \in (1, \infty)$ and $\delta > 0$,

$$\begin{aligned} \mathcal{T}_\delta : L^p(\Omega_0) &\rightarrow L^p(\Omega_0 \times Y) \\ \phi &\mapsto \mathcal{T}_\delta(\phi)(x, y) = \begin{cases} \phi \left(\delta \left[\frac{x}{\delta} \right] + \delta y \right) & \text{for } (x, y) \in \Omega_\delta^{\text{incl}} \times Y \\ 0 & \text{for } (x, y) \in \Lambda_\delta \times Y \end{cases} \end{aligned}$$

Here, $Y = (-1/2, 1/2)^2$, $[s]$ is the integer part of $s \in \mathbb{R}$ and

$$\Omega_\delta^{\text{incl}} := \bigcup_{\substack{Y_\delta^K \subset \Omega_0, K \in \mathbb{Z}^2 \\ Y_\delta^K = \delta \cdot (K + Y)}} \overline{Y_\delta^K}, \quad \Lambda_\delta := \Omega_0 \setminus \Omega_\delta^{\text{incl}} \quad \text{and} \quad \left[\frac{x}{\delta} \right] := \left(\left[\frac{x_1}{\delta} \right], \left[\frac{x_2}{\delta} \right] \right).$$

A straightforward adaptation of a result of Myrto Sauvageot ([20], Theorem 4) gives the following

Proposition 20. *Let $\Omega_0 \subset \mathbb{R}^2$ be a smooth bounded open set. Let $v_n \in H^2(\Omega_0, \mathbb{C})$ be s.t.*

1. $|v_n| \leq 1$ and $\int_{\Omega_0} (1 - |v_n|^2)^2 \rightarrow 0$,

2. $v_n \rightharpoonup v_*$ in $H^1(\Omega_0)$ for some $v_* \in H^1(\Omega_0, \mathbb{S}^1)$,
3. there are $H_n \in W^{1,\infty}(\Omega_0, [b^2, 1])$ and $\delta = \delta_n \downarrow 0$ s.t. $\mathcal{T}_\delta(H_n)(x, y) \rightarrow H_0(y)$ in $L^2(\Omega_0 \times Y)$,
4. $-\operatorname{div}(H_n \nabla v_n) = v_n f_n(x)$, $f_n \in L^\infty(\Omega_0, \mathbb{R})$.

Then v_* is the solution of

$$-\operatorname{div}(\mathcal{A} \nabla v_*) = (\mathcal{A} \nabla v_* \cdot \nabla v_*) v_*$$

where \mathcal{A} is the homogenized matrix of $H_0(\frac{\cdot}{\delta}) \operatorname{Id}_{\mathbb{R}^2}$.

The proof of Proposition 20 is postponed to [Appendix F](#).

We apply the above proposition to $\Omega_0 = \Omega \setminus \cup \overline{B}(a_i, \eta)$, $\delta = \delta_n \downarrow 0$ the sequence which defines a_{ε_n} and $H_n = U_{\varepsilon_n}^2$. By a straightforward application of Proposition 1, we obtain

$$\mathcal{T}_\delta(U_{\varepsilon_n}^2)(x, y) \xrightarrow{L^2(\Omega_0 \times Y)} \begin{cases} a^2(y) = 1 - (1 - b^2) \mathbb{1}_\omega(y) & \text{if } \lambda \equiv 1 \\ 1 & \text{if } \lambda \rightarrow 0 \end{cases}.$$

We find that v_* solves

$$\begin{aligned} -\operatorname{div}(\mathcal{A} \nabla v_*) &= (\mathcal{A} \nabla v_* \cdot \nabla v_*) v_*, & \text{if } \lambda \equiv 1, \\ -\Delta v_* &= |\nabla v_*|^2 v_*, & \text{if } \lambda \rightarrow 0. \end{aligned}$$

Here \mathcal{A} is the homogenized matrix of $a^2(\frac{\cdot}{\delta}) \operatorname{Id}_{\mathbb{R}^2}$.

4.4 The small bad discs

4.4.1 Definition

From the global bound on the potential part (Proposition 18), one may construct bad discs of radius ε , in the following sense:

as in [4] (Theorem III.3), for $l \geq 2$, there are $\kappa_l, \mu_l > 0$ (depending only on Ω, g and l) s.t. for $x \in \Omega$, if

$$\frac{1}{\varepsilon^2} \int_{B(x, 2\kappa_l \varepsilon)} (1 - |v_\varepsilon|^2)^2 \leq \mu_l$$

then

$$|v_\varepsilon| \geq 1 - \frac{1}{l^2} \text{ in } B(x, \kappa_l \varepsilon).$$

We fix $l \geq 2$ and we drop the subscript l . Let $(B(x_i, \kappa \varepsilon))_{i \in I}$ be a family of discs s.t

$$x_i \in \Omega, \forall i \in I,$$

$$B(x_i, \kappa \varepsilon / 2) \cap B(x_j, \kappa \varepsilon / 2) = \emptyset \text{ if } i \neq j,$$

$$\cup_{i \in I} B(x_i, \kappa \varepsilon) \supset \Omega.$$

We say that $B(x_i, \kappa \varepsilon)$ is a small good disc if

$$\frac{1}{\varepsilon^2} \int_{B(x_i, 2\kappa \varepsilon)} (1 - |v|^2)^2 < \mu.$$

If $B(x_i, \kappa\varepsilon)$ is not a small good disc, then we call it a small bad disc. We denote $J \subset I$ the set of indices of small bad discs.

Following [4], using Proposition 18, there is $N_l = N > 0$ (depending only on Ω , g and l) s.t. $\text{Card}(J) \leq N$.

Using Lemma 27, for $\varepsilon_n \downarrow 0$, possibly after passing to a subsequence and relabeling the discs, there are $J' \subset J$ and $\kappa' \in \{\kappa, \dots, 9^{N-1}\kappa\}$ s.t.

$$\{|v_{\varepsilon_n}| < 1 - 1/l^2\} \subset \cup_{i \in J} B(x_i, \kappa\varepsilon_n) \subset \cup_{i \in J'} B(x_i, \kappa'\varepsilon_n)$$

and

$$\frac{|x_i - x_j|}{\varepsilon_n} \geq 8\kappa' \text{ if } i, j \in J', i \neq j.$$

4.4.2 Separation of small bad discs

By a standard iterative procedure, we may assume that the small bad discs are mutually far away in the ε -scale.

Proposition 21. *Possibly after passing to a subsequence, we have, for large R and $J'' \subset J'$,*

$$\{|v_{\varepsilon_n}| < 1 - 1/l^2\} \subset \cup_{i \in J''} B(x_i^n, R\varepsilon_n),$$

where, for $i \neq j$,

$$\frac{|x_i^n - x_j^n|}{\varepsilon_n} \rightarrow \infty \text{ as } n \rightarrow \infty.$$

4.4.3 Each bad disc contains exactly one small bad disc

We already know that the separated small bad discs are covered by the ρ -bad discs defined in Lemma 14. We next prove that there are exactly d small bad discs and consequently, there is exactly one small bad discs per ρ -bad discs.

Proposition 22. *For large n and for all $i \in J''$, we have*

$$\deg_{\partial B(x_i^n, R\varepsilon_n)}(v_{\varepsilon_n}) = 1.$$

Proof. First we prove that, for large n and for all i , we have

$$\deg_{\partial B(x_i^n, R\varepsilon_n)}(v_{\varepsilon_n}) \neq 0.$$

We argue by contradiction and we assume that, up to a subsequence, there is i s.t. $\deg_{\partial B(x_i^n, R\varepsilon_n)}(v_{\varepsilon_n}) = 0$.

Set $M_n = \min \left(b \min_{i \neq j} \frac{|x_i^n - x_j^n|}{8R\varepsilon_n}, \delta^{-1} \right)$ and set

$$\begin{aligned} u'_n : B(0, M_n) &\rightarrow \mathbb{C} \\ x &\mapsto \frac{u_{\varepsilon_n} \left(\frac{\varepsilon_n}{b} x + x_i^n \right)}{b}. \end{aligned}$$

Note that, $B(x_i^n, M\varepsilon_n) \subset \omega_\varepsilon$ and by Proposition 21, we have $M_n \rightarrow \infty$.

It is easy to check that u'_n solves $-\Delta u'_n = u'_n(1 - |u'_n|^2)$. Following [7], up to a subsequence,

$$u'_n \rightarrow u_0 \text{ in } C_{\text{loc}}^2(\mathbb{R}^2); \tag{4.18}$$

here $u_0 : \mathbb{R}^2 \rightarrow \mathbb{C}$ solves $-\Delta u_0 = u_0(1 - |u_0|^2)$ in \mathbb{R}^2 .

Then two cases occur: $\int_{\mathbb{C}} (1 - |u_0|^2)^2 < \infty$ or $\int_{\mathbb{C}} (1 - |u_0|^2)^2 = \infty$.

Assume first that $\int_{\mathbb{C}} (1 - |u_0|^2)^2 < \infty$. From [7], noting that the degree of u_0 on large circles centered in 0 is 0, we obtain that $u_0 = \text{Cst} \in \mathbb{S}^1$ and consequently $\int_{\mathbb{C}} (1 - |u_0|^2)^2 = 0$.

Since $u'_n \rightarrow u_0$ in $L^4(B(0, 2bR))$, we find that

$$\begin{aligned} \int_{B(0, 2bR)} (1 - |u'_n|^2)^2 &= \frac{b^2}{\varepsilon_n^2} \int_{B(x_i^n, 2R\varepsilon_n)} (1 - |u_n/b|^2)^2 \\ &= \frac{b^2}{\varepsilon_n^2} \int_{B(x_i^n, 2R\varepsilon_n)} (1 - |v_{\varepsilon_n}|^2)^2 + o_n(1) \rightarrow 0. \end{aligned}$$

Noting that $B(x_i^n, \kappa\varepsilon_n)$ is a small bad disc and that $B(x_i^n, 2\kappa\varepsilon_n) \subset B(x_i^n, 2R\varepsilon_n)$, we have a contradiction.

Therefore $\int_{\mathbb{C}} (1 - |u_0|^2)^2 = \infty$. Consequently, there is $M > 0$ s.t.

$$\int_{B(0, bM)} (1 - |u_0|^2)^2 \geq \sup_n \left\{ \frac{4b^2}{\varepsilon_n^2} \int_{\Omega} (1 - |v_{\varepsilon_n}|^2)^2 \right\}.$$

Thus, for large n we have

$$\begin{aligned} \int_{B(0, bM)} (1 - |u'_n|^2)^2 &= \frac{b^2}{\varepsilon_n^2} \int_{B(x_i^n, M\varepsilon_n)} (1 - |u_{\varepsilon_n}/b|^2)^2 \\ &= \frac{b^2}{\varepsilon_n^2} \int_{B(x_i^n, M\varepsilon_n)} (1 - |v_{\varepsilon_n}|^2)^2 + o_n(1) \\ &\geq \sup_n \left\{ \frac{2b^2}{\varepsilon_n^2} \int_{\Omega} (1 - |v_{\varepsilon_n}|^2)^2 \right\}, \end{aligned}$$

which is a contradiction with $B(x_i^n, M\varepsilon_n) \subset \Omega$.

Consequently we obtain that for large n , $\deg_{\partial B(x_i^n, R\varepsilon_n)}(v_{\varepsilon_n}) \neq 0$.

Now we prove that

$$\deg_{\partial B(x_i^n, R\varepsilon_n)}(v_{\varepsilon_n}) = 1 \text{ for all } i \text{ and large } n. \quad (4.19)$$

Note that each small bad disc contains at least a zero of v_{ε_n} . Consequently, for ρ satisfying (4.9), all small bad discs are included in a ρ -bad disc $B(y, \rho)$ defined in Lemma 14. (For sake of simplicity we wrote $B(y, \rho)$ instead of $B(y, 2\kappa\rho)$).

If $B(y, \rho)$ is a ρ -bad disc, we denote $\Lambda_y = \{i \in J'' \mid x_i^n \in B(y, \rho)\}$. Clearly, if $\text{Card}(\Lambda_y) = 1$, then (4.19) holds.

We define

$$\mathfrak{a}_n^y := \begin{cases} 10^{-2} \min_{i, j \in \Lambda_y, i \neq j} |x_i^n - x_j^n| & \text{if } \text{Card}(\Lambda_y) > 1 \\ R\varepsilon_n & \text{otherwise} \end{cases}.$$

From Proposition 21, if $\text{Card}(\Lambda_y) > 1$ then $\mathfrak{a}_n/\varepsilon_n \rightarrow \infty$.

For simplicity, we assume that $y = 0$ and let

$$\tilde{B} = B(0, 8) \setminus \bigcup_{i \in \Lambda_0} \overline{B\left(\frac{x_i}{\rho}, \frac{\mathfrak{a}_n^0}{\rho}\right)}.$$

Clearly, we are in position to apply Theorem 2 in [13] in the perforated domain \tilde{B} . After scaling, we find that

$$\frac{1}{2} \int_{B(y, 8\rho) \setminus \overline{B(x_i^n, \mathfrak{a}_n^y)}} |\nabla v_{\varepsilon_n}|^2 \geq \pi \left| \sum_{i \in \Lambda_y} \deg_{\partial B(x_i^n, R\varepsilon_n)}(v_{\varepsilon_n}) \right| \ln \frac{\rho}{\mathfrak{a}_n^y} - C = \pi \ln \frac{\rho}{\mathfrak{a}_n^y} - C.$$

In order to prove (4.19), we observe the case where there is y s.t. $\text{Card}(\Lambda_y) > 1$. Note that if for all y centers of ρ -bad discs we have $\text{Card}(\Lambda_y) = 1$, then (4.19) holds. Moreover if $\text{Card}(\Lambda_y) > 1$, then we have

$$\sum_{i \in \Lambda_y} |\deg_{\partial B(x_i^n, R\varepsilon_n)}(v_{\varepsilon_n})| > 1.$$

We obtain easily the following lower bound for $i \in \Lambda_y$:

$$\frac{1}{2} \int_{B(x_i^n, \mathfrak{a}_n^y) \setminus \overline{B(x_i^n, R\varepsilon_n)}} |\nabla v_{\varepsilon_n}|^2 \geq \pi \left| \deg_{\partial B(x_i^n, R\varepsilon_n)}(v_{\varepsilon_n}) \right| \ln \frac{\mathfrak{a}_n^y}{R\varepsilon_n} - C.$$

Summing for $i \in \Lambda_y$, we obtain that

$$\sum_{i \in \Lambda_y} \frac{1}{2} \int_{B(x_i^n, \mathfrak{a}_n^y) \setminus \overline{B(x_i^n, R\varepsilon_n)}} |\nabla v_{\varepsilon_n}|^2 \geq 2\pi \ln \frac{\mathfrak{a}_n^y}{R\varepsilon_n} - C.$$

Consequently, we deduce that

$$\sum_y \frac{1}{2} \int_{B(y, 8\rho) \setminus \overline{B(x_i^n, R\varepsilon_n)}} |\nabla v_{\varepsilon_n}|^2 \geq \pi d \ln \frac{\rho}{R\varepsilon_n} + \pi \sum_{y \text{ s.t. } \text{Card}(\Lambda_y) > 1} \ln \frac{\mathfrak{a}_n^y}{R\varepsilon_n} - \mathcal{O}_n(1).$$

From Lemma 10 and Propositions 16 and 15, we deduce easily

$$\frac{1}{2} \int_{\bigcup B(y, 8\rho) \setminus \overline{B(x_i^n, R\varepsilon_n)}} U_{\varepsilon_n}^2 |\nabla v_{\varepsilon_n}|^2 = \pi db^2 \ln \frac{\rho}{\varepsilon_n} + \mathcal{O}_n(1).$$

Combining the previous estimates, we obtain that

$$\{y \text{ center of } \rho\text{-bad discs} \mid \text{Card}(\Lambda_y) > 1\} = \emptyset,$$

and thus $\deg_{\partial B(x_i^n, R\varepsilon_n)}(v_{\varepsilon_n}) = 1$ for large n . \square

Corollary 23. *For large n , there is a unique zero inside each separated small bad discs defined in Proposition 21.*

Proof. From Proposition 22, one may assume that $v_{\varepsilon_n}(x_i^n) = 0$.

Let $i \in \{1, \dots, d\}$. In view of (4.18), if we denote

$$\begin{aligned} u'_n : B(0, M_n) &\rightarrow \mathbb{C} \\ x &\mapsto \frac{u_{\varepsilon_n}(\frac{\varepsilon_n}{b}x + x_i^n)}{b}, \end{aligned} \quad (4.20)$$

then, up to a subsequence, $u'_n \rightarrow u_0$ in $C^1(\overline{B(0, bR)})$.

Using the main result of [18], we have the existence of a universal function $f : \mathbb{R}^+ \rightarrow [0, 1]$ s.t.

$$u_0(x) = f(|x|)e^{i(\theta + \theta_i)} \text{ where } x = |x|e^{i\theta}, \theta_i \in \mathbb{R} \text{ and } f : \mathbb{R}^+ \rightarrow \mathbb{R}^+ \text{ is increasing.} \quad (4.21)$$

Therefore, we may apply Theorem 2.3 in [2] in order to obtain that, for large n , u'_n has a unique zero in $B(0, bR)$. Consequently, for large n , v_{ε_n} has a unique zero in $B(x_i^n, R\varepsilon_n)$. \square

Corollary 24. *One may consider that R depends only on l (it is independent of the extraction we consider), i.e, for $l \geq 2$ there is $R_l > 0$ s.t. for small ε , denoting $\{x_i^\varepsilon \mid i \in \{1, \dots, d\}\}$ the set of zeros of a minimizer v_ε , we have*

$$\{|v_\varepsilon| < 1 - 1/l^2\} \subset \cup_i B(x_i^\varepsilon, R_l \varepsilon).$$

Proof. From Corollary 23, one may assume that $v_{\varepsilon_n}(x_i^n) = 0$.

Let $f : \mathbb{R}^+ \rightarrow \mathbb{R}^+$ be defined as in (4.21) and u'_n as in (4.20). For $l \geq 2$, consider $R_l > 0$ be s.t.

$$l \mapsto R_l \text{ is increasing and } f(bR_l) \geq 1 - \frac{1}{2l^2}.$$

Note that from [21], one may consider $R_l \simeq \sqrt{2}l/b$.

By uniqueness of f , the full sequence $|u'_n|$ converges to f in $L^\infty [B(0, b \max \{R, R_l\})]$. Consequently, for n sufficiently large, since f is not decreasing,

$$\{|v_{\varepsilon_n}| < 1 - 1/l^2\} \subset \cup_i B(x_i^n, R_l \varepsilon_n).$$

□

4.5 Asymptotic expansion of $F_\varepsilon(v_\varepsilon)$

4.5.1 Statement of the main result and corollaries

Our main result is

Proposition 25. *For all $\varepsilon_n \downarrow 0$, up to a subsequence, there is $\rho = \rho(\varepsilon_n)$ s.t. $\varepsilon_n \ll \rho \ll \lambda\delta$ and s.t. when $n \rightarrow \infty$ the following holds*

$$F_{\varepsilon_n}(v_{\varepsilon_n}) \geq J_{\rho, \varepsilon_n} + db^2(\pi \ln \frac{b\rho}{\varepsilon_n} + \gamma) + o_n(1), \quad (4.22)$$

where $J_{\rho, \varepsilon}$ is defined in (3.6) and γ is a universal constant defined in [4], Lemma IX.1.

Corollary 26. *Let $\varepsilon_n \downarrow 0, \rho$ be as in Proposition 25. Then we have*

$$J_{\varepsilon_n, \varepsilon_n} - J_{\rho, \varepsilon_n} = \pi db^2 \ln \frac{\rho}{\varepsilon_n} + o_n(1).$$

Proof of Corollary 26. Using Proposition 3, consider $(x_1, \dots, x_d) \in \Omega^d$ a minimizing configuration of points for J_{ρ, ε_n} , i.e. s.t.

$$\hat{\mathcal{J}}_{\rho, \varepsilon_n}(x_1, \dots, x_d) = J_{\rho, \varepsilon_n}.$$

Combining Corollary 7 with Proposition 5, we have the existence of $c > 0$ s.t. $B(x_i, c\lambda\delta) \subset \omega_\varepsilon$.

Therefore, given a minimizing map w_n of $\hat{\mathcal{J}}_{\rho, \varepsilon_n}(x_1, \dots, x_d)$, we may easily construct a map $\tilde{w}_n \in H^1(\Omega \setminus \cup_i \overline{B(x_i, \varepsilon_n)}, \mathbb{S}^1)$ s.t. $\tilde{w}_n \in \mathcal{J}_{\varepsilon_n}(x_1, \dots, x_d)$ and

$$\begin{aligned} J_{\varepsilon_n, \varepsilon_n} &\leq \frac{1}{2} \int_{\Omega \setminus \cup B(x_i, \varepsilon_n)} U_{\varepsilon_n}^2 |\nabla \tilde{w}_n|^2 \\ &= \frac{1}{2} \int_{\Omega \setminus \cup B(x_i, \rho)} U_{\varepsilon_n}^2 |\nabla w_n|^2 + \frac{1}{2} \int_{\cup B(x_i, \rho) \setminus \cup B(x_i, \varepsilon_n)} U_{\varepsilon_n}^2 |\nabla \tilde{w}_n|^2 \\ &= J_{\rho, \varepsilon_n} + db^2 \pi \ln \frac{\rho}{\varepsilon_n} + o_n(1). \end{aligned} \quad (4.23)$$

On the other hand, Lemma 10 combined with Proposition 25 yield

$$J_{\rho, \varepsilon_n} + db^2(\pi \ln \frac{b\rho}{\varepsilon_n} + \gamma) + o_n(1) \leq F_{\varepsilon_n}(v_{\varepsilon_n}) \leq J_{\varepsilon_n, \varepsilon_n} + db^2(\pi \ln b + \gamma). \quad (4.24)$$

We conclude with the help of (4.23) and (4.24). \square

4.5.2 Proof of Theorem 5

We are now in position to prove Theorem 5, *i.e.*, we are going to prove that

$$F_{\varepsilon}(v_{\varepsilon}) = J_{\varepsilon, \varepsilon} + db^2(\pi \ln b + \gamma) + o_{\varepsilon}(1).$$

Indeed, using Lemma 10, it suffices to prove that

$$F_{\varepsilon}(v_{\varepsilon}) \geq J_{\varepsilon, \varepsilon} + db^2(\pi \ln b + \gamma) + o_{\varepsilon}(1).$$

This estimate is equivalent to:

$$\text{for all } \varepsilon_n \downarrow 0, \text{ up to subsequence, we have } F_{\varepsilon_n}(v_{\varepsilon_n}) \geq J_{\varepsilon_n, \varepsilon_n} + db^2(\pi \ln b + \gamma) + o_n(1).$$

Let $\varepsilon_n \downarrow 0$. Then, up to a subsequence, there is $\rho = \rho_n$ given by Proposition 25 s.t.

$$F_{\varepsilon_n}(v_{\varepsilon_n}) \geq J_{\rho, \varepsilon_n} + db^2(\pi \ln \frac{b\rho}{\varepsilon_n} + \gamma) + o_n(1).$$

We deduce from Corollary 26 that

$$\begin{aligned} F_{\varepsilon_n}(v_{\varepsilon_n}) &\geq J_{\varepsilon_n, \varepsilon_n} - db^2 \ln \frac{\rho}{\varepsilon_n} + db^2(\pi \ln \frac{b\rho}{\varepsilon_n} + \gamma) + o_n(1) \\ &= J_{\varepsilon_n, \varepsilon_n} + db^2(\pi \ln b + \gamma) + o_n(1), \end{aligned}$$

which ends the proof of Theorem 5.

4.5.3 Proof of Proposition 25

In order to construct ρ , we first define a suitable extraction.

For $l \in \mathbb{N} \setminus \{0, 1\}$, consider R_l given by Corollary 24.

Using Proposition 22 and Corollary 23, for sufficiently large n , v_{ε_n} has exactly d zeros $x_1^n = x_1, \dots, x_d^n = x_d$.

Clearly, these zeros are well separated and far from $\partial\Omega$ (independently of n).

Fix $i \in \{1, \dots, d\}$ and consider

$$\begin{aligned} u'_n : B(0, \delta^2/\varepsilon_n) &\rightarrow \mathbb{C} \\ x &\mapsto \frac{u_{\varepsilon_n}(\frac{\varepsilon_n}{b}x + x_i)}{b}. \end{aligned}$$

For simplicity, assume $x_i = 0$.

Up to a subsequence, one has, as in (4.21),

$$u'_n \rightarrow u_0 \text{ in } C_{\text{loc}}^2(\mathbb{R}^2, \mathbb{C}), \quad u_0(x) = f(|x|)e^{i(\theta + \theta_i)}$$

where $x = |x|e^{i\theta}$, $\theta_i \in \mathbb{R}$ and $f : \mathbb{R}^+ \rightarrow \mathbb{R}^+$ is increasing.

Consequently, for $l \in \mathbb{N} \setminus \{0, 1\}$, one may construct an extraction $(n_l)_l$ s.t., denoting $u'_{n_l} = u'_l = |u'_l|e^{i(\theta+\phi'_l)}$ and $v_{\varepsilon_{n_l}} = v_l$,

$$\{|v_l| < 1 - 1/l^2\} \subset \cup_i B(x_i, R_l \varepsilon_{n_l}), \quad (4.25)$$

$$\rho_l := R_l \varepsilon_{n_l} \leq \frac{\lambda^2 \delta^2}{l},$$

$$\left| \int_{B(0, bR_l)} |\nabla u'_l|^2 + \frac{1}{2} (1 - |u'_l|^2)^2 - \int_{B(0, bR_l)} |\nabla u_0|^2 + \frac{1}{2} (1 - |u_0|^2)^2 \right| \leq \frac{1}{l}, \quad (4.26)$$

and

$$\|\phi'_l - \theta_i\|_{C^1(B(0, bR_l))} \leq \frac{1}{l}. \quad (4.27)$$

Here $R_l \simeq \sqrt{2}l/b$ and is defined in Corollary 24.

Following the proof of Proposition 1, Step 2 in [7], one has

$$\int_{B(0, \frac{\lambda^2 \delta^2}{\varepsilon_{n_l}}) \setminus \overline{B(0, R_l)}} |\nabla \phi'_l|^2 \leq C \text{ independently of } l. \quad (4.28)$$

In $B(0, \lambda^2 \delta^2) \setminus \overline{B(0, \varepsilon_{n_l})}$, we denote $v_{n_l} = v_l = |v_l|e^{i(\theta+\phi_l)}$ ($e^{i\theta} = x/|x|$). By conformal invariance, (4.27) implies that

$$\|\phi_l - \theta_i\|_{L^\infty(\partial B(0, \rho_l))} + |\phi_l|_{H^{1/2}(\partial B(0, \rho_l))} \leq \frac{C}{l}. \quad (4.29)$$

Denote $W_l = B(0, 2\rho_l) \setminus \overline{B(0, \rho_l)}$ and consider $\psi_i^l \in H^{1/2}(\partial W_l, \mathbb{R})$ s.t.

$$\psi_l = \psi_i^l = \begin{cases} \phi_l - \theta_i & \text{on } \partial B(0, \rho_l) \\ 0 & \text{on } \partial B(0, 2\rho_l) \end{cases}.$$

Using (4.29), it is clear that $\|\psi_l\|_{H^{1/2}} = \mathcal{O}(1/l)$. From this, it is straightforward that there exists a constant $C_0 > 0$ (independent of l) and $\Psi_i^l \in H^1(W_l, \mathbb{R})$ s.t.

$$\text{tr}_{\partial W_l} \Psi_i^l = \psi_l = \psi_i^l \text{ and } \frac{1}{2} \int_{W_l} |\nabla \Psi_i^l|^2 \leq \frac{C_0}{l^2}.$$

Finally we define $\Psi_l \in H^1(\Omega \setminus \cup \overline{B(x_i, \rho_l)}, \mathbb{R})$ by

$$\Psi_l = \begin{cases} \Psi_i^l(\cdot - x_i) & \text{in } x_i + W_l \\ 0 & \text{otherwise} \end{cases}$$

and

$$\tilde{w}_l = \frac{v_l}{|v_l|} e^{-i\Psi_l} \in \mathcal{J}_{\rho_l}(x_1, \dots, x_d).$$

Therefore, denoting $w_l = \frac{v_l}{|v_l|} = e^{i(\theta+\phi_l)}$, $U_l = U_{\varepsilon_{n_l}}$ and $\Omega_{\rho_l} = \Omega \setminus \overline{B(x_i, \rho_l)}$, we have

$$\hat{\mathcal{J}}_{\rho_l}(x_1, \dots, x_d) \leq \frac{1}{2} \int_{\Omega_{\rho_l}} U_l^2 |\nabla \tilde{w}|^2 = \frac{1}{2} \int_{\Omega_{\rho_l}} U_l^2 |\nabla w_l|^2 + 2U_l^2 \nabla(\theta + \phi_l) \cdot \nabla \Psi_l + o_l(1).$$

From (4.28), we obtain easily that

$$\left| \int_{\Omega_{\rho_l}} \nabla(\theta + \phi_l) \cdot \nabla \Psi_l \right| = \sum_i \left| \int_{x_i + W_l} \nabla(\theta + \phi_l) \cdot \nabla \Psi_i^l(\cdot - x_i) \right| = o_n(1)$$

and consequently

$$\hat{\mathcal{J}}_{\rho_l}(x_1, \dots, x_d) \leq \frac{1}{2} \int_{\Omega_{\rho_l}} U_l^2 |\nabla w_l|^2 + o_l(1). \quad (4.30)$$

On the other hand, from direct computations, one has

$$\frac{1}{2} \int_{\Omega_{\rho_l}} U_l^2 |\nabla v_l|^2 \geq \frac{1}{2} \int_{\Omega_{\rho_l}} U_l^2 |\nabla w_l|^2 + \frac{1}{2} \int_{\Omega_{\rho_l}} U_l^2 (|v_l|^2 - 1) |\nabla(\theta + \phi_l)|^2.$$

Using the same argument as Mironescu in [18], one may obtain that

$$\frac{1}{2} \int_{\Omega_{\rho_l}} U_l^2 (1 - |v_l|^2)^{1/2} |\nabla \theta|^2 \leq C \text{ with } C \text{ independent of } l. \quad (4.31)$$

From (4.31) and (4.25), we obtain

$$\frac{1}{2} \int_{\Omega_{\rho_l}} U_l^2 |\nabla v_l|^2 \geq \frac{1}{2} \int_{\Omega_{\rho_l}} U_l^2 |\nabla w_l|^2 - o_l(1).$$

Therefore, with (4.30),

$$F_{\varepsilon_{n_l}}(v_l, \Omega_{\rho_l}) + o_l(1) \geq \frac{1}{2} \int_{\Omega_{\rho_l}} U_l^2 |\nabla v_l|^2 + o_l(1) \geq \hat{\mathcal{J}}_{\rho_l}. \quad (4.32)$$

In order to complete the proof of (4.22), it suffices to estimate the contribution of the discs $B(x_i, \rho_l)$.

One has (using (4.26))

$$\begin{aligned} F_{\varepsilon_{n_l}}(v_l, B(x_i, \rho_l)) &= \frac{b^2}{2} \int_{B(0, \rho_l)} \left| \nabla \left(\frac{u_l}{b} \right) \right|^2 + \frac{b^2}{2\varepsilon_{n_l}^2} \left(1 - \left| \frac{u_l}{b} \right|^2 \right)^2 + o_l(1) \\ &= \frac{b^2}{2} \int_{B(0, bR_l)} |\nabla u_l'|^2 + \frac{1}{2} \left(1 - |u_l'|^2 \right)^2 + o_l(1) \\ &= \frac{b^2}{2} \int_{B(0, bR_l)} |\nabla u_0|^2 + \frac{1}{2} \left(1 - |u_0|^2 \right)^2 + o_l(1). \end{aligned}$$

From Proposition 3.11 in [19], one has

$$\frac{1}{2} \int_{B(0, bR_l)} |\nabla u_0|^2 + \frac{1}{2} \left(1 - |u_0|^2 \right)^2 = \pi \ln(bR_l) + \gamma + o_l(1),$$

hence

$$F_{\varepsilon_{n_l}}(v_l, B(x_i, \rho_l)) = b^2 [\pi \ln(bR_l) + \gamma] + o_l(1). \quad (4.33)$$

By combining (4.32) with (4.33), we obtain (4.22) with $\rho_l = R_l \varepsilon_{n_l}$.

4.6 Proof of Theorems 2 and 3

We prove the quantization part of Theorem 1 and Theorem 2:

- The existence of exactly d zeros is a direct consequence of Corollary 23.
- The fact that they are well included in ω_ε and that v_ε has a degree equal to 1 on small circles around the zeros are obtained by Proposition 22 and Corollary 23.
- The lower bound for $|v_\varepsilon|$ is given by Proposition 15.

Theorem 3 is obtained by combining:

- The weak H^1 -convergence of v_{ε_n} to v_* which is a direct consequence of Proposition 20 (this is explained right after Proposition 20).
- The behavior in an ε -neighborhood of the zeros of v_{ε_n} , given by (4.18) and Theorem 2 (combined with the main result of [18]).
- In the case where $\lambda \rightarrow 0$, the fact that we may localize the zeros inside the inclusions (microscopic location part of Theorem 1 and Theorem 4) is obtained via Theorem 4 in [12].

Indeed we take $f_n(x) = \text{tr}_{\partial B((k_n, l_n), \delta/2)} v_{\varepsilon_n}((k_n, l_n) + \delta x)$ with $(k_n, l_n) \in \delta \cdot \mathbb{Z}^2$ is a center of a cell containing a zero of v_{ε_n} . Using the main result of [17], one may easily prove that f_n satisfies the conditions (A1) and (A2). Thus we can apply Theorem 4 in [12] and infer that the location of the zero inside the inclusion is governed by a renormalized energy which is independent of the boundary condition.

- The macroscopic location part of Theorem 1 is a direct consequence of Proposition 15, (4.2), Corollary (26), (4.33) and Proposition 8.

A Proof of Proposition 2

We prove the existence of minimal map in \mathcal{I}_ρ and in \mathcal{J}_ρ . The main ingredient is the fact that these sets are closed under H^1 -weak convergence (see [15]). Thus, considering a minimizing sequence for $\frac{1}{2} \int_{\Omega_\rho} \alpha |\nabla \cdot|^2$ in above sets, we obtained the result.

We fix $\theta_0, \theta_i : \Omega_\rho \rightarrow \mathbb{R}$ some multivalued functions with smooth gradient s.t. $e^{i\theta_0} = \Pi_i \left(\frac{x-x_i}{|x-x_i|} \right)^{d_i}$ and $e^{i\theta_i} = \frac{x-x_i}{|x-x_i|}$. Here $d_i \in \mathbb{N}^*$, and they are given by the definition of \mathcal{I}_ρ or if we are considering the minimization in \mathcal{J}_ρ , then we have $d_i = 1$.

From Lemma 11 in [6], there is $\phi_0 \in C^\infty(\partial\Omega, \mathbb{R})$ s.t. $ge^{-i\theta_0} = e^{i\phi_0}$.

Note that

$$w \in \mathcal{I}_\rho \iff w = e^{i(\theta_0 + \phi)} \text{ with } \phi \in H^1(\Omega_\rho, \mathbb{R}) \text{ and } \text{tr}_{\partial\Omega} \phi = \phi_0, \quad (\text{A.1})$$

$$w \in \mathcal{J}_\rho \iff \begin{cases} w = e^{i(\theta_0 + \phi)} \text{ with } \phi \in H^1(\Omega_\rho, \mathbb{R}), \\ \sum_{j \neq i} \theta_j + \phi = \text{Cst}_i \text{ on } \partial B(x_i, \rho) \text{ and } \text{tr}_{\partial\Omega} \phi = \phi_0 \end{cases} \cdot \quad (\text{A.2})$$

Clearly, from (A.1) and (A.2), \mathcal{I}_ρ and in \mathcal{J}_ρ are H^1 -weakly closed.

We now prove the second part of Proposition 2.

One may easily obtain that for some $\lambda : \Omega_\rho \rightarrow \mathbb{R}$, denoting $w = e^{i(\theta_0 + \phi)}$, $\phi \in H^1(\Omega_\rho, \mathbb{R})$ (and thus $w \in \mathcal{I}_\rho$), we have

$$-\operatorname{div}(\alpha \nabla w) = \lambda w \iff \{-\operatorname{div}[\alpha \nabla(\theta_0 + \phi)] = 0 \text{ and } \lambda = \alpha |\nabla w|^2\}. \quad (\text{A.3})$$

This observation is a direct consequence of the following identity

$$-\operatorname{div} \left[\alpha \nabla e^{i(\theta_0 + \phi)} \right] = -\operatorname{div} [\alpha \nabla(\theta_0 + \phi)] i e^{i(\theta_0 + \phi)} + \alpha |\nabla(\theta_0 + \phi)|^2 e^{i(\theta_0 + \phi)}.$$

Note that under these notations one has $|\nabla w| = |\nabla(\theta_0 + \phi)|$. Thus w is a minimizer in \mathcal{I}_ρ or \mathcal{J}_ρ if and only if $\theta_0 + \phi$ minimizes the weighted Dirichlet functional under the condition fixed by the RHS of (A.1) or (A.2).

Consequently, we find that $\theta + \phi$ minimizes the weighted Dirichlet functional under its Dirichlet boundary condition.

Therefore, we obtain easily that $-\operatorname{div}[\alpha \nabla(\theta_0 + \phi)] = 0$. The identity $\nabla(\theta_0 + \phi) = w \times \nabla w$ yields $-\operatorname{div}(\alpha \nabla w) = \lambda w$.

Hence, the Euler-Lagrange equations in (3.1),(3.2) are direct consequences of (A.3).

The condition on the boundary for $w_{\rho, \alpha}^{\text{deg}}$ (resp. $w_{\rho, \alpha}^{\text{Dir}}$) follows from multiplying the equation satisfied by $\theta + \phi_{\rho, \alpha}^{\text{deg}}$, $w_{\rho, \alpha}^{\text{deg}} = e^{i(\theta + \phi_{\rho, \alpha}^{\text{deg}})}$ (resp. $\theta + \phi_{\rho, \alpha}^{\text{Dir}}$, $w_{\rho, \alpha}^{\text{Dir}} = e^{i(\theta + \phi_{\rho, \alpha}^{\text{Dir}})}$) by $\psi \in \mathcal{D}(\Omega, \mathbb{R})$ (resp. $\psi \in \mathcal{D}(\Omega, \mathbb{R})$ s.t $\psi \equiv \text{Cst}_i$ in $B(x_i, \rho)$).

Since α is sufficiently smooth, we can rewrite the Euler-Lagrange equation as

$$-\Delta \phi = \frac{\nabla \alpha \cdot \nabla(\phi + \theta)}{\alpha} \text{ with } \frac{\nabla \alpha \cdot \nabla(\phi + \theta)}{\alpha} \in L^2(\Omega_\rho).$$

So, by elliptic regularity $\phi_{\rho, \alpha}^{\text{deg}}, \phi_{\rho, \alpha}^{\text{Dir}} \in H^2(\Omega_\rho, \mathbb{R})$, and consequently $w_{\rho, \alpha}^{\text{deg}}, w_{\rho, \alpha}^{\text{Dir}} \in H^2(\Omega_\rho, \mathbb{S}^1)$.

B Proof of Proposition 3

We prove the existence of a minimizing configuration $\{\mathbf{x}, \mathbf{d}\} = \{(x_1, \dots, x_N), (d_1, \dots, d_n)\}$ for $I_{\rho, \alpha}$.

Let $(\{\mathbf{x}_n, \mathbf{d}_n\})_n$ be a minimizing sequence of configuration of $I_{\rho, \alpha}$, *i.e.*,

$$\inf_{\substack{w \in H^1(\Omega_\rho^n, \mathbb{S}^1) \text{ s.t.} \\ w = g \text{ in } \Omega' \setminus \overline{\Omega \cup \cup B(x_i^n, \rho)} \\ \text{deg}_{\partial B(x_i^n, \rho)}(w) = d_i^n \text{ for all } i}} \frac{1}{2} \int_{\Omega_\rho^n} \alpha |\nabla w|^2 \rightarrow I_{\rho, \alpha};$$

here $\Omega_\rho^n = \Omega' \setminus \overline{\cup B(x_i^n, \rho)}$.

Up to a subsequence, we have $N_n = N = \text{Cst}$, $\mathbf{d}_n = \mathbf{d} = \text{Cst}$ and $\mathbf{x}_n \rightarrow \mathbf{x}$ with $\mathbf{x} = (x_1, \dots, x_N)$ s.t. $\min_{i \neq j} |x_i - x_j| \geq 8\rho$.

Consider $w_n \in \mathcal{I}_\rho(\mathbf{x}_n, \mathbf{d})$ a minimizing map. Since w_n is bounded independently of n in $H^1(\Omega_\rho^n)$, up to a subsequence, we have $w_n \rightharpoonup w_0$ in $H_{\text{loc}}^1(\Omega_\rho^0)$, $\Omega_\rho^0 = \Omega' \setminus \overline{\cup B(x_i, \rho)}$.

Clearly the following properties hold:

- $w_0 \in H_{\text{loc}}^1(\Omega_\rho^0, \mathbb{S}^1)$ and $w_0 = g$ in $\Omega_\rho^0 \setminus \overline{\Omega}$.
- For all compact $K \subset \Omega_\rho^0$ we have $\frac{1}{2} \int_K \alpha |\nabla w_0|^2 \leq \liminf \frac{1}{2} \int_K \alpha |\nabla w_n|^2 \leq I_{\rho, \alpha}$.

Thus $w_0 \in H_g^1(\Omega_\rho^0, \mathbb{S}^1)$ and $\int_{\Omega_\rho^0} \alpha |\nabla w_0|^2 \leq I_{\rho, \alpha}$.

Now, it suffices to check that $\deg_{\partial B(x_i, \rho)}(w_0) \in \mathbb{N}^*$ for all i . Since w_0 is \mathbb{S}^1 -valued, this fact is equivalent to $\deg_{\partial B(x_i, \rho')}(w_0) \in \mathbb{N}^*$ for all i and for all $\rho' \in (\rho, 2\rho)$.

In view of the fact that for $\rho' \in (\rho, 2\rho)$ we have $w'_n = w_{n|\Omega' \setminus \overline{UB(x_i, \rho')}} \rightharpoonup w'_0 = w_{0|\Omega' \setminus \overline{UB(x_i, \rho')}}$ and on the other hand the set

$$\mathcal{I}' := \{w' \in H^1(\Omega' \setminus \overline{UB(x_i, \rho')}, \mathbb{S}^1) \mid \deg_{\partial B(x_i, \rho')}(w') = d_i \text{ for all } i \in \{1, \dots, N\}\}$$

is closed under the H^1 -weak convergence (see Appendix A or [15]), since $w'_n \in \mathcal{I}'$, we obtain that $w'_0 \in \mathcal{I}'$. Therefore $\{\mathbf{x}, \mathbf{d}\} = \{(x_1, \dots, x_N), (d_1, \dots, d_N)\}$ is a minimizing configuration for $I_{\rho, \alpha}$.

Now we prove the existence of a minimizing configuration for $J_{\rho, \alpha}$.

Let $(\mathbf{x}_n)_n$ be a minimizing sequence of configuration for $J_{\rho, \alpha}$, *i. e.*,

$$\hat{\mathcal{J}}_{\rho, \alpha}(\mathbf{x}_n, \mathbf{1}) \rightarrow J_{\rho, \alpha}.$$

Up to a subsequence, one may assume that there is $\mathbf{x} = (x_1, \dots, x_d) \in \Omega^d$ s.t. $x_i^n \rightarrow x_i$, $|x_i - x_j| \geq 8\rho$ and $\text{dist}(x_i, \partial\Omega) \geq \eta$.

Let $\eta_n = 8 \max |x_i^n - x_i|$. There is a smooth diffeomorphism $\phi_n : \mathbb{R}^2 \rightarrow \mathbb{R}^2$ satisfying

$$\begin{cases} \phi_n \equiv \text{Id}_{\mathbb{R}^2} & \text{in } \mathbb{R}^2 \setminus \overline{UB(x_i^n, \rho + \eta_n^{1/2})} \\ \phi_n [x_i + (1 + \eta_n)x] = x_i^n + x & \text{for } x \in B(0, \rho) \\ \|\phi_n - \text{Id}_{\mathbb{R}^2}\|_{C^1(\mathbb{R}^2)} = o_n(1) \end{cases}.$$

For example we can consider $\phi_n = \text{Id}_{\mathbb{R}^2} + H_n$ with

$$\begin{cases} H_n \equiv 0 & \text{in } \mathbb{R}^2 \setminus \overline{UB(x_i^n, \rho + \eta_n^{1/2})} \\ H_n [x_i + (1 + \eta_n)x] = (1 - \psi_n(|x|))(x_i^n - x_i - \eta_n x) & \text{for } x \in B(0, \frac{\rho + \eta_n^{1/2}}{1 + \eta_n}) \end{cases}.$$

Here $\psi_n : \mathbb{R}^+ \rightarrow [0, 1]$ is a smooth function satisfying

$$\psi_n(r) = \begin{cases} 0 & \text{if } r \leq \rho \\ 1 & \text{if } r \geq \rho + \eta_n^{1/2}/2 \end{cases} \text{ and } |\psi_n'| = \mathcal{O}(\eta_n^{-1/2}).$$

For $w_n \in \mathcal{J}_\rho(\mathbf{x}_n, \mathbf{1})$ a minimizing map, we consider

$$\begin{aligned} \tilde{w}_n : \Omega \setminus \cup_i \overline{B(x_i, (1 + \eta_n)\rho)} &\rightarrow \mathbb{S}^1 \\ x &\mapsto w_n[\phi_n(x)] \end{aligned}.$$

Clearly \tilde{w}_n is well defined and we have

$$\begin{aligned} \int_{\Omega \setminus \cup_i \overline{B(x_i, (1 + \eta_n)\rho)}} \alpha |\nabla \tilde{w}_n|^2 &= \int_{\Omega \setminus \cup_i \overline{B(x_i^n, \rho)}} \alpha |\nabla w_n|^2 + o_n(1), \\ \tilde{w}_n [x_i + (1 + \eta_n)\rho e^{i\theta}] &= w_n [\phi(x_i + (1 + \eta_n)\rho e^{i\theta})] = w_n [x_i^n + \rho e^{i\theta}] = e^{i(\theta + \theta_i)}. \end{aligned}$$

We can extend \tilde{w}_n in $\cup_i B(x_i, (1 + \eta_n)\rho) \setminus \overline{B(x_i, \rho)}$ by $\tilde{w}_n(x_i + re^{i\theta}) = e^{i(\theta + \theta_i)}$, $\rho < r < (1 + \eta_n)\rho$.

Clearly, we have $\tilde{w}_n \in \mathcal{J}_{\rho, \alpha}(\mathbf{x}, \mathbf{1})$ and $\frac{1}{2} \int_{\Omega \setminus \cup_i \overline{B(x_i, \rho)}} \alpha |\nabla \tilde{w}_n|^2 = J_{\rho, \alpha} + o_n(1)$.

Thus considering $w \in \mathcal{J}_{\rho, \alpha}(\mathbf{x}, \mathbf{1})$ a minimizer of $\frac{1}{2} \int_{\Omega \setminus \cup_i \overline{B(x_i, \rho)}} \alpha |\nabla \cdot|^2$, we obtain

$$\frac{1}{2} \int_{\Omega \setminus \cup_i \overline{B(x_i, \rho)}} \alpha |\nabla w|^2 \leq \frac{1}{2} \int_{\Omega \setminus \cup_i \overline{B(x_i, \rho)}} \alpha |\nabla \tilde{w}_n|^2 = J_{\rho, \alpha} + o_n(1).$$

Letting $n \rightarrow \infty$ we deduce that the configuration $\mathbf{x} = (x_1, \dots, x_d)$ is minimizing.

C Proof of Proposition 4

As explained in Section 3.2, Proposition 4 is easily established when either $N = 1$ or when the points are well separated. It remains to consider the case where $N \geq 2$ and there are $i \neq j$ s.t. $|x_i - x_j| \leq 4\eta_{\text{stop}}$.

C.1 The separation process

We assume that $N \geq 2$ and that the points are not well separated. Our purpose is to compare the energy of $\tilde{\mathcal{J}}_{\rho, \alpha}$ to the energy of $\hat{\mathcal{L}}_{\rho, \alpha}$. To this purpose, we decompose Ω_ρ into several regions and we compare energies in each region. These regions are constructed recursively using the following version of Theorem IV.1 in [4].

Lemma 27. *Let $N \geq 2$, $x_1, \dots, x_N \in \mathbb{R}^2$ and $\eta > 0$. There are $\kappa \in \{9^0, \dots, 9^{N-1}\}$ and $\{y_1, \dots, y_{N'}\} \subset \{x_1, \dots, x_N\}$ s.t.*

$$\cup_{i=1}^N B(x_i, \eta) \subset \cup_{i=1}^{N'} B(y_i, \kappa\eta)$$

and

$$|y_i - y_j| \geq 8\kappa\eta \text{ for } i \neq j.$$

We let x_1^0, \dots, x_N^0 denote the initial points x_1, \dots, x_N . For $k \geq 1$ (here, k is an iteration in the construction of the regions), we let N_k denote the number of points selected at Step k , and denote the points we select by $x_1^k, \dots, x_{N_k}^k$.

The recursive construction is made in such a way that $N_k > N_{k+1}$ and $N_k \geq 1$ for all $k \geq 1$.

The process will stop at the end of Step k if and only if one of the following conditions yields

Rule 1: there is a unique point in the selection (i.e. $N_k = 1$),

Rule 2: $\min_{i \neq j} |x_i^k - x_j^k| > 4\eta_{\text{stop}}$.

Step k , $k \geq 1$: Let $\eta'_k = \frac{1}{4} \min_{i \neq j} |x_i^{k-1} - x_j^{k-1}|$.

Using Lemma 27, there are

$$\kappa_k \in \{9^1, \dots, 9^{N_{k-1}-1}\} \text{ and } \{x_1^k, \dots, x_{N_k}^k\} \subset \{x_1^{k-1}, \dots, x_{N_{k-1}}^{k-1}\}$$

s.t.

$$\cup_i B(x_i^{k-1}, \eta'_k) \subset \cup_j B(x_j^k, \kappa_k \eta'_k) \text{ and } |x_i^k - x_j^k| \geq 8\kappa_k \eta'_k \text{ for } i \neq j.$$

We denote $\eta_k = 2\kappa_k\eta'_k$. We stop the construction if $N_k = 1$ (Rule 1) or if $\frac{1}{4} \min |x_i^{k-1} - x_j^{k-1}| > \eta_{\text{stop}}$ (Rule 2).

In Figure 3 and 4 both stop conditions are presented.

Claim:

- i. From the definitions of η'_k and η_k , we have $N_k < N_{k-1}$ and $\eta_{k-1} \leq \eta'_k < \eta_k$.
- ii. The balls $B(x_j^k, 2\eta_k)$ are disjoint.
- iii. Denoting $\Lambda_j^k \subset \{1, \dots, N_{k-1}\}$ the set of indices i s.t. $x_i^{k-1} \in B(x_j^k, \kappa_k\eta'_k)$, then for $i \in \Lambda_j^k$ we have $B(x_i^{k-1}, \eta'_k) \subset B(x_j^k, \kappa_k\eta'_k)$. Furthermore, by construction, $|x_i^{k-1} - x_j^{k-1}| \geq 4\eta'_k$.

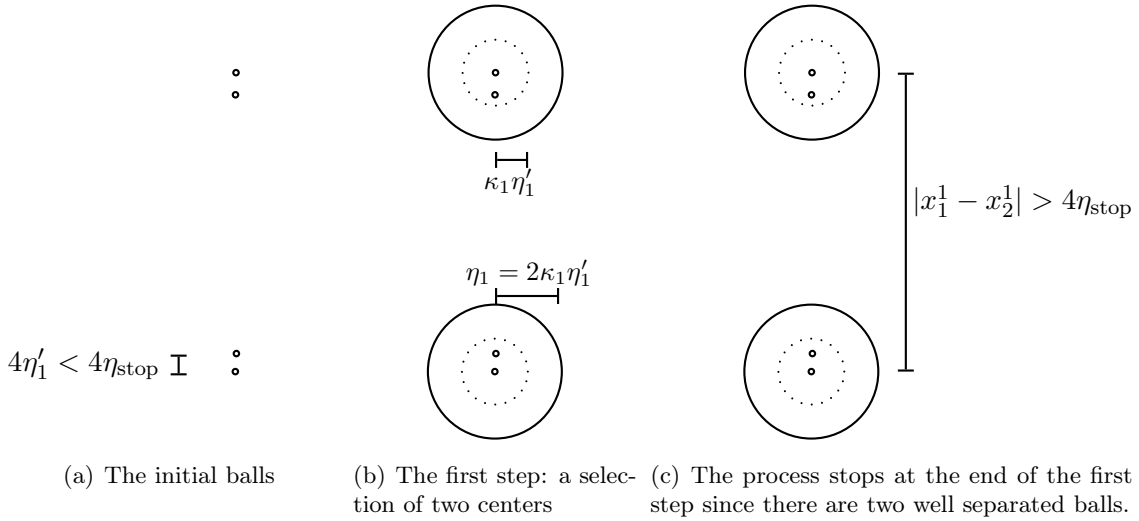

Figure 3: The process stops when we obtain well separated balls

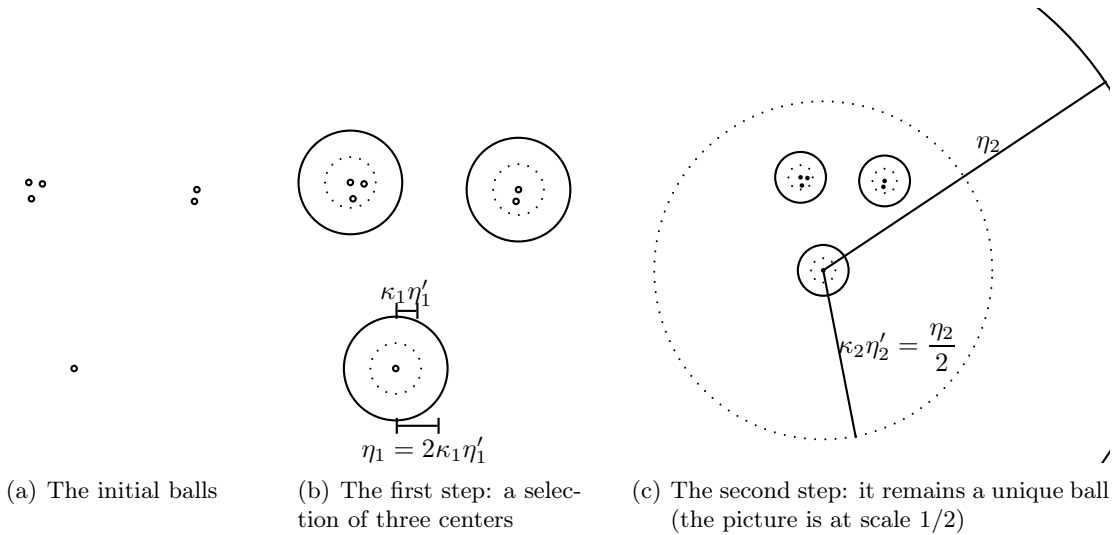

Figure 4: The process stops when we obtain a unique ball

C.2 The separation process gives a natural partition of Ω

Let $\Omega, g, x_1, \dots, x_N, \mathbf{d}$ and ρ, η_{stop} like in Section 3.2 with $N \geq 2$ and s.t. the points are not well separated.

We apply the separation process. The process stops after K steps, $1 \leq K \leq N - 1$.

We denote

$\{y_1, \dots, y_{N'}\} \subset \{x_1, \dots, x_N\}$ the selection that we obtain, *i.e.*, $x_j^K = y_j$ and $N' = N_K$,

$$\eta = \begin{cases} 9^N \cdot \eta_{\text{stop}} & \text{if } N' = 1 \\ \min \{9^N \cdot \eta_{\text{stop}}, \frac{1}{4} \min |y_i - y_j|\} & \text{if } N' > 1 \end{cases}, \text{ so } \eta \geq \max(\eta_K, \eta_{\text{stop}}), \quad (\text{C.1})$$

$$\Lambda_j = \{i \in \{1, \dots, N\} \mid x_i \in B(y_j, \eta)\}.$$

We denote

$$D_{j,k} = B(x_j^k, \eta_k) \setminus \cup_{x_i^{k-1} \in B(x_j^k, \eta_k)} B(x_i^{k-1}, \eta'_k), \quad k \in \{1, \dots, K\}, j \in \{1, \dots, N_k\}, \quad (\text{C.2})$$

$$R_{j,k} = B(x_j^k, \eta'_{k+1}) \setminus B(x_j^k, \eta_k), \quad k \in \{0, \dots, K-1\}, j \in \{1, \dots, N_k\}, \quad (\text{C.3})$$

$$R_j = B(y_j, \eta) \setminus B(y_j, \eta_K), \quad j \in \{1, \dots, N'\} \quad (\text{C.4})$$

and

$$D = \Omega \setminus \cup_{j \in \{1, \dots, N'\}} B(y_j, \eta).$$

Note that by construction of η'_k, η_k and x_i^k the following properties are satisfied:

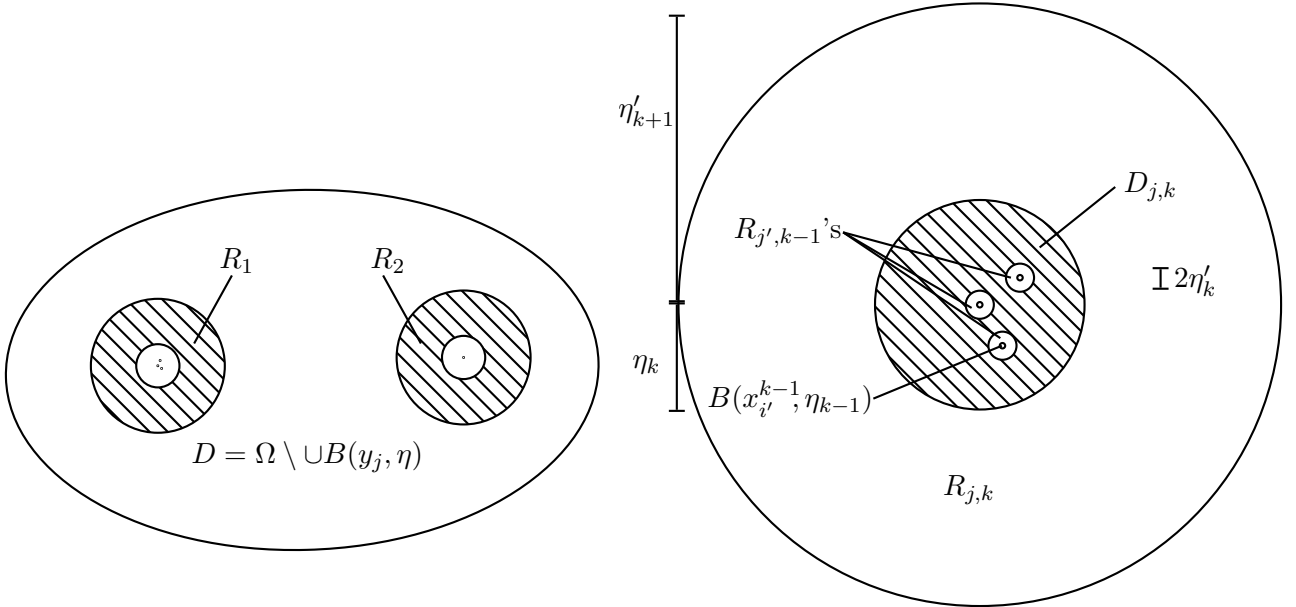

(a) The macroscopic perforated domain and the first mesoscopic rings (b) A mesoscopic ring and a mesoscopic perforated domain

$$\text{the balls } B(x_i^{k-1}, 2\eta'_k) \text{ are disjoint} \quad (\text{C.5})$$

and

$$2 \cdot 9\eta'_k \leq \eta_k \leq 9^N \eta'_k. \quad (\text{C.6})$$

Therefore

$$\Omega_\rho = D \bigcup \bigcup_{j,k} D_{j,k} \bigcup \bigcup_{j,k} R_{j,k} \bigcup \bigcup_j R_j \text{ with disjoint unions.} \quad (\text{C.7})$$

Construction of test functions in D and $D_{j,k}$

Lemma 28. *1. Let $\eta > 0$. There is $C_1(\eta, \Omega, g) > 0$ s.t. if $x_1, \dots, x_N \in \Omega$ satisfy $\min_{i \neq j} |x_i - x_j|, \min_i \text{dist}(x_i, \partial\Omega) > 4\eta$ and $d_1, \dots, d_N \in \mathbb{N}^*$ are s.t. $\sum d_i = d$ then there is $w \in H_g^1(\Omega_\eta, \mathbb{S}^1)$ s.t. $w(x) = \frac{(x-x_i)^{d_i}}{\eta^{d_i}}$ on $\partial B(x_i, \eta)$ and*

$$\int_{\Omega_\eta} |\nabla w|^2 \leq C_1(\eta).$$

Moreover C_1 can be considered decreasing with η .

2. Let $\eta > 0, \kappa \geq 8, d_0, d_1, \dots, d_N \in \mathbb{N}^$ be s.t. $\sum_{1 \leq i \leq N} d_i = d_0$. Then, there is $C_2(\kappa, d_0)$ s.t. $x_1, \dots, x_N \in B(0, \kappa\eta)$ satisfying $\min_{i \neq j} |x_i - x_j| \geq 4\eta$ we can associate a map to each family $w \in H^1(B(0, 2\kappa\eta) \setminus \cup \overline{B(x_i, \eta)}, \mathbb{S}^1)$ s.t.*

$$w(x) = \begin{cases} \frac{x^{d_0}}{(2\kappa\eta)^{d_0}} & \text{on } \partial B(0, 2\kappa\eta) \\ \frac{(x-x_i)^{d_i}}{\eta^{d_i}} & \text{on } \partial B(x_i, \eta) \end{cases}$$

and

$$\int_{B(0, 2\kappa\eta) \setminus \cup \overline{B(x_i, \eta)}} |\nabla w|^2 \leq C_2(\kappa, d_0).$$

Moreover C_2 can be considered increasing with κ, d_0 .

Proof. In order to prove 1., we consider, e.g., the test function

$$w = e^{iH} \prod_i \frac{(x-x_i)^{d_i}}{|x-x_i|^{d_i}} \text{ with } H \text{ s.t. } \begin{cases} H : \Omega_\eta \rightarrow \mathbb{R} \\ H \equiv 0 \text{ in } \left\{ \text{dist} \left[x, \partial \left(\Omega \setminus \overline{B(x_i, \eta)} \right) \right] \geq \eta \right\} \\ -\Delta H = 0 \text{ in } \left\{ \text{dist} \left[x, \partial \left(\Omega \setminus \overline{B(x_i, \eta)} \right) \right] < \eta \right\} \\ w \in H_g^1(\Omega_\eta, \mathbb{S}^1) \text{ and } w(x) = \frac{(x-x_i)^{d_i}}{\eta^{d_i}} \text{ on } \partial B(x_i, \eta) \end{cases}.$$

Assertion 2. was essentially established in [13], Section 3. We adapt here the argument in [13]. By conformal invariance, we may assume that $\eta = 1$. We let

$$w(x) = \begin{cases} \prod_i \frac{\left[x + 2x_i \left(\frac{|x|}{\kappa} - 2 \right) \right]^{d_i}}{\left| x + x_i \left(\frac{|x|}{\kappa} - 2 \right) \right|^{d_i}} & \text{in } B(0, 2\kappa) \setminus \overline{B(0, \frac{3\kappa}{2})} \\ \prod_i \frac{(x-x_i)^{d_i}}{|x-x_i|^{d_i}} & \text{in } B(0, \frac{3\kappa}{2}) \setminus \cup \overline{B(x_i, 3/2)}; \\ \frac{(x-x_i)^{d_i}}{|x-x_i|^{d_i}} e^{i(2|x-x_i|-2)\varphi_i} & \text{in } B(x_i, 3/2) \setminus \cup \overline{B(x_i, 1)} \end{cases}$$

here $\varphi_i \in C^\infty(B(x_i, 3/2) \setminus \overline{\cup B(x_i, 1)}, \mathbb{R})$ is defined by $e^{i\varphi_i} = \prod_{j \neq i} \frac{(x - x_j)^{d_j}}{|x - x_j|^{d_j}}$. Clearly $\|\varphi_i\|_{H^1(B(x_i, 3/2) \setminus \overline{\cup B(x_i, 1)})}$ is bounded by a constant which depends only on d_0 . \square

By (C.1) and Lemma 28, part 1., one may find a map $w_0 \in H^1(D, \mathbb{S}^1)$ s.t.

$$w_0 = \begin{cases} g & \text{on } \partial\Omega \\ w_0(x) = \frac{(x - y_j)^{\tilde{d}_j}}{\eta^{\tilde{d}_j}} & \text{on } \partial B(y_j, \eta) \end{cases} \quad (\text{where } \tilde{d}_j = \sum_{x_i \in B(y_j, \eta)} d_i)$$

satisfying in addition

$$\int_D |\nabla w_0|^2 \leq C_1(\eta) \leq C_1(\eta_{\text{stop}}). \quad (\text{C.8})$$

For each $D_{j,k}$, combining (C.2), (C.5), (C.6) and using Lemma 28, part 2, there exists a map $w_{j,k} \in H^1(D_{j,k}, \mathbb{S}^1)$ s.t.

$$w_{j,k}(x) = \begin{cases} \frac{(x - x_j^k)^{\tilde{d}_{j,k}}}{\eta_k^{\tilde{d}_{j,k}}} & \text{for } x \in \partial B(x_j^k, \eta_k) \\ \frac{(x - x_i^{k-1})^{\tilde{d}_{i,k-1}}}{\eta_k^{\tilde{d}_{i,k-1}}} & \text{for } x \in \partial B(x_i^{k-1}, \eta_k') \end{cases}.$$

Here,

$$\tilde{d}_{j,k} = \sum_{x_i \in B(x_j^k, \eta_k)} d_i$$

and

$$\int_{D_{j,k}} |\nabla w_{j,k}|^2 \leq C_2(2\kappa_k, d_{j,k}) \leq C_2(2 \cdot 9^{d-1}, d). \quad (\text{C.9})$$

Construction of test functions in R_j 's and $R_{j,k}$'s

For $R > r > 0$ and $x_0 \in \mathbb{R}^2$ we denote $\mathcal{R}(x_0, R, r) := B(x_0, R) \setminus \overline{B(x_0, r)}$. For $\alpha \in L^\infty(\mathbb{R}^2, [b^2, 1])$, we define

$$\mu_\alpha(\mathcal{R}(x_0, R, r), \tilde{d}) = \inf_{\substack{w \in H^1(\mathcal{R}(x_0, R, r), \mathbb{S}^1) \\ \deg_{\partial B(x_0, R)}(w) = \tilde{d}}} \frac{1}{2} \int_{\mathcal{R}(x_0, R, r)} \alpha |\nabla w|^2 \quad (\text{C.10})$$

and

$$\mu_\alpha^{\text{Dir}}(\mathcal{R}(x_0, R, r), \tilde{d}) = \inf_{\substack{w \in H^1(B(x_0, R) \setminus \overline{B(x_0, r)}, \mathbb{S}^1) \\ w(x_0 + Re^{i\theta}) = e^{i\tilde{d}\theta} \\ w(x_0 + re^{i\theta})e^{-i\tilde{d}\theta} = \text{Cst}}} \frac{1}{2} \int_{B(x_0, R) \setminus \overline{B(x_0, r)}} \alpha |\nabla w|^2. \quad (\text{C.11})$$

In the special case $\alpha = U_\varepsilon^2$, we denote

$$\mu_\varepsilon(\mathcal{R}(x_0, R, r), \tilde{d}) = \mu_{U_\varepsilon^2}(\mathcal{R}(x_0, R, r), \tilde{d})$$

and

$$\mu_\varepsilon^{\text{Dir}}(\mathcal{R}(x_0, R, r), \tilde{d}) = \mu_{U_\varepsilon^2}^{\text{Dir}}(\mathcal{R}(x_0, R, r), \tilde{d}).$$

Note that the minimization problems (C.10) and (C.11) admit solutions; this is obtained by adapting the proof of Proposition 2.

If α is Lipschitz, then the solutions of (C.10) and (C.11) are in H^2 .

We present an adaptation of a result of Sauvageot, Theorem 2 in [20].

Proposition 29. *There is $C_b > 0$ depending only on $b \in (0, 1)$ s.t. for $R > r > 0$ and $\alpha \in L^\infty(\mathbb{R}^2, \mathbb{R})$ satisfying $1 \geq \alpha \geq b^2$, we have*

$$\mu_\alpha^{\text{Dir}}(\mathcal{R}(x_0, R, r), \tilde{d}) \leq \mu_\alpha(\mathcal{R}(x_0, R, r), \tilde{d}) + \tilde{d}^2 C_b.$$

Proof. This result was obtained by Sauvageot with $\alpha \in W^{1,\infty}(\mathbb{R}^2, [b^2, 1])$. We may extend this estimate to $\alpha \in L^\infty(\mathbb{R}^2, [b^2, 1])$.

Indeed, let $(\rho_t)_{1>t>0}$ be a classical mollifier, namely $\rho_t(x) = t^{-2}\rho(x/t)$ with $\rho \in C^\infty(\mathbb{R}^2, [0, 1])$, $\text{Supp } \rho \subset B(0, 1)$ and $\int_{\mathbb{R}^2} \rho = 1$.

Set $\alpha_t = \alpha * \rho_t \in W^{1,\infty}(B(x_0, R), [b^2, 1])$. We have

$$\lim_{t \rightarrow 0} \mu_{\alpha_t}(\mathcal{R}(x_0, R, r), \tilde{d}) = \mu_\alpha(\mathcal{R}(x_0, R, r), \tilde{d}) \quad (\text{C.12})$$

and

$$\lim_{t \rightarrow 0} \mu_{\alpha_t}^{\text{Dir}}(\mathcal{R}(x_0, R, r), \tilde{d}) = \mu_\alpha^{\text{Dir}}(\mathcal{R}(x_0, R, r), \tilde{d}). \quad (\text{C.13})$$

We prove (C.12), Equality (C.13) follows with the same lines.

Let w be a minimizer of $\mu_\alpha(\mathcal{R}(x_0, R, r), \tilde{d})$. By using Dominated convergence theorem, since $\alpha_t \rightarrow \alpha$ in $L^1(B(x_0, R))$, we obtain that $\alpha_t |\nabla w|^2 \rightarrow \alpha |\nabla w|^2$ in $L^1(\mathcal{R}(x_0, R, r))$ as $t \rightarrow 0$. Consequently

$$\lim_{t \rightarrow 0} \mu_{\alpha_t}(\mathcal{R}(x_0, R, r), \tilde{d}) \leq \mu_\alpha(\mathcal{R}(x_0, R, r), \tilde{d}).$$

On the other hand, let w_t be a minimizer of $\mu_{\alpha_t}(\mathcal{R}(x_0, R, r), \tilde{d})$ and let $t_n \downarrow 0$. Up to a subsequence, $w_{t_n} \rightharpoonup w_0$ in $H^1(\mathcal{R}(x_0, R, r))$ as $n \rightarrow \infty$ and $\sqrt{\alpha_{t_n}} \nabla w_{t_n} \rightharpoonup \sqrt{\alpha} \nabla w_0$ in $L^2(\mathcal{R}(x_0, R, r))$.

Since the class $\mathcal{I} := \{w \in H^1(\mathcal{R}(x_0, R, r), \mathbb{S}^1) \mid \deg_{B(x_0, R)}(w) = \tilde{d}\}$ is closed under the H^1 -weak convergence (see Appendix A or [15]), we obtain that $w_0 \in \mathcal{I}$. Consequently, we have

$$\liminf_{t \rightarrow 0} \mu_{\alpha_t}(\mathcal{R}(x_0, R, r), \tilde{d}) \geq \mu_\alpha(\mathcal{R}(x_0, R, r), \tilde{d}).$$

Thus the proof of (C.12) is complete.

Therefore, without loss of generality, we may assume that α is Lipschitz.

One may easily prove that if $R \leq 4r$, then $\mu_\alpha^{\text{Dir}}(\mathcal{R}(x_0, R, r), \tilde{d}) \leq 2\tilde{d}^2 \pi \ln 4$. Thus we assume that $R > 4r$. Clearly, it suffices to obtain the result for $\tilde{d} = 1$ and $x_0 = 0$.

Let w be a global minimizer of $\mu_\alpha(\mathcal{R}(x_0, R/2, 2r), 1)$. As explained in Section A, denoting $x/|x| = e^{i\theta}$, one may write $w = e^{i(\theta+\phi)}$ for some $\phi \in H^2(\mathcal{R}(x_0, R/2, 2r), \mathbb{R})$. Now we switch to polar coordinates.

Consider

$$I = \left\{ \rho \in [2r, R/2] \mid \int_0^{2\pi} \alpha |\nabla(\theta + \phi)|^2(\rho, \theta) d\theta \leq \frac{1}{\rho^2} \int_0^{2\pi} \alpha(\rho, \theta) d\theta \right\}.$$

Then I is closed (since $\phi \in H^2$). On the other hand, I is non empty, by the mean value theorem.

Let $r_1 = \min I$ and $r_2 = \max I$. We may assume that $\phi(r_2, 0) = 0$ and $\phi(r_1, 0) = \theta_0$. We construct a test function:

$$\phi'(\rho, \theta) = \begin{cases} 0 & \text{if } 2r_2 \leq \rho \leq R \\ \frac{2r_2 - \rho}{r_2} \phi(r_2, \theta) & \text{if } r_2 \leq \rho \leq 2r_2 \\ \phi(\rho, \theta) & \text{if } r_1 \leq \rho \leq r_2 \\ \frac{2\rho - r_1}{r_1} \phi(r_1, \theta) + 2\frac{r_1 - \rho}{r_1} \theta_0 & \text{if } r_1/2 \leq \rho \leq r_1 \\ \theta_0 & \text{if } r \leq \rho \leq r_1/2 \end{cases}.$$

As explained in [20], there is C depending only on b s.t.

$$\frac{1}{2} \int_{B(0, R/2) \setminus \overline{B(0, 2r)}} \alpha (|\nabla(\theta + \phi')|^2 - |\nabla(\theta + \phi)|^2) \leq C.$$

Thus the result follows. \square

As a direct consequence of Proposition 29 (the two first assertions of the next proposition are direct), we have

Proposition 30. *Let $\alpha \in L^\infty(\mathbb{R}^2, [b^2, 1])$, $R > r_1 > r > 0$, $\tilde{d} \in \mathbb{Z}$ and $x_0 \in \mathbb{R}^2$, we have*

1. $\mu_\alpha(\mathcal{R}(x_0, R, r), \tilde{d}) = \tilde{d}^2 \mu_\alpha(\mathcal{R}(x_0, R, r), 1)$,
2. $b^2 \pi \ln \frac{R}{r} \leq \mu_\alpha(\mathcal{R}(x_0, R, r), 1) \leq \pi \ln \frac{R}{r}$,
3. $\mu_\alpha(\mathcal{R}(x_0, R, r), 1) \leq \mu_\alpha(\mathcal{R}(x_0, R, r_1), 1) + \mu_\alpha(\mathcal{R}(x_0, r_1, r), 1) + 2C_b$ where C_b is given by Proposition 29 and depending only on b .

For $\alpha \in L^\infty(\Omega, [b^2, 1])$, using Proposition 29, there is C_b depending only on $b \in (0, 1)$ s.t. for all $k \in \{1, \dots, K-1\}$, $j \in \{1, \dots, N_k\}$, there is $w_{\varepsilon, j, k} \in H^1(R_{j, k}, \mathbb{S}^1)$ s.t.

$$w_{\alpha, j, k}(x) = \begin{cases} \frac{(x - x_j^k)^{\tilde{d}_{j, k}}}{\eta'_{k+1}} & \text{for } x \in \partial B(x_j^k, \eta'_{k+1}) \\ \gamma_{\alpha, j, k} \frac{(x - x_j^k)^{\tilde{d}_{j, k}}}{\eta_k} & \text{for } x \in \partial B(x_j^k, \eta_k) \text{ where } \gamma_{\alpha, j, k} \in \mathbb{S}^1 \end{cases}$$

and s.t. for all $w \in H^1(R_{j, k}, \mathbb{S}^1)$ satisfying $\deg_{\partial B(x_j^k, \eta_k)}(w) = \tilde{d}_{j, k}$ one has

$$\int_{R_{j, k}} \alpha |\nabla w_{\alpha, j, k}|^2 \leq \int_{R_{j, k}} \alpha |\nabla w|^2 + C_b \tilde{d}_{j, k}^2 \leq \int_{R_{j, k}} \alpha |\nabla w|^2 + C_b d^2. \quad (\text{C.14})$$

Now we consider the rings R_j . For $j \in \{1, \dots, N'\}$, we denote

$$\tilde{d}_j = \sum_{x_i \in B(y_j, \eta)} d_i.$$

Using Proposition 29, for $j \in \{1, \dots, N'\}$, we obtain $w_{\alpha, j} \in H^1(R_j, \mathbb{S}^1)$ s.t.

$$w_{\alpha, j}(x) = \begin{cases} \frac{(x - y_j)^d}{\eta^d} & \text{for } x \in \partial B(y_j, \eta) \\ \gamma_{\alpha, j} \frac{(x - y_j)^d}{\eta_K^d} & \text{for } x \in \partial B(y_j, \eta_K) \text{ where } \gamma_{\alpha, j} \in \mathbb{S}^1 \end{cases}$$

and s.t. for all $w \in H^1(R_j, \mathbb{S}^1)$ satisfying $\deg_{\partial B(y_j, \eta)}(w) = \tilde{d}_j$ one has

$$\int_{R_j} \alpha |\nabla w_{\alpha, j}|^2 \leq \int_{R_j} \alpha |\nabla w|^2 + C_b d^2. \quad (\text{C.15})$$

C.3 Proof of Proposition 4

Note that there are at most d^2 regions $D_{j,k}$, at most d^2 rings $R_{j,k}$ and at most d rings R_j . Consequently, denoting

$$C_4 = C_4(g, \Omega, b, \eta_{\text{stop}}) = C_1(\eta_{\text{stop}}, g, \Omega) + d^2 C_2(2 \cdot 9^{d-1}, d) + 2d^2 C_b d^2$$

and using (C.7), (C.8), (C.9), (C.14), (C.15), one may construct a test function $w_\alpha \in \mathcal{J}_\rho$ (up to multiply by some \mathbb{S}^1 -Constants each function previously constructed) s.t. for all $w \in \mathcal{I}_\rho$, one has

$$\int_{\Omega_\rho} \alpha |\nabla w_\alpha|^2 \leq \int_{\Omega_\rho} \alpha |\nabla w|^2 + C_4. \quad (\text{C.16})$$

Clearly, (C.16) allows us to prove Proposition 4 with $C_0 = C_4/2$.

D Proof of Proposition 5

D.1 Description of the special solution U_ε

From Proposition 1, we know that far away $\partial\omega_\varepsilon$, U_ε is uniformly close to a_ε . Here we prove that, in a neighborhood of $\partial\omega_\varepsilon$, U_ε is very close to a cell regularization of a_ε .

Let

$$\begin{aligned} a^\lambda : Y = \left(-\frac{1}{2}, \frac{1}{2}\right) \times \left(-\frac{1}{2}, \frac{1}{2}\right) &\rightarrow \{b, 1\} \\ x &\mapsto \begin{cases} b & \text{if } x \in \omega^\lambda = \lambda \cdot \omega \\ 1 & \text{otherwise} \end{cases} \end{aligned}$$

Consider V_ξ the unique minimizer of

$$E_\xi^{a^\lambda}(V, Y) = \frac{1}{2} \int_Y |\nabla V|^2 + \frac{1}{2\xi^2} (a^\lambda - V)^2, V \in H_1^1(Y, \mathbb{R}). \quad (\text{D.1})$$

Lemma 31. *We have the existence of $C, \gamma > 0$ s.t. for $\varepsilon > 0$ and $x \in Y$*

$$|U_\varepsilon[y_{i,j}^\varepsilon + \delta^j x] - V_{\varepsilon/\delta^j}(x)| \leq C e^{-\frac{\gamma \delta^j}{\varepsilon}}.$$

Thus in the periodic case, we have U_ε which is almost a $\delta \cdot (\mathbb{Z} \times \mathbb{Z})$ -periodic function in $\Omega_\delta^{\text{incl}}$ in the sense that

$$|U_\varepsilon(x) - U_\varepsilon[x + (\delta k, \delta l)]| \leq C e^{-\frac{\gamma \delta}{\varepsilon}} \text{ if } x, x + (\delta k, \delta l) \in \Omega_\delta^{\text{incl}} \text{ and } k, l \in \mathbb{Z}.$$

Proof. Step 1. We first prove that, for all $s > 0$ and for sufficiently small ε , we have $U_\varepsilon^2 \geq \frac{b^2 + 1}{2} - s$ in $\Omega \setminus \omega_\varepsilon$. The same argument leads to $U_\varepsilon^2 \leq \frac{b^2 + 1}{2} + s$ in $\overline{\omega_\varepsilon}$ and for sufficiently small ξ : $V_\xi^2 \geq \frac{b^2 + 1}{2} - s$ in $Y \setminus \omega^\lambda$ and $V_\xi^2 \leq \frac{b^2 + 1}{2} + s$ in ω^λ .

From Proposition 1, it suffices to prove that for

$$R \geq \alpha^{-1} \ln \frac{C}{1 - \sqrt{\frac{1+b^2}{2}}},$$

we have $U_\varepsilon \geq \frac{1+b^2}{2} - s$ in $\{x \in \mathbb{R}^2 \mid \text{dist}(x, \partial\omega_\varepsilon) < R\varepsilon\}$. Here $C > 1, \alpha > 0$ are given by (1.5).

We fix $0 < s < 1$ and we prove that for $\varepsilon = \varepsilon_n \downarrow 0$, up to pass to a subsequence, we have $U_\varepsilon^2 \geq \frac{b^2+1}{2} - s$ in $\{x \in \mathbb{R}^2 \mid \text{dist}(x, \partial\omega_\varepsilon) < R\varepsilon\}$.

Let $z_\varepsilon = y_{i,j}^\varepsilon + \lambda\delta^j z_\varepsilon^0 \in \partial\omega_\varepsilon$, $z_\varepsilon^0 \in \partial\omega$ and for $x \in B(z_\varepsilon, \lambda\delta^{K+1})$, we write $x = z_\varepsilon + \varepsilon\tilde{x}$ with $\tilde{x} \in B(0, \lambda\delta^{K+1}/\varepsilon)$. We define

$$\begin{aligned} \tilde{U}_\varepsilon(\tilde{x}) : B(0, \lambda\delta^{K+1}/\varepsilon) &\rightarrow [b, 1] \\ \tilde{x} &\mapsto U_\varepsilon(z_\varepsilon + \varepsilon\tilde{x}). \end{aligned}$$

It is easy to check that

$$\begin{cases} -\Delta\tilde{U}_\varepsilon = \tilde{U}_\varepsilon(\tilde{a}_\varepsilon^2 - \tilde{U}_\varepsilon^2) & \text{in } B(0, \lambda\delta^{K+1}/\varepsilon) \\ \tilde{U}_\varepsilon \in H^1 \cap L^\infty(B(0, \lambda\delta^{K+1}/\varepsilon), [b, 1]) \end{cases} \quad (\text{D.2})$$

where

$$\tilde{a}_\varepsilon = \begin{cases} b & \text{in } \frac{\omega_\varepsilon - z_\varepsilon}{\varepsilon} \cap B(0, \lambda\delta^{K+1}/\varepsilon) \\ 1 & \text{in } \frac{(\mathbb{R}^2 \setminus \omega_\varepsilon) - z_\varepsilon}{\varepsilon} \cap B(0, \lambda\delta^{K+1}/\varepsilon) \end{cases}.$$

Clearly

$$\begin{aligned} \frac{\omega_\varepsilon - z_\varepsilon}{\varepsilon} \cap B(0, \lambda\delta^{K+1}/\varepsilon) &= \left[\frac{\lambda\delta^j}{\varepsilon} \cdot (\omega - z_\varepsilon^0) \right] \cap B(0, \lambda\delta^{K+1}/\varepsilon) \\ &= \frac{\lambda\delta^j}{\varepsilon} \cdot [(\omega - z_\varepsilon^0) \cap B(0, \delta^{K+1-j})], \end{aligned}$$

and thus

$$\frac{(\mathbb{R}^2 \setminus \omega_\varepsilon) - z_\varepsilon}{\varepsilon} \cap B(0, \lambda\delta^{K+1}/\varepsilon) = \frac{\lambda\delta^j}{\varepsilon} \cdot \{[(\mathbb{R}^2 \setminus \omega) - z_\varepsilon^0] \cap B(0, \delta^{K+1-j})\}.$$

Note that $\lambda\delta^{K+1}/\varepsilon \rightarrow \infty$ and $\delta^{K+1-j} \rightarrow 0$, thus by smoothness of ω , up to a subsequence, we have $\frac{\lambda\delta^j}{\varepsilon} \cdot \{[(\mathbb{R}^2 \setminus \omega) - z_\varepsilon^0] \cap B(0, \delta^{K+1-j})\} \rightarrow \mathcal{R}_{\theta_0}(\mathbb{R} \times \mathbb{R}^+)$. Here \mathcal{R}_{θ_0} is the vectorial rotation of angular $\theta_0 \in [0, 2\pi)$.

For sake of simplicity, we assume that $\theta_0 = 0$.

From (D.2) and standard elliptic estimates, we obtain that \tilde{U}_ε is bounded in $W^{2,p}(B(0, R))$ for $p \geq 2, R > 0$, thus up to consider a subsequence, we obtain that $\tilde{U}_\varepsilon \rightarrow \tilde{U}_b$ in $C_{\text{loc}}^1(\mathbb{R}^2)$ where $\tilde{U}_b \in C^1(\mathbb{R}^2, [b, 1])$ is a solution of

$$\begin{cases} -\Delta\tilde{U}_b = \tilde{U}_b(1 - \tilde{U}_b^2) & \text{in } \mathbb{R} \times \mathbb{R}^+ \\ -\Delta\tilde{U}_b = \tilde{U}_b(b^2 - \tilde{U}_b^2) & \text{in } \mathbb{R} \times \mathbb{R}^- \\ \tilde{U}_b \in C^1(\mathbb{R}^2) \cap H_{\text{loc}}^2(\mathbb{R}^2) \cap L^\infty(\mathbb{R}^2) \end{cases} \quad (\text{D.3})$$

It is proved in [14] (Theorem 2.2), that (D.3) admits a unique positive solution. Moreover $\tilde{U}_b(x, y) = U_b(y)$ (\tilde{U}_b is independent of its first variable) and U_b is **the unique** solution of

$$\begin{cases} -U_b'' = U_b(1 - U_b^2) & \text{in } \mathbb{R}^+ \\ -U_b'' = U_b(b^2 - U_b^2) & \text{in } \mathbb{R}^- \\ U_b \in C^1(\mathbb{R}, \mathbb{R}), U_b' > 0, \lim_{+\infty} U_b = 1, \lim_{-\infty} U_b = b \end{cases}.$$

This solution U_b may be explicitly obtained by looking for U_b under the form

$$U_b(x) = \begin{cases} \frac{Ae^{\sqrt{2}x} - 1}{Ae^{\sqrt{2}x} + 1} & \text{if } x \geq 0 \\ b \frac{Be^{-b\sqrt{2}x} - 1}{Be^{-b\sqrt{2}x} + 1} & \text{if } x < 0 \end{cases}.$$

We get $B = -\frac{3b^2 + 1 + 2b\sqrt{2(b^2 + 1)}}{1 - b^2}$, $A = \frac{B(1 + b) + 1 - b}{B(1 - b) + 1 + b}$ and

$$U_b(0) = b \frac{B - 1}{B + 1} = \frac{1 + b^2 + b\sqrt{2(b^2 + 1)}}{2b + \sqrt{2(b^2 + 1)}} = \frac{1 - b^2}{2b + \sqrt{2(b^2 + 1)}} + b = \sqrt{\frac{b^2 + 1}{2}}$$

Since $U_b(0)^2 \geq \frac{b^2 + 1}{2}$ and U_b is an increasing function, for $x \geq 0$, $U_b(x)^2 \geq \frac{b^2 + 1}{2}$. From the convergence $\tilde{U}_\varepsilon \rightarrow \tilde{U}_b$ in $L^\infty(B(0, R))$, we obtain that, for ε sufficiently small, $\tilde{U}_\varepsilon^2 \geq \frac{b^2 + 1}{2} - s$ in $B(0, R) \cap \left\{ \frac{\lambda \delta^j}{\varepsilon} \cdot [(\mathbb{R}^2 \setminus \omega) - z_\varepsilon^0] \right\}$.

Step 2. Fix $j \in \{1, \dots, P\}$ s.t. $\mathcal{M}_j^\varepsilon \neq \emptyset$ and fix $i \in \mathcal{M}_j^\varepsilon$. We denote $\xi := \frac{\delta^j}{\varepsilon}$. For $x \in Y$, consider $W(x) = V_\xi(x) - U_\varepsilon(y_{i,j}^\varepsilon + \delta^j x)$ which satisfies (using (1.5))

$$\begin{cases} -\xi^2 \Delta W(x) = W(x) \left\{ a^\lambda(x)^2 - [V_\xi(x)^2 + U_\varepsilon(y_{i,j}^\varepsilon + \delta^j x)V_\xi(x) + U_\varepsilon(y_{i,j}^\varepsilon + \delta^j x)^2] \right\} & \text{in } Y \\ 0 \leq W \leq Ce^{-\frac{\gamma}{\xi}} & \text{on } \partial Y \end{cases}.$$

By Step 1, taking $s = b^2$, for sufficiently small ε , we have for $x \in Y \setminus \omega^\lambda$

$$U_\varepsilon^2(y_{i,j}^\varepsilon + \delta^j x), V_\xi^2(x) \geq \max\left(b^2, \frac{1 - b^2}{2}\right) \geq \frac{1}{3}.$$

Thus, using the weak maximum principle, we find that $W \geq 0$ in Y . Consequently, since W is subharmonic, we deduce that $W \leq Ce^{-\frac{\gamma}{\xi}}$. \square

D.2 Behavior of almost minimizers of $I_{\rho, \varepsilon}$

We recall that for $x_0 \in \mathbb{R}^2$ and $R > r_1 > r > 0$, we denoted $\mathcal{R}(x_0, R, r) := B(x_0, R) \setminus \overline{B(x_0, r)}$.

D.2.1 Useful results for the periodic situation

We establish two preliminary results for the periodic situation represented Figure 1 (Propositions 30 and 33 below). Thus in this subsection we assume that U_ε is **the unique** global minimizer of E_ε in H_1^1 with the periodic pinning term a_ε represented Figure 1.

Energetic estimates in rings and global energetic upper bounds

From Lemma 31 (U_ε is close to a periodic function) we obtain the next result.

Lemma 32. *For all $1 \geq R > r \geq \varepsilon$, $x, x_0 \in \mathbb{R}^2$ s.t. $B(x_0, R) \subset \Omega_\delta^{\text{incl}}$ and $x - x_0 \in \delta \cdot \mathbb{Z}^2$, we have*

$$\mu_\varepsilon(\mathcal{R}(x, R, r), 1) \geq \mu_\varepsilon(\mathcal{R}(x_0, R, r), 1) - o_\varepsilon(1).$$

Adding the condition that $B(x, R) \subset \Omega_\delta^{\text{incl}}$, we have

$$|\mu_\varepsilon(\mathcal{R}(x, R, r), 1) - \mu_\varepsilon(\mathcal{R}(x_0, R, r), 1)| \leq o_\varepsilon(1).$$

Moreover the $o_\varepsilon(1)$ may be considered independent of x, x_0, R, r .

Lemma 32 implies the following

Proposition 33. *Let $\eta > 0$ and $\eta > \rho \geq \varepsilon$. Then there is $C = C(\Omega, \Omega', g, b, \eta) > 0$ s.t. for $x_0 \in \mathbb{R}^2$ we have*

$$I_{\rho, \varepsilon} \leq d \mu_\varepsilon(\mathcal{R}(x_0, \eta, \rho), 1) + C(\eta),$$

where $C(\eta)$ is a constant independent of x_0 .

Estimates for almost minimizers

Lemma 34. *1. Let $x \in \mathbb{R}^2$, $0 < r < R$, $\alpha \in L^\infty(\mathbb{R}^2, [b^2, 1])$, $C_0 > 0$ and a map $w \in H^1(\mathcal{R}(x, R, r), \mathbb{S}^1)$ s.t. $\deg_{\partial B(x, R)}(w) = 1$ and*

$$\frac{1}{2} \int_{\mathcal{R}(x, R, r)} \alpha |\nabla w|^2 - \mu_\alpha(\mathcal{R}(x, R, r), 1) \leq C_0.$$

Then for all r', R' s.t. $r < r' < R' < R$ one has

$$\frac{1}{2} \int_{\mathcal{R}(x, R', r')} \alpha |\nabla w|^2 - \mu_\alpha(\mathcal{R}(x, R', r'), 1) \leq 4C_b + C_0,$$

where C_b depends only on b and is given by Proposition 29.

2. Let $x_1, \dots, x_d \in \Omega$, $d_i = 1$, $\varepsilon < \rho < 10^{-2}\eta$, $\eta := 10^{-2} \cdot \min\{|x_i - x_j|, \text{dist}(x_i, \partial\Omega)\}$, $C_0 > 0$ and $w \in H^1(\Omega'_\rho, \mathbb{S}^1)$ s.t.

$$\frac{1}{2} \int_{\Omega'_\rho} U_\varepsilon^2 |\nabla w|^2 \leq I_{\rho, \varepsilon} + C_0.$$

Then for $\rho \leq r < R < \eta$ one has for all i

$$\frac{1}{2} \int_{\mathcal{R}(x_i, R, r)} U_\varepsilon^2 |\nabla w|^2 - \mu_\varepsilon(\mathcal{R}(x_i, R, r), 1) \leq C_0 + C(\eta);$$

here $C(\eta)$ depends only on b, g, Ω, Ω' and η .

3. Under the hypotheses of 2., we also have for $\eta > \rho_0 > \rho$

$$\frac{1}{2} \int_{\Omega'_{\rho_0}} U_\varepsilon^2 |\nabla w|^2 \leq C(\rho_0, C_0);$$

here $C(\eta, C_0)$ depends only on $b, g, \Omega, \Omega', C_0, \rho_0$ and η .

Proof. Using the third part of Proposition 30, we have

$$\begin{aligned} \frac{1}{2} \int_{\mathcal{R}(x,R,r)} \alpha |\nabla w|^2 &\leq \mu_\alpha(\mathcal{R}(x, R, R'), 1) + \mu_\alpha(\mathcal{R}(x, R', r'), 1) \\ &\quad + \mu_\alpha(\mathcal{R}(x, r', r), 1) + 4C_b + C_0. \end{aligned}$$

We easily obtain

$$\frac{1}{2} \int_{\mathcal{R}(x,R,r)} \alpha |\nabla w|^2 \geq \mu_\alpha(\mathcal{R}(x, R, R'), 1) + \frac{1}{2} \int_{\mathcal{R}(x,R',r')} \alpha |\nabla w|^2 + \mu_\alpha(\mathcal{R}(x, r', r), 1)$$

which proves the first assertion.

The second assertion is obtained by using the same argument combined with Proposition 33.

Last assertion is a straightforward consequence of Proposition 33 and both previous assertions. \square

D.2.2 Lower bound on circles

In this subsection we prove an estimate for the minimization of weighted 1-dimensional Dirichlet functionals.

Lemma 35. *Let $\theta_0 \in (0, 2\pi)$ and let $\alpha : [0, 2\pi] \rightarrow \{b^2, 1\}$ s.t. $\alpha(\theta) = \begin{cases} b^2 & \text{if } \theta \in [0, \theta_0) \\ 1 & \text{if } \theta \in [\theta_0, 2\pi] \end{cases}$.*

Let $\varphi \in H^1([0, 2\pi], \mathbb{R})$ s.t. $\varphi(2\pi) - \varphi(0) = 2\pi$. The following lower bound holds

$$\frac{1}{2} \int_0^{2\pi} \alpha(\theta) |\partial_\theta \varphi(\theta)|^2 d\theta \geq \frac{2\pi^2}{\int_0^{2\pi} \frac{1}{\alpha}} = \frac{2\pi^2}{2\pi + \theta_0(b^{-2} - 1)}.$$

Proof. The proof of these lower bounds is based on computations of minimal energies.

We prove the first estimate. It is easy to check that a minimal function $\varphi_{\min} \in H^1([0, 2\pi], \mathbb{R})$ for $\frac{1}{2} \int_0^{2\pi} \alpha(\theta) |\partial_\theta \cdot|^2 d\theta$ under the constraint $\varphi(2\pi) - \varphi(0) = 2\pi$ exists and satisfies $\partial_\theta(\alpha \partial_\theta \varphi_{\min}) = 0$. Thus $\partial_\theta \varphi_{\min} = \frac{\text{Cst}}{\alpha}$ with $\text{Cst} = \frac{2\pi}{\int_0^{2\pi} \alpha^{-1}}$. Therefore

$$\frac{1}{2} \int_0^{2\pi} \alpha(\theta) |\partial_\theta \varphi(\theta)|^2 d\theta \geq \frac{1}{2} \int_0^{2\pi} \alpha(\theta) |\partial_\theta \varphi_{\min}(\theta)|^2 d\theta = \frac{2\pi^2}{\int_0^{2\pi} \frac{1}{\alpha}} = \frac{2\pi^2}{2\pi + \theta_0(b^{-2} - 1)}.$$

\square

D.3 Proof of the first part of Proposition 5

Let $x_1^n, \dots, x_N^n \in \Omega$ s.t. $|x_i^n - x_j^n| \geq 8\rho$ and $d_1, \dots, d_N > 0, \sum d_i = d$ (up to a subsequence the degrees may be considered independent of n).

Assume that

$$\text{there is } i_0 \in \{1, \dots, N\} \text{ s.t. } d_{i_0} \neq 1 \text{ or that there are } i \neq j \text{ s.t. } |x_i^n - x_j^n| \rightarrow 0. \quad (\text{D.4})$$

Up to a subsequence, there are $a_1, \dots, a_M \in \overline{\Omega}$ and $\{\Lambda_1, \dots, \Lambda_M\}$ a partition of $\{1, \dots, N\}$ s.t.

$$i \in \Lambda_l \iff x_i^n \rightarrow a_l.$$

Note that since $d_i > 0$, (D.4) is equivalent to

$$\text{there exists } l_0 \in \{1, \dots, M\} \text{ s.t. } \tilde{d}_{l_0} = \sum_{i \in \Lambda_{l_0}} d_i > 1.$$

There are two cases:

1. $\text{Card}(\Lambda_l) > 1$,
2. $\text{Card}(\Lambda_l) = 1$.

In the first case, we apply the separation process (defined in Section C.1) in $\Omega_l^n = B(a_l, 2\rho_0) \setminus \cup_{i \in \Lambda_l} \overline{B(x_i, \rho)}$.

Since for $i, j \in \Lambda_l$ we have $|x_i - x_j| \ll \eta_{\text{stop}}$, in the end of the process (after K steps), we obtain a unique $x_1^K = y_l \in \{x_i \mid i \in \Lambda_l\}$ in the final selection of points and $\eta_K \rightarrow 0$.

For $k \in \{1, \dots, K\}$ we denote $\{x_1^k, \dots, x_{N_k}^k\}$ the selection of points made in Step k , η_k the radius of the final balls in Step k and η'_k the radius of the intermediate balls. Note that $\eta_0 = \rho$.

From (C.3) and (C.4), the following rings are mutually disjoint

$$R_{j,k} = \mathcal{R}(x_j^k, \eta'_{k+1}, \eta_k), \tilde{d}_{j,k} = \sum_{x_i \in B(x_j^k, \eta'_{k+1})} d_i \text{ with } k \in \{0, \dots, K-1\}, j \in \{1, \dots, N_k\},$$

$$R_0^l = \mathcal{R}(y_l, \rho_0, \eta_K).$$

For $w \in H_g^1(\Omega'_\rho, \mathbb{S}^1)$ we have

$$\begin{aligned} \frac{1}{2} \int_{\Omega_l^n} U_{\varepsilon_n}^2 |\nabla w|^2 &\geq \frac{1}{2} \int_{R_0^l} U_{\varepsilon_n}^2 |\nabla w|^2 + \sum_{k=0}^{K-1} \sum_{j=1}^{N_k} \frac{1}{2} \int_{R_{j,k}} U_{\varepsilon_n}^2 |\nabla w|^2 \\ &\geq \frac{1}{2} \int_{R_0^l} U_{\varepsilon_n}^2 |\nabla w|^2 + \sum_{k=0}^{K-1} \sum_{j=1}^{N_k} \mu_{\varepsilon_n}(\mathcal{R}(x_j^k, \eta'_{k+1}, \eta_k), \tilde{d}_{j,k}) \\ &\geq \tilde{d}_l^2 \mu_{\varepsilon_n}(\mathcal{R}(x_0, \rho_0, \eta_K), 1) + \sum_{k=0}^{K-1} \sum_{j=1}^{N_k} \tilde{d}_{j,k} \mu_{\varepsilon_n}(\mathcal{R}(x_0, \eta_{k+1}, \eta_k), 1) - \mathcal{O}(1) \\ &\geq \tilde{d}_l \mu_{\varepsilon_n}(\mathcal{R}(x_0, \rho_0, \rho), 1) + (\tilde{d}_l^2 - \tilde{d}_l) \pi b^2 |\ln \eta_K| - \mathcal{O}(1). \end{aligned} \quad (\text{D.5})$$

In the second case the computations are direct

$$\begin{aligned} \frac{1}{2} \int_{\Omega_l^n} U_{\varepsilon_n}^2 |\nabla w|^2 &\geq \frac{1}{2} \int_{\mathcal{R}(x_l, \rho_0, \rho)} U_{\varepsilon_n}^2 |\nabla w|^2 \\ &\geq \tilde{d}_l \mu_{\varepsilon_n}(\mathcal{R}(x_0, \rho_0, \rho), 1) + (\tilde{d}_l^2 - \tilde{d}_l) \pi b^2 |\ln \rho| - \mathcal{O}(1). \end{aligned} \quad (\text{D.6})$$

Summing the lower bounds (D.5) and (D.6) over l and applying Proposition 33, we obtain the result since $\eta \rightarrow 0$, $\eta \in \{\eta_K, \rho\}$ and $\tilde{d}_{l_0} > 1$.

D.4 Proof of the second part of Proposition 5

We now prove the second part of Proposition 5: we establish the repelling effect of $\partial\Omega$ on the centers x_i 's.

Let $x_1^n, \dots, x_d^n \in \Omega$ and $\rho = \rho(\varepsilon_n) \downarrow 0$ s.t. $\text{dist}(x_1^n, \partial\Omega) \rightarrow 0$. From the previous subsection we may assume that there is $\eta_0 > 0$ (independent of n) s.t.

$$\min \left\{ \min_{i \neq j} |x_i^n - x_j^n|, \text{dist}(\Omega, \partial\Omega') \right\} \geq 10^2 \eta_0.$$

Up to a subsequence we may assume that $x_i^n \rightarrow a_i \in \overline{\Omega}$ with $a_i \neq a_j$ for $i \neq j$. Let $\eta = \sqrt{|x_1^n - a_1|}$

We fix $x_0 = x_0(\varepsilon_n) \in \Omega$ s.t.

$$\mu_\varepsilon(\mathcal{R}(x_0, \eta_0, \rho), 1) \leq \inf_{x \in \mathbb{R}^2} \mu_\varepsilon(\mathcal{R}(x, \eta_0, \rho), 1) + 1.$$

We prove that for $w \in H_g^1(\Omega' \setminus \cup_i \overline{B(x_i^n, \rho)}, \mathbb{S}^1)$ we have

$$\frac{1}{2} \int_{\mathcal{R}(a_i, \sqrt{\eta}, \eta/2)} U_\varepsilon^2 |\nabla w|^2 \gg \mu_\varepsilon(\mathcal{R}(x_0, \sqrt{\eta}, \eta/2), 1). \quad (\text{D.7})$$

Estimate (D.7) implies that $\{x_1^n, \dots, x_d^n\}$ can not be an almost minimizing configuration of points.

Indeed, $\mathcal{R}(a_i, \sqrt{\eta}, \eta/2) \supset \mathcal{R}(x_i^n, \sqrt{\eta}/2, 2\eta)$ and by Lemma (28), $\mu_\varepsilon(\mathcal{R}(a_i, \sqrt{\eta}, \eta/2), 1) = \mu_\varepsilon(\mathcal{R}(x_i^n, \sqrt{\eta}/2, 2\eta), 1) + \mathcal{O}(1)$. Thus combining (D.7) with the third assertion of Proposition 30, we obtained that $\mu_\varepsilon(\mathcal{R}(x_1^n, \eta_0, \rho), 1) \gg \mu_\varepsilon(\mathcal{R}(x_0, \eta_0, \rho), 1)$. And since for $j \in \{2, \dots, d\}$ we have $\mu_\varepsilon(\mathcal{R}(x_j^n, \eta_0, \rho), 1) \geq \mu_\varepsilon(\mathcal{R}(x_0, \eta_0, \rho), 1) + \mathcal{O}(1)$, by Proposition 33, we get the result.

We argue by contradiction and we assume that there is $w_* = w_*^\varepsilon \in H_g^1(\Omega' \setminus \cup_i \overline{B(x_i^n, \rho)}, \mathbb{S}^1)$ s.t.

$$\frac{1}{2} \int_{\mathcal{R}(a_i, \sqrt{\eta}, \eta/2)} U_\varepsilon^2 |\nabla w_*|^2 = \mu_\varepsilon(\mathcal{R}(x_0, \sqrt{\eta}, \eta/2), 1) + \mathcal{O}(1). \quad (\text{D.8})$$

In particular we have $\frac{1}{2} \int_{\mathcal{R}(a_i, \sqrt{\eta}, \eta/2)} U_\varepsilon^2 |\nabla w_*|^2 = \mu_\varepsilon(\mathcal{R}(a_1, \sqrt{\eta}, \eta/2), 1) + \mathcal{O}(1)$.

The key ingredient to get a contradiction is the fact that the map w_* is almost constant in the "half" ring $\mathcal{R}(a_i, \sqrt{\eta}, \eta/2) \setminus \Omega$.

By smoothness of Ω , we may assume that the cone $K_{\sqrt{\eta}, \eta/2} := \{x = a_1 + \rho e^{i\theta} \mid \theta \in [0, \pi/2], \eta/2 \leq \rho \leq \sqrt{\eta}\}$ does not intersect Ω : $K_{\sqrt{\eta}, \eta/2} \cap \Omega = \emptyset$.

We consider the map $w_0(a_1 + \rho e^{i\theta}) = \begin{cases} e^{i4\theta} & \text{if } \theta \in [0, \pi/2] \\ 1 & \text{otherwise} \end{cases}$ which is s.t. $w_0 \in H^1(\mathcal{R}(a_1, \sqrt{\eta}, \eta/2), \mathbb{S}^1)$

and $\text{deg}_{\partial B(a_1, \sqrt{\eta})}(w_0) = 1$.

For $\tilde{d} \in \mathbb{N}^*$ (to be fix later) we define the map $w_{\text{test}} = w_*^{\tilde{d}} w_0 \in H^1(\mathcal{R}(a_1, \sqrt{\eta}, \eta/2), \mathbb{S}^1)$ and $\text{deg}_{\partial B(a_1, \sqrt{\eta})}(w_{\text{test}}) = \tilde{d} + 1$.

Thus, we have

$$\frac{1}{2} \int_{\mathcal{R}(a_1, \sqrt{\eta}, \eta/2)} U_\varepsilon^2 |\nabla w_{\text{test}}|^2 \geq \mu_\varepsilon(\mathcal{R}(a_1, \sqrt{\eta}, \eta/2), \tilde{d} + 1) = (\tilde{d} + 1)^2 \mu_\varepsilon(\mathcal{R}(a_1, \sqrt{\eta}, \eta/2), 1).$$

On the other hand, letting $\varphi_*, \varphi_0 : \mathcal{R}(a_1, \sqrt{\eta}, \eta/2) \rightarrow \mathbb{R}$ s.t. $w_* = e^{i\varphi_*(\theta)}$ and $w_0 = e^{i\varphi_0(\theta)}$, (note that φ_*, φ_0 are locally defined and those gradients are globally defined and lie in $L^2(\mathcal{R}(a_1, \sqrt{\eta}, \eta/2), \mathbb{R})$) we have (using (D.8)),

$$\begin{aligned} \frac{1}{2} \int_{\mathcal{R}(a_1, \sqrt{\eta}, \eta/2)} U_\varepsilon^2 |\nabla w_{\text{test}}|^2 &= \frac{1}{2} \int_{\mathcal{R}(a_1, \sqrt{\eta}, \eta/2)} U_\varepsilon^2 |\tilde{d} \nabla \varphi_* + \nabla \varphi_0|^2 \\ &= \frac{\tilde{d}^2}{2} \int_{\mathcal{R}(a_1, \sqrt{\eta}, \eta/2)} U_\varepsilon^2 |\nabla \varphi_*|^2 + \frac{1}{2} \int_{\mathcal{R}(a_1, \sqrt{\eta}, \eta/2)} U_\varepsilon^2 |\nabla \varphi_0|^2 + \\ &\quad + \tilde{d} \int_{\mathcal{R}(a_1, \sqrt{\eta}, \eta/2)} U_\varepsilon^2 \nabla \varphi_* \cdot \nabla \varphi_0 \\ &\leq \tilde{d}^2 \mu_\varepsilon(\mathcal{R}(a_1, \sqrt{\eta}, \eta/2), 1) + 4\pi |\ln \eta| + \\ &\quad + \tilde{d} \int_{\mathcal{R}(a_1, \sqrt{\eta}, \eta/2)} U_\varepsilon^2 \nabla \varphi_* \cdot \nabla \varphi_0 + \mathcal{O}(1). \end{aligned}$$

Since $w_* = g$ in $\mathcal{R}(a_1, \sqrt{\eta}, \eta/2) \setminus \Omega$ and $\|\nabla \varphi_0\|_{L^2(\mathcal{R}(a_1, \sqrt{\eta}, \eta/2) \cap \Omega)} = 0$, we have (using Cauchy-Schwarz inequality)

$$\left| \int_{\mathcal{R}(a_1, \sqrt{\eta}, \eta/2)} U_\varepsilon^2 \nabla \varphi_* \cdot \nabla \varphi_0 \right| = \mathcal{O}(\sqrt{|\ln \eta|}).$$

Therefore we obtain

$$\tilde{d}^2 \mu_\varepsilon(\mathcal{R}(a_1, \sqrt{\eta}, \eta/2), 1) + 4\pi |\ln \eta| + \mathcal{O}(\sqrt{|\ln \eta|}) \geq (\tilde{d} + 1)^2 \mu_\varepsilon(\mathcal{R}(a_1, \sqrt{\eta}, \eta/2), 1)$$

which implies that $4\pi |\ln \eta| + \mathcal{O}(\sqrt{|\ln \eta|}) \geq (2\tilde{d} + 1) \mu_\varepsilon(\mathcal{R}(a_1, \sqrt{\eta}, \eta/2), 1) \geq (2\tilde{d} + 1) b^2 \pi |\ln \eta|$. Clearly we obtain a contradiction taking $\tilde{d} > (4 - b^2)/(2b^2)$.

D.5 Proof of the third part of Proposition 5

In this subsection, we prove the third part of Proposition 5: the attractive effect of the inclusions.

Assume that there exist $C_0 > 0$, sequences $\varepsilon_n, \rho \downarrow 0$, $\rho = \rho(\varepsilon_n) \geq \varepsilon_n$ s.t. $\rho/(\lambda\delta) \rightarrow 0$ and distinct points x_1^n, \dots, x_d^n , satisfying

$$\inf_{\substack{w \in H_g^1(\Omega'_\rho, \mathbb{S}^1) \\ \deg_{\partial B(x_i, \rho)}(w) = 1}} \frac{1}{2} \int_{\Omega'_\rho} U_{\varepsilon_n}^2 |\nabla w|^2 - I_{\rho, \varepsilon_n} \leq C_0. \quad (\text{D.9})$$

We denote $\mathbf{x}_n = (x_1^n, \dots, x_d^n)$.

From the first and the second assertion, there exists $\eta_0 > 0$ (independent of ε) s.t.

$$\min \left\{ \min_{i \neq j} |x_i^n - x_j^n|, \min_i \text{dist}(x_i^n, \partial\Omega) \right\} \geq 10^2 \cdot \eta_0 > 0.$$

We want to prove that there is some $c > 0$ s.t. for $i = 1, \dots, d$ we have (for small ε) $B(x_i^n, c\lambda\delta) \subset \omega_\varepsilon$.

To this end, we argue by contradiction and we assume that either $x_1^n \notin \omega_\varepsilon$ or $x_1^n \in \omega_\varepsilon$ and $\frac{\text{dist}(x_1^n, \partial\omega_\varepsilon)}{\lambda\delta} \rightarrow 0$.

We are going to prove that letting $y_n \in \delta \cdot (\mathbb{Z} \times \mathbb{Z})$ s.t. $x_1^n, y_n \in \overline{Y_{k,l}^\delta}$, then,

$$\widehat{\mathcal{I}}_{\rho,\varepsilon_n}(\mathbf{x}_n, \mathbf{1}) - \widehat{\mathcal{I}}_{\rho,\varepsilon_n}((y_n, x_2^n, \dots, x_d^n), \mathbf{1}) \rightarrow \infty. \quad (\text{D.10})$$

Up to a subsequence, we may assume that $\lim_n \frac{\text{dist}(x_1^n, \omega_\varepsilon)}{\lambda\delta}$ exists. We divide the proof into two steps:

Step 1. if $x_1^n \notin \omega_\varepsilon$ and $\frac{\text{dist}(x_1^n, \omega_\varepsilon)}{\lambda\delta} \rightarrow c \in (0, \infty]$, then (D.10) holds;

Step 2. if $\frac{\text{dist}(x_1^n, \omega_\varepsilon)}{\lambda\delta} \rightarrow 0$, then (D.10) holds.

We now prove Step 1.

Assume that there exist $C_0 > 0$, sequences $\varepsilon_n, \rho \downarrow 0$, $\rho = \rho(\varepsilon_n) \geq \varepsilon_n$ and distinct points x_1^n, \dots, x_d^n (well separated and far from $\partial\Omega$) s.t. $\rho/(\lambda\delta) \rightarrow 0$, $x_1^n \notin \omega_\varepsilon$, $\frac{\text{dist}(x_1^n, \omega_\varepsilon)}{\lambda\delta} \rightarrow c \in (0, \infty]$ and

$$\inf_{\substack{w \in H_g^1(\Omega'_\rho, \mathbb{S}^1) \\ \text{deg}_{\partial B(x_i, \rho)}(w)=1}} \frac{1}{2} \int_{\Omega'_\rho} U_{\varepsilon_n}^2 |\nabla w|^2 - I_{\rho, \varepsilon_n} \leq C_0.$$

Denote w_n a minimizer for $\widehat{\mathcal{I}}_{\rho, \varepsilon_n}(\mathbf{x}_n, \mathbf{1})$ (see Proposition 2). Using Lemma 34 Part 2, for $\rho \leq r < R < \eta_0$, one has

$$\int_{B(x_1^n, R) \setminus \overline{B(x_1^n, r)}} U_{\varepsilon_n}^2 |\nabla w_n|^2 - \mu_{\varepsilon_n}(B(x_1^n, R) \setminus \overline{B(x_1^n, r)}, 1) \leq C_0 + C(\eta_0).$$

Let $\kappa \in (0, 10^{-2} \cdot c)$ be s.t. $B(0, 2\kappa) \subset \omega \subset Y$ and $\text{dist}(\omega, \partial Y) \geq 10\kappa$.

From Lemma 34.3, we have

$$\widehat{\mathcal{I}}_{\rho, \varepsilon_n}(\mathbf{x}_n, \mathbf{1}) = \sum_{i=1}^d \mu_{\varepsilon_n}(\mathcal{R}(x_i^n, \eta_0, \rho), 1) + \mathcal{O}(1)$$

and

$$\widehat{\mathcal{I}}_{\rho, \varepsilon_n}((y_n, x_2^n, \dots, x_d^n), \mathbf{1}) = \mu_{\varepsilon_n}(\mathcal{R}(y_n, \eta_0, \rho), 1) + \sum_{i=2}^d \mu_{\varepsilon_n}(\mathcal{R}(x_i^n, \eta_0, \rho), 1) + \mathcal{O}(1).$$

Since $|x_1^n - y_n| \leq \delta$, using Propositions 29, 30.3 and Lemma 28, we have

$$\mu_{\varepsilon_n}(\mathcal{R}(y_n, \eta_0, \rho), 1) = \mu_{\varepsilon_n}(\mathcal{R}(x_1^n, \eta_0, \delta), 1) + \mu_{\varepsilon_n}(\mathcal{R}(y_n, \kappa\delta, \rho), 1) + \mathcal{O}(1)$$

Therefore

$$\widehat{\mathcal{I}}_{\rho, \varepsilon_n}(\mathbf{x}_n, \mathbf{1}) - \widehat{\mathcal{I}}_{\rho, \varepsilon_n}((y_n, x_2^n, \dots, x_d^n), \mathbf{1}) = \mu_{\varepsilon_n}(\mathcal{R}(x_1^n, \kappa\delta, \rho), 1) - \mu_{\varepsilon_n}(\mathcal{R}(y_n, \kappa\delta, \rho), 1). \quad (\text{D.11})$$

Thus it suffices to estimate the energies in the rings with radii $\kappa\delta$ and ρ . We have (using (1.5))

$$\mu_{\varepsilon_n}(\mathcal{R}(y_n, \kappa\delta, \rho), 1) = \pi |\ln \lambda| + b^2 \pi \ln \frac{\rho}{\lambda\delta} + \mathcal{O}(1). \quad (\text{D.12})$$

In order to estimate $\mu_{\varepsilon_n}(\mathcal{R}(x_1^n, \kappa\delta, \rho), 1)$, we let $\chi = \begin{cases} \frac{c}{2}\lambda\delta & \text{if } c < \infty \\ \lambda\delta & \text{otherwise} \end{cases}$ and $\eta = \text{dist}(x_1^n, \partial\omega_\varepsilon)$.

Note that $\frac{\eta + \chi}{\eta - \chi} = \mathcal{O}(1)$ and that $U_{\varepsilon_n} = 1 + V_n$ in $\mathcal{R}(x_1^n, \kappa\delta, \eta + \chi) \cup \mathcal{R}(x_1^n, \eta - \chi, \rho)$, $\|V_n\|_{L^\infty} = o(\varepsilon_n^2)$ (from (1.5)).

Thus we obtain

$$\begin{aligned} \mu_{\varepsilon_n}(\mathcal{R}(x_1^n, \kappa\delta, \rho), 1) &\geq \pi \ln \frac{\delta}{\eta + \chi} + \pi b^2 \ln \frac{\eta + \chi}{\eta - \chi} + \pi \ln \frac{\eta - \chi}{\rho} + \mathcal{O}(1) \\ &= \pi \ln \frac{\delta}{\rho} + \mathcal{O}(1). \end{aligned} \quad (\text{D.13})$$

Estimates (D.11), (D.12) and (D.13) contradict (D.9).

We now turn to Step 2. Arguing as in Step 1., it suffices to prove that

$$\mu_{\varepsilon_n}(\mathcal{R}(x_1^n, \kappa\delta, \rho), 1) - \mu_{\varepsilon_n}(\mathcal{R}(y_n, \kappa\delta, \rho), 1) \rightarrow \infty \text{ for some fixed } \kappa. \quad (\text{D.14})$$

It is direct to check that

$$\mu_{\varepsilon_n}(\mathcal{R}(y_n, \kappa\delta, \rho), 1) = \pi |\ln \lambda| + b^2 \ln \frac{\lambda\delta}{\rho} + \mathcal{O}(1). \quad (\text{D.15})$$

Let $\kappa > 0$ depending only on ω be s.t.

$$\kappa < 10^{-2} \cdot \text{dist}(\omega, \partial Y) \text{ and } B(0, 10^2 \cdot \kappa) \subset \omega.$$

Let $r_n = \max \left\{ \varepsilon_n^{1/4}, \rho, \sqrt{\lambda\delta \cdot \text{dist}(x_n, \partial\omega_\varepsilon)} \right\} + \sqrt{\varepsilon_n}$. We consider K_n the cone of vertex x_n and aperture $\pi/2$ which admits the line $(x_n, \Pi_{\partial\omega_\varepsilon} x_n)$ for symmetry axis and s.t. $K_n \cap \omega_\varepsilon \cap \mathcal{R}(x_1^n, \kappa\lambda\delta, r_n) = \emptyset$. Here $\Pi_{\partial\omega_\varepsilon}(x_n)$ is the orthogonal projection of x_n on $\partial\omega_\varepsilon$.

Note that since $\frac{\text{dist}(x_n, \omega_\varepsilon)}{\lambda\delta} \rightarrow 0$, for large n and small κ (independently of n), by smoothness of ω , K_n is well defined (see Figure 5).

We have $U_{\varepsilon_n} = 1 + V_n$ in $\mathcal{R}(x_1^n, \kappa\lambda\delta, r_n) \cap K_n$ where, $\|V_n\|_{L^\infty} = o(\varepsilon_n^2)$. Thus, if we define $\alpha_n = \begin{cases} 1 & \text{in } K_n \\ b^2 & \text{otherwise} \end{cases}$, then, from Lemma 35 with $\theta_0 = 3\pi/2$, for $w \in H^1(\mathcal{R}(x_1^n, \kappa\lambda\delta, r_n), \mathbb{S}^1)$ s.t. $\text{deg}_{\partial B(x_1^n, r_n)}(w) = 1$, we have

$$\frac{1}{2} \int_{\mathcal{R}(x_1^n, \kappa\lambda\delta, r_n)} \alpha_n |\nabla w|^2 \geq b^2 \frac{4\pi}{b^2 + 3} \ln \frac{\kappa\lambda\delta}{r_n}.$$

Clearly, from construction, $U_{\varepsilon_n}^2 \geq \alpha_n + o(\varepsilon_n^2)$, thus if w_n is a minimizing map for $\widehat{\mathcal{I}}_{\rho, \varepsilon_n}(\mathbf{x}_n, \mathbf{1})$, then we have

$$\frac{1}{2} \int_{\mathcal{R}(x_1^n, \kappa\lambda\delta, r_n)} U_{\varepsilon_n} |\nabla w_n|^2 \geq b^2 \frac{4\pi}{b^2 + 3} \ln \frac{\kappa\lambda\delta}{r_n} + o_n(1).$$

Now the computations are direct

$$\begin{aligned} \mu_{\varepsilon_n}(\mathcal{R}(x_1^n, \kappa\delta, \rho), 1) &= \mu_{\varepsilon_n}(\mathcal{R}(x_1^n, \kappa\delta, 3\lambda\delta), 1) + \mu_{\varepsilon_n}(\mathcal{R}(x_1^n, \kappa\lambda\delta, r_n), 1) + \mu_{\varepsilon_n}(\mathcal{R}(x_1^n, r_n, \rho), 1) + \mathcal{O}(1) \\ &\geq \pi |\ln \lambda| + b^2 \frac{4\pi}{b^2 + 3} \ln \frac{\lambda\delta}{r_n} + b^2 \ln \frac{r_n}{\rho} + \mathcal{O}(1). \end{aligned} \quad (\text{D.16})$$

Therefore, (D.14) is a direct consequence of (D.15) and (D.16) since $\frac{\lambda\delta}{r_n} \rightarrow +\infty$.

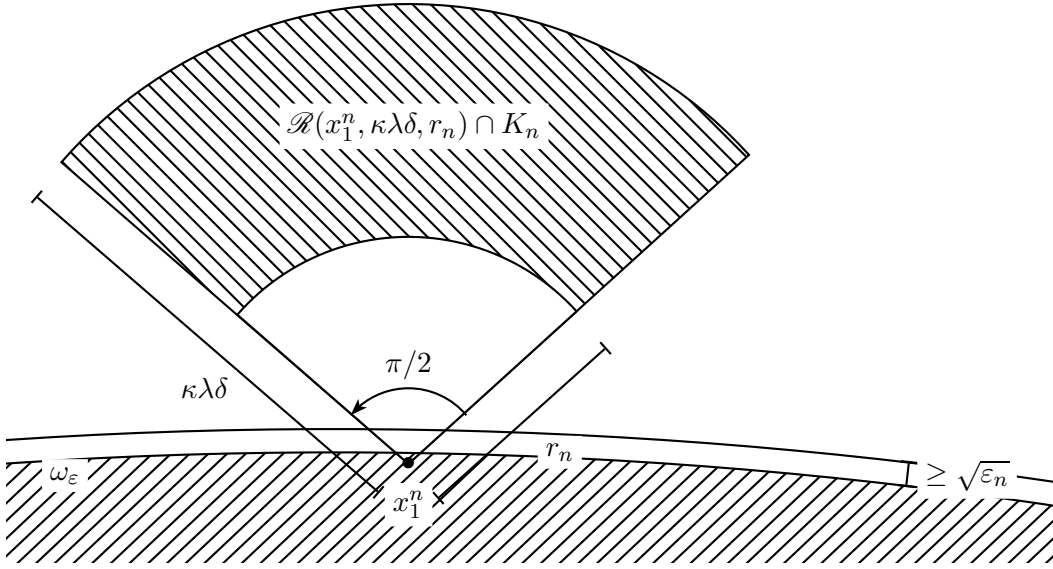

Figure 5: The domain $W_n \cap K_n$

E Proof of Propositions 8 and 9

E.1 An important effect of the dilution of inclusions

We first state a result which establishes that a sufficiently large circle has a small intersection with ω_ε if $\lambda \rightarrow 0$.

Lemma 36. *For $\rho \geq \delta$, if C_ρ is a circle with radius ρ , then $\mathcal{H}^1(C_\rho \cap \omega_\varepsilon) \leq 16\pi^2 \lambda \rho$.*

Proof. Let $S := \begin{cases} \{\tilde{Y}_\varepsilon \mid \tilde{Y}_\varepsilon \text{ is a } \delta \times \delta\text{-periodic cell s.t. } \tilde{Y}_\varepsilon \cap C_\rho \neq \emptyset\} & \text{in the periodic case} \\ \{\tilde{Y}_\varepsilon = B(y_{i,j}^\varepsilon, \lambda\delta^j) \mid y_{i,j}^\varepsilon \in M_j^\varepsilon \text{ and } \tilde{Y}_\varepsilon \cap C_\rho \neq \emptyset\} & \text{in the non-periodic case} \end{cases}$.

For $\tilde{Y}_\varepsilon \in S$, we denote $\tilde{\omega}_\varepsilon$ the connected component of ω_ε which is included in \tilde{Y}_ε .

For simplicity, we fix $j = 1$ if we are in the periodic case (and $j \in \{1, \dots, P \mid M_j^\varepsilon \in \mathbb{N}^*\}$ if we are in the non-periodic case).

Since $\rho \geq \delta$, if $\tilde{Y}_\varepsilon \in S$, then $C_\rho \not\subseteq \tilde{Y}_\varepsilon$. We have easily for $\tilde{Y}_\varepsilon \in S$

$$\mathcal{H}^1(C_\rho \cap \tilde{\omega}_\varepsilon) \leq 2\pi\lambda\delta^j$$

and

$$\mathcal{H}^1(C_\rho \cap \tilde{Y}_\varepsilon \setminus \tilde{\omega}_\varepsilon) \geq \delta^j \cdot \left(\frac{1}{2} - 2\pi\lambda \right).$$

Thus we obtain

$$\mathcal{H}^1(C_\rho \cap \tilde{\omega}_\varepsilon) \leq 2\pi\lambda \frac{\mathcal{H}^1(C_\rho \cap \tilde{Y}_\varepsilon \setminus \tilde{\omega}_\varepsilon)}{\frac{1}{2} - 2\pi\lambda} \leq 8\pi\lambda \mathcal{H}^1(C_\rho \cap \tilde{Y}_\varepsilon \setminus \tilde{\omega}_\varepsilon).$$

Consequently,

$$\mathcal{H}^1(C_\rho \cap \omega_\varepsilon) = \sum_{\tilde{Y}_\varepsilon \in S} \mathcal{H}^1(C_\rho \cap \tilde{\omega}_\varepsilon) \leq 8\pi\lambda \sum_{\tilde{Y}_\varepsilon \in S} \mathcal{H}^1(C_\rho \cap \tilde{Y}_\varepsilon \setminus \tilde{\omega}_\varepsilon) \leq 8\pi\lambda \mathcal{H}^1(C_\rho) = 16\pi^2 \lambda \rho.$$

□

E.2 Proof of Proposition 8

We are now in position to prove Proposition 8. The proof is done in 3 steps.

Let \mathbf{x}_n be a quasi-minimizer for $J_{\rho, \varepsilon}$, $\rho = \rho(\varepsilon_n) \downarrow 0$, $\rho \geq \varepsilon_n$. From Corollary 6, up to a subsequence, there are $\eta_0 > 0$ and $\mathbf{a} = (a_1, \dots, a_d) \in \Omega^d$ independent of ε_n s.t. $x_i^n \rightarrow a_i$, $|a_i - a_j|, \text{dist}(a_i, \partial\Omega) > 10^2\eta_0$.

We prove that $W_g(a_1, \dots, a_d) = \min_{b_1, \dots, b_n \in \Omega} W_g(b_1, \dots, b_n)$. We argue by contradiction and we assume that, up to consider a smaller value for η_0 if necessary, we have the existence of $\mathbf{b} = (b_1, \dots, b_d) \in \Omega^d$ s.t. $|b_i - b_j| \geq 10^2\eta_0$, $\text{dist}(b_i, \partial\Omega) > 10^2\eta_0$ and

$$W_g(\mathbf{b}) < W_g(\mathbf{a}) + 10^2\eta_0.$$

Step 1. We estimate the energies in perforated domains with a fixed (small) perforation size. The goal of this step is to prove the existence of small ρ_0 (independent of ε_n) s.t. we

have for $\mathbf{c} \in \{\mathbf{a}, \mathbf{b}\}$ and $\mathbf{x} \in \Omega^d$ s.t. $\max_i |x_i - c_i| \leq \rho_0$

$$\hat{\mathcal{J}}_{\rho_0, \mathbb{I}}(\mathbf{x}) - \hat{\mathcal{J}}_{\rho_0, \varepsilon_n}(\mathbf{x}) \leq 2\eta_0 \quad (\text{E.1})$$

From [10] ((15) and Lemma 2), we may fix $\rho_0 > 0$ independent of ε_n s.t. for $\mathbf{c} \in \{\mathbf{a}, \mathbf{b}\}$, we have

$$\hat{\mathcal{J}}_{\rho_0, \mathbb{I}}(\mathbf{x}) - \hat{\mathcal{I}}_{\rho_0, \mathbb{I}}(\mathbf{x}) \leq \eta_0 \text{ for all } \mathbf{x} \in \Omega^d \text{ s.t. } \max_i |x_i - c_i| \leq \rho_0,$$

$$\left| \hat{\mathcal{I}}_{\rho_0, \mathbb{I}}(\mathbf{x}) - \pi d |\ln \rho_0| - W_g(\mathbf{x}) \right| \leq \eta_0 \text{ for all } \mathbf{x} \in \Omega^d \text{ s.t. } \max_i |x_i - c_i| \leq \rho_0$$

and

$$|W_g(\mathbf{c}) - W_g(\mathbf{x})| \leq \eta_0 \text{ for all } \mathbf{x} \in \Omega^d \text{ s.t. } \max_i |x_i - c_i| \leq \rho_0$$

For $\mathbf{c} \in \{\mathbf{a}, \mathbf{b}\}$ and $\mathbf{x} \in \Omega^d$ s.t. $\max_i |x_i - c_i| \leq \rho_0$:

- We let $\theta_{\mathbf{x}} = \sum_{i=1}^d \theta_{x_i}$ where $\theta_{x_i} \in (-\pi, \pi]$, $\frac{x - x_i}{|x - x_i|} = e^{i\theta_{x_i}}$ ($x \neq x_i$) is main determination of the argument of $x - x_i$.
- We fix $\phi_0^{\mathbf{x}} \in C^\infty(\partial\Omega, \mathbb{R})$ s.t. $e^{i\phi_0^{\mathbf{x}}} = ge^{-i\theta_{\mathbf{x}}}$. Clearly, since $\deg_{\partial\Omega}(ge^{-i\theta_{\mathbf{x}}}) = 0$, and since $ge^{-i\theta_{\mathbf{x}}} \in C^\infty(\partial\Omega, \mathbb{S}^1)$, $\phi_0^{\mathbf{x}} \in C^\infty(\partial\Omega, \mathbb{R})$ is well defined [3].
- We let $\phi_* = \phi_*^{\mathbf{x}}, \phi = \phi^{\mathbf{x}} \in H^1$ be **the** solutions of

$$\begin{cases} -\Delta\phi_* = 0 & \text{in } \Omega \setminus \overline{\cup B(x_i, \rho_0)} \\ \phi_* = \phi_0 & \text{on } \partial\Omega \\ \partial_\nu\phi_* = -\sum_{j \neq i} \partial_\nu\theta_{x_j} & \text{on } \partial B(x_i, \rho_0), i = 1, \dots, d \end{cases}$$

and

$$\begin{cases} -\text{div}(U_\varepsilon^2 \nabla\phi) = \text{div}(U_\varepsilon^2 \nabla\theta_{\mathbf{x}}) & \text{in } \Omega \setminus \overline{\cup B(x_i, \rho_0)} \\ \phi = \phi_0 & \text{on } \partial\Omega \\ \partial_\nu\phi = -\sum_{j \neq i} \partial_\nu\theta_{x_j} & \text{on } \partial B(x_i, \rho_0), i = 1, \dots, d \end{cases}.$$

- We let $\psi = \phi - \phi_*$ be **the** solution of

$$\begin{cases} -\text{div}(U_\varepsilon^2 \nabla\psi) = \text{div}[(U_\varepsilon^2 - 1)(\nabla\theta_{\mathbf{x}} - \nabla\phi_*)] & \text{in } \Omega \setminus \overline{\cup B(x_i, \rho_0)} \\ \psi = 0 & \text{on } \partial\Omega \\ \partial_\nu\psi = 0 & \text{on } \partial B(x_i, \rho_0), i = 1, \dots, d \end{cases}.$$

Remark 3. 1. From Proposition 2, the functions ϕ_*, ϕ are s.t. $w_* = e^{i(\theta_{\mathbf{x}} + \phi_*)}$, $w = e^{i(\theta_{\mathbf{x}} + \phi_*)} \in \mathcal{I}_{\rho_0}(\mathbf{x})$ satisfy

$$\hat{\mathcal{I}}_{\rho_0, \mathbb{I}}(\mathbf{x}) = \frac{1}{2} \int_{\Omega \setminus \overline{\cup B(x_i, \rho_0)}} |\nabla w_*|^2 = \frac{1}{2} \int_{\Omega \setminus \overline{\cup B(x_i, \rho_0)}} |\nabla(\theta_{\mathbf{x}} + \phi_*)|^2$$

and

$$\hat{\mathcal{I}}_{\rho_0, \varepsilon}(\mathbf{x}) = \frac{1}{2} \int_{\Omega \setminus \overline{\cup B(x_i, \rho_0)}} U_\varepsilon^2 |\nabla w|^2 = \frac{1}{2} \int_{\Omega \setminus \overline{\cup B(x_i, \rho_0)}} U_\varepsilon^2 |\nabla(\theta_{\mathbf{x}} + \phi)|^2.$$

2. $\nabla\phi$ and $\nabla\phi_*$ are bounded independently of \mathbf{x} and ε_n in $L^2(\Omega \setminus \overline{\cup B(x_i, \rho_0)})$.

3. From a Poincaré inequality we have the existence of C_0 independent of \mathbf{x} s.t.

$$\|\psi\|_{L^2(\Omega \setminus \overline{\cup B(x_i, \rho_0)})} \leq C_0 \|\nabla\psi\|_{L^2(\Omega \setminus \overline{\cup B(x_i, \rho_0)})}.$$

Therefore, using a trace inequality in $\mathcal{R}(x_i, 2\rho_0, \rho_0)$ we obtain $\|\psi\|_{L^2(\partial B(x_i, \rho_0))} \leq C'_0$, C'_0 is independent of $\mathbf{x}, \varepsilon_n$.

4. We have $|\nabla\phi_*|$ which is bounded in $L^\infty(\Omega \setminus \overline{\cup B(x_i, \rho_0)})$

$$|\nabla\phi_*| \leq C_0 \text{ with } C_0 \text{ independent of } \mathbf{x}.$$

Indeed, with standard result of elliptic interior regularity, we have

$$\|\phi_*\|_{C^2(\partial B(x_i, 8\rho_0))}, \|\phi_*\|_{C^2(\partial B(c_i, 4\rho_0))} \leq C'_0.$$

Thus, from global regularity for the Laplacian, we have

$$\|\nabla\phi_*\|_{L^\infty(\Omega \setminus \overline{\cup B(c_i, 4\rho_0)})}, \|\nabla\phi_*\|_{L^\infty(\mathcal{R}(x_i, 8\rho_0, \rho_0))} \leq C''_0.$$

We let $\Omega_{\rho_0} = \Omega_{\rho_0}(\mathbf{x}) := \Omega \setminus \overline{\cup B(x_i, \rho_0)}$. This step is devoted to prove that $\int_{\Omega_{\rho_0}} |\nabla\psi|^2 \rightarrow 0$ when $\varepsilon_n \rightarrow 0$ uniformly on \mathbf{x} . This estimate will easily imply (E.1). Indeed

$$\begin{aligned} \hat{\mathcal{I}}_{\rho_0, \mathbb{I}}(\mathbf{x}) - \hat{\mathcal{I}}_{\rho_0, \varepsilon_n}(\mathbf{x}) &= \frac{1}{2} \int_{\Omega_{\rho_0}} U_{\varepsilon_n}^2 [|\nabla(\theta_{\mathbf{x}} + \phi_*)|^2 - |\nabla(\theta_{\mathbf{x}} + \phi)|^2] \\ &\quad + \frac{1}{2} \int_{\Omega_{\rho_0}} (1 - U_{\varepsilon_n}^2) |\nabla(\theta_{\mathbf{x}} + \phi_*)|^2 \\ &\leq C_0 \left(\|\nabla\psi\|_{L^2(\Omega_{\rho_0})} + \|1 - U_{\varepsilon_n}^2\|_{L^2(\Omega_{\rho_0})} \right) \rightarrow 0. \end{aligned}$$

Consequently we obtain

$$\hat{\mathcal{J}}_{\rho_0, \mathbb{I}}(\mathbf{x}) - \hat{\mathcal{J}}_{\rho_0, \varepsilon_n}(\mathbf{x}) \leq \hat{\mathcal{I}}_{\rho_0, \mathbb{I}}(\mathbf{x}) - \hat{\mathcal{I}}_{\rho_0, \varepsilon_n}(\mathbf{x}) + \eta_0 \leq \eta_0 + o_n(1) \leq 2\eta_0$$

which is exactly (E.1).

Thus it remains to establish that $\int_{\Omega_{\rho_0}} |\nabla\psi|^2 \rightarrow 0$ when $\varepsilon_n \rightarrow 0$ uniformly on \mathbf{x} :

$$\begin{aligned} \int_{\Omega_{\rho_0}} U_\varepsilon^2 |\nabla\psi|^2 &= \int_{\Omega_{\rho_0}} \operatorname{div}[(U_\varepsilon^2 - 1)(\nabla\theta_{\mathbf{x}} - \nabla\phi_*)]\psi \\ &= \int_{\Omega_{\rho_0}} (1 - U_\varepsilon^2)(\nabla\theta_{\mathbf{x}} - \nabla\phi_*) \cdot \nabla\psi + \int_{\partial\Omega_{\rho_0}} (U_\varepsilon^2 - 1)\partial_\nu(\theta_{\mathbf{x}} - \phi_*)\psi. \end{aligned}$$

From the L^2 bound on $\nabla\psi$ and the L^∞ bounds on $\nabla\phi_*$, $\nabla\theta_{\mathbf{x}}$ we have (with C_0 independent of \mathbf{x})

$$\begin{aligned} \int_{\Omega_{\rho_0}} U_\varepsilon^2 |\nabla\psi|^2 &\leq \left(\int_{\Omega_{\rho_0}} |1 - U_\varepsilon^2|^2 |\nabla\theta_{\mathbf{x}} - \nabla\phi_*|^2 \right)^{1/2} \left(\int_{\Omega_{\rho_0}} |\nabla\psi|^2 \right)^{1/2} + \\ &\quad + \left(\int_{\partial\Omega_{\rho_0}} (U_\varepsilon^2 - 1)^2 |\partial_\nu(\theta_{\mathbf{x}} - \phi_*)|^2 \right)^{1/2} \left(\int_{\partial\Omega_{\rho_0}} |\psi|^2 \right)^{1/2} \\ &\leq C_0 \left(\|1 - U_\varepsilon^2\|_{L^2(\Omega_{\rho_0})} + \|1 - U_\varepsilon^2\|_{L^2(\partial\Omega_{\rho_0})} \right). \end{aligned}$$

From Lemma 36 we have $\|1 - U_\varepsilon^2\|_{L^2(\partial\Omega_{\rho_0})} = \mathcal{O}(\lambda)$ uniformly in \mathbf{x} .

Therefore $\int_{\Omega \setminus \cup B(x_i, \rho_0)} |\nabla\psi|^2 \rightarrow 0$ when $\varepsilon_n \rightarrow 0$ uniformly on \mathbf{x} and (E.1) holds.

Step 2. We study the energies in $\mathcal{R}(x_i, \rho_0, \max(\delta, \lambda^2))$

Let $\kappa = \max(\lambda, \sqrt{\delta})$ and $w_n = e^{i\varphi_n}$ be a minimizer of $\hat{\mathcal{J}}_{\rho, \varepsilon_n}(\mathbf{x}_n)$ (φ_n is locally defined and its gradient is globally defined in $\Omega \setminus \cup B(x_i, \rho)$).

We prove that there is $r \in (\kappa^2, \kappa)$ s.t.

$$\frac{1}{2} \int_0^{2\pi} |\partial_\theta \varphi_n(x_i^n + re^{i\theta})|^2 d\theta \leq \pi + \frac{1}{\sqrt{|\ln \kappa|}} \quad \forall i = 1, \dots, d.$$

This estimate is obtained via a mean value argument. We first prove that

$$\mu_{\varepsilon_n}(\mathcal{R}(x_i^n, \kappa, \kappa^2), 1) = \mu_{\mathbb{I}}(\mathcal{R}(x_i^n, \kappa, \kappa^2), 1) + o_{\varepsilon_n}(1).$$

Indeed we let $\omega' \subset \mathbb{R}^2$ be s.t. $\bar{\omega} \subset \omega' \prec B(0, 1)$ and $\alpha'_\varepsilon = \begin{cases} b^2 & \text{in } \delta\mathbb{Z} \times \delta\mathbb{Z} + \lambda\delta \cdot \omega' \\ 1 & \text{otherwise} \end{cases}$. From

Lemma 31, we have $\alpha'_\varepsilon \leq a_\varepsilon^2 + W_\varepsilon$ with $\|W_\varepsilon\|_{L^\infty} = \mathcal{O}(\varepsilon^2)$. For $\rho \geq \delta$ and $x \in \mathbb{R}^2$, from Lemma 36, we have $\mathcal{H}^1[\{\alpha_\varepsilon = b^2\} \cap \partial B(x, \rho)] \leq 16\pi^2 \lambda \rho$. Therefore, using Lemma 35 we obtaine

$$\begin{aligned} \mu_{\mathbb{I}}(\mathcal{R}(x_i^n, \kappa, \kappa^2), 1) + \mathcal{O}(\lambda |\ln \kappa|) &\leq \mu_{\alpha'_\varepsilon}(\mathcal{R}(x_i^n, \kappa, \kappa^2), 1) \\ &\leq \mu_{\varepsilon_n}(\mathcal{R}(x_i^n, \kappa, \kappa^2), 1) \leq \mu_{\mathbb{I}}(\mathcal{R}(x_i^n, \kappa, \kappa^2), 1). \end{aligned}$$

Since for $s \in (\kappa^2, \kappa)$ we have $s \geq \delta$, we obtain

$$\mu_{\varepsilon_n}(\mathcal{R}(x_i^n, \kappa, \kappa^2), 1) = \mu_{\mathbb{I}}(\mathcal{R}(x_i^n, \kappa, \kappa^2), 1) + \mathcal{O}(\lambda |\ln \kappa|) = \pi |\ln \kappa| + o_{\varepsilon_n}(1).$$

Therefore from Corollary 7 and Lemma 34, $\frac{1}{2} \int_{\mathcal{R}(x_i^n, \kappa, \kappa^2)} U_{\varepsilon_n}^2 |\nabla w_n|^2 = \pi |\ln \kappa| + \mathcal{O}(1)$. And

from standard estimate we have $\int_0^{2\pi} |\partial_\theta \varphi_n(x_i^n + se^{i\theta})|^2 d\theta \geq 2\pi \quad \forall s \in (\kappa^2, \kappa)$.

We deduce that

$$2\pi d |\ln \kappa| + \mathcal{O}(1) \geq \int_{\cup \mathcal{R}(x_i^n, \kappa, \kappa^2)} |\nabla w_n|^2 \geq \int_{\kappa^2}^{\kappa} \frac{ds}{s} \sum_i \int_0^{2\pi} |\partial_\theta \varphi_n(x_i^n + se^{i\theta})|^2 d\theta.$$

Assume that such r does not exist, then we obtain that for $s \in (\kappa^2, \kappa)$

$$\sum_i \int_0^{2\pi} |\partial_\theta \varphi_n(x_i^n + se^{i\theta})|^2 d\theta > 2\pi d + \frac{2}{\sqrt{|\ln \kappa|}}$$

and consequently

$$\int_{\cup \mathcal{R}(x_i^n, \kappa, \kappa^2)} |\nabla w_n|^2 \geq |\ln \kappa| \left(2\pi d + \frac{2}{\sqrt{|\ln \kappa|}} \right) = 2\pi d |\ln \kappa| + \sqrt{|\ln \kappa|}.$$

Clearly this lower bound is in contradiction with $\frac{1}{2} \int_{\mathcal{R}(x_i^n, \kappa, \kappa^2)} U_{\varepsilon_n}^2 |\nabla w_n|^2 = \pi |\ln \kappa| + \mathcal{O}(1)$.

Let $h_i^n : \mathbb{S}^1 \rightarrow \mathbb{S}^1$, $h_i^n(e^{i\theta}) = w_n(x_i^n + re^{i\theta})$. We have $h_i^n \times \partial_\theta h_i^n = \partial_\theta \varphi_n(x_i^n + re^{i\theta})$. Thus from Step 2.: $\|h_i^n \times \partial_\theta h_i^n\|_{L^2(\mathbb{S}^1)}^2 \leq 2\pi d + 2/\sqrt{|\ln \kappa|}$. Consequently

$$\int_{\mathbb{S}^1} |h_i^n \times \partial_\theta h_i^n - 1|^2 = \int_{\mathbb{S}^1} \{ |h_i^n \times \partial_\theta h_i^n|^2 + 1 - 2h_i^n \times \partial_\theta h_i^n \} \leq 2/\sqrt{|\ln \kappa|} \rightarrow 0.$$

Therefore $h_i^n \times \partial_\theta h_i^n \rightarrow 1$ in $L^2(\mathbb{S}^1)$. Consequently, up to pass to a subsequence, we have the existence of $\alpha_i \in (-\pi, \pi]$ s.t. $\alpha_i^{-1} h_i^n e^{-i\theta} \rightarrow 1$ in $H^1(\mathbb{S}^1)$.

From Propositions 12 and 13 in [12] we have

$$\begin{aligned} \inf_{\substack{w \in H^1(\mathcal{R}(x_i^n, \rho_0, r), \mathbb{S}^1) \\ w(\rho_0 e^{i\theta}) = \alpha_i e^{i\theta} \\ w(re^{i\theta}) = h_i^n(e^{i\theta})}} \frac{1}{2} \int_{\mathcal{R}(x_i^n, \rho_0, r)} |\nabla w|^2 &= \inf_{\substack{w \in H^1(\mathcal{R}(x_i^n, \rho_0, r), \mathbb{S}^1) \\ w(\rho_0 e^{i\theta}) = \alpha_i e^{i\theta} \\ w(re^{i\theta}) = \alpha_i e^{i\theta}}} \frac{1}{2} \int_{\mathcal{R}(x_i^n, \rho_0, r)} |\nabla w|^2 + o_n(1) \\ &= \pi \ln \frac{\rho_0}{r} + o_n(1). \end{aligned}$$

Step 3. We conclude

We are going to construct a map $\tilde{w}_n \in \mathcal{J}_\rho(\mathbf{y}_n)$, $\max |y_i - b_i| \leq \delta$ and s.t.

$$\int_{\Omega \setminus \cup \overline{B}(y_i, \rho)} U_{\varepsilon_n}^2 |\nabla \tilde{w}_n|^2 + \eta_0 \leq \mathcal{J}_\rho(\mathbf{x}_n). \quad (\text{E.2})$$

Clearly (E.2) is in contradiction with the assumption: $J_\rho - \mathcal{J}_\rho(\mathbf{x}_n) \rightarrow 0$. Then this contradiction will imply that $\mathbf{a} = \lim \mathbf{x}_n$ minimizes W_g .

We let \mathbf{y}_n be s.t. $\max |y_i^n - b_i| \leq \delta$ and $x_i^n - y_i^n \in \delta\mathbb{Z} \times \delta\mathbb{Z}$ and we define

$$\tilde{w}_n(x) = \begin{cases} w_{\rho_0}^{\mathbf{y}_n}(x) & \text{in } x \in \Omega \setminus \cup \overline{B}(y_i^n, \rho) \\ \text{Cst}_{i,n} w^i(x - y_i^n + x_i^n) & \text{in } x \in \mathcal{R}(y_i^n, \rho_0, r) \\ w_n[x - y_i^n + x_i^n] & \text{in } x \in \mathcal{R}(y_i^n, r, \rho) \end{cases}$$

Here:

- $w_{\rho_0}^{\mathbf{y}_n}$ is a minimizer of $\hat{\mathcal{J}}_{\rho_0, \mathbf{I}}(\mathbf{y}_n)$,

- w^i is a minimizer of $\inf_{\substack{w \in H^1(\mathcal{R}(x_i^n, \rho_0, r), \mathbb{S}^1) \\ w(\rho_0 e^{i\theta}) = \alpha_i e^{i\theta} \\ w(re^{i\theta}) = h_i^n(e^{i\theta})}} \frac{1}{2} \int_{\mathcal{R}(x_i^n, \rho_0, r)} |\nabla w|^2$

- $\text{Cst}_{i,n} \in \mathbb{S}^1$ is a constant s.t. $\tilde{w}_n \in H^1(\Omega \setminus \overline{\cup B(y_i^n, \rho)}, \mathbb{S}^1)$
- w_n is the minimizer of $\hat{\mathcal{J}}_{\rho, \varepsilon_n}(\mathbf{x}_n)$ used in Step 2..

We now compare the energy of \tilde{w}_n and w_n .

$$\begin{aligned} \int_{\Omega \setminus \overline{\cup B(y_i^n, \rho)}} U_{\varepsilon_n}^2 |\nabla \tilde{w}_n|^2 &= \int_{\Omega \setminus \overline{\cup B(y_i^n, \rho_0)}} U_{\varepsilon_n}^2 |\nabla \tilde{w}_n|^2 + \int_{\cup_i \mathcal{R}(y_i^n, \rho_0, r)} U_{\varepsilon_n}^2 |\nabla \tilde{w}_n|^2 + \\ &\quad + \int_{\cup_i \mathcal{R}(y_i^n, r, \rho)} U_{\varepsilon_n}^2 |\nabla \tilde{w}_n|^2. \end{aligned}$$

From Step 1. (the definition of ρ_0 and Estimate (E.1)), we have

$$\begin{aligned} \frac{1}{2} \int_{\Omega \setminus \overline{\cup B(y_i^n, \rho_0)}} U_{\varepsilon_n}^2 |\nabla \tilde{w}_n|^2 &\leq \pi d |\ln \rho_0| + W_g(\mathbf{y}_n) + \eta_0 + o_n(1) \\ &\leq \pi d |\ln \rho_0| + W_g(\mathbf{x}_n) - 10\eta_0 \\ &\leq \frac{1}{2} \int_{\Omega \setminus \overline{\cup B(x_i^n, \rho_0)}} U_{\varepsilon_n}^2 |\nabla w_n|^2 - \eta_0. \end{aligned}$$

From Step 2.,

$$\frac{1}{2} \int_{\cup_i \mathcal{R}(y_i^n, \rho_0, r)} U_{\varepsilon_n}^2 |\nabla \tilde{w}_n|^2 = \pi d \ln \frac{\rho_0}{r} + o_n(1) \leq \frac{1}{2} \int_{\cup_i \mathcal{R}(x_i^n, \rho_0, r)} U_{\varepsilon_n}^2 |\nabla w_n|^2 + o_n(1).$$

From Lemma 31

$$\int_{\cup_i \mathcal{R}(y_i^n, r, \rho)} U_{\varepsilon_n}^2 |\nabla \tilde{w}_n|^2 = \int_{\cup_i \mathcal{R}(x_i^n, r, \rho)} U_{\varepsilon_n}^2 |\nabla w_n|^2 + o_n(1).$$

Therefore we obtain (E.2) and consequently Proposition 8 holds.

E.3 Proof of Proposition 9

The strategy to prove Proposition 9 is the following:

- Step 1. We first obtain informations about almost minimizing configurations for $I_{\delta, \varepsilon}$ (*i.e* the domain Ω is perforated by discs with radius δ).
- Step 2. We make the description of almost minimizing families of points $(x_\varepsilon)_\varepsilon$ for the minimization problem $\inf_{x_0 \in \mathbb{R}^2} \mu_\varepsilon(\mathcal{R}(x_0, \delta, \lambda \delta^{3/2}), 1)$.
- Step 3. We estimate $\inf_{x_0 \in \mathbb{R}^2} \mu_\varepsilon(\mathcal{R}(x_0, \lambda \delta^{3/2}, \rho), 1)$ and we conclude.

Step 1. We study almost minimizing configurations for $I_{\delta, \varepsilon}$

We prove that $\{(x_1^\varepsilon, d_1), \dots, (x_N^\varepsilon, d_n)\}$ is an almost minimal configuration for $I_{\delta, \varepsilon}$ **if and only if** $N = 1$, $d_i = 1$ and there is $\eta_0 > 0$ s.t. $\text{dist}(x_i^\varepsilon, \partial\Omega), |x_i - x_j| \geq \eta_0$.

First note that for $\eta_0 > 0$ and $x_1, \dots, x_d \in \Omega$ s.t. $\text{dist}(x_i, \partial\Omega), |x_i - x_j| \geq \eta_0$ we have easily

$$\hat{\mathcal{I}}_{\delta, \varepsilon} \leq \pi d |\ln \delta| + C(\eta_0)$$

with $C(\eta_0)$ which depends only on Ω , g and η_0 .

We first consider $\{(x_1^\varepsilon, d_1), \dots, (x_N^d, d_n)\}$ which is an almost minimal configuration for $I_{\delta, \varepsilon}$.

We argue as in the proof of Proposition 5 (Assertions 1 and 2, see Subsections D.3 and D.4). We use the separation process defined Subsection C.1 and the associated natural partition of $\Omega \setminus \cup \overline{B(x_i^\varepsilon, \delta)}$ (see Subsection C.2).

Here the key ingredients are Lemmas 35 and 36 (which replace the periodic structure of the pinning term). Combining both lemmas we get that if $1 \geq R > r \geq \delta$, then

$$\mu_\varepsilon(\mathcal{R}(x_0, R, r), 1) = \pi \ln \frac{R}{r} + \mathcal{O}(\lambda \ln \frac{R}{r}) = \pi \ln \frac{R}{r} + o_\varepsilon(1).$$

Here we used the assumption $\lambda |\ln \delta| \rightarrow 0$.

Therefore we get: $\{(x_1^\varepsilon, d_1), \dots, (x_N^d, d_n)\}$ is an almost minimal configuration for $I_{\delta, \varepsilon}$ then $N = 1$, $d_i = 1$ and there is $\eta_0 > 0$ s.t. $\text{dist}(x_i^\varepsilon, \partial\Omega), |x_i - x_j| \geq \eta_0$. (This is proved by contradiction exactly as in Subsection D.3 and D.4). Moreover $\hat{\mathcal{I}}_{\delta, \varepsilon} \leq \pi d |\ln \delta| + C(\eta_0)$. Therefore $I_{\delta, \varepsilon} = \pi d |\ln \delta| + \mathcal{O}(1)$.

Conversely, since $I_{\delta, \varepsilon} = \pi d |\ln \delta| + \mathcal{O}(1)$, for $\eta_0 > 0$ and $x_1^\varepsilon, \dots, x_d^\varepsilon \in \Omega$ s.t. $\text{dist}(x_i^\varepsilon, \partial\Omega), |x_i^\varepsilon - x_j^\varepsilon| \geq \eta_0$, we have $(x_1^\varepsilon, \dots, x_d^\varepsilon)$ which is an almost minimizing configuration for $I_{\delta, \varepsilon}$.

Step 2. We study $\inf_{x_0 \in \mathbb{R}^2} \mu_\varepsilon(\mathcal{R}(x_0, \delta, \lambda \delta^{3/2}), 1)$

For $j \in \{1, \dots, P\}$, we denote: $\omega_\varepsilon^j := \cup_{i \in \mathcal{M}_j^\varepsilon} y_{i,j}^\varepsilon + \lambda \delta^j \omega$.

Letting $x_\varepsilon \in \omega_\varepsilon$ et $c > 0$ (independent of ε) s.t. $B(x_\varepsilon, c\lambda\delta) \subset \omega_\varepsilon^1$, we may easily prove that

$$\inf_{x_0 \in \Omega} \mu_\varepsilon(\mathcal{R}(x_\varepsilon, \delta, \lambda \delta^{3/2}), 1) \leq \pi b^2 |\ln \delta^{1/2}| + \pi |\ln \lambda| + \mathcal{O}(1).$$

We prove that for a fixed constant $C_0 > 0$ and $\varepsilon \leq \rho \leq \delta$, if we have $(x_\varepsilon)_\varepsilon \subset \Omega$ which is s.t.

$$\mu_\varepsilon(\mathcal{R}(x_\varepsilon, \delta, \lambda \delta^{3/2}), 1) \leq \inf_{x_0 \in \Omega} \mu_\varepsilon(\mathcal{R}(x_\varepsilon, \delta, \lambda \delta^{3/2}), 1) + C_0,$$

then there is $c > 0$ independent of ε and $(x_\varepsilon)_\varepsilon$ s.t. $B(x_\varepsilon, c\lambda\delta) \subset \omega_\varepsilon$, i.e. $B(x_\varepsilon, c\lambda\delta) \subset y_{l,1}^\varepsilon + \lambda \delta \omega$ with $y_{l,1}^\varepsilon \in \mathcal{M}_1^\varepsilon$.

Up to pass to a sequence $\varepsilon_n \downarrow 0$ we may assume that one of these cases occurs

Case 1. $x_\varepsilon \in \omega_\varepsilon \setminus \omega_\varepsilon^1$,

Case 2. $x_\varepsilon \notin \omega_\varepsilon$,

Case 3. $x \in \omega_\varepsilon^1$ and $\text{dist}(x_\varepsilon, \partial\omega_\varepsilon^1)/\lambda\delta \rightarrow 0$.

Let

$$\mathfrak{a}_\varepsilon = \begin{cases} \lambda \delta^{3/2} & \text{in Case 1} \\ \max\{\text{dist}(x_\varepsilon, \partial\omega_\varepsilon), \lambda \delta^{3/2}\} & \text{in Case 2} \\ \max\{\text{dist}(x_\varepsilon, \partial\omega_\varepsilon), \lambda \delta^{3/2}\} & \text{in Case 3} \end{cases}$$

One may easily adapt the proof of Lemma 36 to prove that for $j \in \{1, \dots, P\}$ we have $\text{dist}(x, \omega_\varepsilon^j) \geq \delta^j/2$, then for $s > 0$, we have $\mathcal{H}^1(\partial B(x, s) \cap \omega_\varepsilon^j) \leq C\lambda$ with C independent of x , s and ε .

Consequently, from the construction of the pinning term (the dilution of the inclusions implies that $\text{dist}(\omega_\varepsilon^j, \omega_\varepsilon^{j'}) \geq \delta^{\min\{j, j'\}}$), we have:

Case 1. $\mathcal{H}^1(\omega_\varepsilon \cap \partial B(x_\varepsilon, s)) \leq C\lambda$ for $s \geq \lambda \delta^{3/2}$ (here we used the fact the since

$x_\varepsilon \in \omega_\varepsilon \setminus \omega_\varepsilon^1$, then if we denote $\tilde{\omega}_\varepsilon \subset \omega_\varepsilon^{j_0}$ the connected component of ω_ε which contains x_ε , then $\mathcal{R}(x_\varepsilon, \delta, \lambda\delta^{3/2}) \cap \tilde{\omega}_\varepsilon = \emptyset$ and $\text{dist}(x_\varepsilon, \omega_\varepsilon^j \setminus \tilde{\omega}_\varepsilon) \geq \delta^j$ for $j = \{1, \dots, P\}$.

Therefore we have:

$$\mu_\varepsilon(\mathcal{R}(x_\varepsilon, \delta, \lambda\delta^{3/2}), 1) \geq \pi |\ln \lambda\delta^{1/2}| - \mathcal{O}(1)$$

and thus $(x_\varepsilon)_\varepsilon$ cannot be an almost minimizing configuration.

Case 2. We let $j_0 = \min\{j \in \{1, \dots, P\} \mid \text{dist}(x_\varepsilon, \partial\omega_\varepsilon) = \text{dist}(x_\varepsilon, \partial\omega_\varepsilon^j)\}$. Since $x_\varepsilon \notin \omega_\varepsilon$, from the dilution of the inclusions, if there is $j' \neq j_0$ s.t. $\text{dist}(x_\varepsilon, \partial\omega_\varepsilon^{j'}) = \text{dist}(x_\varepsilon, \partial\omega_\varepsilon^{j_0}) = \text{dist}(x_\varepsilon, \partial\omega_\varepsilon)$, then we have $\mathfrak{a}_\varepsilon = \text{dist}(x_\varepsilon, \partial\omega_\varepsilon^{j_0}) \geq \delta^{j_0}/2 \geq \delta^{j'}$. Therefore for $s \geq \mathfrak{a}_\varepsilon + \lambda\delta^{j_0}$, we have $\mathcal{H}^1(\partial B(x_\varepsilon, s) \cap \omega_\varepsilon) \leq C\lambda$. On the other hand, because $x_\varepsilon \notin \omega_\varepsilon$, we have (using the dilution of the inclusions) for $\delta > s > 0$, $\mathcal{H}^1(\partial B(x_\varepsilon, s) \cap \omega_\varepsilon) \leq (1 + \mathcal{O}(\lambda))\pi s$ (here we used the fact that, from the dilution of the inclusions, we have $\partial B(x_\varepsilon, s) \cap \omega_\varepsilon$ which is at most a half-circle pulse "small" pieces of circle).

If $\mathfrak{a}_\varepsilon \geq \delta$, then we have

$$\mu_\varepsilon(\mathcal{R}(x_\varepsilon, \delta, \lambda\delta^{3/2}), 1) \geq \pi |\ln \lambda\delta^{1/2}| - \mathcal{O}(1).$$

Otherwise $\mathfrak{a}_\varepsilon \leq \delta$ and we have

$$\begin{aligned} \mu_\varepsilon(\mathcal{R}(x_\varepsilon, \delta, \lambda\delta^{3/2}), 1) &= \mu_\varepsilon(\mathcal{R}(x_\varepsilon, \delta, \mathfrak{a}_\varepsilon + \lambda\delta^{j_0}), 1) + \mu_\varepsilon(\mathcal{R}(x_\varepsilon, \mathfrak{a}_\varepsilon + \lambda\delta^{j_0}, \mathfrak{a}_\varepsilon), 1) + \\ &\quad + \mu_\varepsilon(\mathcal{R}(x_\varepsilon, \mathfrak{a}_\varepsilon, \lambda\delta^{3/2}), 1) + \mathcal{O}(1) \end{aligned}$$

with

- $\mu_\varepsilon(\mathcal{R}(x_\varepsilon, \delta, \mathfrak{a}_\varepsilon + \lambda\delta^{j_0}), 1) \geq \pi \ln \frac{\delta}{\mathfrak{a}_\varepsilon + \lambda\delta^{j_0}} + o_\varepsilon(1)$. Here we used the fact that $\partial B(x_\varepsilon, s)$ has a small intersection with ω_ε when $s \geq \mathfrak{a}_\varepsilon + \lambda\delta^{j_0}$ combined with Lemma 35.
- $\mu_\varepsilon(\mathcal{R}(x_\varepsilon, \mathfrak{a}_\varepsilon + \lambda\delta^{j_0}, \mathfrak{a}_\varepsilon), 1) \geq \gamma\pi \ln \frac{\mathfrak{a}_\varepsilon + \lambda\delta^{j_0}}{\mathfrak{a}_\varepsilon} + \mathcal{O}(1)$ with $\gamma \in (b^2, 1)$ (γ is independent of ε). Here we used the fact that $\mathcal{H}^1(\partial B(x_\varepsilon, s) \cap \omega_\varepsilon) \leq (1 + \mathcal{O}(\lambda))\pi s$ combined with Lemma 35.
- $\mu_\varepsilon(\mathcal{R}(x_\varepsilon, \mathfrak{a}_\varepsilon, \lambda\delta^{3/2}), 1) = \pi \ln \frac{\mathfrak{a}_\varepsilon}{\lambda\delta^{3/2}} + \mathcal{O}(1)$. Here, we used the fact that $\mathcal{R}(x_\varepsilon, \mathfrak{a}_\varepsilon, \lambda\delta^{3/2}) \cap \omega_\varepsilon = \emptyset$.

There, we have

$$\begin{aligned} \mu_\varepsilon(\mathcal{R}(x_\varepsilon, \delta, \lambda\delta^{3/2}), 1) &\geq \pi \ln \frac{\delta}{\mathfrak{a}_\varepsilon + \lambda\delta^{j_0}} + \gamma\pi \ln \frac{\mathfrak{a}_\varepsilon + \lambda\delta^{j_0}}{\mathfrak{a}_\varepsilon} + \pi \ln \frac{\mathfrak{a}_\varepsilon}{\lambda\delta^{3/2}} + \mathcal{O}(1) \\ &\geq \pi |\ln \lambda\delta^{1/2}| + \pi(\gamma - 1) \ln \frac{\mathfrak{a}_\varepsilon + \lambda\delta^{j_0}}{\mathfrak{a}_\varepsilon} + \mathcal{O}(1) \\ (\mathfrak{a}_\varepsilon \geq \lambda\delta^{3/2}) &\geq \pi |\ln(\lambda\delta^{1/2})| + \pi(\gamma - 1) \ln(1 + \delta^{-1/2}) + \mathcal{O}(1) \\ &\geq \pi b^2 |\ln \delta^{1/2}| + \pi |\ln \lambda| + \pi(\gamma - b^2) \ln \delta^{-1/2} + \mathcal{O}(1) \end{aligned}$$

with $\pi(\gamma - b^2) \ln \delta^{-1/2} \rightarrow +\infty$. Therefore $(x_\varepsilon)_\varepsilon$ cannot be an almost minimizing configuration.

Case 3. If we denote $\tilde{\omega}_\varepsilon$ the connected component of ω_ε^1 which contained x_ε , from the

dilution of the inclusions, we have $\text{dist}(x_\varepsilon, \omega_\varepsilon \setminus \tilde{\omega}_\varepsilon) \geq \delta$. Therefore, from Lemmas 35 and 36, we have the existence of $\gamma \in (b^2, 1)$ s.t.

$$\begin{aligned} \mu_\varepsilon(\mathcal{R}(x_\varepsilon, \delta, \lambda\delta^{3/2}), 1) &= \mu_\varepsilon(\mathcal{R}(x_\varepsilon, \delta, \mathfrak{a}_\varepsilon + \lambda\delta), 1) + \mu_\varepsilon(\mathcal{R}(x_\varepsilon, \mathfrak{a}_\varepsilon + \lambda\delta, \mathfrak{a}_\varepsilon), 1) + \\ &\quad + \mu_\varepsilon(\mathcal{R}(x_\varepsilon, \mathfrak{a}_\varepsilon, \lambda\delta^{3/2}), 1) + \mathcal{O}(1) \\ &\geq \pi \ln \frac{\delta}{\mathfrak{a}_\varepsilon + \lambda\delta} + \pi\gamma \ln \frac{\mathfrak{a}_\varepsilon + \lambda\delta}{\mathfrak{a}_\varepsilon} + \pi b^2 \ln \frac{\mathfrak{a}_\varepsilon}{\lambda\delta^{3/2}} + \mathcal{O}(1) \\ \left(\frac{\mathfrak{a}_\varepsilon}{\lambda\delta} \rightarrow 0\right) &\geq \pi |\ln \lambda| + \pi(\gamma - b^2) \ln \frac{\lambda\delta}{\mathfrak{a}_\varepsilon} + \pi b^2 |\ln \delta^{1/2}| + \mathcal{O}(1). \end{aligned}$$

Consequently $(x_\varepsilon)_\varepsilon$ cannot be an almost minimizing configuration.

Step 3. We study $\inf_{x_0 \in \mathbb{R}^2} \mu_\varepsilon(\mathcal{R}(x_0, \lambda\delta^{3/2}, \rho), 1)$ and we conclude

It is obvious that $\inf_{x_0 \in \mathbb{R}^2} \mu_\varepsilon(\mathcal{R}(x_0, \lambda\delta^{3/2}, \rho), 1) = \pi b^2 \ln \frac{\lambda\delta^{3/2}}{\rho}$. Now we are in position to conclude. On the one hand, for $\eta_0, c > 0$ and a configuration of points/degrees $\{(x_1^\varepsilon, d_1), \dots, (x_N^\varepsilon, d_N)\}$ s.t. $d_i = 1$, $|x_i^{\rho, \varepsilon} - x_j^{\rho, \varepsilon}|, \text{dist}(x_i^{\rho, \varepsilon}, \partial\Omega) \geq \eta_0$ and $B(x_i^{\rho, \varepsilon}, c\lambda\delta) \subset \omega_\varepsilon^1$ for all $i \neq j$, $i, j \in \{1, \dots, N\}$, we have $\hat{I}_{\rho, \varepsilon}(\mathbf{x}_\varepsilon) = I_{\rho, \varepsilon} + \mathcal{O}(1)$.

On the other hand, for $\varepsilon_n \downarrow 0$, if either there is $i \in \{1, \dots, N\}$ s.t. $d_i > 1$ or $\text{dist}(x_i^{\rho, \varepsilon}, \partial\Omega) \rightarrow 0$ or there are $i \neq j$ s.t. $|x_i - x_j| \rightarrow 0$, then the configuration of points/degrees cannot be almost minimal for $I_{\delta, \varepsilon_n}$ and thus it cannot be almost minimal for I_{ρ, ε_n} .

Moreover, if there is i s.t. $x_i^{\varepsilon_n} \notin \omega_\varepsilon^1$ or $\text{dist}(x_i^{\varepsilon_n}, \partial\omega_\varepsilon^1)/(\lambda\delta) \rightarrow 0$, then $(x_i^{\varepsilon_n})_n$ cannot be an almost minimizing configuration for $\inf_{x_0 \in \mathbb{R}^2} \mu_\varepsilon(\mathcal{R}(x_0, \delta, \lambda\delta^{3/2}), 1)$. And thus $\{(x_1^{\varepsilon_n}, d_1), \dots, (x_N^{\varepsilon_n}, d_N)\}$ cannot be an almost minimal configuration for I_{ρ, ε_n} .

The rest of the Proposition is obtained exactly as Corollary 7.

F Proof of Proposition 20

We use the *unfolding operator* (see [8], definition 2.1). We define, for $\Omega_0 \subset \mathbb{R}^2$ an open set, $p \in (1, \infty)$ and $\delta > 0$:

$$\begin{aligned} \mathcal{T}_\delta : L^p(\Omega_0) &\rightarrow L^p(\Omega_0 \times Y) \\ \phi &\mapsto \mathcal{T}_\delta(\phi)(x, y) = \begin{cases} \phi\left(\delta \left[\frac{x}{\delta}\right] + \delta y\right) & \text{for } (x, y) \in \Omega_\delta^{\text{incl}} \times Y \\ 0 & \text{for } (x, y) \in \Lambda_\delta \times Y \end{cases} \end{aligned}$$

and

$$\Omega_\delta^{\text{incl}} := \bigcup_{\substack{Y_\delta^K \subset \Omega_0 \\ Y_\delta^K = \delta(K+Y), K \in \mathbb{Z}^2}} \overline{Y_\delta^K}, \Lambda_\delta := \Omega_0 \setminus \Omega_\delta^{\text{incl}} \text{ and } \left[\frac{x}{\delta}\right] := \left(\left[\frac{x_1}{\delta}\right], \left[\frac{x_2}{\delta}\right]\right) \in \mathbb{Z}^2.$$

Here, for $s \in \mathbb{R}$, $[s]$ is the integer part of s .

We will use the following results:

$$\mathcal{T}_\delta \text{ is linear and continuous, of norm at most 1 ([8], Proposition 2.5),} \quad (\text{F.1})$$

$$\mathcal{T}_\delta(\phi\psi) = \mathcal{T}_\delta(\phi)\mathcal{T}_\delta(\psi) \text{ ([8], equation (2.2)),} \quad (\text{F.2})$$

$$\delta\mathcal{T}_\delta(\nabla\phi)(x, y) = \nabla_y \mathcal{T}_\delta(\phi)(x, y) \text{ for } \phi \in W^{1,p}(\Omega_0) \text{ ([8], equation (3.1)),} \quad (\text{F.3})$$

$$\text{for } \phi \in L^1(\Omega_0), \text{ we have } \int_{\Omega_\delta^{\text{incl}}} \phi = \int_{\Omega_0 \times Y} \mathcal{T}_\delta(\phi_\delta) \text{ ([8], Proposition. 2.5 (i)).} \quad (\text{F.4})$$

If $\phi_\delta \in H^1(\Omega_0)$ is such that $\phi_\delta \rightharpoonup \phi_0$ in H^1 , then, up to subsequence, there exists $\hat{\phi} \in L^2(\Omega_0, H_{\text{per}}^1(Y))$ s.t.:

$$\mathcal{T}_\delta(\phi_\delta) \rightarrow \phi_0 \text{ and } \mathcal{T}_\delta(\nabla \phi_\delta) \rightharpoonup \nabla \phi_0 + \nabla_y \hat{\phi} \text{ in } L^2(\Omega_0 \times Y) \text{ ([8], Theorem 3.5).} \quad (\text{F.5})$$

Here $H_{\text{per}}^1(Y)$ stands for the set of functions $\phi \in H^1(Y)$ s.t. the extending of ϕ by Y -periodicity is in $H_{\text{loc}}^1(\mathbb{R}^2)$ (see [9], section 3.4).

In order to define properly the homogenized matrix \mathcal{A} we recall a classical result (see Theorem 4.27 in [9]).

Proposition 37. *Let $H_0 \in L^\infty(Y, [b^2, 1])$. For all $f \in (H_{\text{per}}^1(Y))'$ s.t. f annihilates the constants there exists a unique solution $h \in H_{\text{per}}^1(Y)$ of*

$$\text{div}(H_0 \nabla_y h) = f \text{ and } \mathcal{M}_Y(h) = \int_Y h = 0.$$

Using the previous theorem we denote $\chi_j \in H_{\text{per}}^1(Y)$ the unique solution of

$$\text{div}(H_0 \nabla_y \chi_j) = \partial_{y_j}(H_0) \text{ and } \mathcal{M}_Y(\chi_j) = 0. \quad (\text{F.6})$$

With these auxiliary functions, we can give an explicit expression of \mathcal{A} the homogenized matrix of $H_0(\frac{\cdot}{\delta})\text{Id}_{\mathbb{R}^2}$ (see Theorem 6.1 in [9]):

$$\mathcal{A} = \int_Y H_0 \begin{pmatrix} 1 - \partial_{y_1} \chi_1 & -\partial_{y_1} \chi_2 \\ -\partial_{y_2} \chi_1 & 1 - \partial_{y_2} \chi_2 \end{pmatrix} = \int_Y H_0 (\text{Id}_{\mathbb{R}^2} - \nabla_y \chi), \chi = (\chi_1, \chi_2).$$

For the convenience of the reader we restate, in larger detail, Proposition 20.

Proposition. *Let $\Omega_0 \subset \mathbb{R}^2$ be a smooth bounded open set and let $v_n \in H^2(\Omega_0, \mathbb{C})$ be s.t.*

1. $|v_n| \leq 1$ and $\int_{\Omega_0} (1 - |v_n|^2)^2 \rightarrow 0$,
2. $v_n \rightharpoonup v_*$ in $H^1(\Omega_0)$ and $v_* \in H^1(\Omega_0, \mathbb{S}^1)$,
3. there is $H_n \in W^{1,\infty}(\Omega_0, [b^2, 1])$ and $\delta_n \downarrow 0$ s.t. $\mathcal{T}_{\delta_n}(H_n) \rightarrow H_0$ in $L^2(\Omega_0 \times Y)$ with H_0 independent of $x \in \Omega_0$,
4. $-\text{div}(H_n \nabla v_n) = v_n f_n(x)$, $f_n \in L^\infty(\Omega_0, \mathbb{R})$.

Then v_* is the solution of

$$-\text{div}(\mathcal{A} \nabla v_*) = (\mathcal{A} \nabla v_* \cdot \nabla v_*) v_*.$$

Here \mathcal{A} is the homogenized matrix of $H_0(\frac{\cdot}{\delta})\text{Id}_{\mathbb{R}^2}$ given by

$$\mathcal{A} = \int_Y H_0 \begin{pmatrix} 1 - \partial_{y_1} \chi_1 & -\partial_{y_1} \chi_2 \\ -\partial_{y_2} \chi_1 & 1 - \partial_{y_2} \chi_2 \end{pmatrix}.$$

Proof. In order to keep notations simple, we write, in what follows, δ rather than δ_n .

Since f_n is real valued, we have that $\operatorname{div}(H_n \nabla v_n) \times v_n = 0$. From (F.1) and (F.2), we obtain

$$\operatorname{div}_y [\mathcal{T}_\delta(H_n)(x, y) \mathcal{T}_\delta(\nabla v_n)(x, y)] \times \mathcal{T}_\delta(v_n)(x, y) = 0 \text{ in } \Omega_0 \times Y. \quad (\text{F.7})$$

Note that from the assumptions and (F.1),(F.5), passing to a subsequence, there is $\hat{w} \in L^2(\Omega_0, H_{\text{per}}^1(Y))$ s.t.

$$\mathcal{T}_\delta(v_n)(x, y) \rightarrow v_*(x), \mathcal{T}_\delta(\nabla v_n)(x, y) \rightharpoonup \nabla v_*(x) + \nabla_y \hat{w}(x, y) \text{ in } L^2(\Omega_0 \times Y)$$

and

$$\mathcal{T}_\delta(H_n)(x, y) \rightarrow H_0(y) \text{ in } L^2(\Omega_0 \times Y).$$

Thus we obtain the convergence:

$$\operatorname{div}_y [\mathcal{T}_\delta(H_n)(x, y) \mathcal{T}_\delta(\nabla v_n)(x, y)] \times \mathcal{T}_\delta(v_n)(x, y) \rightharpoonup \operatorname{div}_y [H_0(\nabla v_* + \nabla_y \hat{w})] \times v_* \text{ in } L^2(\Omega_0 \times H^{-1}(Y)).$$

Consequently,

$$\operatorname{div}_y [H_0(\nabla v_* + \nabla_y \hat{w})] \times v_* = 0.$$

Since v_* is independent of $y \in Y$, the previous assertion is equivalent to

$$-\operatorname{div}_y [H_0 \nabla_y (\hat{w} \times v_*)] = (\nabla_y H_0 \cdot \nabla v_*) \times v_*,$$

which in turn is equivalent to

$$-\operatorname{div}_y [H_0 \nabla_y (\hat{w} \times v_*)] = \sum_i \partial_{y_i} H_0 (\partial_i v_* \times v_*).$$

Hence, from Proposition 37 and (F.6), we obtain

$$\hat{w} \times v_* = - \sum_i \chi_i (\partial_i v_* \times v_*) = -\chi \cdot (\nabla v_* \times v_*), \chi = (\chi_1, \chi_2). \quad (\text{F.8})$$

Let $\psi \in \mathcal{D}(\Omega_0)$ and n sufficiently large s.t. $\operatorname{Supp}(\psi) \subset \Omega_\delta^{\text{incl}}$. Since $-\operatorname{div} [H_n \nabla v_n \times v_n] = 0$, we have

$$\int_{\Omega_\delta^{\text{incl}}} H_n \nabla v_n \times v_n \cdot \nabla \psi = 0.$$

This identity combined with (F.4) implies that

$$\int_{\Omega_0 \times Y} \mathcal{T}_\delta [H_n (\nabla v_n \times v_n) \cdot \nabla \psi] = 0.$$

Therefore, using (F.3) and (F.5), we obtain:

$$\begin{aligned} 0 &= \int_{\Omega_0 \times Y} \mathcal{T}_\delta [H_n (\nabla v_n \times v_n) \cdot \nabla \psi] &= \int_{\Omega_0 \times Y} \mathcal{T}_\delta(H_n) \mathcal{T}_\delta(\nabla v_n) \times \mathcal{T}_\delta(v_n) \cdot \mathcal{T}_\delta(\nabla \psi) \\ & &\xrightarrow{n \rightarrow \infty} \int_{\Omega_0 \times Y} H_0 [\nabla v_* \times v_* + \nabla_y (\hat{w} \times v_*)] \cdot \nabla \psi. \end{aligned}$$

Finally, for all $\psi \in \mathcal{D}(\Omega_0)$, using (F.8), we have

$$\begin{aligned} 0 &= \int_{\Omega_0 \times Y} H_0 \nabla v_* \times v_* [\operatorname{Id}_{\mathbb{R}^2} - \nabla_y \chi] \cdot \nabla \psi &= \int_{\Omega_0} \left(\left\{ \int_Y H_0 [\operatorname{Id}_{\mathbb{R}^2} - \nabla_y \chi] \right\} \nabla v_* \times v_* \right) \nabla \psi \\ & &= - \int_{\Omega_0} -\operatorname{div} (\mathcal{A} \nabla v_* \times v_*) \psi. \end{aligned}$$

Here $\mathcal{A} = \int_Y H_0 (\text{Id}_{\mathbb{R}^2} - \nabla_y \chi)$.

Thus $-\text{div}(\mathcal{A}\nabla v_* \times v_*) = 0$. Note that, since H_0 and χ are independent of x , \mathcal{A} is a constant matrix. This fact combined with the equation $-\text{div}(\mathcal{A}\nabla v_* \times v_*) = 0$ implies that v_* satisfies

$$-\text{div}(\mathcal{A}\nabla v_*) = (\mathcal{A}\nabla v_* \cdot \nabla v_*)v_*. \quad (\text{F.9})$$

Indeed, we can always consider φ_* which is locally defined in Ω_0 and whose gradient is globally defined and in $L^2(\Omega_0, \mathbb{R}^2)$ s.t. $v_* = e^{i\varphi_*}$.

Since $v_* \times \nabla v_* = \nabla \varphi_*$ we obtain that $\text{div}(\mathcal{A}\nabla \varphi_*) = 0$. Identity (F.9) follows from the equation of φ_* and the fact that $|\nabla \varphi_*|^2 = |\nabla v_*|^2$. □

References

- [1] A. Aftalion, E. Sandier, and S. Serfaty. Pinning Phenomena in the Ginzburg-Landau model of Superconductivity. *J. Math. Pures Appl.*, 80(3):339–372, 2001.
- [2] P. Bauman, N. Carlson, and D. Phillips. On the zeros of solutions to Ginzburg-Landau type systems. *SIAM J. Math. Anal.*, 24(5):1283–1293, 1993.
- [3] F. Bethuel, H. Brezis, and F. Hélein. Asymptotics for the minimization of a Ginzburg-Landau functional. *Calc. Var. Partial Differential Equations*, 1(2):123–148, 1993.
- [4] F. Bethuel, H. Brezis, and F. Hélein. *Ginzburg-Landau Vortices*. Progress in Nonlinear Differential Equations and their Applications, 13. Birkhäuser Boston Inc., Boston, MA, 1994.
- [5] F. Bethuel, G. Orlandi, and D. Smets. Improved estimates for the Ginzburg-Landau equation: the elliptic case. *Ann. Sc. Norm. Super. Pisa Cl. Sci. (5)*, 4(2):319–355, 2005.
- [6] H. Brezis. Équations de Ginzburg-Landau et singularités. Notes de cours rédigées par Vicențiu Rădulescu. <http://inf.ucv.ro/radulescu/articles/coursHB.pdf>, 2001.
- [7] H. Brezis, F. Merle, and T. Rivière. Quantization effects for $-\Delta u = u(1 - |u|^2)$ in \mathbb{R}^2 . *Arch. Rational Mech. Anal.*, 126(1):35–58, 1994.
- [8] D. Cioranescu, A. Damlamian, and G. Griso. The periodic unfolding method in homogenization. *SIAM J. Math. Anal.*, 40(4):1585–1620, 2008.
- [9] D. Cioranescu and P. Donato. *An Introduction to Homogenization*, volume 17 of *Oxford Lecture Series in Mathematics and its Applications*. The Clarendon Press Oxford University Press, 1999.
- [10] M. Comte and P. Mironescu. The behavior of a ginzburg-landau minimizer near its zeroes. *Calc. Var. Partial Differential Equations*, 4(4):323–340, 1996.
- [11] M. Dos Santos, P. Mironescu, and O. Misiats. The Ginzburg-Landau functional with a discontinuous and rapidly oscillating pinning term. Part I: the zero degree case. *Commun. Contemp. Math.*, to appear.

- [12] M. Dos Santos and O. Misiats. The Ginzburg-Landau functional with a discontinuous pinning term. Finitely many dilute inclusions case. *submitted*.
- [13] Z. C. Han and I. Shafrir. Lower bounds for the energy of S^1 -valued maps in perforated domains. *J. Anal. Math.*, 66:295–305, 1995.
- [14] A. Kachmar. Magnetic vortices for a Ginzburg-Landau type energy with discontinuous constraint. *ESAIM: Control, Optimisation and Calculus of Variations*, 16(3):545–580, 2009.
- [15] L. Lassoued. *Sur quelques équations aux dérivées partielles non linéaires issues de la géométrie et de la physique*. PhD thesis, Université de Paris 06 Paris, 1996.
- [16] L. Lassoued and P. Mironescu. Ginzburg-landau type energy with discontinuous constraint. *J. Anal. Math.*, 77:1–26, 1999.
- [17] P. Mironescu. Explicit bounds for solutions to a Ginzburg-Landau type equation. *Rev. Roumaine Math. Pures Appl.*, 41(3-4):263–271, 1996.
- [18] P. Mironescu. Les minimiseurs locaux pour l'équation de Ginzburg-Landau sont à symétrie radiale. *C. R. Acad. Sci. Paris Sér. I Math.*, 323:593–598, 1996.
- [19] E. Sandier and S. Serfaty. *Vortices in the Magnetic Ginzburg-Landau Model*. Birkhäuser Boston Inc., Boston, MA, 2007.
- [20] M. Sauvageot. Periodic Unfolding Method and Homogenization for the Ginzburg-Landau Equation. *arXiv:0904.1828v1*, 2009.
- [21] I. Shafrir. Remarks on solutions of $-\Delta u = (1 - |u|^2)u$ in \mathbb{R}^2 . *C. R. Acad. Sci. Paris Sér. I Math.*, 318(4):327–331, 1994.
- [22] M. Tinkham. *Introduction to Superconductivity*. McGraw-Hill, New York, 1996.