



HAL
open science

Statistical analyses of repolarisation current of a PZT film deposited on ITO electrode with different thermal treatments

Salvatore Marino, Andrei Th Ionescu, Anca-Luiza Alexe-Ionescu, Gaetano Nicastro, Giuseppe Strangi, Nicola Scaramuzza

► **To cite this version:**

Salvatore Marino, Andrei Th Ionescu, Anca-Luiza Alexe-Ionescu, Gaetano Nicastro, Giuseppe Strangi, et al.. Statistical analyses of repolarisation current of a PZT film deposited on ITO electrode with different thermal treatments. *Philosophical Magazine*, 2010, 90 (12), pp.1575-1584. 10.1080/14786430903419091 . hal-00587608

HAL Id: hal-00587608

<https://hal.science/hal-00587608>

Submitted on 21 Apr 2011

HAL is a multi-disciplinary open access archive for the deposit and dissemination of scientific research documents, whether they are published or not. The documents may come from teaching and research institutions in France or abroad, or from public or private research centers.

L'archive ouverte pluridisciplinaire **HAL**, est destinée au dépôt et à la diffusion de documents scientifiques de niveau recherche, publiés ou non, émanant des établissements d'enseignement et de recherche français ou étrangers, des laboratoires publics ou privés.



Statistical analyses of repolarisation current of a PZT film deposited on ITO electrode with different thermal treatments

Journal:	<i>Philosophical Magazine & Philosophical Magazine Letters</i>
Manuscript ID:	TPHM-09-Jun-0256.R1
Journal Selection:	Philosophical Magazine
Date Submitted by the Author:	01-Sep-2009
Complete List of Authors:	marino, salvatore; University of Calabria, department of physics Ionescu, Andrei; Universitatea din Bucuresti, Facultatea de Fizica Alexe-Ionescu, Anca-Luiza; Universitatea "Politehnica" din Bucuresti, Facultatea de Stiinte Aplicate nicastro, gaetano; University of Calabria, department of physics strangi, giuseppe; University of Calabria, department of physics Scaramuzza, Nicola; University of Calabria, department of physics
Keywords:	ferroelectrics, PZT, statistical physics
Keywords (user supplied):	



1
2
3
4 **Statistical analyses of repolarisation current of a PZT film**
5
6
7 **deposited on ITO electrode with different thermal treatments.**
8
9

10
11
12
13
14 Salvatore Marino¹, Andrei Th. Ionescu², Anca-Luiza Alexe-Ionescu³, Gaetano
15
16 Nicastro¹, Giuseppe Strangi¹ and Nicola Scaramuzza^{1,*}
17
18
19

20
21
22 1) INFM-CNR-LICRYL Laboratory-CEMIF.CAL, Department of Physics University
23
24 of Calabria, Via P. Bucci, Cubo 33B, 87036 Rende (CS) Italy
25
26

27
28 2) Facultatea de Fizica, Universitatea din Bucuresti, P.O.B MG-11, Ro-077125
29
30 Bucharest, Romania
31
32

33
34 3) Facultatea de Stiinte Aplicate, Universitatea ‘‘Politehnica’’ din Bucuresti, Splaiul
35
36 Independentei 313, Ro-060042 Bucharest, Romania
37

38
39 *) Corresponding author. Tel.: (+39) 0984-496113 Fax. (+39) 0984-494401 E-mail:
40
41 scaramuzza@fis.unical.it
42
43
44
45
46
47
48
49
50
51
52
53
54
55
56
57
58
59
60

Abstract

In the vast application fields of PZT (lead zirconium titanate) thin films, of particular interest are the interaction effects occurring at the ferroelectric - substrate interface [1,2]. Relevant for this purpose are polarity sensitive liquid crystals (LC) cells, micro and nano-electronic applications [3]. In the present work the polarization current of a PZT film ($\text{PbZr}_{0.47}\text{Ti}_{0.53}\text{O}_3$), obtained by sol-gel synthesis and deposited by spin coating on ITO (indium tin oxide) electrode, has been studied. The different behaviour showed by such a system when the support electrode is previously submitted to a thermal treatment could be attributed to the change of the electrical properties of the ITO layer. In particular, a higher negative charge in the conductive band of the ITO electrode seems to be responsible of a higher order in the ferroelectric film.

Keywords: PZT film, repolarisation current, thermal treatments, Ferroelectric properties

PACS: 77.00.00, 42.70.Mp, 77.90.+k, 03.75.Hh, 81.20.Fw

1. Introduction

PZT is a well known material for its ferroelectric properties that are suitable for a large number of applications as non-volatile ferroelectric memories, sensors [4,5] and so on [6-11]. Recently, thin films of PZT have been used to create asymmetric nematic liquid crystal cells (ANLC) in order to obtain a polarity sensitive electro-optical response. The advantage of such cells consists in controlling both ON and OFF states by an external field, consequently reducing the switching time [1]. The electro-optical response obtained with ANLCs containing PZT thin films was very interesting in terms of response time, contrast and rectifying effect. Such behaviour had been ascribed to the ferroelectric nature of the PZT film and to the interlayer phenomena occurring at the PZT-ITO interface that are responsible for a favoured orientation of the PZT nanodomains and, consequently, for the polar sensitive response of the liquid crystal layer. In this work the repolarisation current of PZT thin film obtained by sol-gel synthesis has been studied in two different cases. In the first case the PZT film has been deposited on an ITO electrode deprived of whatever thermal treatment and subsequently submitted to a heating of 600°C for 1h in order to ensure the transition to the ferroelectric perovskite phase. In the second case the ITO electrode has been previously submitted to a thermal treatment of 700°C in order to induce a change of its electric properties, then covered by the sol-gel process and eventually heated at 600°C for 1h. Interesting conclusions have been drawn from the

1
2
3 comparison between the behaviours of the repolarisation current showed by these
4
5 samples.
6
7
8
9

10 11 **2. Experimental setup**

12
13
14
15 The repolarisation currents of PZT film were investigated using the setup described
16
17 in Fig.1. The ITO substrate is connected to the output of a voltage source (Wavetek
18
19 Universal Waveform Generator model 195). The signal applied to the electrode was a
20
21 triangular wave with a 1s period. The upper electrode of cylindrical shape and 1 cm
22
23 in diameter was placed with one of its optically polished bases directly in contact to
24
25 the PZT film (the contact pressure was provided by the very weight of the copper
26
27 cube). This electrode is connected to the ground by a rather small and well known
28
29 resistor (100 Ω). The voltages drop on this resistor, measured and recorded by a high
30
31 input impedance oscilloscope (Agilent Infiniium 54832D MSO), is directly
32
33 proportional to the electric current through the PZT film. To minimize the noise, the
34
35 measuring setup (substrate, PZT film, upper electrode, and the measuring resistor)
36
37 was surrounded by a grounded Faraday cage (not shown in the figure). Another
38
39 channel of the oscilloscope was used to visualize and record the applied triangular
40
41 wave, this last one also serving to trigger the oscilloscope. For each frequency two
42
43 sets of data have been recorded, allowing representing currents and voltages versus
44
45 time. The digitized sets of data are amenable to several kind of mathematical
46
47 processing (for instance: peak area integration, smoothing, curve fitting, etc.). All the
48
49 measurements have been performed at room temperature.
50
51
52
53
54
55
56
57
58
59
60

1
2
3 We have used a rather large upper electrode because we are concerned of
4 repolarization measurements. The repolarization is controlled by the electric field in
5
6 the PZT and, therefore, we tried to create a thin planar condenser between the ITO
7
8 substrate and the polished copper surface. We are not interested in having good
9
10 ohmic contacts on top of PZT free surface, on the contrary. Actually, the ohmic
11
12 current is very small as one can easily see from Fig.2, analyzing the slopes of the
13
14 currents for the two regimes of the triangular signal (increasing and decreasing). On
15
16 the other hand, the dielectric displacement current change is quite evident at the time
17
18 instants where the two regimes of the triangular signal change the slopes. On top of
19
20 this two currents there appear the ferroelectric repolarization currents manifested as
21
22 two narrow peaks.
23
24
25
26
27
28
29
30
31
32

33 . In Fig.2 is reported the voltage-current vs time plot. The two peaks of the current
34
35 flowing through the PZT (open circle) that appear in correspondence of around +40V
36
37 and -29V of the applied voltage (black line) are due to the switch of the ferroelectric
38
39 dipole. Since the applied signal includes 200 cycles we have 400 repolarisation
40
41 switches (200 for positive polarity and 200 for negative one) that are enough to do
42
43 statistical analyses. From such measurement has been possible to carry out
44
45 information about the intensity of the repolarisation current (peak height), the voltage
46
47 value at which the repolarisation switches happens and the repolarisation switching
48
49 time (peak width measured at the base).
50
51
52
53
54
55
56
57
58
59
60

3. Results and discussion

1
2
3 The peak height variation as function of the time, measured for both polarities of the
4 applied voltage, is shown in Fig.3, while in Fig.4 are shown the same measurements
5
6 for the ITO electrode submitted to a previous thermal treatment at 700°C. Comparing
7
8 these results it is evident that in the first case a higher correlation between the
9
10 experimental data is present, in particular the peak height occurring during the
11
12 negative polarity of the applied voltage. Such difference could be attributed to a
13
14 higher order of the ferroelectric nanodomain orientation in the first case with respect
15
16 to the second case.
17
18
19
20
21
22
23
24

25 In Fig.5 are showed the histograms related to the value of the applied voltage at
26
27 which the repolarisation switches appear both for positive and negative polarity when
28
29 the ITO electrode has not been thermally treated. It is possible to notice that for
30
31 negative polarity (ITO negatively charged) the distribution of voltage values at which
32
33 the polar switch happens, within a quite narrow range, centres around 33V. On the
34
35 contrary, for positive polarity the distribution is rather wide and centres on 18V.
36
37
38
39
40
41

42 In Fig. 6 the switching time histograms of the ferroelectric repolarisation are reported
43
44 both for positive and negative polarization of the ITO not thermally treated. In this
45
46 case also it is possible to notice a remarkable difference between the opposite
47
48 polarities. In fact, for negative polarity the switching time distribution has a narrow
49
50 range cantered around 0.02s, while for positive polarity the switching time
51
52 distribution is wider and cantered on 0.04s. What can be deduced by these data is that
53
54 when the ITO electrode is negatively charged the ferroelectric repolarisation appears
55
56 in a faster and cooperative way that when the ITO electrode is positively charged.
57
58
59
60

1
2
3 The same histograms have been drawn for the sample in which the ITO electrode has
4 been previously annealed at 700°C. The histograms related to the value of the applied
5 voltage at which the repolarisation switch happens for both positive and negative
6 polarity are reported in Fig.7. A remarkable difference from the precedent case is that
7 now the required voltage to command the polar switch is higher. In fact, for positive
8 polarity, the distribution is centered on 60V while, for the negative one, around 43V,
9 moreover, the two distributions are not so different in width as the preceding ones. As
10 the ferroelectric switching time is concerned (see fig.8), in the last case we still
11 observe narrowed distribution for negative polarity respect to the positive one, but the
12 average switching time is similar, in fact both positive and negative polarity
13 distributions are centered around 0.01s.
14
15
16
17
18
19
20
21
22
23
24
25
26
27
28
29
30
31
32
33
34
35
36

37 **4. Conclusions**

38
39 In this work the switching properties of $\text{PbZr}_{0.47}\text{Ti}_{0.53}\text{O}_3$ (PZT) ferroelectric films
40 were studied. Such films were obtained by sol-gel synthesis and deposited on ITO
41 covered glass substrates by spin coating deposition and submitted to a thermal
42 treatment at 600°C for one hour to ensure the transition to the perovskite phase. The
43 analysis of the repolarisation current was effectuated on two different kinds of
44 samples: in one of them the bottom electrode was previously submitted to a thermal
45 treatment at 700°C in order to induce a structural modification of the ITO layer, while
46 in the other one the substrate was thermally untreated. From the statistical analysis
47 can be deduced that, in the case of the sample having the ITO electrode untreated, the
48
49
50
51
52
53
54
55
56
57
58
59
60

1
2
3 polar switch occurring when the ITO electrode is negatively charged appears in a
4
5 faster and cooperative way than the ITO electrode is positively charged. This
6
7 difference was less evident for the other sample, moreover, even in this last case, an
8
9 increased value of the voltage at which the ferroelectric switch happen was observed
10
11 for both polarities. Such information, together with the distribution shapes, suggests
12
13 that the structure modification induced on the ITO film by the thermal treatment is
14
15 responsible of a higher disorder of the nanodomain polarization. A possible
16
17 explanation of this behaviour should take into account the influence of the annealing
18
19 on the ITO charge carriers. In particular, we can imagine the fact that ITO/PZT
20
21 interface is not just a geometric dividing plane but it allows injection of electrons into
22
23 the PZT film. For instance, with negative polarity applied to ITO side of the sample
24
25 not only the ITO film has got an influx of electrons but also the PZT. As both
26
27 zirconium and titanium are transition metals there are d-type orbitals that can accept
28
29 extra electrons. The twin potential walls, typical for ferroelectric materials, go deeper
30
31 and the potential barrier increase (see fig.9). On the contrary, the positive potential
32
33 extracts electrons also from PZT and the barrier lowers permitting the electric dipoles
34
35 to flip over at a smaller voltage. This synergic bond mechanism [12] is consistent to
36
37 the nefelauxetic effect seen in transition metal complexes as an auxiliary contribution
38
39 to the usual ionic ligand field.
40
41
42
43
44
45
46
47
48
49
50
51
52
53

54
55 When the ITO substrate was previously treated up, its electrical properties worsen,
56
57 the permeability of electrons to PZT diminishes and the histograms cannot show
58
59 clearly the effect.
60

1
2
3
4
5
6
7
8
9
10
11
12
13
14
15
16
17
18
19
20
21
22
23
24
25
26
27
28
29
30
31
32
33
34
35
36
37
38
39
40
41
42
43
44
45
46
47
48
49
50
51
52
53
54
55
56
57
58
59
60

Acknowledgements

The authors are greatly indebted to Professor R. Bartolino for his helpful discussions.

For Peer Review Only

References

[1] E. Bruno, M.P. De Santo, M. Castriota, S. Marino, G. Strangi, E. Cazzanelli, and N. Scaramuzza: “*Morphological and electrical investigations of lead zirconium titanate thin films obtained by sol-gel synthesis on indium tin oxide electrodes*”. *Journal of Applied Physics*. **103**, (2008) p. 064103

[2] Dunn S., Whatmore R.W: “*Substrate effects on domain structures of PZT 30/70 sol-gel films via PiezoAFM*”. *Journal of the European Ceramic Society* **22** (6), (2002) p. 825

[3] S Marino, M. Castriota, G. Strangi, E. Cazzanelli, N. Scaramuzza: “*Asymmetric nematic liquid crystal cells containing lead zirconium titanate (PZT) films*”. *Journal of Applied Physics*. **102** (2007) p. 013112. Selected for Virtual Journal of Nanoscale Science & Technology July 30, 2007.

[4] Takasu, Hidemi “*The Ferroelectric Memory and its Applications*”. *Journal of Electroceramics* **4**(2), (2000) p. 327

[5] Cima Lionel, Remiens Denis: “*Ferroelectric active sensors*”. *Sensors and Actuators A: Physical* **119** (1), (2005) p. 120

1
2
3 [6] D. A. Van den Ende, P. De Almeida, Sybrand Van der Zwaag: “*Piezoelectric and*
4 *mechanical properties of novel composites of PZT and a liquid crystalline*
5 *thermosetting resin*”. *Journal of materials science* **42(15)**, (2007) p. 6417
6
7
8

9
10
11
12
13
14 [7] Wei Zhang, Di Lou, Jian Bai, Hui Ye and Guoguang Yang : “Study of a
15 deformable micro-mirror based on PZT films”. *J. Opt. A: Pure Appl. Opt.* , **9**, (2007)
16
17
18 p. 1014
19
20
21

22
23
24
25 [8] V.V. Shvartsman, N. A. Pertsev, J. M. Herrero, C. Zaldo, A.L. Kholkin: “
26 *Nonlinear local piezoelectric deformation in ferroelectric thin films studied by*
27 *scanning force microscopy*”. *Journal of Applied Physics* **97**, (2005) p. 104105
28
29
30
31

32
33
34
35 [9] M. Dawbwr, K. M. Rabe, J. F. Scott: “*Physics of thin-film ferroelectric oxides*”.
36
37
38 *Reviews of Modern Physics* **77**, (2005) p. 1083
39
40
41

42
43
44 [10] Chen Zhu, Zeng Yong, Yang Chentao, Yang Bangchao: “*Investigation the*
45 *effects of the excess Pb content and annealing conditions on the microstructure and*
46 *ferroelectric properties of PZT (52-48) films prepared by sol-gel method*”. *Applied*
47
48
49 *Surface Science* **253(3)**, (2006) p. 1500
50
51
52
53
54
55
56
57
58
59
60

1
2
3 [11] Dage liu, Chen Wang, Hongxi Zhang, Junwei Li, Liancheng Zhao, Chunli Bai.”
4
5
6 *Domain configuration and interface structure analysis of sol-gel-derived PZT*
7
8 *ferroelectric thin films*”. *Surface and Interface Analysis* **32**, (2001) p. 27
9
10

11
12
13
14 [12] J. E. Huheey, E. A. Keiter, R. L. Keiter : “*INORGANIC CHEMISTRY:*
15
16 *PRINCIPLES OF STRUCTURE AND REACTIVITY*”. 4th edition Prentice Hall, 1997
17
18
19
20 New Jersey.
21
22
23
24
25
26
27
28
29
30
31
32
33
34
35
36
37
38
39
40
41
42
43
44
45
46
47
48
49
50
51
52
53
54
55
56
57
58
59
60

Figure captions

Fig.1 Repolarization current setup . r is the measuring resistor.

Fig.2 1 s part out of the 200 s plot. The black line is the applied voltage, the open circles are the current flowing through the PZT film.

Fig.3 Peaks height as function of time (sample with the substrate previously untreated). The black squares are referred to the positive polarity, while the open circles to the negative one.

Fig.4 Peaks height as function of time (sample with the substrate previously treated). The black squares are referred to the positive polarity, while the open circles to the negative one.

Fig.5 Voltage value histograms at which the repolarization happens. Positive polarity (a), negative polarity (b). (Sample with the substrate previously untreated).

Fig.6 Switching time histograms. Positive polarity (a), negative polarity (b). (Sample with the substrate previously untreated).

1
2
3 Fig.7 Voltage value histograms at which the repolarization happen. Positive polarity
4
5
6 (a), negative polarity (b). (Sample with the substrate previously treated).
7
8
9

10
11 Fig.8 Switching time histograms. Positive polarity (a), negative polarity (b). (Sample
12
13
14 with the substrate previously treated).
15
16

17
18 Fig.9 Twin potential walls for a ferroelectric material in an ideal symmetric condition
19
20
21
22 (a) and with the electrons contribution (b).
23
24
25
26
27
28
29
30
31
32
33
34
35
36
37
38
39
40
41
42
43
44
45
46
47
48
49
50
51
52
53
54
55
56
57
58
59
60

1
2
3
4
5
6
7
8
9
10
11
12
13
14
15
16
17
18
19
20
21
22
23
24
25
26
27
28
29
30
31
32
33
34
35
36
37
38
39
40
41
42
43
44
45
46
47
48
49
50
51
52
53
54
55
56
57
58
59
60

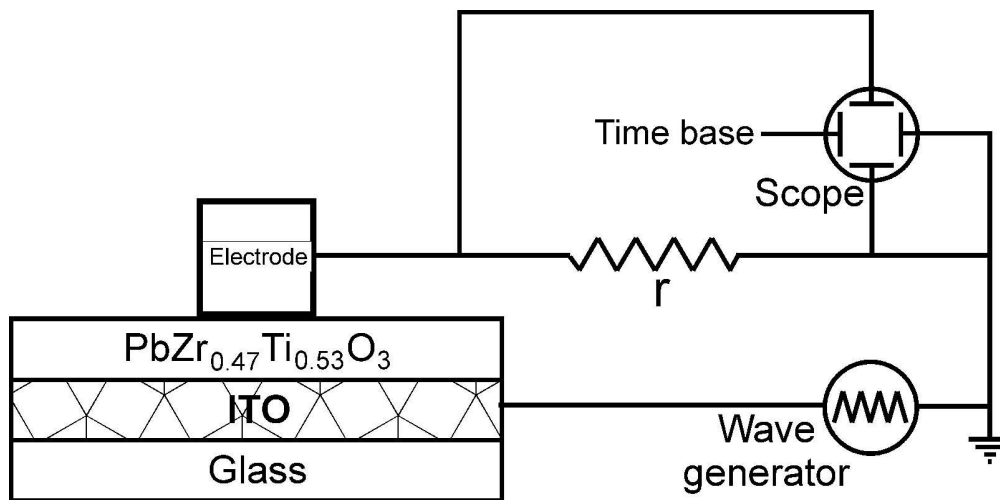

Figure 1

fig. 1
163x110mm (500 x 500 DPI)

Review Only

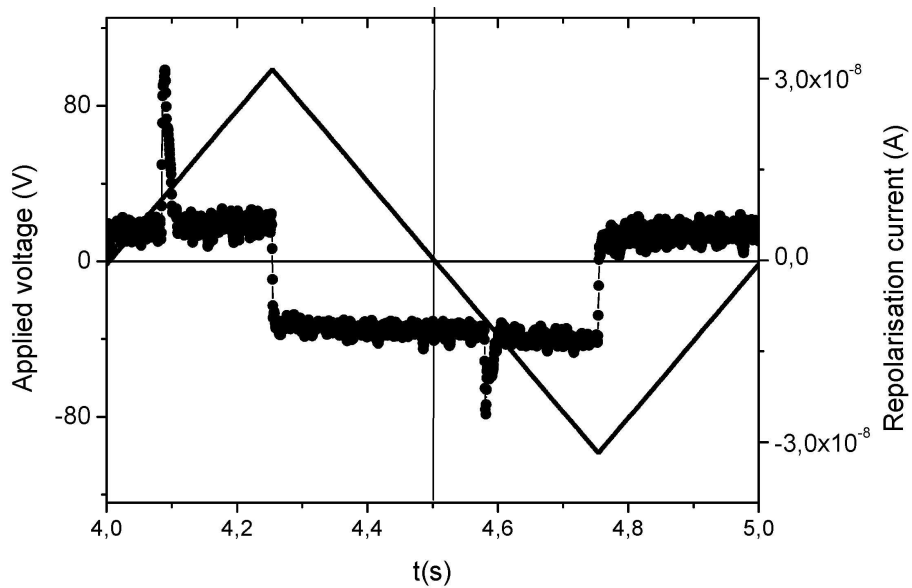

FIGURE 2

fig 2
124x93mm (500 x 500 DPI)

iew Only

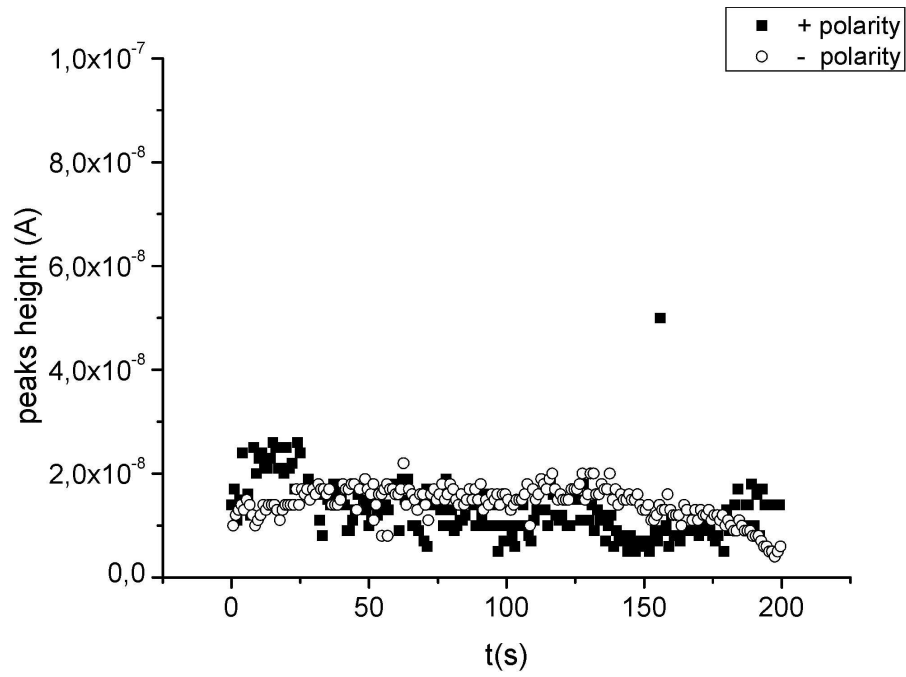

FIGURE 3

fig 3
112x96mm (500 x 500 DPI)

Only

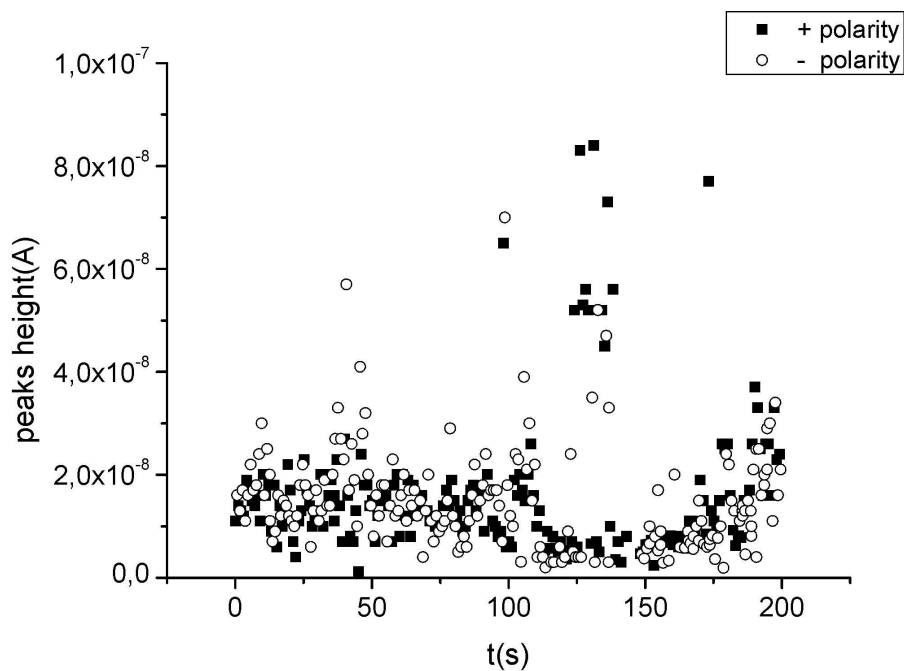
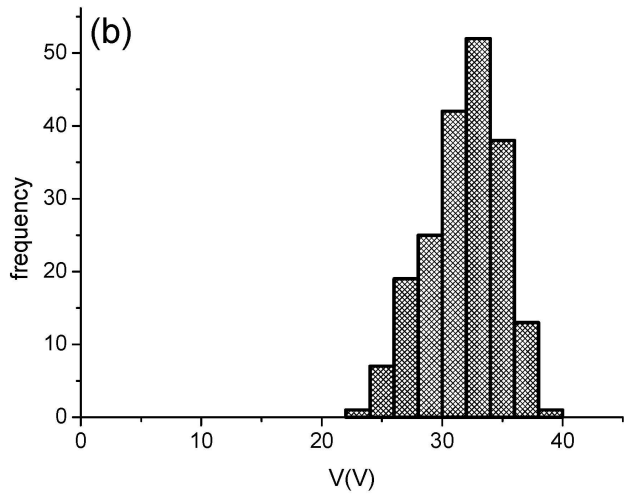
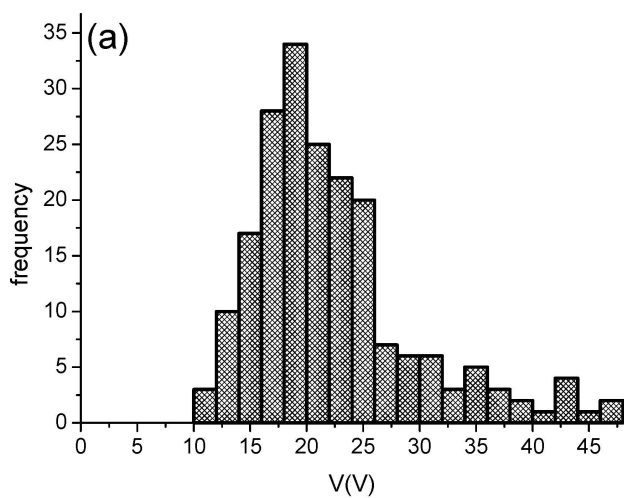

FIGURE 4

fig 4
113x96mm (500 x 500 DPI)

Only

1
2
3
4
5
6
7
8
9
10
11
12
13
14
15
16
17
18
19
20
21
22
23
24
25
26
27
28
29
30
31
32
33
34
35
36
37
38
39
40
41
42
43
44
45
46
47
48
49
50
51
52
53
54
55
56
57
58
59
60



FIGURES 5

fig 5
99x171mm (500 x 500 DPI)

1
2
3
4
5
6
7
8
9
10
11
12
13
14
15
16
17
18
19
20
21
22
23
24
25
26
27
28
29
30
31
32
33
34
35
36
37
38
39
40
41
42
43
44
45
46
47
48
49
50
51
52
53
54
55
56
57
58
59
60

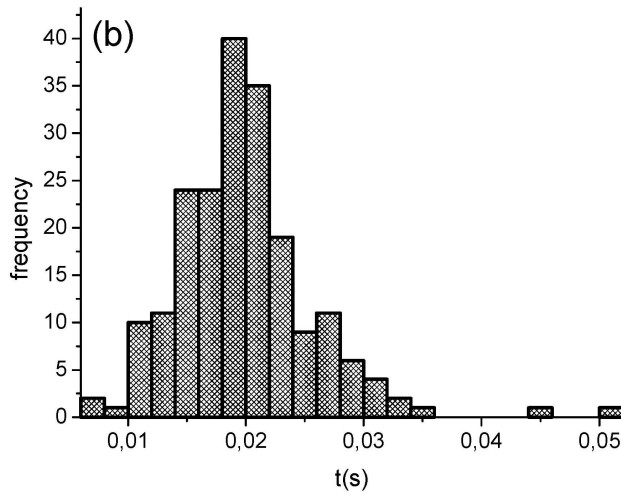
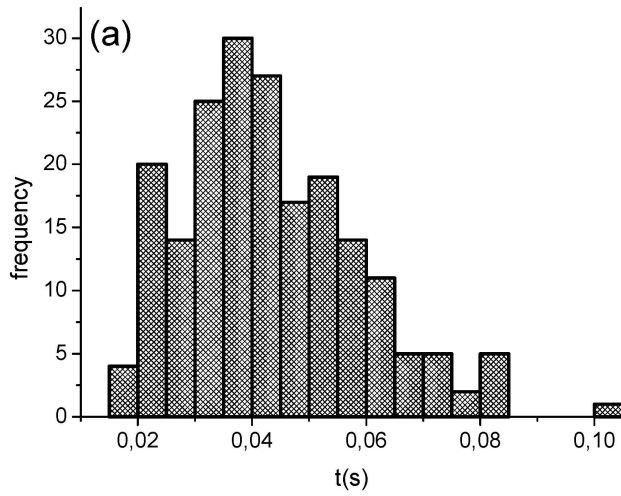

FIGURES 6

fig 6
99x171mm (500 x 500 DPI)

1
2
3
4
5
6
7
8
9
10
11
12
13
14
15
16
17
18
19
20
21
22
23
24
25
26
27
28
29
30
31
32
33
34
35
36
37
38
39
40
41
42
43
44
45
46
47
48
49
50
51
52
53
54
55
56
57
58
59
60

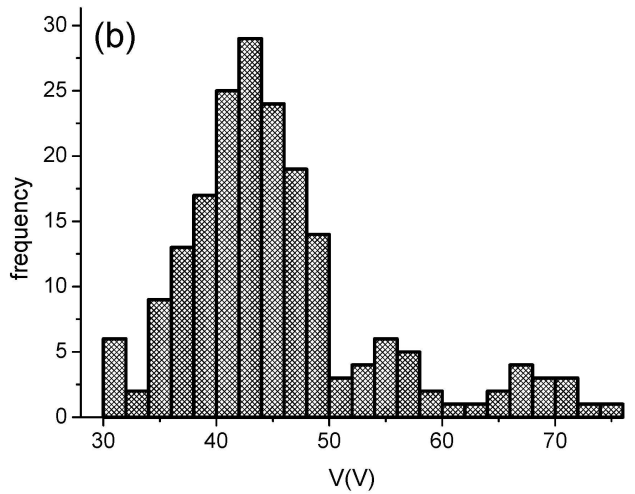
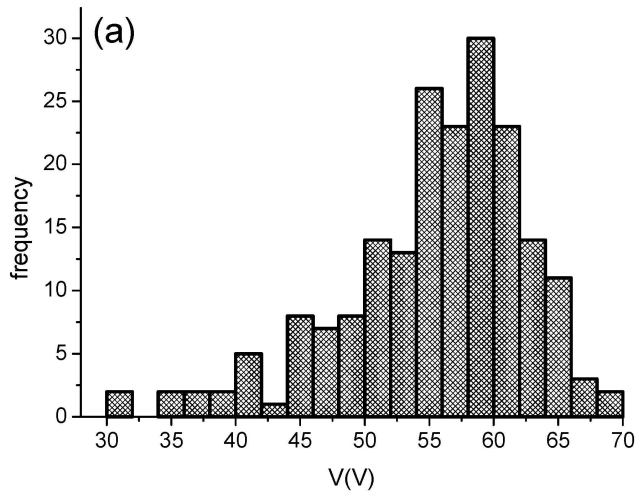

FIGURES 7

fig 7
99x171mm (500 x 500 DPI)

1
2
3
4
5
6
7
8
9
10
11
12
13
14
15
16
17
18
19
20
21
22
23
24
25
26
27
28
29
30
31
32
33
34
35
36
37
38
39
40
41
42
43
44
45
46
47
48
49
50
51
52
53
54
55
56
57
58
59
60

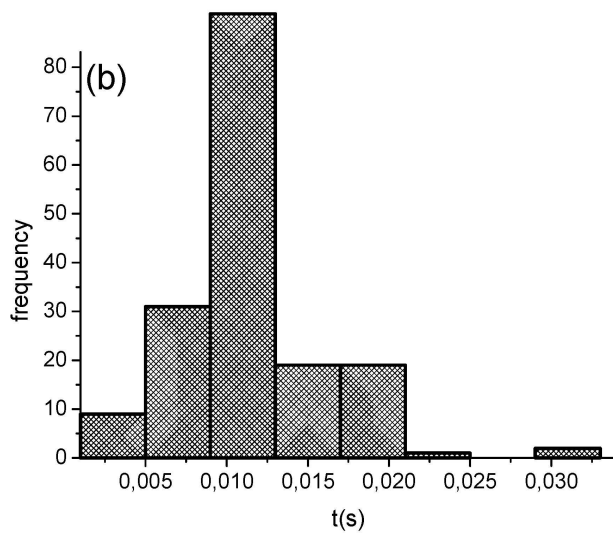
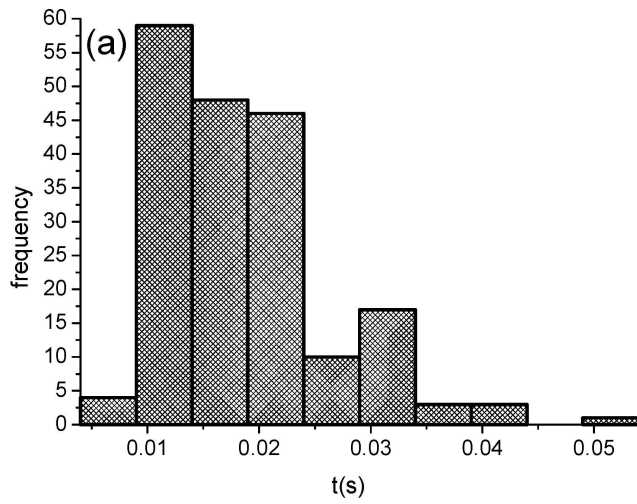

FIGURES 8

fig 8
99x172mm (500 x 500 DPI)

1
2
3
4
5
6
7
8
9
10
11
12
13
14
15
16
17
18
19
20
21
22
23
24
25
26
27
28
29
30
31
32
33
34
35
36
37
38
39
40
41
42
43
44
45
46
47
48
49
50
51
52
53
54
55
56
57
58
59
60

a) *Without electron contribution*

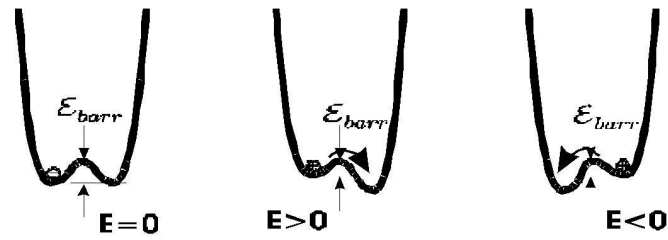

b) *With electron contribution*

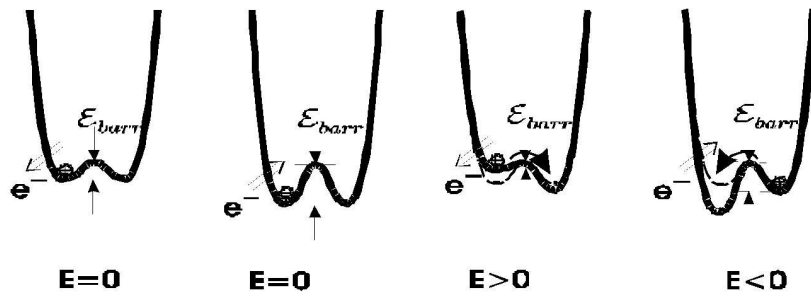

FIGURE 9

fig 9
161x134mm (500 x 500 DPI)