



**HAL**  
open science

## Application of FTIR and Raman microspectroscopy to the study of food/packaging interactions

Miguel Mauricio-Iglesias, Valérie Guillard, Nathalie Gontard, Stéphane Peyron

► **To cite this version:**

Miguel Mauricio-Iglesias, Valérie Guillard, Nathalie Gontard, Stéphane Peyron. Application of FTIR and Raman microspectroscopy to the study of food/packaging interactions. Food additives and contaminants, 2009, 26 (11), pp.1515-1523. 10.1080/02652030903148306 . hal-00573913

**HAL Id: hal-00573913**

**<https://hal.science/hal-00573913>**

Submitted on 5 Mar 2011

**HAL** is a multi-disciplinary open access archive for the deposit and dissemination of scientific research documents, whether they are published or not. The documents may come from teaching and research institutions in France or abroad, or from public or private research centers.

L'archive ouverte pluridisciplinaire **HAL**, est destinée au dépôt et à la diffusion de documents scientifiques de niveau recherche, publiés ou non, émanant des établissements d'enseignement et de recherche français ou étrangers, des laboratoires publics ou privés.



**Application of FTIR and Raman microspectroscopy to the study of food/packaging interactions**

Journal:	<i>Food Additives and Contaminants</i>
Manuscript ID:	TFAC-2009-090.R1
Manuscript Type:	Original Research Paper
Date Submitted by the Author:	12-Jun-2009
Complete List of Authors:	Mauricio-Iglesias, Miguel; University Montpellier 2, UMR 1208 IATE, UM2, CIRAD, INRA, Montpellier Supagro Guillard, Valérie; University Montpellier 2, UMR 1208 IATE, UM2, CIRAD, INRA, Montpellier Supagro Gontard, Nathalie; University Montpellier 2, UMR 1208 IATE, UM2, CIRAD, INRA, Montpellier Supagro Peyron, Stéphane; University Montpellier 2, UMR 1208 IATE, UM2, CIRAD, INRA, Montpellier Supagro
Methods/Techniques:	Chemometrics, Method validation
Additives/Contaminants:	Additives general, Packaging - migration modelling
Food Types:	Olive oil

SCHOLARONE™  
Manuscripts

1  
2  
3  
4  
5  
6  
7  
8  
9  
10  
11  
12  
13  
14  
15  
16  
17  
18  
19  
20  
21  
22  
23  
24  
25  
26  
27  
28  
29  
30  
31  
32  
33  
34  
35  
36  
37  
38  
39  
40  
41  
42  
43  
44  
45  
46  
47  
48  
49  
50  
51  
52  
53  
54  
55  
56  
57  
58  
59  
60

**Application of FTIR and Raman microspectroscopy to the study of  
food/packaging interactions**

Miguel Mauricio-Iglesias, Valérie Guillard, Nathalie Gontard, Stéphane  
Peyron\*

Joint Research Unit Agro-polymers Engineering and Emerging Technologies - UMR 1208 IATE

University Montpellier 2

CC023, Pl. E Bataillon F-34095 Montpellier cedex

E-mail : [peyron@univ-montp2.fr](mailto:peyron@univ-montp2.fr)

Tel :00 33 4 67 14 38 91

## Abstract

This study assesses the suitability of FTIR and Raman spectroscopy for potential use as analytical tools for determining the diffusivity of a migrant in a plastic packaging material, one of the key points in safety assessment of food contact materials (FCM). Despite its relative low sensitivity, FTIR based analysis supplied data for the material on desorption of an additive (Uvitex OB) and sorption of a food constituent (olive oil) in a non-destructive and “in situ” mode. These data allowed the determination of the diffusivity of Uvitex OB ( $8.0 \pm 2.5 \cdot 10^{-14} \text{ m}^2 \text{ s}^{-1}$ ) and olive oil ( $6.9 \pm 3.4 \cdot 10^{-14} \text{ m}^2 \text{ s}^{-1}$ ) in LLDPE. Raman cartography innovatively supplied the profile of additive concentration in the z-direction (thickness) of the FCM and confirmed that mass transfer in the system roughly followed a Fickian behaviour.

## Introduction

Testing for migration of food contact material additives into foods or food simulating liquid is a crucial point of safety assessment of packaging materials. However these tests, based on destructive extraction and quantification (e.g. chromatographic or spectrophotometric) procedures, are expensive and time-consuming. The directive 2002/72/CE considers the use of “generally recognised diffusion models based on experimental data [...] under certain conditions” to determine overestimated migration levels. Most of these models, used to describe migration, are based on Fick diffusion equation that involve (Crank 1980) at least two key parameters : (i) the diffusion coefficient ( $D$ ), a kinetic parameter, which measures the average ability of molecules to diffuse across the permeable phase of polymer film, and (ii) the partition coefficient (KPL) which is the ratio of additive content in the packaging material and in the foodstuff at equilibrium. Empirical and semi-empirical relationships (Begley et al. 2005; Brandsch et al. 2002; Franz 2005; Piringier 1994; Reynier et al. 1999; Reynier et al. 2001b; Vitrac et al. 2006) enable a rough evaluation of these parameters that would require otherwise a high number of experimental mass transfer tests, to be determined experimentally. An outstanding example of such relationship is the so called “Piringier equation” used to determine the diffusivity of a migrant and needs as inputs the temperature during the process, the molecular weight of the migrant and five constants, two of which depend on the type of polymer. All these parameters have been derived from a thorough analysis of reported diffusion coefficients in order that the diffusion coefficient determined should always overestimate the real value. Alternatives to the estimation of the diffusion coefficient have used the volume of the migrant (Reynier et al. 2001b) ; the Van der Waals volume, the

1 gyration radius and a shape parameter (Vitrac et al. 2006) in order to refine the predictions.  
2 Less attention has been paid though to the prediction of the partition coefficient and a  
3 commonly accepted approach has been to take it as  $K_{PL}=1$  if the migrant is soluble in the  
4 food/food simulatant or  $K_{PL}=1000$  otherwise (European Commission 2003) . A “worst case”  
5 relationship has been proposed aiming at the prediction of the partition coefficient in  
6 foodstuff depending on the partition coefficient in the n-octanol/water system ( $\log P$ ) of the  
7 migrant and two empiric parameters (Pocas et al. 2008) .

8  
9 These “predictive approaches” have been the object of some criticism whenever they are used  
10 with polymers other than polyolefins, or at high temperature or for high molecular weight  
11 migrants, at least, until more experimental data are available. Helmroth et al (2002a) found  
12 for instance that, if the Piringier model was applied to the case studied by Reynier et al  
13 (2001a) in PP at 70 °C, 50% of the predicted values underestimated the experimental ones.

14 Other authors, such as Helmroth et al (2002b; 2003) and Reynier et al (2002) , have put in  
15 turn efforts to formulate coherent methodologies to take into account the potential swelling of  
16 the polymer caused by the sorption of a solvent, as well as to determine the influence of this  
17 swelling in the release of substances into food. Of course, the success of these approaches lies  
18 also in an efficient way to obtain the kinetic data. With this scope, spectroscopic methods  
19 have been successfully used for investigation of sorption-desorption process of small  
20 molecules in polymer films (Cava et al. 2005; Cotugno et al. 2001) .

21  
22 This study aimed to explore the use of vibrational spectroscopy to study food/packaging  
23 interactions and provide data that could be used to determine the mass transfer parameters of  
24 the system. Despite its high detection limit, FT-IR based analysis supplied a very useful  
25 experimental tool to monitor transfer properties of polymer films in a non-destructive mode.  
26 Other methods, such as micro-UV(Reynier et al. 2002) , provide information about the  
27 migration process taking place inside the polymers with a micrometer-scale spatial resolution.  
28 Likewise, Raman micro-spectroscopy has been used to study to determine concentration  
29 profile of low molecular weight compounds in the polymers at a micrometric scale (Sammon  
30 et al. 1999) . This method could be considered as a promising complementary method of  
31 micro UV (active molecules in UV are not necessarily active in Raman and *vice versa*), to  
32 investigate in a versatile, quick and non-destructive way, the distribution profile of additives  
33 in plastic material. With confocal collection optics, the method should allow to follow the  
34 migration process as a function of both time and space and, consequently, to plot additive

1 concentration profile in the depth of polymer sample in order to easily gather mass transfer  
 2 parameters. To the best of our knowledge, this has never been done up to now, partly because  
 3 both methods are not considered as sensitive enough to study migration, but, as it will be seen  
 4 subsequently, they can be successfully used to characterize mass transfer in model systems.

5  
 6 Two different approaches were used to determine the diffusivity of a migrant in a plastic  
 7 packaging material by two vibrational spectroscopy methods i.e. FT-IR and Raman  
 8 spectroscopy. Uvitex OB, an optical brightener and UV stabiliser approved for Food Contact  
 9 Materials, was selected as model migrant to spike LLDPE films. The samples were submitted  
 10 to migration test according to EC directives and analysed by FT-IR and Raman  
 11 microspectroscopy during immersion in the worst case food simulating liquid *i.e.* the olive  
 12 oil, with the objective to determine the diffusion coefficient on the basis of a resolution of  
 13 Fick's law.

### 14 15 **Theory**

16 The internal diffusion of migrant in the packaging is:

$$17 \quad t > 0, -L < x < L, \quad \frac{\partial C}{\partial t} = \frac{\partial}{\partial x} \left( D \frac{\partial C}{\partial x} \right) \quad (1)$$

18 where  $x$  is the distance (m),  $C$  the packaging concentration in migrant (kg additive/kg of  
 19 polymer) and  $D$  the migrant diffusivity in the packaging ( $\text{m}^2\text{s}^{-1}$ ). If  $D$  is independent of the  
 20 concentration of the diffusing substances (at least at the concentration range found in the  
 21 experiment), the system is said to follow Fickian kinetics.

22 Equation (1) was solved with the initial and boundary conditions that apply for this case  
 23 study *i.e.*:

$$24 \quad t = 0, -L < x < L, \quad C = C_{in} \quad (2)$$

$$25 \quad t > 0, x = +L, \quad C = C_{L,\infty} \quad (3)$$

$$26 \quad t > 0, x = 0, \quad \frac{\partial C}{\partial x} = 0 \quad (4)$$

27  
 28 where  $C_{in}$  is the concentration initially present in the polymer,  $C_{L,\infty}$  is the concentration of the  
 29 diffusing substance on the surface of the polymer required to maintain equilibrium with the  
 30 concentration of this substance in the liquid at time  $t$ .

1 In some cases, the diffusivity  $D$  is dependent on the concentration of the diffusing substance  
 2 as it is the case of substances that alter the structure of the polymer. According to the free  
 3 volume theory,  $D$  is proportional to the exponential of the free volume within the polymer  
 4 (Duda and Zielinsky 1996) . Based on this assumption, several authors (Helmroth et al. 2003;  
 5 Reynier et al. 2002) have successfully modelled the dependence of  $D$  as:

$$6 \quad D(x,t) = D_0 \exp\left(\gamma \frac{c(x,t)}{c_{MAX}}\right) \quad (5)$$

7 where  $D_0$  is the zero concentration diffusivity and  $\gamma$  is a proportional factor. Of course, if  $\gamma$  is  
 8 equal to zero, diffusivity is a constant and kinetics follows the Fickian model. Taking into  
 9 account the potential dependency of diffusivity and concentration, several scenarios are  
 10 possible; case i) diffusivity is independent of Uvitex OB and olive oil (Fickian kinetics); case  
 11 ii) diffusivity depends only on Uvitex OB concentration; case iii) diffusivity depends only on  
 12 olive oil concentration; and case iv) diffusivity depends on both Uvitex OB and olive oil.

### 14 *Solving procedure*

15 If the sorption/desorption phenomena follow Fickian kinetics, the system of equations (1-4),  
 16 can be solved analytically and the evolution of concentration with time is given by  
 17 Crank(1980) :

$$18 \quad \frac{C(x,t) - C_{in}}{C_{L,\infty} - C_{in}} = 1 - \frac{4}{\pi} \sum_{n=0}^{\infty} \frac{(-1)^n}{2n+1} \exp\left[-\frac{(2n+1)^2 \pi^2}{4L^2} D.t\right] \cos\left[\frac{(2n+1)\pi x}{2L}\right] \quad (6)$$

$$19 \quad \frac{\bar{C}_t - C_{in}}{C_{L,\infty} - C_{in}} = 1 - \frac{8}{\pi^2} \sum_{n=0}^{\infty} \frac{1}{(2n+1)^2} \exp\left[-\frac{(2n+1)^2 \pi^2}{4L^2} D.t\right] \quad (7)$$

20 where  $C$  is the concentration in diffusing substance in  $x$  at time  $t$  and  $\bar{C}_t$  is the average  
 21 concentration in diffusing substance in the packaging at time  $t$ .

22 Nevertheless, if Fickian kinetics cannot be assumed e.g.  $D$  varies with the concentration of  
 23 migrant and/or with olive oil entering the packaging, there is no analytical solution to  
 24 Equation (1). Considering an exponential relationship between concentration and diffusivity  
 25 (Equation (5)), Equation 1 was solved using a Crank-Nicholson-like scheme i.e. a central  
 26 difference in space and a trapezoidal rule in time.

## 1 **Materials & Methods**

### 2 ***Chemicals***

3 Uvitex OB and solvents were of reagent grade or highest purity available. 2,5-Bis-(5-tert.-  
4 butyl-benzoxazol-2-yl)-thiophen (Uvitex OB, 430.6 g mol<sup>-1</sup>) was purchased from Fluka..  
5 Methanol (99.9%), tetrahydrofuran (THF, 98%) and toluene (99%) were purchased from  
6 Carlo Erba. LLDPE pellets were purchase from Sigma Aldrich. Olive oil was purchased in a  
7 local supermarket.

### 9 ***Films fabrication.***

10 LLDPE pellets were mixed with additives at 140°C (50 rpm) during 5 min in a twin counter  
11 rotating internal mixer (Rheomix 600 Haake, Germany) connected to a control unit  
12 (Rheocord 9000 Haake, Germany). Then, the dough material obtained after mixing was then  
13 thermoformed (hot press) at 100 bar during 10 min at 140°C. Films preparation was kindly  
14 carried out by IMCB (Naples, Italy). A nominal concentration of 0.4% w/w was used, higher  
15 than found in commercial polymers. The thickness obtained was 656 ± 64 µm (measured by a  
16 micrometer, Braive Instruments, Chécy, France).

### 18 ***Migration test***

19 Following the conditions set in directives 85/572/EEC and 2002/72/EC, 3.5 cm<sup>2</sup> film samples  
20 were fully immersed in 6 ml olive oil at 40°C. Before each measurement the sample were  
21 removed from the olive oil and thoroughly wiped in a reproducible way with a precision  
22 wipe. The weight was recorded to determine the uptake of olive oil. FTIR measurements were  
23 done after 3, 6, 10, 15 and 26 days of storage. Raman measurements were done after 4h, 1 and  
24 3 days of storage.

### 26 ***Additives extraction***

27 3.5 cm<sup>2</sup> samples were dissolved in 3 ml of toluene and reprecipitated in 15 ml of methanol then  
28 filtered with 2 x 5 ml of methanol. The extract was evaporated to dryness in a rotary  
29 evaporator (Heidolph VV 2000, Germany) and dissolved again in 10.0 ml of THF.

### 31 ***UV spectroscopy analysis***

32 The quantity of additive in THF extract was determined using a Cary 100 UV-visible  
33 spectrometer (Varian) at λ = 374 nm at controlled temperature of 25 ± 2 °C. Two  
34 measurements were performed for each sample.



### ***FTIR measurement***

LLDPE film samples were analyzed by means in transmission FTIR. Spectra were recorded using a Nexus 5700 spectrometer (ThermoElectron Corp.) equipped with HeNe beam splitter and a cooled MCT detector. Spectral data were accumulated from 128 scans with a resolution of  $4\text{ cm}^{-1}$  in the range  $800\text{-}4000\text{ cm}^{-1}$ . Three samples were employed for the measure and three spectra were recorded for each sample

All spectra pre-treatments were performed using Omnic v7.3 and TQ Analyst v7.3 softwares (ThermoElectron) Processing included: (1) a multipoint linear baseline correction, (2) a normalization according to the area of the LLDPE doublet ( $1369\text{-}1378\text{ cm}^{-1}$ ) due to the  $\text{CH}_3$  symmetric deformation vibration.

### ***Raman spectroscopy***

Uvitex concentration profiles in the LLDPE were determined as follow. Thin slices of LLDPE were prepared using a razor blade and stuck on a microscope slide (Figure 1).

Raman spectra were recorded between  $95$  and  $3500\text{ cm}^{-1}$  Raman shift using a confocal Raman microspectrometer Almega (Thermo-Electron) with the following configuration: excitation laser He-Ne  $\lambda_0 = 633\text{ nm}$ , grating  $500\text{ grooves/mm}$ , pinhole  $25\text{ }\mu\text{m}$ , objective  $\times 50$ . The collection time was about  $50\text{ sec}$ . Measurements were carried out in the depth sample with a pitch of  $2\text{ }\mu\text{m}$  from the sample center to the interface. Samples were exposed to photobleaching for  $15\text{ s}$  from the third day of test in order to avoid fluorescence caused by olive oil sorption. Since the concentration in the samples was too heterogeneous as it will be explained later, a measure of initial concentration was carried out by FTIR to all the samples studied.

All spectra pre-treatments were performed with Omnic v7.1 (Thermo-Electron). Processing included: (i) a multipoint linear baseline correction, (ii) normalization according to the area of the LLDPE specific band at  $1129\text{ cm}^{-1}$  representing the symmetric C-C stretching of all-*trans* PE chains. The relative content of Uvitex OB was assessed using the area of the specific doublet ( $1569\text{-}1614\text{ cm}^{-1}$ ) assigned to the aromatic C=C and C=N bands.

### ***Statistics***

1 The test of normality of Anderson-Darling (Trujillo-Ortiz et al. 2007) was used to analyse the  
2 homogeneity of the samples.

3 The root mean square error (RMSE) was used to estimate the quality of model fitting and was  
4 calculated as follows:

$$RMSE = \sqrt{\frac{(y_{\text{exp}} - y)^2}{(N - p)}} \quad (8)$$

5 where  $y_{\text{exp}}$  and  $y$  are respectively the experimental and predicted additive content values (kg  
6 of additive/kg of polymer),  $N$  is the number of additive content measurements and  $p$  is the  
7 number of identified parameters.

8 For each experiment, the average of 95% confidence interval of all the replicates represented  
9 the experimental error ( $\bar{E}$  in kg of additive/kg of polymer). For estimating the good fitting or  
10 not of the model, the RMSE and the  $\bar{E}$  were compared. A fitting was considered as good  
11 when  $RMSE \leq \bar{E}$ .

### 12 *Estimation of diffusivity*

13 The additive diffusivity was identified from experimental data by minimizing the root mean  
14 square error (RMSE) between experimental and predicted data (Equations (6) and (7)) and by  
15 using an optimization method (Levenberg-Marquardt algorithm, *optimization* routine  
16 predefine from Matlab software). A Monte Carlo sampling was applied to the input  
17 parameters (concentration, thickness and time) in order to determine the 95% confidence  
18 intervals as explained elsewhere (Hessler 1997; Press et al. 1989).

## 19 **Results**

20 After determining the additive distribution in the film samples, the quantification of Uvitex  
21 OB and olive oil content was investigated by FTIR throughout the test and used to determine  
22 the migration level of Uvitex OB as well as the diffusivity of both olive oil and Uvitex OB.  
23 Likewise, Raman measurements were used to determine diffusivity of Uvitex OB in LLDPE  
24 and both results were compared

### 25 *Uvitex OB distribution in LLDPE samples*

26 The Uvitex OB concentration in LLDPE used for the tests turned out not to be  
27 homogeneously distributed as determined by the test of normality of Anderson-Darling

1 (Trujillo-Ortiz et al. 2007) (the result was positive for an  $\alpha = 0.05$ ). The distribution of the  
2 additive (Figure 2) proved to be heterogeneous and normally distributed. The test of  
3 normality was applied to 186 samples and gave as a result a mean concentration of 0.41%  
4 w/w with a standard deviation of 0.051%. So the coefficient of variation, i.e. the quotient  
5 between the standard deviation and the mean was of 12.2%. As an illustration, this means that  
6 the 95% of the samples will have concentrations comprised between 0.31% and 0.50% w/w.  
7 For a migration experiment, the additive content is usually assumed to be homogeneous in  
8 migration tests for all the samples. However, the distribution of additive among the samples  
9 hinders the use of standard destructive methods since the variations on the initial  
10 concentration of each sample could be comparable to the variations of concentrations  
11 throughout the test. This obstacle can be overcome either by increasing the number of  
12 samples for destructive methods (highly time consuming), either using a non-destructive  
13 method such as FTIR, that can thoroughly guarantee the traceability of the samples  
14 throughout the test and then, avoid the uncertainty caused by the variations in the initial  
15 content of additive. Finally, it must be borne in mind that the lack of sensitivity of the  
16 methods implied using a high concentration (0.4% w/w of Uvitex OB). If the additive is not  
17 completely soluble in LLDPE at that concentration, it would be the responsible for the  
18 heterogeneous distribution of the additive.

### 20 ***Quantification of Uvitex OB and olive oil in LLDPE***

21 Simultaneous desorption of Uvitex OB and sorption of olive oil were investigated using  
22 FTIR. A detailed study of the additive fingerprint allowed to determine the most suitable  
23 bands for the analysis. Considering the blend LLDPE spectrum, Uvitex OB fingerprint  
24 exhibited some specific bands which could be employed to detect its occurrence in the films.  
25 Regarding the higher absorbance value, Uvitex OB occurrence was specifically detected at  
26  $1579\text{ cm}^{-1}$  assigned to the aromatic C=C stretching band (Figure 3). In turn, olive oil sorption  
27 into LLDPE was followed in the ester stretching band at  $1750\text{ cm}^{-1}$ .

29 With LLDPE samples including variable contents in Uvitex OB, a Partial Least Square (PLS)  
30 model was calibrated on the basis of the intensity ratio  $1579/1378\text{ cm}^{-1}$ . The regression  
31 produced a linear relationship ( $R^2 = 0.96$ , RMSE= 0.034% w/w) between spectral data and  
32 additives concentration measured by UV spectroscopy analysis.

1 Subsequently, the same procedure was carried out to relate spectral data and olive oil content.  
2 The uptake of olive oil was considered to be equal to the increase of mass of the sample less  
3 the quantity of Uvitex desorbed (quantified with FTIR measurements). The data fitted  
4 satisfactorily the model ( $R^2 = 0.99$ , RMSE= 0.040% w/w).

#### 6 *Determination of the diffusivities of Uvitex OB and olive oil in LLDPE with FTIR*

7 The migration of Uvitex OB in olive oil was followed during 26 days by FTIR. Spectra were  
8 normalized on a specific LLDPE doublet (1369-1378  $\text{cm}^{-1}$ ) and the decrease in absorbance at  
9 1579  $\text{cm}^{-1}$  showed the desorption of Uvitex OB from LLDPE film from an initial content of  
10 0.4% w/w to a value below the detection limit after 26 days. Likewise, the uptake of olive oil  
11 in the sample was obtained as a function of time and a plateau was determined at  $1.3 \pm 0.1\%$   
12 w/w of olive oil. From data obtained from FTIR experiments, desorption curves of Uvitex OB  
13 from LLDPE in olive oil were obtained by plotting the relative concentration as a function of  
14 time (Figure 4).

15  
16 The determination of diffusivity values for Uvitex desorption and olive oil sorption in the  
17 LLDPE film was evaluated during migration kinetics in olive oil using equation (7). For  
18 Uvitex OB, the resulting diffusivity value was of  $8.0 \pm 2.5 \cdot 10^{-14} \text{ m}^2 \text{ s}^{-1}$  and the RMSE of 0.02%  
19 w/w, lower than the experimental error evaluated as a 0.04% w/w. This results was in  
20 agreement with experimental data previously reported since a value of diffusivity of  $5 \cdot 10^{-14}$   
21  $\text{m}^2 \text{ s}^{-1}$  was found by Dole et al (2006) (same temperature but in LDPE). For olive oil the  
22 diffusivity value was  $6.9 \pm 3.4 \cdot 10^{-14} \text{ m}^2 \text{ s}^{-1}$  and the RMSE 0.07 % w/w, slightly larger than the  
23 experimental error estimated as 0.04% w/w but remaining still in an acceptable range. The use  
24 of non-destructive measurement by FTIR allowed to fully trace the content of Uvitex OB of  
25 the sample all throughout the experiment and thus, to determine an accurate value of  
26 diffusivity which would not be feasible with other common analytical procedures with a  
27 comparable accuracy. Furthermore, FTIR also provided data on the uptake of olive oil in the  
28 sample that led to the determination of its diffusivity in LLDPE. Advantages of FTIR to carry  
29 migration tests out include, besides the possibility to obtain non-destructive measurements,  
30 supplying additional information of the polymer evolution (e.g. oxidation) and of a number of  
31 substances that could be sorbed during the test. Its main disadvantage lies in its lack of  
32 sensitivity compared to other analytical methods. When dealing with complex migration  
33 behaviour, as for instance, when diffusivity can no longer be considered as a constant (non-

Fickian kinetics), a large number of data are required that are difficult to obtain by FTIR or other similar method that provided the average concentration of a sample. Raman microspectroscopy was explored as a promising tool to obtain a further insight of mass transfer in the polymer for it gives access to more information on migration kinetics such as concentration profiles of Uvitex OB in the depth of the LLDPE sample as a function of time.

### ***Raman Measurements***

Concentration profiles were determined after contact times of 4h, one day and three days, shorter than those required by FTIR, proving to be an efficient method for the determination of diffusivity. For each contact time, Raman intensity profile obtained was compared to the total mass of Uvitex remaining in the film determined by FTIR (Figure 5). The Raman profile allowed the determination of the total content of Uvitex OB in the film according to equation (9)

$$\text{mass of Uvitex} = \rho S \int_{-L}^{+L} C(z) dz \quad (9)$$

where  $\rho$  stands for the bulk density of the polymer ( $920 \text{ kg m}^{-3}$  for LLDPE),  $S$  for the surface and  $C$  for the concentration. A linear regression was used to successfully correlate ( $R^2=0.96$ ) the data supplied by FTIR and the band assigned to Uvitex ( $1569\text{-}1614 \text{ cm}^{-1}$ ) normalized with the area ratio of the LLDPE specific band ( $1129 \text{ cm}^{-1}$ ).

### ***Determination of the diffusivity of Uvitex OB in LLDPE***

The three concentration profiles obtained were treated altogether and used to determine whether diffusivity of Uvitex OB was independent of its own and/or olive oil concentration. Four scenarios were considered (table 1): i) diffusivity is independent of Uvitex OB and olive oil (Fickian kinetics), ii) diffusivity depends only on Uvitex OB concentration, iii) diffusivity depends only on olive oil concentration and iv) diffusivity depends on both Uvitex OB and olive oil. The first case was solved using equation (6) and the last three using a modification of the Crank Nicolson method as stated in the Materials and Methods section. For cases iii) and iv) olive oil was considered to modify the diffusivity of Uvitex OB in LLDPE but not its own diffusivity. Thus, the constant value of diffusivity obtained with the FTIR analysis using and equation (6) and, the concentration of olive oil in LLDPE samples was estimated as a function of space and time. These values of concentration were then used to determine the potential dependency of Uvitex OB diffusivity on olive oil content. On the basis of the RMSE

1  
2  
3 1 comparison (Table 1), it was verified that the increase of factors in the model did not  
4 significantly increase the accuracy of the predictions. Figure 6 shows the experimental data of  
5 concentration profiles of Uvitex OB in LLDPE as well as those predicted with the diffusivity  
6 value obtained for scenario i), i.e. Fickian kinetics and how they are well correlated if  
7 compared to previous works in which the concentration profile is fitted (Helmroth et al. 2003;  
8 Reynier et al. 2002) . Therefore, scenario i) was accepted as the most likely and simplest, i.e.  
9 Fickian kinetics and a diffusivity independent of the concentration of either olive oil or  
10 Uvitex OB, at least in the concentration range found during the experiments, which confirms  
11 the results obtained by FTIR. According to Raman measurements a value of diffusivity was  
12 obtained of  $(14.6 \pm 2.5 \cdot 10^{-14} \text{ m}^2 \text{ s}^{-1})$ . Although significantly different for  $p=0.05$ , it lies in the  
13 same range as the one obtained by FTIR, and indeed both values were no longer different  
14 when considering a value of  $p=0.025$ . It is a quite meaningful result given the high deviations  
15 that can be found in the determination of diffusivity. For example, Dole et al. (2006) reported  
16 differences up to 350% for the diffusivity of Uvitex OB in PP measured with the same  
17 method.

18  
19 Hence, the investigation of diffusivity of a model molecule by Raman spectroscopy allowed  
20 the assessment of several complex phenomena that influence migration in an integrated  
21 approach. Raman microspectroscopy was used to provide large amount of data on the inside  
22 of the polymer that can be used to assess diffusivity variations. Even though it is theoretically  
23 possible to consider a variable diffusivity with global measurements as those performed by  
24 FTIR or standard extraction/quantification methods, in reality it is often unfeasible since a  
25 high number of experimental values are needed in practice to fit several parameters correctly  
26 especially for non-linear models (Hessler 1997). In most cases, FTIR sensitivity is too low to  
27 provide such a number of values from a desorption experiment and other conventional  
28 methods turn out to be far too time-consuming.

29  
30 It must be pointed out that the concentration at  $15 \mu\text{m}$  of the interface was always  
31 underestimated by the predicted values (Figure 6) what could mean that there is a non-  
32 negligible mass transfer resistance in the interface. This hypothesis is attractive and it would  
33 make the Raman approach even more valuable since it would easily reveal whether mass  
transfer resistance at the interface can be neglected. Unfortunately, the measurements of  
points located so close to the interface are less reliable than those in the inside (Everall 2008).

1  
2  
3 1 Extreme care must be taken if assumptions are made based exclusively on the measurements  
4  
5 2 located the closest to the interface.  
6  
7 3

8  
9 4 Regarding the effect of olive oil in desorption, it is sometimes widely accepted that, since the  
10 5 polarity of triglycerides in olive oil is similar to that of polyolefins, olive oil is easily absorbed  
11 6 and greatly influences the diffusivity in polyolefins. This has been tested for several low  
12 7 molecular solvents (Helmroth et al. 2003) but very few results in the literature support this  
13 8 hypothesis for olive oil. Several authors found that olive oil did not modify the release of  
14 9 medium molecular weight additives from polyolefins (Goydan et al. 1990; Helmroth et al.  
15 10 2002b; O'Brien et al. 1999) In contrast, Reynier et al.(2002) suggested an exponential  
16 11 dependency of diffusivity with the triglyceride content, but they used glyceril tripelargonate  
17 12 instead of olive oil, which could explain this discrepancy. Our results underpin the hypothesis  
18 13 that olive oil does not modify the diffusivity of a medium molecular weight ( $431 \text{ g mol}^{-1}$ )  
19 14 additive in polyolefins. In addition, it must be borne in mind that the olive oil uptake is only  
20 15 of a 1-2% w/w in polyolefins (1.3% w/w in our study) whereas it is commonly stated that, as  
21 16 a rule of thumb, 15% w/w of solvent absorption accounts for an increase of ten folds of  
22 17 diffusivity (Helmroth et al. 2002b) . With this in mind, olive oil sorption as observed in this  
23 18 study is too low to carry out an important modification of diffusivity.  
24  
25  
26  
27  
28  
29  
30  
31  
32  
33  
34  
35  
36  
37  
38

### 39 20 **Conclusion**

40 21 With the scope of improving the analysis of food/packaging interactions, the application of  
41 22 two types of vibrational spectroscopy (FTIR and Raman) was presented. The aim of the  
42 23 approach was not to quantify migration levels but to characterize mass transfer parameters in  
43 24 the system. Both, FTIR and Raman, were successfully used to determine diffusivity values of  
44 25 Uvitex OB that could be further use to simulate its release, according to legislation. With the  
45 26 example developed here, each of the methods (FTIR and Raman) proved to be a very efficient  
46 27 mean to access to the parameters necessary for predicting the migration in realistic conditions.  
47 28 FTIR was used to know the average concentration in the LLDPE sample as a function of time.  
48 29 Raman microspectroscopy gave the possibility to gather the concentration profile in the depth  
49 30 of the sample and use these data to perform a complex analysis of the factors that could  
50 31 influence the diffusion coefficient, e.g. it was demonstrated that olive oil sorption did not  
51 32 modify the diffusivity of Uvitex OB in LLDPE. Regarding the experimental set up, a non-  
52 33 negligible time gain could be achieved.  
53  
54  
55  
56  
57  
58  
59  
60

34

## Acknowledgements

This study has been carried out with financial support from the Commission of the European Communities, Framework 6, Priority 5, "Food Quality and Safety", Integrated Project Novel Q FP6-CT-2006-015710. Authors would like to acknowledge Prof. Salvatore Iannace and co-workers from IMCB (Naples, Italy) for the preparation of the films used in this study.

## References

- Begley, T.; Castle, L.; Feigenbaum, A.; Franz, R.; Hinrichs, K.; Lickly, T.; Mercea, P.; Milana, M.; O'Brien, A.; Rebre, S.; Rijk, R.; Piringer, O. 2005. Evaluation of migration models that might be used in support of regulations for food-contact plastics. *Food Additives and Contaminants* 22, 73-90.
- Brandsch, J.; Mercea, P.; Ruter, M.; Tosa, V.; Piringer, O. 2002. Migration modelling as a tool for quality assurance of food packaging. *Food Additives and Contaminants* 19, 29-41.
- Cava, D.; Catala, R.; Gavara, R.; Lagaron, J. M. 2005. Testing limonene diffusion through food contact polyethylene by FT-IR spectroscopy: Film thickness, permeant concentration and outer medium effects. *Polymer Testing* 24, 483-489.
- Cotugno, S.; Larobina, D.; Mensitieri, G.; Musto, P.; Ragosta, G. 2001. A novel spectroscopic approach to investigate transport processes in polymers: the case of water-epoxy system. *Polymer* 42, 6431-6438.
- Crank, J. 1980. *The Mathematics of Diffusion*, 1st ed.; USA, Oxford University Press.
- Dole, P.; Feigenbaum, A. E.; De la Cruz, C.; Pastorelli, S.; Paseiro, P.; Hankemeier, T.; Voulzatis, Y.; Aucejo, S.; Saillard, P.; Papaspyrides, C. 2006. Typical diffusion behaviour in packaging polymers - application to functional barriers. *Food Additives and Contaminants* 23, 202-211.
- Duda, J.; Zielinsky, J. Free volume theory. 1996 *Diffusion in polymers* CRC P. Neogi, Ed.; Chapter 3 Free volume theory. pp 143-173.
- European, C. 2003. *A Practical Guide for Users of European Directives*, Unit "Chemical and physical risks; surveillance" of the Health & Consumer Protection Directorate-General of the European Commission,
- Everall, N. 2008. The influence of out-of-focus sample regions on the surface specificity of confocal Raman microscopy. *Applied Spectroscopy* 62, 591-598.
- Franz, R. 2005. Migration modelling from food-contact plastics into foodstuffs as a new tool for consumer exposure estimation. *Food Additives and Contaminants* 22, 920-937.



- 1  
2  
3 1 Goydan, R.; Schwoppe, A. D.; Reid, R. C.; Cramer, G. 1990. High-Temperature Migration of  
4 Antioxidants from Polyolefins. *Food Additives and Contaminants* 7, 323-337.  
5  
6 2  
7 3 Helmroth, E.; Rijk, R.; Dekker, M.; Jongen, W. 2002a. Predictive modelling of migration  
8 from packaging materials into food products for regulatory purposes. *Trends in Food*  
9 *Science & Technology* 13, 102-+.  
10  
11 5  
12 6 Helmroth, I. E.; Dekker, M.; Hankemeier, T. 2002b. Influence of solvent absorption on the  
13 migration of Irganox 1076 from LDPE. *Food Additives and Contaminants* 19, 176-  
14 183.  
15  
16 8  
17 9 Helmroth, I. E.; Dekker, M.; Hankemeier, T. 2003. Additive diffusion from LDPE slabs into  
18 contacting solvents as a function of solvent absorption. *Journal of Applied Polymer*  
19 *Science* 90, 1609-1617.  
20  
21 11  
22 12 Hessler, J. P. 1997. The use of Monte Carlo simulations to evaluate kinetic data and analytic  
23 approximations. *International Journal of Chemical Kinetics* 29, 803-817.  
24  
25 13  
26 14 O'Brien, A.; Goodson, A.; Cooper, I. 1999. Polymer additive migration to foods - a direct  
27 comparison of experimental data and values calculated from migration models for  
28 high density polyethylene (HDPE). *Food Additives and Contaminants* 16, 367-380.  
29  
30 16  
31 17 Piringer, O. G. 1994. Evaluation of Plastics for Food-Packaging. *Food Additives and*  
32 *Contaminants* 11, 221-230.  
33  
34 18  
35 19 Pocas, M. F.; Oliveira, J. C.; Oliveira, F. A. R.; Hogg, T. 2008. A Critical Survey of  
36 Predictive Mathematical Models for Migration from Packaging. *Critical Reviews in*  
37 *Food Science and Nutrition* 48, 913-928.  
38  
39 21  
40 22 Press, W. H.; Flannery, B. P.; Teukolsky, S. A.; Vetterling, W. T. Modelling of data. 1989  
41 Numerical Recipes in Pascal Cambridge University Press; Chapter 14 Modelling of  
42 data. pp 547-599.  
43  
44 24  
45 25 Reynier, A.; Dole, P.; Feigenbaum, A. 1999. Prediction of worst case migration: presentation  
46 of a rigorous methodology. *Food Additives and Contaminants* 16, 137-152.  
47  
48 26  
49 27 Reynier, A.; Dole, P.; Feigenbaum, A. 2001a. Additive diffusion coefficients in polyolefins.  
50 II. Effect of swelling and temperature on the  $D = f(M)$  correlation. *Journal of Applied*  
51 *Polymer Science* 82, 2434-2443.  
52  
53 29  
54 30 Reynier, A.; Dole, P.; Humbel, S.; Feigenbaum, A. 2001b. Diffusion coefficients of additives  
55 in polymers. I. Correlation with geometric parameters. *Journal of Applied Polymer*  
56 *Science* 82, 2422-2433.  
57  
58 32  
59  
60

- 1  
2  
3  
4 1 Reynier, A.; Dole, P.; Feigenbaum, A. 2002. Integrated approach of migration prediction  
5 2 using numerical modelling associated to experimental determination of key  
6 3 parameters. Food Additives and Contaminants 19, 42-55.
- 8  
9 4 Sammon, C.; Hajatdoost, S.; Eaton, P.; Mura, C.; Yarwood, J. 1999. Materials analysis using  
10 5 confocal Raman microscopy. Macromolecular Symposia 141, 247-262.
- 11  
12 6 Trujillo-Ortiz, A.; Hernandez-Walls, R.; Barba-Rojo, K.; Castro-Perez, A.  
13 7 AnDartest: Anderson-Darling test for assessing normality of a sample data. A  
14 8 MATLAB file. [WWW document]. URL  
15 9 <http://www.mathworks.com/matlabcentral/fileexchange/loadFile.do?objectId=14807>.
- 16  
17  
18  
19 10 Vitrac, O.; Lezervant, J.; Feigenbaum, A. 2006. Decision trees as applied to the robust  
20 11 estimation of diffusion coefficients in polyolefins. Journal of Applied Polymer  
21 12 Science 101, 2167-2186.
- 22  
23  
24  
25  
26  
27  
28  
29  
30  
31  
32  
33  
34  
35  
36  
37  
38  
39  
40  
41  
42  
43  
44  
45  
46  
47  
48  
49  
50  
51  
52  
53  
54  
55  
56  
57  
58  
59  
60

## Figure Captions

**Figure 1:** Preparation of a sample for the Raman analysis. The slice is cut in order that the thickness ( $2L$ ) becomes the width of the sample

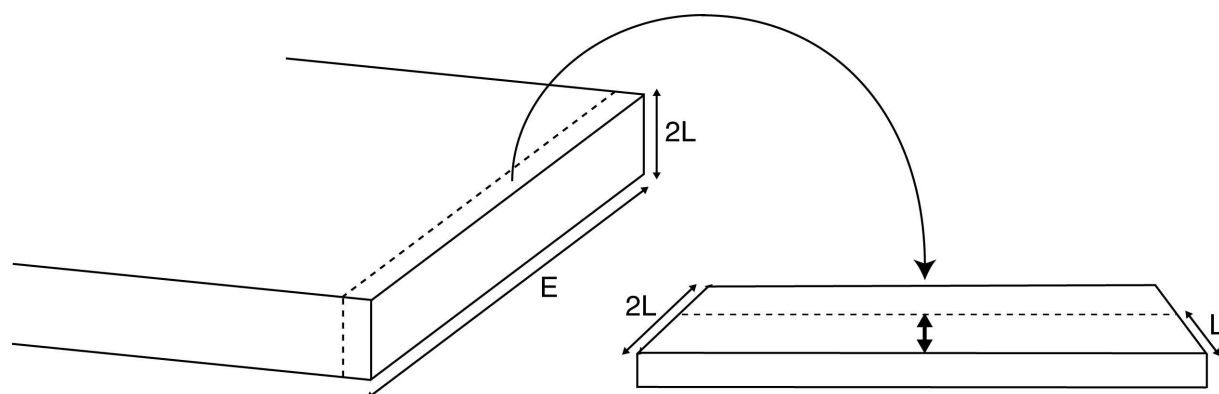
**Figure 2:** Distribution of the Uvitex OB concentration in LLDPE samples

**Figure 3.** FTIR spectral fingerprint of LLDPE + Uvitex OB. Focused region shows the band selected to follow Uvitex OB desorption and its decrease throughout the test

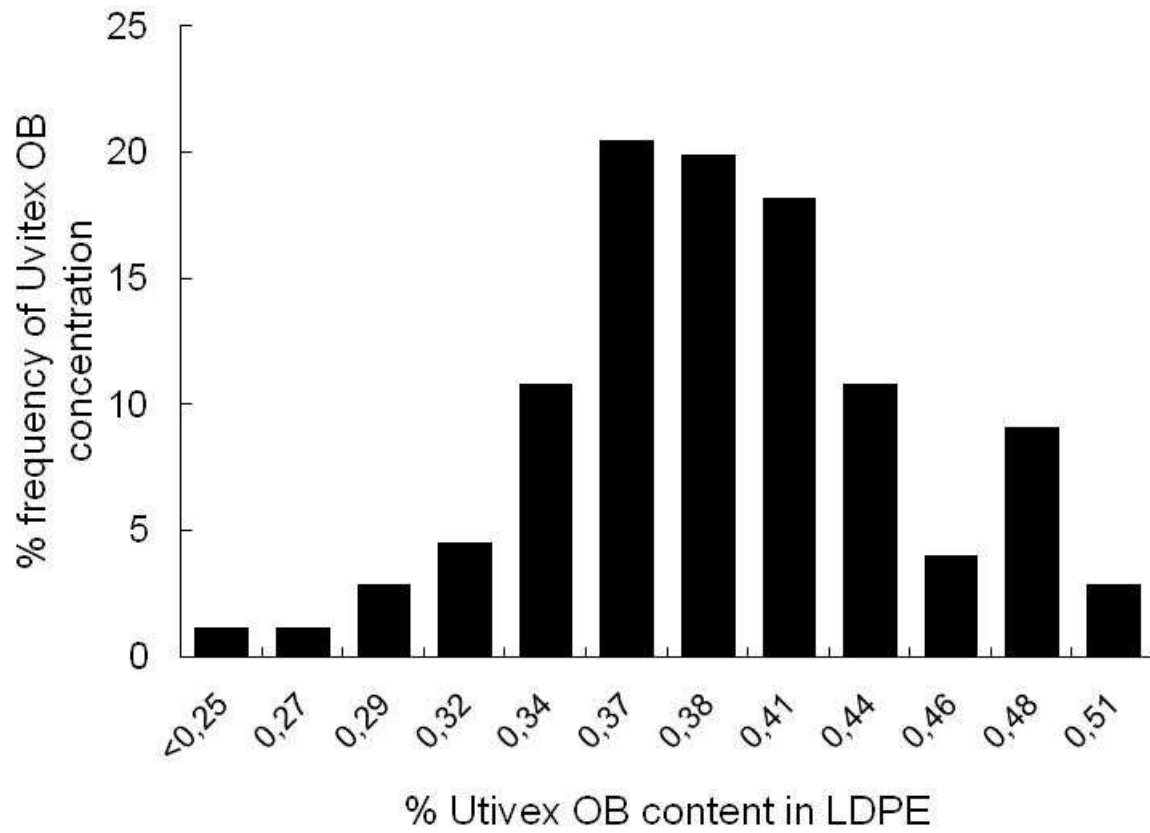
**Figure 4:** Simultaneous sorption of olive oil and desorption of Uvitex OB from LLDPE at  $40^{\circ}\text{C}$  as determined by FTIR. (● represent experimental olive oil values; □ represent experimental Uvitex OB values; continuous lines represent fitted data)

**Figure 5.** Raman spectral fingerprint of LLDPE + Uvitex OB. Focused region shows the doublet selected to follow Uvitex OB (C=N, C=C) desorption and its variation in the depth of the film

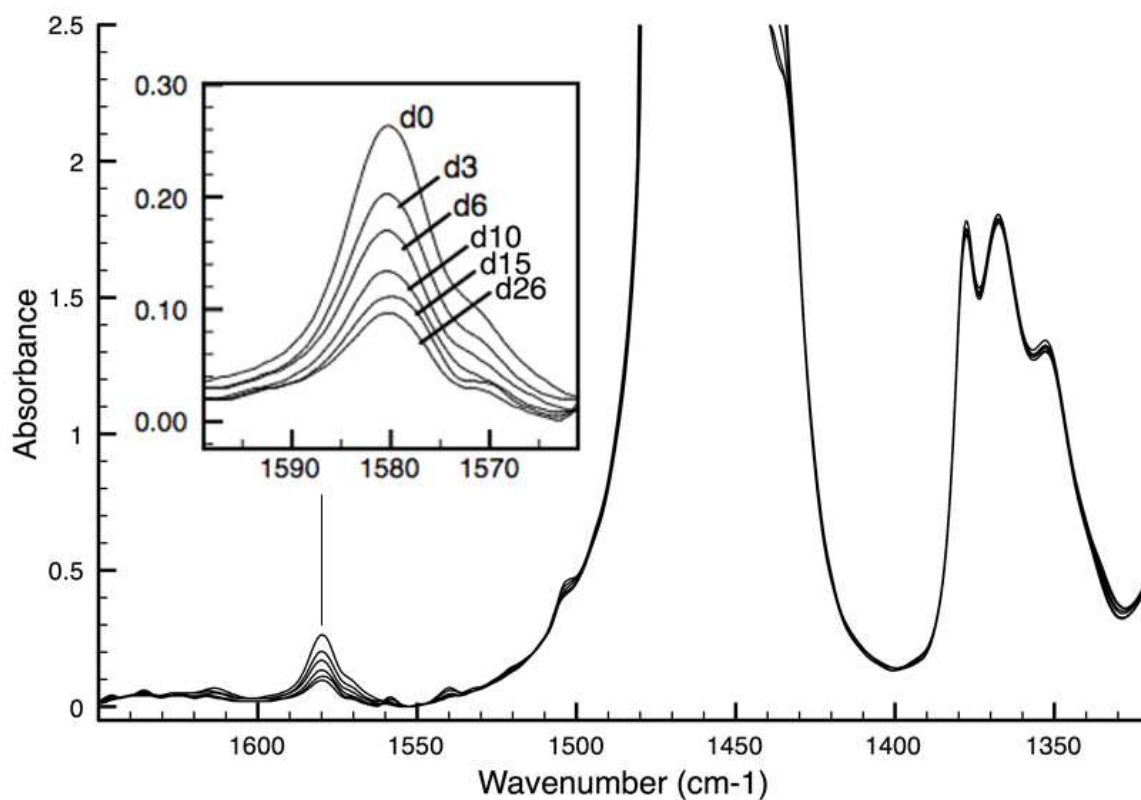
**Figure 6:** Concentration profiles of Uvitex OB within the half-depth of LLDPE film submitted to a contact with olive oil at  $40^{\circ}\text{C}$ . The profiles were obtained after 4 h (■), 1 day (○) and 3 days (▲). Continuous lines represent the profiles predicted with the value obtained in case i), Fickian kinetics.



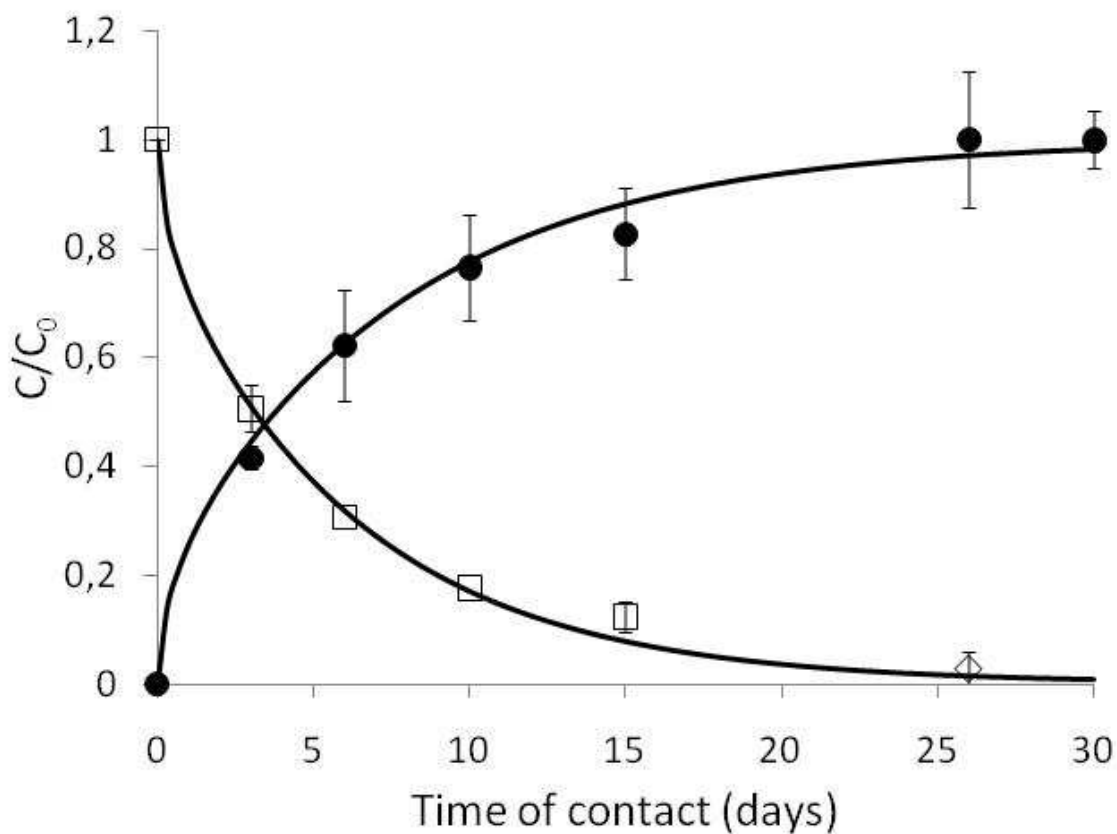
**Figure 1:** Preparation of a sample for the Raman analysis. The slice is cut in order that the thickness ( $2L$ ) becomes the width of the sample



**Figure 2:** Distribution of the Uvitex OB concentration in LLDPE samples

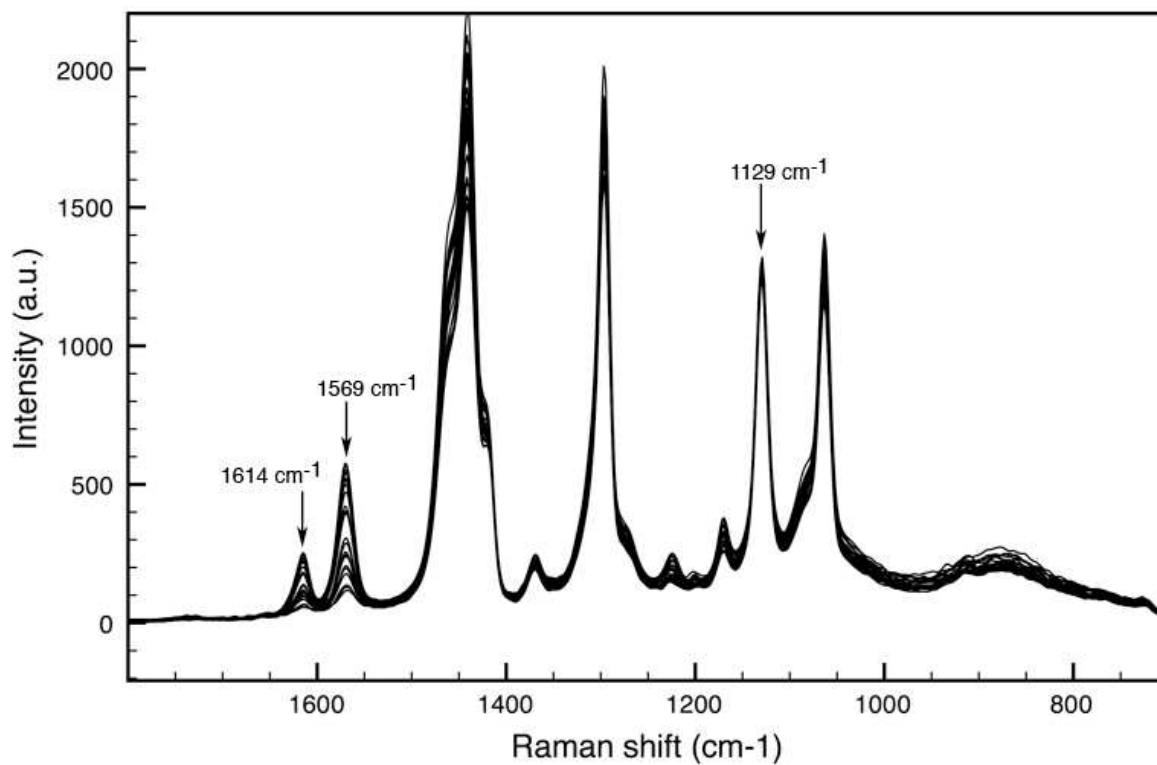


**Figure 3.** FTIR spectral fingerprint of LLDPE + Uvitex OB. Focused region shows the band selected to follow Uvitex OB desorption and its decrease throughout the test



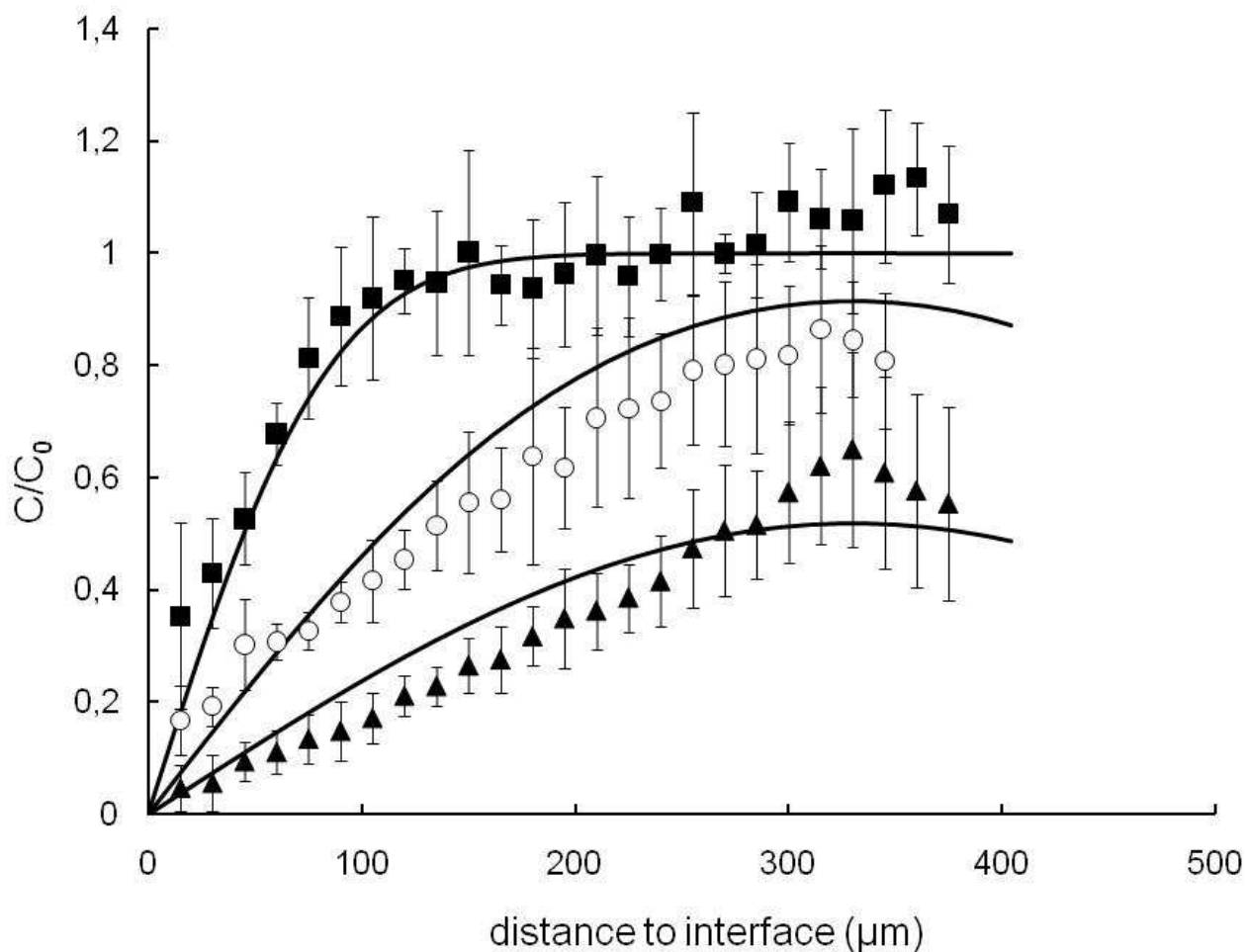
**Figure 4:** Simultaneous sorption of olive oil and desorption of Uvitex OB from LLDPE at 40°C as determined by FTIR. (● represent experimental olive oil values; □ represent experimental Uvitex OB values; continuous lines represent fitted data)

Note: Desorption point at 26 days (represented with ◇) was determined with UV spectroscopy of the additive extract



**Figure 5.** Raman spectral fingerprint of LLDPE + Uvitex OB. Focused region shows the doublet selected to follow Uvitex OB (C=N, C=C) desorption and its variation in the depth of the film





**Figure 6:** Concentration profiles of Uvitex OB within the half-depth of LLDPE film submitted to a contact with olive oil at 40°C. The profiles were obtained after 4 h (■), 1 day (○) and 3 days (▲). Continuous lines represent the profiles predicted with the value obtained in case i), Fickian kinetics.

Table 1. Values obtained after fitting of Raman data of desorption of Uvitex OB from LLDPE in olive oil at 40°C.

	$\gamma$ Uvitex OB	$\gamma$ Olive oil	$D_0$ ( $10^{-14}$ m <sup>2</sup> s <sup>-1</sup> )	RMSE (% w/w)
Case i (Fickean)			14.9 (2.5)	0.023
Case ii	0.12		14.2 (1.3)	0.023
Case iii		0	14.4 (1.3)	0.023
Case iv	0.19	0	13.3 (1.3)	0.022

Note:  $D_0$  and  $\gamma$  values are defined in equation (5). For case i) both  $\gamma$  are zero and  $D_0$  is actually the Fickean diffusivity.