



**HAL**  
open science

## Workflow analysis of production lines with complete inspection and rework loops

Giorgos Giannakis, Vassilis S Kouikoglou, Spilios Nikitas

► **To cite this version:**

Giorgos Giannakis, Vassilis S Kouikoglou, Spilios Nikitas. Workflow analysis of production lines with complete inspection and rework loops. *International Journal of Production Research*, 2010, pp.1. 10.1080/00207540903469050 . hal-00560022

**HAL Id: hal-00560022**

**<https://hal.science/hal-00560022>**

Submitted on 27 Jan 2011

**HAL** is a multi-disciplinary open access archive for the deposit and dissemination of scientific research documents, whether they are published or not. The documents may come from teaching and research institutions in France or abroad, or from public or private research centers.

L'archive ouverte pluridisciplinaire **HAL**, est destinée au dépôt et à la diffusion de documents scientifiques de niveau recherche, publiés ou non, émanant des établissements d'enseignement et de recherche français ou étrangers, des laboratoires publics ou privés.



**Workflow analysis of production lines with complete inspection and rework loops**

Journal:	<i>International Journal of Production Research</i>
Manuscript ID:	TPRS-2009-IJPR-0387.R2
Manuscript Type:	Original Manuscript
Date Submitted by the Author:	30-Oct-2009
Complete List of Authors:	Giannakis, Giorgos; Technical University of Crete, Dept of Production Engineering and Management Kouikoglou, Vassilis; Technical University of Crete, Dept of Production Engineering and Management Nikitas, Spilios; Technical University of Crete, Dept of Production Engineering and Management
Keywords:	FLOW LINES, INSPECTION, QUEUEING NETWORKS, INVENTORY CONTROL
Keywords (user):	Inspection allocation



## Workflow analysis of production lines with complete inspection and rework loops

GIORGOS GIANNAKIS, VASSILIS S. KOUIKOGLOU\*, and SPILIOS NIKITAS

*Department of Production Engineering and Management, Technical University of Crete, University Campus, GR-73100 Chania, Greece.*

We study the flows induced by different rework loops in serial manufacturing systems with inspection stations. Average values of these flows and queueing network formulas are used for performance evaluation and optimization of production lines. An application is presented for solving jointly the problems of inventory control and inspection station allocation in a CONWIP production line.

**Keywords:** Flow lines; Inspection allocation; Queueing networks; Inventory control.

### 1. Introduction

This paper studies the flow of items in production lines with inspection, rework and scrapping of items and solves related analysis and optimization problems. The analysis of production processes with rework loops and scrapping presents combinatorial difficulties.

Consider, for example, a flow line in which items visit machines  $M_1$ ,  $M_2$  and  $M_3$  sequentially and are then sent to an inspection station. Each end item is inspected for defects. If all defects can be fixed, the item is sent back to the machines which performed the defective operations and, after completing a rework cycle therein, it is sent back to the inspection station. In general, an item entering the inspection station belongs to one of the following nine classes: [scrap], [conforming], [needs rework only at  $M_1$ ], [needs rework only at  $M_2$ ], [needs rework only at  $M_3$ ], [needs rework at  $M_1$  and  $M_2$ ], [needs rework at  $M_1$  and  $M_3$ ], [needs rework at  $M_2$  and  $M_3$ ], and

---

\*Corresponding author. Email: kouik@dpem.tuc.gr

1  
2  
3  
4 [needs rework at  $M_1$ ,  $M_2$  and  $M_3$ ]. Each one of these classes has its own  
5 routing matrix. Therefore, the outcome of each inspection or re-inspection  
6 and the routing of items in the system depend on each item's history of  
7 previous processings, as pointed out in Lee *et al.* (1999). In a flow line with  
8  $K$  machines there are a total of  $2^K + 1$  distinct classes and corresponding  
9 routings. An even more complicated situation arises when the probability of  
10 an operation being conforming or non-conforming depends on the number  
11 of times the operation has been repeated on the same item.  
12  
13  
14  
15  
16  
17  
18

19 In the literature, rework loops are usually ignored or assumed to be  
20 fixed in number and involve only sequential operations.  
21  
22

23 Lindsay and Bishop (1965), White (1969), and Britney (1972) were  
24 among the first to study the problem of allocating inspection effort in  
25 multistage systems without rework loops. Because the cost functions  
26 involved are linear or multi-linear, either complete inspection or no  
27 inspection is optimal for each stage. Eppen and Hurst (1974), Yum and  
28 McDowell (1981, 1987), and Rau *et al.* (2005) study systems with rework  
29 and imperfect inspection accuracy. In these systems the outgoing quality,  
30 rework, and inspection costs are the main components of system  
31 performance. The statistics of flows due to rework, scrapping and  
32 replacement of defective items, as well as their impact on the processing  
33 times and inventory were first studied in Seidman and Nof (1985) and  
34 Tapiero and Hsu (1987) for single-stage production systems. Since then, the  
35 operational analysis of production systems with several machines and  
36 rework loops has received considerable attention (see, e.g., Wittrock 1992,  
37 Kim *et al.* 1995, Crowley *et al.* 1995, Narahari and Khan 1996, Lee *et al.*  
38 1999, Li 2004, Ioannidis *et al.* 2004, and Pradhan and Damodaran 2008).  
39 The papers by Raz (1986) and Mandroli *et al.* (2006) provide surveys on the  
40 inspection allocation problem.  
41  
42  
43  
44  
45  
46  
47  
48  
49  
50  
51  
52  
53  
54

55 All the models above, with the exception of that in Lee *et al.* (1999),  
56 assume simple rework loops which involve a single machine or a chain of  
57 sequential operations immediately preceding the inspection station. More  
58  
59  
60

1  
2  
3  
4  
5  
6  
7  
8  
9  
10  
11  
12  
13  
14  
15  
16  
17  
18  
19  
20  
21  
22  
23  
24  
25  
26  
27  
28  
29  
30  
31  
32  
33  
34  
35  
36  
37  
38  
39  
40  
41  
42  
43  
44  
45  
46  
47  
48  
49  
50  
51  
52  
53  
54  
55  
56  
57  
58  
59  
60

general rework routings are usually ignored or approximated, as for example in Wittrock (1992) where the rework possibilities are truncated by ignoring “sufficiently improbable” ones. Lee *et al.* (1999) present queueing models for a three-stage system with random inspection at each stage, which take into account all rework combinations of the three operations. For each processing stage, their models calculate the mean flow rates induced by first-pass and rework flows into that stage. System throughput, average outgoing quality, inspection frequencies, and average inventory levels are then computed using decomposition methods (exact and approximate) and Markov chain analysis.

In this paper, we examine production lines of any size with distinct rework loops, in which the probability of a nonconforming operation may depend on the number of times this operation has been repeated on the same item. In section 2 we derive expressions for the mean workload of each machine and the outgoing quality of the system. We use these quantities in section 3 to evaluate the performance of a production line. Section 4 presents an application to the problem of inventory control and inspection station allocation. Section 5 discusses possible extensions.

## 2. Yield rate and visit ratios in production lines with scrapping and rework

We examine flow lines with complete inspection, scrapping of items and rework loops, and derive analytical expressions for two performance indices: the *yield rate*, defined as the fraction of raw items that are not scrapped, and the *visit ratios* or mean number of visits at each machine and each inspection station, before an item is disposed off as scrap or declared as conforming product. In Section 3 we shall derive important performance indices with the use of visit ratios and the yield rate.

The method used to compute visit ratios and the yield rate avoids enumerating explicitly the different rework routings. First, we study a production line with a single inspection/repair station; then we extend the

1  
2  
3  
4  
5  
6  
7  
8  
9  
10  
11  
12  
13  
14  
15  
16  
17  
18  
19  
20  
21  
22  
23  
24  
25  
26  
27  
28  
29  
30  
31  
32  
33  
34  
35  
36  
37  
38  
39  
40  
41  
42  
43  
44  
45  
46  
47  
48  
49  
50  
51  
52  
53  
54  
55  
56  
57  
58  
59  
60

results to lines with several inspection/repair stations; we also study systems with group rework, i.e., if an operation has to be repeated, then all operations in the same group must be repeated as well.

### 2.1. Single inspection station

Consider the production line shown in figure 1. Assume it operates according to the following assumptions:

- (i) The production line consists of  $K$  machines,  $M_1, \dots, M_K$ , followed by a single quality inspection/repair station, IS. Machine  $M_i$  performs a specific operation, denoted  $i$ . Station IS inspects the finished items for *repairable* (minor), *reworkable* and *unrestorable* defects, and repairs items with minor defects. Reworkable items are sent back for rework to the machines which performed the defective operations. Items with unrestorable defects are declared as scrap and are replaced by new raw items. For simplicity, both conforming and repairable items and operations will be referred to as conforming, since they do not have to be reworked. Conforming items are sent to the output buffer.
- (ii) The quality of operation  $i$  may depend on the number of times the same workpiece has already been reworked at  $M_i$ , but it is independent of the quality of other operations.
- (iii) At the exit of each stage, semifinished workpieces *may be* subject to a *rough* (e.g., visual) *inspection*, which removes *only a fraction* of the items that have acquired an unrestorable defect at that stage. The probability that an item is disposed off as scrap immediately after operation  $i$  is  $s_{i,x}$ , where  $x$  is the number of times this item has passed through  $M_i$ .
- (iv) Suppose that a finished item, either first-pass or reworked, is inspected in IS after having completed a sequence of processing steps involving the  $x$ th pass through  $M_i$ ,  $x \geq 1$ . Then, operation  $i$  is declared as conforming (including the case of a repairable operation) with

probability  $c_{i,x}$ , reworkable with probability  $r_{i,x}$ , and unrestorable with probability  $t_{i,x}$ .

- (v) The inspection and repair operations at station IS are assumed to be free of errors. Yet, rough inspection may be fraught with errors of both types:  $1 - s_{i,x}$  is the fraction of conforming and restorable items as well as items with unrestorable defects misclassified as conforming or restorable ones;  $s_{i,x}$  is the fraction of items with unrestorable defects as well as conforming or restorable workpieces misclassified as unrestorable ones. When rough inspection is not present we set  $s_{i,x} = 0$ .

insert Figure 1 about here

The probabilities  $c_{i,x}$ ,  $r_{i,x}$ ,  $s_{i,x}$ , and  $t_{i,x}$  will be referred to as the *quality probabilities* and they satisfy  $c_{i,x} + r_{i,x} + s_{i,x} + t_{i,x} = 1$ , for all  $x = 1, 2, \dots$  and  $i = 1, \dots, K$ . These probabilities determine the yield rate of the system and the distributions of the number of inspections and number of reworks of each item before it leaves the system as a conforming product or scrap. In practice, an item can be reworked only a finite number of times  $X$  before it is either discarded as scrap and replaced by a new raw item or becomes a conforming product. Other rework models in the literature assume that  $r_{i,x}$  is independent of the number of passes  $x$ . These assumptions are generalized as follows: There is a fixed integer  $X$  such that

- (a) the quality probabilities for  $x > X$  are equal to the corresponding probabilities for  $X$
- (b)  $r_{i,X} < 1$ .

When  $r_{i,X} = 0$ , operation  $i$  cannot be repeated more than  $X$  times. Because, by assumption (a),  $r_{i,x} = r_{i,X}$  for all  $x > X$ , the case  $r_{i,X} = 1$  does not represent a realistic situation, as it implies that if operation  $i$  is not successful after  $X - 1$  trials, then it is repeated for ever. Finally, if  $r_{i,x} \in (0,$

1), then, with probability one, each item is reworked a finite number of times at  $M_i$  before it is either scrapped or produced successfully. For example, suppose that if operation 1 is performed on the same item four times, then the item is scrapped. The quality probabilities of the remaining operations  $i \neq 1$  are independent of  $x$  with  $r_i < 1$ . In this case, we set  $X = 4$ ,  $c_{1,x} = r_{1,x} = t_{1,x} = 0$  and  $s_{1,x} = 1$  for  $x \geq 4$ , and assumptions (a) and (b) above are satisfied for all machines  $M_i$ .

In the sequel, we drop the subscript  $x$  in the notation of the quality probabilities when  $x \geq X$ . We thus have  $c_i = c_{i,X}$ ,  $r_i = r_{i,X} < 1$ ,  $s_i = s_{i,X}$ , and  $t_i = t_{i,X}$ .

We now define three quantities which will be used in deriving expressions for the yield rate and visit ratios. First, consider machine  $M_i$  operating in isolation. The quantity

$$C_i(n) = c_{i,1} + r_{i,1}c_{i,2} + \dots + (r_{i,1}\dots r_{i,n-1}c_{i,n}) \quad (1)$$

is the probability that  $M_i$  will perform a conforming operation  $i$  on an item in at most  $n$  passes. Note that  $C_i(n)$  is increasing in  $n$ . The yield rate of  $M_i$  in isolation is  $C_i = \lim_{n \rightarrow \infty} C_i(n)$ . Because the quality probabilities are constant for  $x \geq X$  and also  $r_{i,x} = r_i < 1$ , the yield rate of  $M_i$  in isolation is given by

$$\begin{aligned} C_i &= c_{i,1} + r_{i,1}c_{i,2} + \dots + (r_{i,1}\dots r_{i,X-2}c_{i,X-1}) + (r_{i,1}\dots r_{i,X-1})(c_i + r_i c_i + \dots) \\ &= c_{i,1} + r_{i,1}c_{i,2} + \dots + (r_{i,1}\dots r_{i,X-2}c_{i,X-1}) + (r_{i,1}\dots r_{i,X-1}) \frac{c_i}{1 - r_i}. \end{aligned} \quad (2)$$

If  $X = 1$ , then  $C_i = c_i/(1 - r_i)$ .

Next, we consider the  $K$ -machine line and compute the probability  $P_i(n)$  that an item passes through  $M_i$  at least  $n$  times. In particular, the probability  $P_i(1)$  of at least one pass through  $M_i$  equals the probability that the item will not be discarded due to immediate scrapping during its first pass through the preceding machines. Thus,  $P_i(1) = (1 - s_{1,1})(1 - s_{2,1})\dots(1 - s_{i-1,1})$ . In general, an item will visit  $M_i$  at least  $n$  times if the following events occur simultaneously:



- operation  $i$  is reworkable after the first  $n - 1$  passes
- the downstream operations  $j > i$  are either conforming or reworkable after the first  $n - 1$  visits to the corresponding machines
- the upstream operations  $j < i$  are either conforming after at most  $n - 1$  passes through  $M_j$  or reworkable but the item is not scrapped immediately after its  $n$ th pass.

Combining the above we obtain

$$P_i(n) = (r_{i,1} \dots r_{i,n-1}) \left\{ \prod_{j>i} [C_j(n-1) + r_{j,1} \dots r_{j,n-1}] \right\} \\ \times \left\{ \prod_{j<i} [C_j(n-1) + r_{j,1} \dots r_{j,n-1}(1 - s_{j,n})] \right\}. \quad (3)$$

Finally, we compute the probability  $P_{IS}(n)$  that an item will pass from the inspection/rework station IS *at least*  $n$  times. In particular,  $P_{IS}(1)$  equals the probability that the item will not be scrapped during its first pass through the system. Thus,  $P_{IS}(1) = (1 - s_{1,1})(1 - s_{2,1}) \dots (1 - s_{K,1})$ . The item will be inspected at least  $n$  times if the following events occur simultaneously:

- each operation  $i$  is either conforming after the first  $n - 1$  passes through  $M_i$  or reworkable but the item is not scrapped immediately after its  $n$ th pass
- not all operations are conforming after the first  $n - 1$  passes.

Therefore,

$$P_{IS}(n) = \prod_{i=1}^K [C_i(n-1) + r_{i,1} \dots r_{i,n-1}(1 - s_{i,n})] - \prod_{i=1}^K C_i(n-1). \quad (4)$$

We now give the main results of this section.

**Proposition 1:** The yield rate of a production line with a single inspection/repair station IS is the product of the yield rates of its machines in isolation:

$$C_{IS} = \prod_{i=1}^K C_i. \quad (5)$$

**Proof:** An end item is conforming if it has successfully received all operations. The proof follows from the assumption that the quality of each operation is independent of the quality of others.

**Proposition 2:** The visit ratios of an item at  $M_i$  and at the inspection/rework station IS are the limits of the sequences

$$\begin{aligned} N_i(n) &= P_i(1) + P_i(2) + \dots + P_i(n) \\ N_{IS}(n) &= P_{IS}(1) + P_{IS}(2) + \dots + P_{IS}(n) \end{aligned} \quad (6)$$

as  $n \rightarrow \infty$ .

**Proof:** It follows from the fact that the mean value of a nonnegative integer random variable  $x$ ,  $x = 0, 1, \dots$ , is given by  $E(x) = P(x \geq 1) + P(x \geq 2) + \dots$

The infinite series  $N_i = N_i(\infty)$  and  $N_{IS} = N_{IS}(\infty)$  do not have closed form expressions. Therefore, they must be truncated for computational purposes.

**Remark:** Feedback loops similar to the rework routings examined herein arise also in the analysis of research and development projects, where parts of a project can fail and need to be done again. Truncation is the only recipe to get around this problem. Wittrock (1992) develops a network model named Orchard for manufacturing systems and quotes: "Of course, Orchard cannot explicitly store an infinite tree. It avoids this by ignoring sufficiently improbable visits." Also in Section 17.4.4 of their book, Morton and Pentico (1993) comment on loopbacks in stochastic project networks as follows: "A reasonable way out of this difficulty is to remove (prune) branches of less than a certain minimum probability and to fudge their consequences roughly into their more important neighbors. This procedure is necessarily

judgemental in nature ....”

To approximate  $N_i$  by  $N_i(n)$ , we seek a truncation value  $n \geq X$  such that the error  $P_i(n+1) + P_i(n+2) + \dots$  is smaller than a specified value  $\varepsilon$ . Consider a term  $P_i(k)$  of the error, where  $k > X$ . From equation (3), we have

$$P_i(k) = (r_{i,1} \dots r_{i,k-1}) \left\{ \prod_{j>i} [C_j(k-1) + r_{j,1} \dots r_{j,k-1}] \right\} \\ \times \left\{ \prod_{j<i} [C_j(k-1) + r_{j,1} \dots r_{j,k-1}(1-s_{j,k})] \right\}.$$

Because  $r_{i,x} \leq 1$  for all  $x$  and  $r_{i,k} = r_i$  for all  $k > X$ , we have that

$$(r_{i,1} \dots r_{i,k-1}) = (r_{i,1} \dots r_{i,X-1}) r_i^{k-X-1} \leq r_i^{k-X-1}.$$

For  $j \neq i$ , it suffices to consider the relaxed inequality  $r_{j,1} r_{j,2} \dots r_{j,k-1} \leq 1$ .

Finally, because the sequence  $C_j(k)$  is monotonically increasing to  $C_j$  as  $k \rightarrow \infty$ , we have  $C_j(k-1) \leq C_j$ . From the previous three inequalities we obtain the bounds

$$P_i(k) \leq r_i^{k-X-1} \prod_{j \neq i} (C_j + 1), \quad k \geq n + 1, \\ P_i(n+1) + P_i(n+2) + \dots \leq \frac{\prod_{j \neq i} (C_j + 1)}{1 - r_i} r_i^{n-X}.$$

If we define

$$A_i = \frac{\prod_{j \neq i} (C_j + 1)}{1 - r_i}, \quad (7)$$

then  $n$  must satisfy  $A_i r_i^{n-X} \leq \varepsilon$ . By taking logarithms on both sides and noting that  $\log r_i < 1$ , we see that the smallest truncation value  $n = n_i$  that guarantees a maximum error  $\varepsilon$  in estimating  $N_i$  is

$$n_i = X + \begin{cases} \left\lceil \frac{\log \varepsilon - \log A_i}{\log r_i} \right\rceil, & A_i > \varepsilon \\ 0, & \text{otherwise,} \end{cases} \quad (8)$$

where  $\lceil y \rceil$  is the smallest integer greater than  $y$ .

Next, we determine a truncation value  $n$  for approximating the visit ratio at the inspection station by  $N_{IS}(n)$ . The approximation error is  $P_{IS}(n+1) + P_{IS}(n+2) + \dots$ . Consider a term  $P_{IS}(k)$ ,  $k \geq n+1$ , of the error

$$P_{IS}(k) = \prod_{i=1}^K [C_i(k-1) + r_{i,1} \dots r_{i,k-1} (1 - s_{i,k})] - \prod_{i=1}^K C_i(k-1).$$

It can be shown by differentiation that  $P_{IS}(k)$  is an increasing function of  $C_i(k-1)$  and  $r_{i,1} \dots r_{i,k-1} (1 - s_{i,k})$ . Because  $C_i(k-1) \leq C_i$  for all  $k$  and  $r_{i,1} \dots r_{i,k-1} (1 - s_{i,k}) \leq r_i^{k-X-1}$  for  $k > n \geq X$ , we see that

$$\begin{aligned} P_{IS}(k) &\leq \prod_{i=1}^K (C_i + r_i^{k-X-1}) - \prod_{i=1}^K C_i \\ &\leq (A + r_{IS}^{k-X-1})^K - A^K \end{aligned}$$

where we have defined

$$A = \max_i C_i, \quad r_{IS} = \max_i r_i \quad (9)$$

From the binomial theorem we obtain

$$P_{IS}(k) \leq \sum_{j=1}^K \binom{K}{j} A^{K-j} (r_{IS}^{k-X-1})^j < \left[ \sum_{j=1}^K \binom{K}{j} A^{K-j} \right] r_{IS}^{k-X-1}$$

where the strict inequality follows from the fact that  $r_i < 1$  implies  $r_{IS} < 1$ , from which we have  $(r_{IS}^{k-X-1})^j < r_{IS}^{k-X-1}$  for  $j > 1$ . The approximation error is bounded from above as follows

$$\begin{aligned} P_{IS}(n+1) + P_{IS}(n+2) + \dots &< \left[ \sum_{j=1}^K \binom{K}{j} A^{K-j} \right] \left( \sum_{k=n+1}^{\infty} r_{IS}^{k-X-1} \right) \\ &= [(A+1)^K - A^K] \frac{r_{IS}^{n-X}}{1 - r_{IS}}. \end{aligned}$$

Therefore, if we define

$$A_{IS} = \frac{(A+1)^K - A^K}{1 - r_{IS}}, \quad (10)$$

then the smallest truncation value  $n = n_{IS}$  that guarantees a maximum error  $\varepsilon$  in estimating  $N_{IS}$  is given by

$$n_{IS} = X + \begin{cases} \left\lceil \frac{\log \varepsilon - \log A_{IS}}{\log n_{IS}} \right\rceil, & A_{IS} > \varepsilon \\ 0, & \text{otherwise.} \end{cases} \quad (11)$$

The following algorithm can be used to compute the yield rate and visit ratios for a production line with a single inspection station.

**Algorithm 1:**

1. Compute  $C_i$ ,  $i = 1, \dots, K$ , from equation (2) and  $C_{IS}$  from (5).
2. Compute  $A_i$ ,  $i = 1, \dots, K$ , from equation (7),  $n_i$  from (8), and  $N_i \approx N_i(n_i)$  from equations (1), (3) and (6).
3. Compute  $A$ ,  $r_{IS}$  and  $A_{IS}$  from equations (9) and (10),  $n_{IS}$  from (11), and  $N_{IS} \approx N_{IS}(n_{IS})$  from equations (1), (4) and (6).

**Example 1:** Consider a production line with ten machines having the same quality probabilities, independent of the number of reworks. Let  $c_i = 0.9$ ,  $r_i = 0.09$ , and  $s_i + t_i = 0.01$  but  $s_i$  and  $t_i$  are otherwise arbitrary. Then, setting  $X = 1$  in equation (2), we find  $C_i = c_i/(1 - r_i) = 0.989$ ; the overall yield rate is  $0.989^{10} = 0.895$ . For every  $i = 1, \dots, 10$ , equation (7) gives  $A_i = 1.989^9/(1 - r_i) = 535$ , and for a maximum error  $\varepsilon = 10^{-7}$ , equation (8) with logarithms of base ten gives the truncation value

$$n_i = X + \lceil (-7 - \log 535)/\log 0.09 \rceil = 1 + \lceil 9.3 \rceil = 11.$$

Setting  $A = \max_i C_i = 0.989$ ,  $r_{IS} = \max_i r_i = 0.09$  in equation (10) we obtain  $A_{IS} = (1.989^{10} - 0.989^{10})/(1 - r_{IS}) = 1064$ , and, upon substituting this into equation (11), we obtain

$$n_{IS} = X + \lceil (-7 - \log 1064)/\log 0.09 \rceil = 1 + \lceil 9.6 \rceil = 11.$$

Therefore, at most eleven terms are required in equations (6) to approximate

the visit ratios  $N_i$  and  $N_{IS}$  with errors less than  $10^{-7}$ . To reduce the error to  $10^{-8}$  we need one additional term in equations (6).

## 2.2. Multiple inspection stations and adjusted visit ratios

We now consider a production line with  $K$  machines and  $NS \geq 1$  inspection stations. Station IS inspects and repairs all items that complete a specific subset of consecutive operations. Both the subset of operations and the set of machines which perform them will be referred to as *chains* (of station) IS. Figure 2 shows a production line with two chains of operations, chain 1 = {1, 2} and chain 2 = {3, 4}.

insert Figure 2 about here

Not all conforming items that depart from a chain end up conforming products. For example a conforming item leaving chain 1 and entering  $M_3$  may eventually be scrapped if it acquires an unrestorable defect at some subsequent production stage.

To take into account the possibility of scrapping at subsequent chains, we define the *adjusted visit ratio*  $V_i$  to be the mean number of visits to machine  $M_i$  per conforming product of the system. Each item entering chain IS ends up a conforming product with probability  $C_{IS}C_{IS+1}\dots C_{NS}$  and also each such item passes on average  $N_i$  times through  $M_i$  and is inspected  $N_{IS}$  times. Thus the adjusted visit ratios are given by

$$V_i = \frac{N_i}{C_{IS}C_{IS+1}\dots C_{NS}} \quad (12)$$

for all machines  $M_i$  belonging to chain IS and also for the inspection station,  $i = IS$ .

The overall yield rate  $C$  of a production line with  $NS$  chains and  $K$  machines is the product of the yield rates of its chains or its machines in

isolation, i.e.,

$$C = \prod_{IS=1}^{NS} C_{IS} = \prod_{i=1}^K C_i . \quad (13)$$

### 2.3. Group scrapping and rework

So far, we have assumed that the qualities of operations are independent of each other, so that an item may need rework at  $M_1$  but not at  $M_2$ . We now examine the case of tend the previous results to take into account group scrapping and rework. Suppose that, instead of a single machine  $M_i$ , we have a group of  $K_i$  consecutive machines, denoted  $M_{i,m}$ ,  $m = 1, \dots, K_i$ , such that whenever an item must be reworked at  $M_{i,m}$ , all operations in group  $i$  must be repeated as well, provided none of them renders the item scrapped.

An item that enters machine  $M_{i,m}$  for its  $x$ th rework receives a conforming operation with probability  $c_{i,m,x}$ , a reworkable operation with probability  $r_{i,m,x}$ , or it becomes a scrap item, either right after the item completes all group  $i$  operations with probability  $s_{i,m,x}$  or after inspection (at the end of the chain to which group  $i$  belongs) with probability  $t_{i,m,x}$ .

When several groups are inspected by a single inspection station, they form a chain as explained in the previous section. In this case, we can describe group  $i$  using an *equivalent machine*  $M_i$  whose quality probabilities can be computed as follows.

a) The probability of a conforming operation during the  $x$ th rework in group  $M_i$  is the product of the corresponding probabilities of  $M_{i,m}$ . That is,

$$c_{i,x} = \prod_{m=1}^{K_i} c_{i,m,x} .$$

b) Similarly, the probability that an item will be either conforming or reworkable after its  $x$ th pass through group  $i$  equals the product of the corresponding probabilities of  $M_{i,m}$ . Subtracting the probability of conforming group operations we obtain the rework probability, thus

$$r_{i,x} = \prod_{m=1}^{K_i} (c_{i,m,x} + r_{i,m,x}) - \prod_{m=1}^{K_i} c_{i,m,x}.$$

c) An item will be scrapped *immediately after its xth pass through group i* if at least one operation renders the item scrap. The corresponding probability is given by the sum of probabilities of mutually exclusive events as follows:

$$s_{i,x} = s_{i,1,x} + (1 - s_{i,1,x})s_{i,2,x} + \dots + [(1 - s_{i,1,x}) \dots (1 - s_{i,K_i-1,x})]s_{i,K_i,x}.$$

d) Finally,  $t_{i,x} = 1 - c_{i,x} - r_{i,x} - s_{i,x}$ .

In a group of machines with group scrapping and rework, each rework loop involves all machines of the group. Therefore the adjusted visit ratios and yield rate of each machine  $M_{i,m}$  are the same as those of the equivalent machine  $M_i$ , for all  $m = 1, \dots, K_i$ . The analysis of sections 2.1 and 2.2 applies here as well.

Now suppose that an item is scrapped with probability  $s_{i,m,x}$  *immediately after it passes through  $M_{i,m}$*  rather than through the whole group. Here we have the case of group rework but immediate scrapping. The quality parameters of the equivalent machine  $M_i$  are the same as above. The visit ratio of the equivalent machine is equal to the visit ratio of the *first* machine  $M_{1,i}$  of the group, but it is greater than the visit ratios of the other machines, because a reworkable item always passes through  $M_{i,1}$  but may be scrapped before it visits a downstream machine of group  $i$ . The visit ratios of the downstream machines  $M_{i,2}, M_{i,3}, \dots$  can be computed using the same arguments as those for equation (3).

### 3. Analysis of a CONWIP line with inspection stations and lost sales

This section describes a practical application of the results of section 2. Consider a production line with  $K$  machines and NS inspection stations, in which the total inventory (raw items, semi-finished items, products) is kept constant and equal to  $S$ . It is assumed that there is ample storage space before each machine so that no blocking phenomena take place. The system



1  
2  
3  
4  
5  
6  
7  
8  
9  
10  
11  
12  
13  
14  
15  
16  
17  
18  
19  
20  
21  
22  
23  
24  
25  
26  
27  
28  
29  
30  
31  
32  
33  
34  
35  
36  
37  
38  
39  
40  
41  
42  
43  
44  
45  
46  
47  
48  
49  
50  
51  
52  
53  
54  
55  
56  
57  
58  
59  
60

begins with  $S$  raw items before the first machine  $M_1$ . Whenever a product is sold to a customer or a semi-finished item is scrapped, a new raw item is released into  $M_1$ . Such systems, known as CONWIP (CONstant Work In Process) systems, are frequently encountered in practice because their inventory can easily be controlled (Spearman and Zazanis 1992).

Suppose that all demand arriving during stockouts is lost. Let  $\mu_0$  be the mean demand rate and  $\mu_i$  the mean processing rate of machine  $M_i$ , if  $i = 1, \dots, K$ , or the mean inspection rate of station IS, if  $i = K + IS$ , where  $IS = 1, \dots, NS$ . Thus, the demand and the inspection stations can be modelled by equivalent machines with known production rates.

For simplicity, we assume that workpieces after each operation  $i$ ,  $i = 1, \dots, K$ , either conform or need rework or are scrapped immediately or after inspection, with corresponding probabilities  $c_i$ ,  $r_i$ ,  $s_i$  and  $t_i$  independent of the number of previous reworks.

Let us compute the adjusted visit ratios  $V_i$  at each service node of the system. The adjusted visit ratio of  $M_0$  is assumed to correspond to the satisfied demand. Therefore, we set  $V_0 = 1$  because an arriving customer requires one conforming product. Each inspection station serves a chain of machines. Let  $IS_i$  denote both the chain and the inspection station that correspond to machine  $M_i$ . If machine  $M_j$  belongs to the same chain as  $M_i$ , then we write  $j \in IS_i$ .

Next we compute the visit ratios  $N_i$  for each  $i = 1, \dots, K + NS$  using Algorithm 1. For any  $j \leq K$ , equations (1) and (2) simplify to

$$C_j(n-1) = c_j \frac{1 - r_j^{n-1}}{1 - r_j}, \quad C_j = \frac{c_j}{1 - r_j}.$$

By considering all machines  $M_j$  in the same group with  $M_i$ ,  $IS = IS_i$ , equation (3), which gives the tails of the distribution of the number of visits at  $M_i$ , becomes

$$P_i(n) = r_i^{n-1} \prod_{j \in \text{IS}, j > i} \left[ c_j \frac{1 - r_j^{n-1}}{1 - r_j} + r_j^{n-1} \right] \prod_{j \in \text{IS}, j < i} \left[ c_j \frac{1 - r_j^{n-1}}{1 - r_j} + r_j^{n-1} (1 - s_j) \right]$$

for  $\text{IS} = \text{IS}_i$  and  $i = 1, \dots, K$ . Also equation (4), for inspection station  $\text{IS}$ , becomes

$$P_{K+\text{IS}}(n) = \prod_{j \in \text{IS}} \left[ c_j \frac{1 - r_j^{n-1}}{1 - r_j} + r_j^{n-1} (1 - s_j) \right] - \prod_{j \in \text{IS}} \left[ c_j \frac{1 - r_j^{n-1}}{1 - r_j} \right],$$

$\text{IS} = 1, \dots, \text{NS}$ , where the index  $\text{IS}$  of inspection stations is changed to  $K + \text{IS}$  to avoid confusion with the corresponding probabilities of ordinary machines. Equation (5), which gives the yield rate of chain  $\text{IS}$ , is written as

$$C_{K+\text{IS}} = \prod_{j \in \text{IS}} C_j.$$

The remaining calculations for computing the visit ratios  $N_i$ ,  $i = 1, \dots, K + \text{NS}$ , involve equations (6)–(11), as described in Algorithm 1.

Suppose that machine chains and inspection stations are visited in increasing order of  $\text{IS}$ . Then, equation (12) for any machine  $M_i$  of chain  $\text{IS} = \text{IS}_i$  reads as follows, after re-indexing the yield rates,

$$V_i = \frac{N_i}{C_{K+\text{IS}} C_{K+\text{IS}+1} \dots C_{K+\text{NS}}},$$

and for the inspection station  $\text{IS}$ ,

$$V_{K+\text{IS}} = \frac{N_{K+\text{IS}}}{C_{K+\text{IS}} C_{K+\text{IS}+1} \dots C_{K+\text{NS}}}.$$

The adjusted visit ratio  $V_i$ ,  $i = 1, \dots, K + \text{NS}$ , can also be viewed as the ratio of the mean arrival rate at node  $i$  (machine or inspection station) of the system to the rate of satisfied demand or system throughput. This is also in accordance with our assumption that the adjusted visit ratio of the equivalent machine  $M_0$  is  $V_0 = 1$ .

Using the adjusted visit ratios and exact or approximate results from queueing theory, we can evaluate the performance of the CONWIP line. The most important performance measure of the system is its throughput  $\text{TH}$ .

Because the number of items in the system is always  $S$ , the system can be modeled as a closed queueing network of  $K + NS + 1$  queues with service rates  $\mu_i$ ,  $i = 0, 1, \dots, K + NS$ . The number of items in node  $i$  (queue + service) is denoted  $n_i$ . The quantity  $n_0$  is the number of finished products.

When the processing times of each node are independent, exponentially distributed random variables and the items at each machine and inspection station are processed according to a FIFO (first in, first out) discipline, the throughput of the system is given by (Buzen 1973)

$$TH = \frac{G(S-1)}{G(S)} \quad (14)$$

where

$$G(S) = \sum_{\substack{n_i \geq 0, \\ n_0 + \dots + n_L = S}} \left[ \prod_{i=0}^L \left( \frac{V_i}{\mu_i} \right)^{n_i} \right] \quad (15)$$

and  $L = K + NS$ . The rate of scrap items can be computed as follows. The yield rate,  $C = C_1 \dots C_K$ , is the fraction of raw items that become products. A fraction  $1 - C$  of raw items end up scrapped. Therefore, the total scrap rate is given by

$$SC = TH \frac{1-C}{C}. \quad (16)$$

There exist efficient algorithms to compute TH (Buzen 1973, Reiser and Lavenberg 1980). Other measures of performance, such as the mean number of items and the mean delay in each queue, can also be computed using these algorithms.

When the processing times have distributions other than exponential or they depend on the number of times an item has been reworked, and the service disciplines are not FIFO, throughput can be estimated with good accuracy using approximate methods (see, e.g., Narahari and Khan 1996). For systems with failure-prone machines, limited local buffers (with capacities less than  $S$ ) and multiple rework loops involving sequential

1  
2  
3  
4  
5  
6  
7  
8  
9  
10  
11  
12  
13  
14  
15  
16  
17  
18  
19  
20  
21  
22  
23  
24  
25  
26  
27  
28  
29  
30  
31  
32  
33  
34  
35  
36  
37  
38  
39  
40  
41  
42  
43  
44  
45  
46  
47  
48  
49  
50  
51  
52  
53  
54  
55  
56  
57  
58  
59  
60

operations, Li (2004) has proposed an iterative decomposition method to approximate TH. All these methods make direct or indirect use of  $N_i$  and  $V_i$  to compute routing probabilities and traffic intensities, assuming that the visit ratios are known. For systems with history-dependent rework routing, these quantities can be calculated using the results of sections 2.1 and 2.2.

Since there is always one inspection station at the end of the line, all products are conforming even when no additional inspection stations are installed. However, by adding more inspection points we can reduce the workload of downstream machines by preventing items that should have already been declared as scrap from being processed therein. The problem of inspection station allocation arises when it is costly and time-consuming to perform inspection at each stage of the production process. The ultimate criterion in deciding the best allocation is of course the mean profit rate of the system, which includes the profit from sales, the cost of scrap, inventory holding costs, and the costs of installing and operating inspection stations.

In the next section we give an example in which the problems of inspection station allocation and inventory control are solved simultaneously for a CONWIP line with exponential processing and inspection times.

#### 4. Inspection station allocation and inventory control of a CONWIP line

Consider a ten-machine CONWIP line with the following machine parameters: production rates  $\mu_i = 6$ , quality probabilities  $c_i = 0.9$ ,  $r_i = 0.09$ ,  $s_i = 0$  and  $t_i = 0.01$ ,  $i = 1, \dots, 10$ . The demand rate is  $\mu_0 = 4$ . The mean inspection times are integer multiples of 0.005, proportional to the number of operations in each chain. For example, if only one inspection station is installed, its mean production rate is  $\mu_{i1} = 1/(10 \times 0.005) = 20$  inspections per time unit. The system incurs a cost rate of 10 for each inspection station installed and for each machine whose output is inspected. Thus, if 2 inspection stations are installed, then the overall inspection cost rate is

1  
2  
3  
4  
5  
6  
7  
8  
9  
10  
11  
12  
13  
14  
15  
16  
17  
18  
19  
20  
21  
22  
23  
24  
25  
26  
27  
28  
29  
30  
31  
32  
33  
34  
35  
36  
37  
38  
39  
40  
41  
42  
43  
44  
45  
46  
47  
48  
49  
50  
51  
52  
53  
54  
55  
56  
57  
58  
59  
60

$2 \times 10 + 10 \times 10 = 120$ . Finally, the net profit from selling one product (unit selling price less price of raw item and production cost) is 300, the unit holding cost rate is 8, and the unit cost of scrap items is 20. The latter equals the cost of purchasing a raw item minus its salvage value.

Given the number NS of inspection stations, their chains, and the CONWIP inventory level  $S$ , we can calculate the adjusted visit ratios, yield rate, TH and SC following the analysis of the previous section. The mean profit rate,  $J$ , of the system is given by

$$J = 300TH - 20TH \frac{1-C}{C} - 8S - 10NS - 10 \times 10$$

where the first term is profit from sales and the others are cost of scrap items, inventory holding costs, fixed cost for NS inspection stations and variable inspection cost for 10 machines.

To maximize  $J$  we perform an exhaustive evaluation of inspection station allocations using the following

**Algorithm 2:**

1. Initialize the maximum profit rate  $J^* = 0$ . Initialize the allocation of inspection stations, setting  $NS = 1$  (in this case, all machines belong to chain 1).
2. Compute the yield rate  $C$  and the visit ratios  $V_i, i = 1, \dots, K + NS$ , for the current allocation of inspection stations.
3. For  $S = 1, 2, \dots$ , compute  $G(S)$ , TH and SC from equations (15)–(17) and the component of the profit rate

$$f(S) = \frac{G(S-1)}{G(S)} \left( 300 - 20 \frac{1-C}{C} \right) - 8S.$$

If  $f(S) < f(S-1)$  for some  $S \geq 2$ , then the optimal CONWIP level for the current allocation is  $S-1$  with corresponding profit rate

$$J = f(S-1) - 10NS - 100.$$

4. Keep the maximum profit rate  $J^*$  along with the corresponding allocation and CONWIP level in the memory: if  $J > J^*$ , set  $J^* = J$ .
5. Generate another allocation of inspection stations and go to step 2. Repeat until  $NS = 10$ , in which case each machine has its own inspection station. If  $J^* = 0$ , then the system is not profitable.

Step 3 of the algorithm gives the optimal CONWIP level for any fixed allocation of inspection stations. This is justified as follows. Maximizing  $J$  with respect to  $S$  is equivalent to maximizing  $f(S)$ . The function  $G(S - 1)/G(S)$  is concave and increasing (Shanthikumar and Yao 1988) for a class of closed queueing networks including systems with constant processing rates, as the CONWIP line studied herein. The coefficient  $300 - 20(1 - C)/C$  in  $f(S)$  is positive or negative. If it is positive, then  $f(S)$  is concave and, therefore, the smallest value  $S - 1$  for which  $f(S) < f(S - 1)$  is the globally optimal value; otherwise,  $f(S)$  negative and decreasing, so the optimal nonzero CONWIP level is 1.

Table 1 shows the optimal arrangement of inspection stations and the corresponding CONWIP levels and profit rates for  $NS = 1, \dots, 10$ . The location of each inspection station is described by the index of the last machine in the chain.

<b>insert Table 1 about here</b>
----------------------------------

In all cases, there is always one inspection station after the last machine  $M_{10}$ . We see that installing just one more inspection station in the middle of the line maximizes the profit rate. If we double the probabilities of scrapping and rework, then a maximum profit rate of 542.8 is achieved when three inspection stations are located after machines 3, 6 and 10, and for CONWIP level  $S = 29$ . For a twenty-machine system with the original

1  
2  
3  
4 parameter values, the optimal design achieves a profit rate of 360.2 and  
5 involves three inspection stations located after machines 6, 13 and 20, and  
6 CONWIP level  $S = 38$ .  
7  
8

9  
10 Since there is always an inspection station at the end of the line, the  
11 number of different allocations is  $2^{K-1}$ , where  $K$  is the number of machines.  
12 Algorithm 2 requires about 220 seconds on an Intel® Core™ 2 Duo  
13 1.33GHz processor to evaluate possible designs for the 20-machine  
14 CONWIP line. The CPU time is roughly doubled for each additional  
15 machine.  
16  
17

18 To design larger systems with reasonable computational effort other  
19 methods that avoid exhaustive search must be developed. A greedy  
20 approach is to start with  $NS = 1$  and increase the number of stations one at a  
21 time until  $J$  starts to decrease. This approach gives the optimal design when  
22  $J$  is a concave or unimodal function of  $NS$ . For example, for the 10-machine  
23 line whose results are shown in Table 1 and for the other two experiments  
24 discussed above, the profit rate is unimodal in  $NS$  (although not concave) in  
25 the sense that it has a single local (and, therefore, global) maximum.  
26 However, despite the experimental evidence, because unimodality is not  
27 established for the general case, the greedy algorithm may not converge to  
28 the optimal design. Genetic search algorithms may be used to deal with the  
29 presence of multiple local optima.  
30  
31  
32  
33  
34  
35  
36  
37  
38  
39  
40  
41  
42  
43  
44  
45

## 46 5. Conclusions

47 We have conducted a workflow analysis of production lines with quality  
48 inspection stations located at intermediate stages of the production process.  
49 Each inspection station inspects all items that complete a specific chain of  
50 consecutive operations. An operation can be conforming, repairable,  
51 reworkable, or unacceptable. Conforming items continue to the next chain  
52 of operations. Repairable items are processed locally (off-line) and become  
53 conforming. Reworkable items are sent back for rework to the  
54  
55  
56  
57  
58  
59  
60

1  
2  
3  
4  
5  
6  
7  
8  
9  
10  
11  
12  
13  
14  
15  
16  
17  
18  
19  
20  
21  
22  
23  
24  
25  
26  
27  
28  
29  
30  
31  
32  
33  
34  
35  
36  
37  
38  
39  
40  
41  
42  
43  
44  
45  
46  
47  
48  
49  
50  
51  
52  
53  
54  
55  
56  
57  
58  
59  
60

corresponding machines which performed the defective operations. Disposable items are replaced by new raw items, which are released into the first machine of the production line. For each operation, the probabilities of the various types of quality failures may depend on the number of times this operation has already been performed on the same item. Using these probabilities, we derive expressions for the mean workload intensity of each machine and each inspection station per conforming end item. This information, combined with queueing network formulas, is used to optimally allocate inspection stations and determine the inventory control policy for a make-to-stock production line with random demand.

The analysis presented herein can be extended in several directions.

Inspection errors, concerning conforming items classified as nonconforming and vice versa, can be incorporated into the probabilities of scrap and conforming items. In this case, the expressions derived need modifications to take into account additional rework loops which emanate from the points at which the errors of previous inspections are detected. If the inspection errors involve only conforming items mistaken scrap, then this can be taken into account by increasing the probabilities of nonconforming operations by the corresponding error and decreasing the probabilities of conforming operations by the same amount; thus, no additional rework loops are needed for this type of error.

Random inspection, where only a fraction of items are inspected, could also be incorporated. As previously, modifications are needed for additional rework loops from the points at which previously undetected errors are discovered.

Reworkable operations may require shorter processing times than the original operations of the same type. Also the processing times may not be exponential random variables and machines may have local buffers of limited capacity. Finally, queueing disciplines other than FIFO could be considered. All the above generalizations can be taken into account using approximate queueing analysis or decomposition methods (Kim *et al.* 1995,



1  
2  
3  
4  
5  
6  
7  
8  
9  
10  
11  
12  
13  
14  
15  
16  
17  
18  
19  
20  
21  
22  
23  
24  
25  
26  
27  
28  
29  
30  
31  
32  
33  
34  
35  
36  
37  
38  
39  
40  
41  
42  
43  
44  
45  
46  
47  
48  
49  
50  
51  
52  
53  
54  
55  
56  
57  
58  
59  
60

Narahari and Khan 1996, Li 2004, Pradan and Damodaran 2008).

## References

Britney, R.R., 1972. Optimal screening plans for nonserial production systems. *Management Science*, **18**, 550–559.

Buzen, J.P., 1973. Computational algorithms for closed queuing networks with exponential servers. *Communications of the ACM*, **16**, 527–531.

Crowley, D.J., Bard, J.F. and Jensen, P.A., 1995. Using flow ratio analysis and discrete event simulation to design a medium volume production facility. *Computers and Industrial Engineering*, **28**, 379–397.

Eppen, G.D. and Hurst, F.G., 1974. Optimal location of inspection stations in a multistage production process. *Management Science*, **20**, 1194–1200.

Ioannidis, S., Kouikoglou, V.S. and Phillis, Y.A., 2004. Coordinating quality, production, and sales in manufacturing systems. *International Journal of Production Research*, **42**, 3947–3956.

Kim, J., Schweitzer, P.J. and Seidmann, A., 1995. Analysis of flexible manufacturing systems with distinct repeated visits: DrQ. *International Journal of Flexible Manufacturing Systems*, **7**, 319–338.

Lee, H.S., Frein, Y. and Duri, C., 1999. Performance evaluation of a flow line system with Bernoulli sampling inspections. *International Journal of Production Research*, **37**, 581–595.

Li, J., 2004. Throughput analysis in automotive paint shops: a case study. *IEEE Transactions on Automation Science and Engineering*, **1**, 90–98.

Lindsay, G.F. and Bishop, A.B., 1965. Allocation of screening inspection effort: A dynamic programming approach. *Management Science*, **10**, 342–352.

Mandrolis, S.J., Shrivastava, A.K. and Ding, Y., 2006. A survey of inspection strategy and sensor distribution studies in discrete-part

- 1  
2  
3  
4 manufacturing processes. IIE Transactions, **38**, 309–328.
- 5  
6  
7 Morton, T.E. and Pentico, D.W., 1993. *Heuristic Scheduling Systems*, New  
8  
9 York: Wiley.
- 10  
11 Narahari, Y., and Khan, L. M., 1996. Modeling reentrant manufacturing  
12  
13 systems with inspection station. Journal of Manufacturing Systems, **15**,  
14  
15 367–378.
- 16  
17 Pradhan, S, and Damodaran, P., 2008. Performance characterization of  
18  
19 complex manufacturing systems with general distributions and job  
20  
21 failures. European Journal of Operational Research, **197**, 588–598.
- 22  
23 Rau, H, Chu, Y.-H., and Cho, K.-H., 2005. Layer modelling for the  
24  
25 inspection allocation problem in re-entrant production systems.  
26  
27 International Journal of Production Research, **43**, 3633–3655.
- 28  
29 Raz, T., 1986. A survey of models for allocating inspection effort in  
30  
31 multistage production systems. Journal of Quality Technology, **18**,  
32  
33 239–247.
- 34  
35 Reiser, M., and Lavenberg, S. S., 1980. Mean-value analysis of closed  
36  
37 multichain queuing networks. Journal of the ACM, **27**, 313–322.
- 38  
39 Seidman, A., and Nof, S. Y., 1985. Unitary manufacturing cell design with  
40  
41 random product feedback flow. IIE Transactions, **17**, 188–193.
- 42  
43 Shanthikumar, J. G., and Yao, D. D., 1988. Second-order properties of the  
44  
45 throughput of a closed queueing network. Mathematics of Operations  
46  
47 Research, **13**, 524–534.
- 48  
49 Spearman, M. L., and Zazanis, M. A., 1992. Push and pull production  
50  
51 systems: issues and comparisons. Operations Research, **40**, 521–532.
- 52  
53 Tapiero, C. S., and Hsu, L.-F., 1987. Quality control of the M/M/1 queue.  
54  
55 International Journal of Production Research, **25**, 447–455.
- 56  
57 White, L. S., 1969. Shortest route models for the allocation of inspection  
58  
59 effort on a production line. Management Science, **15**, 249–259.
- 60 Wittrock, R. J., 1992. The "Orchard" scheduler for manufacturing systems.

1  
2  
3  
4  
5 International Journal of Production Economics, **28**, 47–70.  
6

7 Yum, B. J., and McDowell, E. D., 1981. The optimal allocation of  
8 inspection effort in a class of nonserial production systems. IIE  
9 Transactions, **13**, 285–293.  
10

11  
12 Yum, B. J., and McDowell, E. D., 1987. Optimal inspection policies in a  
13 serial production system including scrap rework and repair: an MILP  
14 approach. International Journal of Production Research, **25**, 1451–1464.  
15  
16  
17  
18  
19  
20  
21  
22  
23  
24  
25  
26  
27  
28  
29  
30  
31  
32  
33  
34  
35  
36  
37  
38  
39  
40  
41  
42  
43  
44  
45  
46  
47  
48  
49  
50  
51  
52  
53  
54  
55  
56  
57  
58  
59  
60

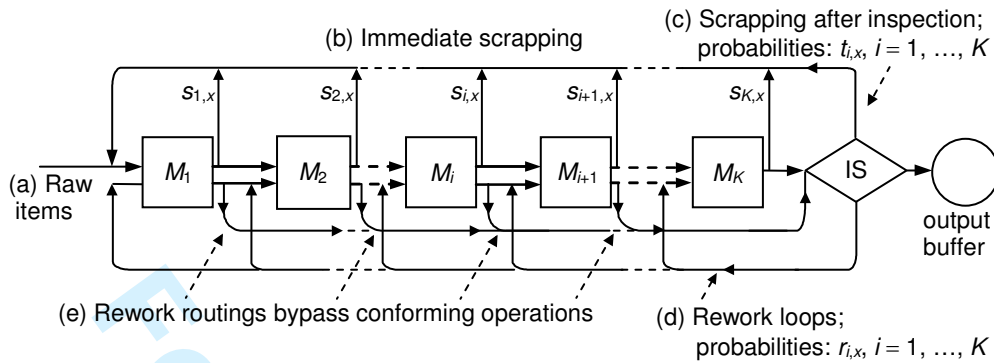

Figure 1. Flows in a production line with rough inspection at each stage and inspection and repair at end: (a) raw items; (b) items classified as nonconforming at the exit of each stage are scrapped and replaced by new raw items; (c) nonconforming items detected after inspection at IS are scrapped and replaced by raw items; (d, e) rework routings.

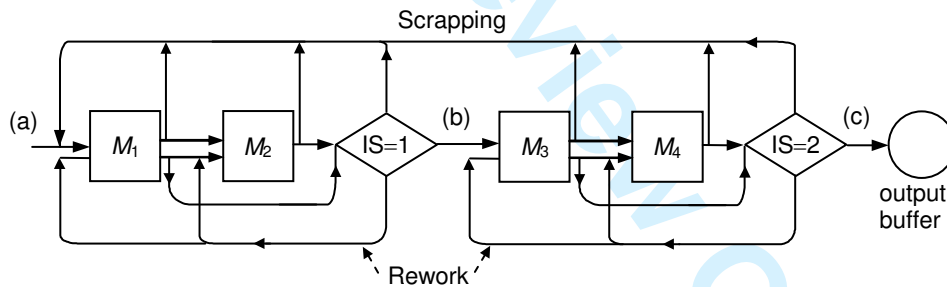

Figure 2. Flows in a production line with four machines and two inspection/repair stations: (a) raw items entering the chain of station IS = 1; (b) items entering the chain of station IS = 2; (c) conforming products.

Table 1. Optimal designs for various values of NS.

Number of stations		Optimal design		
NS	Location of inspection stations		<i>S</i>	<i>J</i>
1	10		30	707.3
2	5, 10		30	713.8
3	3, 6, 10		30	709.2
4	2, 4, 7, 10		30	701.9
5	2, 4, 6, 8, 10		30	693.6
6	1, 2, 4, 6, 8, 10		30	684.4
7	1, 2, 3, 4, 6, 8, 10		30	675.1
8	1, 2, 3, 4, 5, 6, 8, 10		30	665.8
9	1, 2, 3, 4, 5, 6, 7, 8, 10		30	656.4
10	1, 2, 3, 4, 5, 6, 7, 8, 9, 10		30	646.9