



**HAL**  
open science

## Structural morphology issues in free form design

Marine Bagnéris, René Motro, Bernard Maurin, N. Pauli

► **To cite this version:**

Marine Bagnéris, René Motro, Bernard Maurin, N. Pauli. Structural morphology issues in free form design. *International Journal of Space Structures*, 2008, 23 (2), pp.79-87. 10.1260/026635108785260560 . hal-00559728

**HAL Id: hal-00559728**

**<https://hal.science/hal-00559728v1>**

Submitted on 1 Oct 2024

**HAL** is a multi-disciplinary open access archive for the deposit and dissemination of scientific research documents, whether they are published or not. The documents may come from teaching and research institutions in France or abroad, or from public or private research centers.

L'archive ouverte pluridisciplinaire **HAL**, est destinée au dépôt et à la diffusion de documents scientifiques de niveau recherche, publiés ou non, émanant des établissements d'enseignement et de recherche français ou étrangers, des laboratoires publics ou privés.

# Structural Morphology Issues in Conceptual Design of Double Curved Systems

M. Bagneris<sup>1,\*</sup>, R. Motro<sup>1</sup>, B. Maurin<sup>1</sup>, and N. Pauli<sup>2</sup>

<sup>1</sup>Laboratoire de Mécanique et Génie Civil, UMR CNRS 5508, University Montpellier 2, Montpellier, France.

<sup>2</sup>Abaca Structural Engineering, Montpellier, France.

**ABSTRACT:** Non-standard architecture is generally defined by complex double curved systems. We described in this paper three morphogenesis processes. Analytic forms are mainly characterized by regular geometries like cylinders or spheres and portions of these geometric forms are present throughout the history of architecture. Mechanical forms appeared mainly during the second half of the twentieth century, under the impetus of pioneers like Frei Otto: these shapes are guided by an equilibrium condition, the expression of which is known as “form-finding”. Funicular, prestressed and self stressed systems are clearly in this second class. Initiated by the so-called “Bilbao effect” a new trend of double curved systems appeared, characterized by complete free forms that we name flexible forms. The objective is to analyse these classes of forms in relation with parameters of forces, material, technology and structural composition, which are coupled in the conceptual design process. We introduce mainly the coupling between form and structural composition (structural morphology). The last class reveals a lack of links between the parameters, and a complete dislocation of the successive steps of the design process. The evolution from analytical forms to flexible forms, via mechanically-constrained forms is examined in order to determine which constraints designers faced either due to their own choice or for other causes.

**Key Words:** Structural morphology, non-standard architecture, free-form design, morphogenesis.

## 1. INTRODUCTION

Double-curved systems have been largely used in construction for a long time. If their typology was initially restricted to some classical shapes derived from the circle such as domes, a large field of new shapes has been investigated by designers mainly during the twentieth century with concrete shells, cable nets and membranes. In recent decades new architectural approaches emerged in the urban landscape. The Guggenheim Museum of F. O. Gehry, acknowledged to be one of the first realizations of “Blob” architecture because of the absence of orthogonality, transfigured the city of Bilbao. The

economic impact described as the so-called “Guggenheim effect” triggered off a big demand for this type of realisations.

Numerical tools have stimulated architects’ audacity for spatial representation and invite them to generate forms that were hitherto inaccessible through the simple use of ruler and compass. This results in geometrically complex projects which are driven by aesthetic intentions, without reference to classical building techniques. Considering the materialisation and realisation of such complex forms, questions associated with architectural, structural and constructive aspects make the emergence of an ideal compromise difficult.

\*Corresponding author email: bagneris@lmgc.univ-montp2.fr

It is a matter of fact that this freedom for forms during the conceptual design phase, may end up in very complex situations. Our objective is to understand morphogenesis through a conceptual reading where three families of forms may be identified in the organization of curved production in architecture. For some shapes, many parameters may be seen as coupled, essentially those associated to form and structural composition. For others, the predominance of the form results in a complete dislocation between numerous parameters. The necessity, and the difficulty, of meeting mechanical and morphological requirements are therefore revealed. A main challenge for builders is to avoid the associated drawbacks.

## 2. STRUCTURAL MORPHOLOGY

Any design process has to deal with multi-parametric problems. It could be then useful to identify the main parameters and to classify them so as to understand simultaneously the degrees of freedom, the variables for the designer, which can be alone, or associated. As far as engineering problems are concerned, five classes of parameters may be considered [1], namely (Fig.1):

- **Form:** This can be the form of every component or of the whole system. Geometric information of size and position are generally sufficient, but many others can be useful for the description of double curved surfaces (curvature radii for instance).
- **Force:** "Force" is the generic word for description of the mechanical characteristics of actions, stresses, prestress, strains, deflections...
- **Structure:** understood in its systemic meaning, this describes the component's assembly and the boundary conditions selected by the designer. It could also be called the *relational structure* of the system.
- **Material:** This is related to mechanical behaviour of the used material as a result of experimental testing giving access to characteristics like young modulus, yield stress...
- **Technology:** Since the building requirements are generally pre-eminent during the design process, all associated technological aspects are included in this class of parameter.

People who are involved in Structural Morphology studies, mainly on the coupling between form and structure, try to optimize the resulting building in terms of mechanical behaviour. Many recognize engineers have underlined the pre-eminent role of form in their design process.

The parameters can be more or less coupled. The study of their relationships and couplings aims at

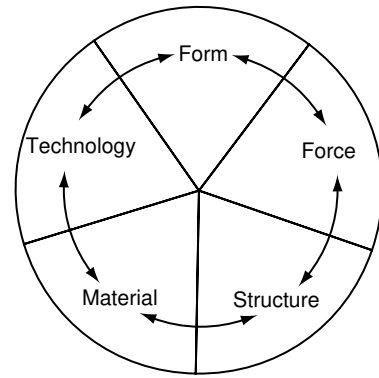

Figure 1. "Form-force coupling" conceptual scheme.

identifying common denominators and therefore at revealing families of forms. The present non-standard architecture is mainly characterized by double-curved surfaces. It may be useful to know more about the evolution of constraints for these surfaces, before trying to deal with some landmarks for actual complex shapes in order to introduce simplicity into the actual complexity. Three main classes can be identified: analytic forms, mechanically-constrained forms and flexible forms.

## 3. FROM ANALYTIC TO FLEXIBLE FORMS

### 3.1. Geometrically-constrained forms or "analytic forms"

The authors, arbitrarily, call "analytic" those forms which are only conditioned by a geometrical definition. These are forms resulting from geometrical operations achieved on the basis of simple surfaces like cylinders, spheres, ellipsoids, and all surfaces created by directing and generating lines. Most are quadratic surfaces, the simplest after the plan. They have been used in constructions to properly generate double curvature because they are ruled or of revolution.

#### 3.1.1. Arches, vaults and domes

These forms may be seen as constrained either by technological requirements, and or by geometrical generation. Barrel vaults and domes can be inserted in this class. Derived from the circle, their form leads to a surface of revolution easy to draw, but also to build if we do not take into account the difficulties when large scales are envisaged (Fig.2). The history of architecture provides many examples of innovative solutions. P. Brunelleschi's works, have integrated from the beginning of the shape study, materials, technology and structural behaviour in one single process, also based on results of experimental full scale tests of an eighth-scale model of the project. The



Figure 2. Pantheon, Roma, Italy, IInd century.

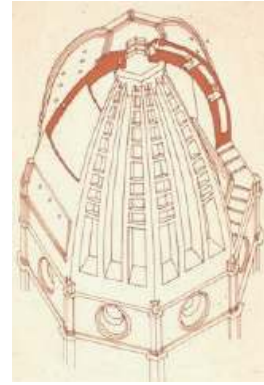

Figure 3. Santa Maria del Fiore, Firenze, Italy, XV<sup>th</sup> century.

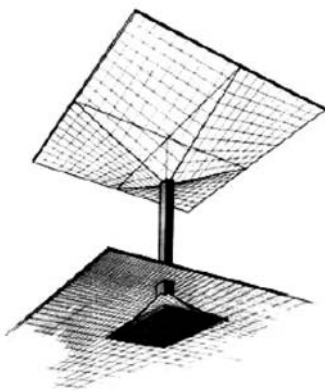

Figure 5. F. Candela's hyperbolic paraboloid shell, 1953.

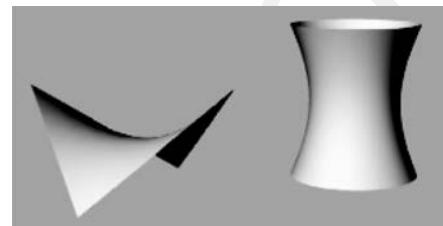

Figure 4. Classical ruled surfaces.



Figure 6. Cable net dry cooling tower, Schlaich Bergemann & Partners, 1974.

double-layer shell concept was certainly born with Santa Maria del Fiore Cupola (Fig.3).

### 3.1.2. Ruled surfaces

Negative Gaussian curvature surfaces can be designed and built on the basis of straight lines. Such surfaces are known as ruled surfaces (Fig.4). For reinforced concrete

shells, the false work is then simple to realize; it has been largely used by F. Candela (Fig.5), despite the significant number of workers required for their construction. The principle is based on two straight lines as directing lines, with another generating line resting on the two first to constitute hyperbolic paraboloid surfaces. An inclined generating straight line resting on two circles end up in a one-sheet hyperboloid of revolution; hyperboloids, and portions of hyperboloids have been often used in shell morphogenesis.

Several cooling towers have also been designed using this geometric property. Since prestressed cables are straight (at first order), it is not surprising that designers like Schlaich and Bergemann have built cooling towers in hyperboloid form with cables as generating lines (Fig.6).

### 3.1.3. Further with numerical models

Thanks to geometrical tools, it is possible to use simultaneously analytic forms of higher degree than quadratics and their combinations to define new shapes. Bradshaw's approach illustrates this process by generating shells derived from intersecting tori [2]. Another illustration has been given by the lens of the Saint Lazare metro station in Paris [3]. The shape of the envelope is generated by combining spherical segments over a torus. Three stages may be identified to clearly understand the geometry:

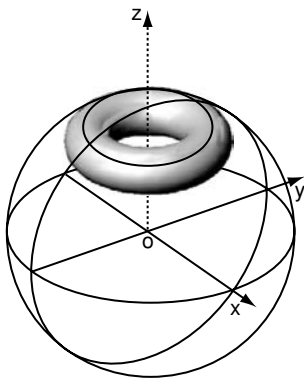

Figure 7-a. Geometrical generation of the surface.

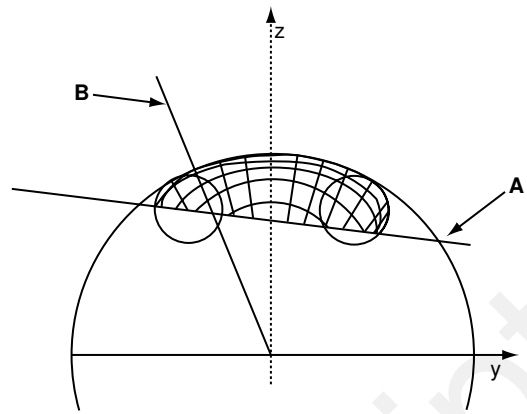

Figure 7-b. Square mesh generation.



Figure 7-c. St. Lazare Metro Station, Paris, France, 2004.

- Firstly, a torus is designed. Then, a sphere is plotted having a tangency with the torus. The intersection is a circle (Fig.7-a). We obtain a spherical dome over a torus.
- To delimit the final surface, an inclined plane named A intersect the torus part (Fig.7-b).
- The square mesh is the result of the intersection of multiple radial planes with the resulting surface. One of them, named B is illustrated in Fig. 7-b.

The result looks like a water drop (Fig.7-c) but remains a geometry of revolution. The square grid composed by the great circle, geodesic lines of the sphere, is projected from the plane A to the envelope to orient the structural arcs. Due to the geometrical properties of geodesic lines, the arcs are orthogonal to the spherical part of the envelope which is not the case with the torus part where their inclination varies from point to point. The geometrical logic allows the engineers to clearly identify a main technological issue: the connection between the skin and the primary

structure. A self-aligning spherical joint is consequently used to absorb the angle of inclination of glass panels with regard to the structure. The force parameter is classically handled: the worst loading case dimensions the laminated annealed glass panels while the maximum strains of the bending arcs located on the torus side are managed by a varying moment of inertia stainless steel profile. A total number of 108 doubly-curved panels glazes the skin; 36 of which are unique and some interesting properties of symmetry for the others reduce the number of moulds.

The structural morphology schema (Fig.7-d) shows the design parameters which are associated, helping the transmission between the project's partners. It is interesting to note that this design was realized by RFR, the office founded by P. Rice, who was involved in the design of the shells of Sydney Opera House. In the case of the lens, one is at a crossing point between "analytic" form (the sphere and the torus) and the numerical potential of computers for projecting the square grid and sizing curved glass panels.

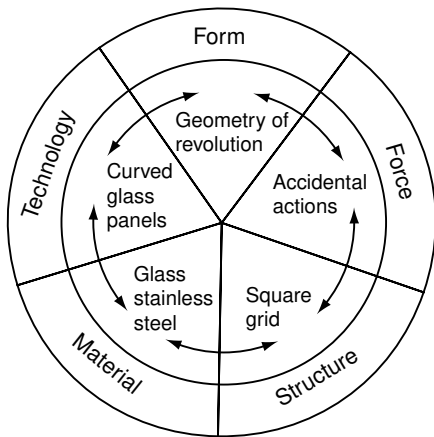

Figure 7-d. Conceptual scheme.



Figure 8-a. Gazoline station, Deitingen, Switzerland, 1968.

### 3.2. Mechanically-constrained forms or "mechanical" forms

#### 3.2.1. Introduction

When there is a strong relationship, between the forms and the actions, it can be said that the shapes are "mechanically-constrained". For those constructions a new step is necessary during the design process, the form-finding one, which aims to define the geometry that ensures a stable static equilibrium.

According to the mechanical conditions, resulting constructions can be denoted as funicular, prestressed or selfstressed. If dedicated software can model the form and force coupling in a resulting equilibrium, physical models can also be generally a more pleasant shape, namely in terms of results, and of form control.

#### 3.2.2. Funicular shapes

If Poleni was one of the first to use the principle of funicular forms under a given set of loads (in his study of cracking in the dome of St Peters, in Rome), A. Gaudi appears to be a pioneer for designing compressed structures by the reverse hanging method that generates funicular shapes [4]. Another famous designer, H. Isler has developed experimental form-finding processes for designing his wonderful concrete shells (Fig.8-a): the reverse hanging method based on fabric immersed in a

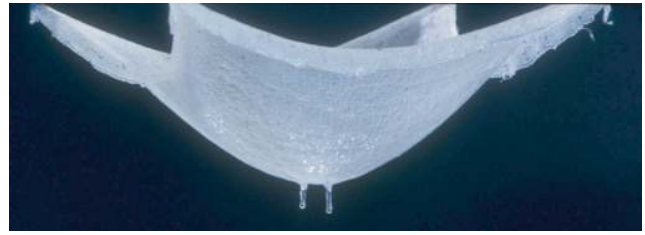

Figure 8-b. Form-finding process.

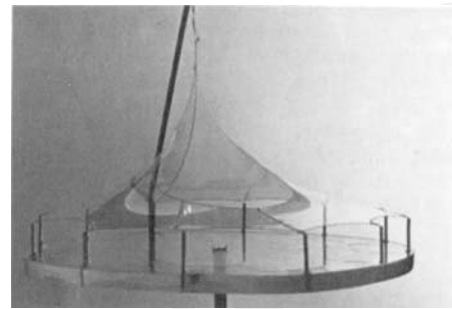

Figure 9. Form-finding process.

polymerized resin (Fig.8-b), and inflated membrane (which can be considered as funicular, under the internal pressure). It is noticeable that, in the first case, the edges of the fabric frequently end up in curves that rigidify the shell, but this can be avoided for design purpose.

#### 3.2.3. Prestressed and selfstressed shapes

When double-curved cable nets or membranes are prestressed by means of masts, edge cables, and also with reinforced concrete foundations ensuring the total equilibrium, their mechanical behaviour depends on this prestress. The most popular systems have been designed by Frei Otto, and among them the Institute of Lightweight Structures building itself, in Stuttgart. Form-finding of prestressed systems is now achieved by numerical methods like the force density method [5] or dynamic relaxation [6]. Physical models were initially used, taking advantage of minimum area surfaces that can be generated with soap films (Fig.9). Selfstressed shapes are just mentioned for sake of clarity, even if the corresponding systems are not so familiar. Indeed, they have never really left the "art world" due to the difficulty of cladding such structures. Studies have however shown that it is for instance possible to design double-curved tensegrity systems (Fig.10).

The structural morphology schema has been applied to the fabric membrane Marsyas (Fig.11-a) realised by A. Kapoor in the London Tate Modern. The sculpture comprised three steel rings connected together by a single span of PVC fabric. One ring was anchored



Figure 10. Positive double curvature tensegrity grid.



Figure 11-a. Marsyas, London, England, 2002. © Tate Photography.

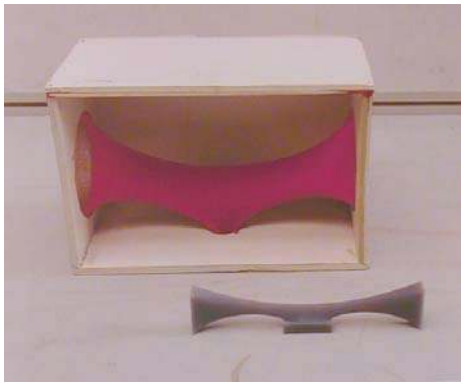

Figure 11-b. Marsyas's form-finding process.



Figure 11-c. Cutting pattern.

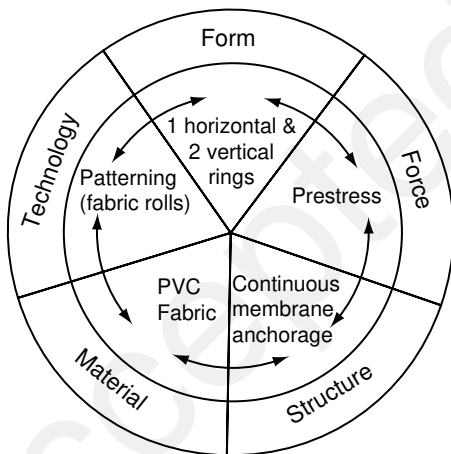

Figure 11-d. Conceptual scheme.

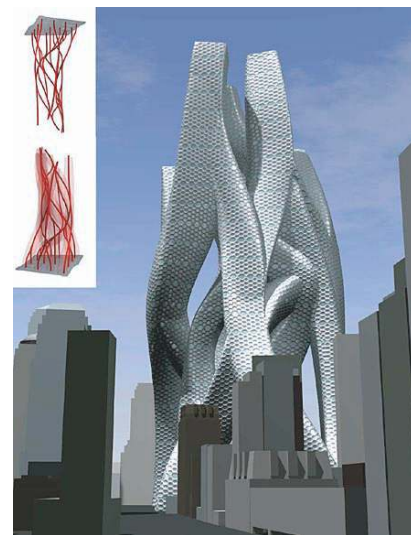

Figure 12. Oblique World Trade Center, Nox New York, USA, 2001.

horizontally while two others were vertically anchored at each end of the Turbine Hall. The use of prestress enhanced the form-force coupling (Fig.11-b) while the necessity of an aesthetic cutting pattern (Fig.11-c) created an additional link between this coupling, the technological and material parameters (Fig.11-d).

### 3.3. "Flexible" forms

It is a fact that designers are now in a new architectural era, which is characterized by the appearance of shapes which meet no previous criteria (Fig.12) in terms of regularity, orthogonality, planarity...etc.



Figure 13-a. MARTa Herford Museum, Herford, Germany, 2004, © T. Mayer.



Figure 13-b. Structural pattern, © T. Mayer.

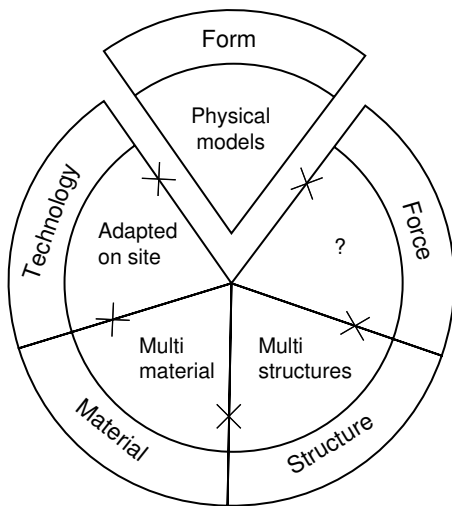

Figure 13-c. Conceptual scheme.

Free forms, flexible forms, blob architecture, digital architecture, whatever they may be called are rich in terms of morphology but with a high degree of complexity. It is worth noting that if they appear in a “digital” predominantly context, their shapes may sometimes result from a multiplicity of physical models. The flexible forms are mainly characterized by portions of double-curved surfaces. But this is only their formal aspect and is only a geometrical characterization. Problems occur when the mechanical behaviour, and moreover, technological solutions have to be handled. Engineers have to solve difficult problems, which can end in “nightmares”.

The case of the MARTa Herford Museum (Fig.13-a) designed by F. O. Gehry illustrates a particular focalisation on the form and the visual performance. Because the shape is outside any standard building form, or building recommendations, pertinent loadings cases are difficult to identify. The flexible form geometry born from the imagination of the architect is not formulated into an efficient model to calculate. Consequently, the skin must be completely supported

by an independent steel structure. The structural parameter and the whole design process become extremely complex, and even chaotic (Fig.13-b). Even if the skin is made of high-strength materials, its mechanical properties are not employed in the global structural behaviour. Thus, separate structure and cladding have to be used. Such complications entail many unknowns for the technological responses. This kind of project fully involves the knowledge of the associated enterprises which often have to develop processes specially adapted to the project. The links between parameters are somewhat “broken” during the design process, which emphasizes the form parameters described by the physical models, to the detriment of the others (Fig.13-c).

### 3.4. How can one weave links between the forms and their realization?

The five families of parameters, mentioned above, are nevertheless insufficient to describe a building, since many non-geometrical characters linked to architecture, in its complex meaning are not described. But it is interesting to understand that these parameters are closely coupled in the design process and are related to the information transfer between the partners from the initial design intention to the final realization. It is then obvious that the transfer of information can suffer from distinct ways of thinking. If we believe B. Lawson who claims that “architects are much more reliant on experiential” knowledge “while most professions rely extensively on theoretical” knowledge [7], there are two distinct ways because there are used at different levels of expertise. At the crossing point, when all the partners are obliged to join each other to go further, comprehension problems arise.

Therefore an interesting question could be related to the evolution of the mutual understanding between partners according to the three kinds of shapes which have been presented in the preceding paragraphs.





Figure 14-a. Guggenheim Museum, Bilbao, Spain, 1997.

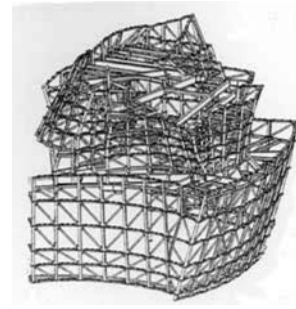

Figure 14-b. Structural composition.



Figure 15-a. Centre Pompidou, Metz, France, 2006-2009.



Figure 15-b. Structural composition.

The “analytic” forms mastered for ages by architects resulted either from drawing tools or buildings possibilities. Recently one of us could see in the Sagrada Familia a simple piece of wood batten with two nails, which was claimed as a “compass”, and it was effectively a pertinent drawing tool for this construction site: the simplest way to draw a circle. This simplicity allowed people in charge of design to model the shapes with an “analytical language” taking advantage of the basis of analytical geometry. Indeed, even if the partners do not use the same language of representation, their respective tools aim at avoiding any confusion in the final result. The link between “experiential” and “theoretical” knowledge is possible for this first class of curved forms, but nowadays this morphological vocabulary is partly exhausted. If we pay attention to shell shapes, both ways are illustrated by the works of H. Isler and M. Mihailescu. Morphogenesis result from physical experiments for the former and from shapes which can be described by analytic equations by the later. It is a fact that for some

cases the analytic equations could be easily transformed for their implementation into equations of mechanical behaviour. But designers, like Isler, expected more freedom in the register of forms and they did not restrain their inspiration in the limited field of analytical shapes.

The “mechanically-constrained” forms require either serious interest in the form-finding process or theoretical knowledge of non-linear static equilibrium. The major realizations came from the imagination of famous pioneers able to handle a difficult generation process. They do not control the totality of the shape but only some parts, essentially those related to the boundary conditions. Thus, without mechanical knowledge to improve the possibilities, the results range in a restricted family of solutions and lack of flexibility.

Actually, designer’s interest is clearly oriented toward the universe of “flexible” forms which may or may not keep the stated couplings between form and other parameters. A decade separates the two designs

presented below: the Guggenheim Museum by F.O. Gehry and Partners (Fig.14-a&b), and the Pompidou Centre in Metz by S. Ban (Fig.15-a&b). Obviously, the Guggenheim does not depend on a specific technology of realization. This design is the result of how classical technical solutions have been handled to obtain a new aesthetic. The Pompidou's structural composition displays an evolution. The integration of the design parameters have been better grasped to model the mechanical behaviour and to find the technical solutions for the realization...which, however, does not exclude the difficulty of the attainment!

These "flexible forms" are a source of complexity and also of disagreement between the partners. The challenge is to weave coherent links between the "skin" and the supporting "structure", and perhaps to design a self sustaining "skin", so as to keep the morphologic richness while simplifying simultaneously the design studies and the construction process.

#### 4. CONCLUSION

Double-curved systems have existed since the beginning of building history. In this paper we classified these double curved systems into three classes called "analytic", "mechanical" and "flexible" forms. We paid attention to this last class, because of its complexity and of the dislocation occurring between the different steps of the design process. This last denomination covers non-standard architecture symbolized by the Guggenheim Museum in Bilbao. Being at the boarder line between sculpture and architecture the new shapes do not take into account the structural requirements: engineers have to find solutions without any continuity between form and structural aspects. The pertinence of structural morphology could have no meaning in this non standard architecture, unless new morphological tools appear. A large range of studies is open to facilitate the design process. The necessity to simplify this complexity meets the emergence of new methods of shape description. Among the possible simplifications, it is necessary to have adapted geometrical tools which could simultaneously enable the generation of complex forms and to keep the coupling between geometry and physics of the generated form.

More than four decades ago, the car industry was already involved in considering fashionable shapes elaborated by their designers. So, this industrial sector

was confronted earlier with the issue of design process optimisation. It is worth recalling Pierre Bézier's quotation [8], when he was working for Renault in the 1960's, since it may be applied now to the building industry without anachronism:

*" (...) it seemed to me that it would be necessary to manage to use an unquestionable definition, exempt of distorsion and easy to communicate, established by the very fashion designer and transmitted then under numerical form in all groups, including outside contractors and purveyors, intervening in process, since the designer up to the inspector operating at the exit of the production line, and even at the workshops of maintenance of the network of the agents and the concessionaires"*

#### 5. ACKNOWLEDGMENTS

A special mention should be made to the ANRT, the engineering office AbAcA and the région Languedoc-Roussillon which financially support this work.

#### REFERENCES

- [1] Motro R., *Structural Morphology*, Journal of the International Association for Shell and Spatial Structures, Special Issue 7 papers, Vol. 34, n° 113, 1993.
- [2] Bradshaw R., Campbell D., Gargari M., Mirmiran A., Tripeny P., *Special Structures: Past, Present, and Future*, Journal of structural engineering, June 2002.
- [3] Baldassini N., *Glass and Geometry*, Glass Processing days, 2005.
- [4] Tomlow J., *Das Modell. The model. El Modelo*, IL 34, 1989, Institute of Lightweight Structures, University of Stuttgart, Editor Frei Otto.
- [5] Sheck H.J., The force density method for form-finding and computation of networks, *Computer methods in applied Mechanics and Engineering* 3, pp.115–134, 1974.
- [6] Barnes M.R., Wakefield D.S., Dynamic relaxation applied to form finding and analysis of tension structures, *Proc. Int., Conf., on Air Supported Structures*, Bristol, pp.1–13, 1984.
- [7] Lawson B., *Oracles, draughtsmen, and agents: the nature of knowledge and creativity in design and the role of IT*, *Automation in construction*, Vol. 14, pp.383–391, 2005.
- [8] Rabut C., *On Pierre Bézier's life and motivations*, *Computer-aided design*, Vol.34, pp.493–510, 2002.

#### Photographic references:

Fig.11-a: <http://www.tate.org.uk/modern/exhibitions/kapoor/-images.htm>

Fig.13-a & Fig.13-b: [http://thomasmayerarchive.de/categories.php?cat\\_id=683&l=english](http://thomasmayerarchive.de/categories.php?cat_id=683&l=english)