



**HAL**  
open science

## From High-Level Component-Based Models to Distributed Implementations

Borzoo Bonakdarpour, Marius Bozga, Mohamad Jaber, Jean Quilbeuf, Joseph  
Sifakis

► **To cite this version:**

Borzoo Bonakdarpour, Marius Bozga, Mohamad Jaber, Jean Quilbeuf, Joseph Sifakis. From High-Level Component-Based Models to Distributed Implementations. 10th International conference on Embedded software (EMSOFT 2010), Oct 2010, Scottsdale, AZ, United States. pp.209-218, 10.1145/1879021.1879049 . hal-00557792

**HAL Id: hal-00557792**

**<https://hal.science/hal-00557792>**

Submitted on 16 May 2024

**HAL** is a multi-disciplinary open access archive for the deposit and dissemination of scientific research documents, whether they are published or not. The documents may come from teaching and research institutions in France or abroad, or from public or private research centers.

L'archive ouverte pluridisciplinaire **HAL**, est destinée au dépôt et à la diffusion de documents scientifiques de niveau recherche, publiés ou non, émanant des établissements d'enseignement et de recherche français ou étrangers, des laboratoires publics ou privés.

# From High-Level Component-Based Models to Distributed Implementations\*

Borzoo Bonakdarpour  
Jean Quilbeuf

Marius Bozga  
Joseph Sifakis

Mohamad Jaber

VERIMAG  
Centre Équation  
2 avenue de Vignate, 38610  
Gières, France

## Abstract

*Constructing correct distributed systems from their high-level models has always been a challenge and often subject to serious errors because of their non-deterministic and non-atomic structure. Thus, it is highly desirable if designers can automatically transform high-level models (where high atomicity is assumed through global state semantics and distribution details are omitted via employing high-level synchronization primitives) into implementations in a systematic and correct fashion. In this paper, we propose such a transformation in the context of the BIP modeling formalism [5]. Our transformation preserves observational equivalence and allows parallelism between components even though these components interact through multi-party synchronization primitives in the corresponding high-level model. In particular, our method, (1) transforms a high-level BIP model into another BIP model that operates using asynchronous message passing, (2) constructs a set of distributed schedulers, and (3) transforms the intermediate BIP model and schedulers into actual C++ distributed code. Our experiments show that the distributed code generated using our method exhibits close to ideal level of parallelism and communication overhead. We also illustrate that in some cases, the performance of the generated code is competitive with the performance of hand-written parallel code.*

**Keywords:** Component-based modeling, Automated transformation, Distributed systems, BIP, Correct-by-construction.

## 1. Introduction

Analysis and design of computing systems often starts with developing a high-level model of the system. Constructing models is beneficial, as designers can abstract away implementation details and validate the model with respect to a set of intended requirements through different techniques such as

formal verification, simulation, and testing. However, deriving a correct implementation from a model is always challenging, since adding implementation details involves many subtleties that can potentially introduce errors to the resulting system. In the context of distributed systems, these subtleties are magnified significantly because of inherently concurrent, non-deterministic, and non-atomic structure of distributed systems, as well as the occurrence of unanticipated physical and computational events such as faults. Thus, it is highly advantageous if designers can somehow derive implementations in a systematic and ideally automated correct fashion from high-level models. It is, nonetheless, unclear how to transform an abstract model (where high atomicity is assumed through global state semantics and distribution details are omitted via employing high-level synchronization primitives) into a real distributed implementation.

In this paper, we present a method to transform high-level models in BIP [5] into distributed implementations. The BIP (Behavior, Interaction, Priority) language is based on a semantic model encompassing composition of heterogeneous components. The *behavior* of atomic components is described as a Petri net extended by data and functions given in C++. Transitions of the Petri net are labeled by port names and functions computing data transformations when they are executed. BIP uses a composition operator for obtaining composite components from a set of atomic components. The operator is parametrized by a set of interactions between the composed components. An *interaction* is a strong synchronization (*rendezvous*) among a set of ports of the composed components. Thus, an interaction is *enabled*, if all of its participating ports are available. BIP has a formal operational semantics implemented by a *Scheduler* which coordinates execution of composite components by sequentially executing interactions. The Scheduler orchestrates the behavior of a composite component as follows:

- An atomic component can execute a transition labeled by a port only if it is notified by the Scheduler to do so. For this, it sends to the Scheduler the name of ports labeling its enabled transitions from a given state.

---

\*This work is sponsored by the COMBEST European project.

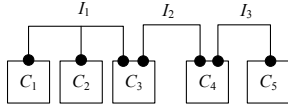

Figure 1. A simple high-level model.

- When the Scheduler receives the sets of enabled ports from all the atomic components, it computes the set of possible interactions, that is the set of interactions whose ports label only enabled transitions. The Scheduler then chooses one amongst the possible interactions and executes it. The execution of an interaction may involve data transfer between the interacting components followed by notification about its completion. The notified components can continue independently their computation.

In order to understand the subtleties of transformation from sequential models to distributed models, consider the BIP model in Figure 1. In this model, atomic components  $C_1 \cdots C_5$  synchronize through three rendezvous interactions  $I_1 \cdots I_3$ . In sequential models, interactions are executed atomically by a single scheduler. To the contrary, introducing concurrency and distribution (and possibly multiple schedulers) to this model requires dealing with more complex issues:

- (*Partial observability*) Suppose interaction  $I_1$  (and, hence, components  $C_1 \cdots C_3$ ) is being executed. If component  $C_3$  completes its computation before  $C_1$  and  $C_2$ , and,  $C_4$ 's port is available, then interaction  $I_2$  is enabled. In such a case, a distributed scheduler must be designed so that concurrent execution of interactions does not introduce behaviors that were not allowed by the high-level model.
- (*Resolving conflicts*) Suppose interactions  $I_1$  and  $I_2$  are enabled simultaneously. Since these interactions share component  $C_3$ , they cannot be executed concurrently. We call such interactions *conflicting*. Obviously, a distributed scheduler must ensure that conflicting interactions are executed mutually exclusive.
- (*Performance*) On top of correctness issues, a real challenge is to ensure that a transformation does not add considerable overhead to the implementation. After all, one crucial goal of developing distributed and parallel systems is to exploit their computing power.

We address the issue of partial observability by breaking the atomicity of execution of interactions, so that a component can execute unobservable actions once a corresponding interaction is being executed [4]. Resolving conflicts leads us to solving the *committee coordination problem* [9], where a set of professors organize themselves in different committees and two committees that have a professor in common cannot meet simultaneously. The original distributed solution to the committee coordination problem assigns one *manager* to each interaction [9]. Conflicts between interactions are resolved

by reducing the problem to the dining or drinking philosophers problems [8], where each manager is mapped onto a philosopher. Bagrodia [2] proposes an algorithm where message counts are used to solve synchronization and exclusion is ensured by using a circulating token. In a follow-up paper [3], Bagrodia modifies the solution in [2] by combining the use of message counts to ensure synchronization and reducing the conflict resolution problem to dining or drinking philosophers problems. Also, Perez et al [10] propose an approach that essentially implements the same idea using a lock-based synchronization mechanism.

As Bagrodia notes [3], a family of solutions to the committee coordination problem is possible, ranging over fully centralized to fully decentralized ones, depending upon mapping managers to the sets of committees. In the context of our transformation problem, each family of solutions results in a different implementation of the Scheduler. We classify these families into three broad categories:

- (*Centralized*) This category represents transformations where a concurrent model is managed by a single centralized scheduler (see Figure 2-a) no matter how the components are distributed.
- (*Partially decentralized*) This category refers to transformations where a set of schedulers collaborate in order to resolve conflicts in a distributed fashion (e.g., Figures 2-b and 2-c)). In addition to the solutions in [2, 3, 9], one can also reduce our problem in this category to distributed construction of an *independent set* (set of vertices that do not share an edge) of the graph whose vertices represent interactions and edges connect conflicting interactions. Thus, one can exploit solutions to distributed independent set in the literature.
- (*Fully decentralized*) This category represents solutions where each component acts as a partial scheduler and reaches an agreement with other components based on which non-conflicting interaction(s) can be executed (see Figure 2-d). In addition to the solutions in [2, 3, 9], other potential solutions to this category include algorithms for distributed graph (respectively, hypergraph) *matching*, i.e., a set of edges that do not share a common vertex, where each vertex represents a component and each edge represents a binary (respectively,  $n$ -ary) interaction.

We expect that each category of solutions exhibits advantages and disadvantages and, hence, fits a specific type of concrete applications on a target architecture and platform. For instance, multi-threaded systems running on a stand-alone platform managed by a central scheduler is an example of centralized solutions. A potential example of fully decentralized transformations is peer-to-peer file sharing applications, where execution of interactions requires significantly longer time than communication for scheduling.

Although the algorithms in [2, 3, 9] cover all the above categories, transforming a high-level model into a concrete distributed implementation involves other details that have to be taken into account. Examples include observational

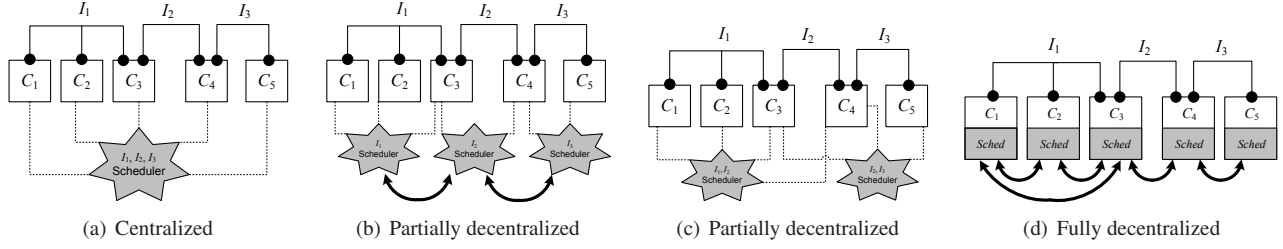

Figure 2. Spectrum of transformations.

equivalence, execution of the code associated with interactions and components, data transfer, maximum concurrency, fairness, fault-tolerance, combination of scheduling policies, efficiency, and performance. These issues can significantly change the dynamics and performance of a distributed implementation and each deserves rigorous research beyond the algorithms and preliminary simulations in [2, 3, 9]. We believe we currently lack a deep understanding of the impact of these issues and their correlation in transforming high-level models into concrete distributed implementations.

**Contributions.** With this motivation, in this paper, we propose a transformation from a high-level sequential BIP model into a distributed implementation that allows parallelism between components as well as parallel execution of non-conflicting interactions. Our method utilizes the following sequence of transformations preserving *observational equivalence*:

1. First, we transform the given BIP model into another BIP model that (1) operates in partial state semantics, and (2) expresses multi-party interactions in terms of asynchronous message passing (send/receive primitives).
2. We replace the Scheduler of the original model by a set of Schedulers, each handling a subset of conflicting interactions (e.g., Figure 2-c) - for maximal parallelism one Scheduler per interaction is needed.
3. We transform the intermediate BIP model into actual C++ code that employs TCP sockets for communication.

We also conduct a set of experiments to analyze the behavior and performance of the generated code. Our experiments show that depending upon the structure of the model, the distributed code generated using our method exhibits close to ideal level of parallelism and communication overhead. We also illustrate that in some cases, the performance of the generated code is competitive with the performance of hand-written code developed using the Message Passing Interface (MPI) [?].

**Organization.** In Section 2, we present the global state sequential operational semantics of BIP. Then, in Section 3, we present our BIP to BIP transformation. Section 4 describes transformation of the intermediate send/receive BIP model into C++ distributed code. Section 5 presents the results of our experiments. Finally, in Section 6, we make concluding remarks and discuss future work.

## 2. Basic Semantic Models of BIP

In this section, we present operational *global state* semantics of BIP. BIP is a component framework for constructing systems by superposing three layers of modeling: Behavior, Interaction, and Priority. Since the issue of priorities is irrelevant to this paper, we omit it.

**Atomic Components** We define *atomic components* as transition systems with a set of ports labeling individual transitions. These ports are used for communication between different components.

**Definition 1** (Atomic Component). *An atomic component  $B$  is a labeled transition system represented by a triple  $(Q, P, \rightarrow)$  where  $Q$  is a set of states,  $P$  is a set of communication ports,  $\rightarrow \subseteq Q \times P \times Q$  is a set of possible transitions, each labeled by some port.*

*For any pair of states  $q, q' \in Q$  and a port  $p \in P$ , we write  $q \xrightarrow{p} q'$ , iff  $(q, p, q') \in \rightarrow$ . When the communication port is irrelevant, we simply write  $q \rightarrow q'$ . Similarly,  $q \xrightarrow{p}$  means that there exists  $q' \in Q$  such that  $q \xrightarrow{p} q'$ . In this case, we say that  $p$  is enabled in state  $q$ .*

In practice, atomic components are extended with variables. Each variable may be bound to a port and modified through interactions involving this port. We also associate a guard and an update function to each transition. A guard is a predicate on variables that must be true to allow the execution of the transition. An update function is a local computation triggered by the transition that modifies the variables. Figure 3-a shows an atomic component  $B$ , where  $Q = \{s, t\}$ ,  $P = \{p, q, r\}$ , and  $\rightarrow = \{(s, p, t), (t, q, s), (t, r, t)\}$ .

**Interaction** For a given system built from a set of  $n$  atomic components  $\{B_i = (Q_i, P_i, \rightarrow_i)\}_{i=1}^n$ , we assume that their respective sets of ports are pairwise disjoint, i.e., for any two

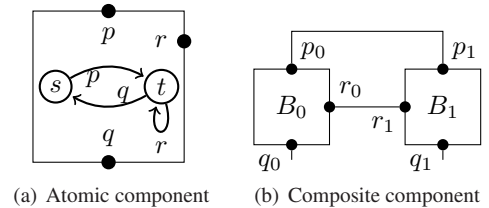

(a) Atomic component (b) Composite component

Figure 3. BIP composite component



$i \neq j$  from  $\{1..n\}$ , we have  $P_i \cap P_j = \emptyset$ . We can therefore define the set  $P = \bigcup_{i=1}^n P_i$  of all ports in the system. An *interaction* is a set  $a \subseteq P$  of ports. When we write  $a = \{p_i\}_{i \in I}$ , we suppose that for  $i \in I$ ,  $p_i \in P_i$ , where  $I \subseteq \{1..n\}$ .

As for atomic components, real BIP extends interactions by associating a guard and a transfer function to each of them. Both the guard and the function are defined over the variables that are bound to the ports of the interaction. The guard must be true to allow the interaction. When the interaction takes place, the associated transfer function is called and modifies the variables.

**Definition 2** (Composite Component). A composite component (or simply component) is defined by a composition operator parametrized by a set of interactions  $\gamma \subseteq 2^P$ .

$B \stackrel{def}{=} \gamma(B_1, \dots, B_n)$ , is a transition system  $(Q, \gamma, \rightarrow)$ , where  $Q = \bigotimes_{i=1}^n Q_i$  and  $\rightarrow$  is the least set of transitions satisfying the rule

$$\frac{a = \{p_i\}_{i \in I} \in \gamma \quad \forall i \in I. q_i \xrightarrow{p_i} q'_i \quad \forall i \notin I. q_i = q'_i}{(q_1, \dots, q_n) \xrightarrow{a} (q'_1, \dots, q'_n)}$$

The inference rule says that a composite component  $B = \gamma(B_1, \dots, B_n)$  can execute an interaction  $a \in \gamma$ , iff for each port  $p_i \in a$ , the corresponding atomic component  $B_i$  can execute the transition labeled with  $p_i$ ; the states of components that do not participate in the interaction stay unchanged. Figure 3-b illustrates a composite component  $\gamma(B_0, B_1)$ , where each  $B_i$  is identical to component  $B$  in Figure 3-a and  $\gamma = \{\{p_0, p_1\}, \{r_0, r_1\}, \{q_0\}, \{q_1\}\}$ .

### 3. Transformation from High-Level BIP to Send/Receive BIP

As mentioned in the introduction, the first step of our solution is an intermediate transformation from a high-level BIP model into a message passing BIP model. More specifically, we transform a composite component  $B = \gamma(B_1, \dots, B_n)$  in global state semantics with multi-party interactions into another BIP composite component  $B^{SR}$  in partial state semantics that only involves binary “Send/Receive” interactions. To this end, we transform each atomic component  $B_i$  into an atomic Send/Receive component  $B_i^{SR}$  (described in Subsection 3.1). We also add a set of atomic components  $S_1^{SR}, \dots, S_m^{SR}$  that act as schedulers. To this end, first, we describe how we build a centralized scheduler in Subsection 3.2. We construct the interactions between Send/Receive components in Subsection 3.3. Correctness of our transformation method is proved in Subsection 3.4. Finally, we replace the centralized scheduler by a set of distributed schedulers in Subsection 3.5.

**Definition 3.** We say that  $B^{SR} = \gamma^{SR}(B_1^{SR}, \dots, B_n^{SR})$  is a Send/Receive BIP composite component iff we can partition the set of ports in  $B$  into three sets  $P_s, P_r, P_u$  that are

respectively the set of send-ports, receive-ports and unary interaction ports, such that:

- Each interaction  $a \in \gamma^{SR}$ , is either a Send/Receive interaction  $a = (s, r)$  with  $s \in P_s$  and  $r \in P_r$ , or a unary interaction  $a = \{p\}$  with  $p \in P_u$ .
- If  $s$  is a port in  $P_s$ , then there exists one and only one receive-port  $r$ , such that  $(s, r) \in \gamma^{SR}$ . We say that  $r$  is the receive-port associated to  $s$ .
- If  $(s, r)$  is a send/receive interaction in  $\gamma^{SR}$  and  $s$  is enabled at some global state of  $B^{SR}$ , then  $r$  is also enabled at that state.

Notice that the second condition requires that only one component can receive a “message” sent by another component. The last condition ensures that every Send/Receive interaction can take place as soon as the sender is enabled, i.e. the sender can send the message immediately.

#### 3.1. Transformation of Atomic Components

Let  $B_i$  be an atomic component. We now present how we transform  $B_i$  into a Send/Receive atomic component  $B_i^{SR}$  that is capable of communicating with the scheduler. There are two types of Send/Receive interactions: *request* and *response*. A request interaction from component  $B_i^{SR}$  informs the scheduler that  $B_i^{SR}$  is ready to interact through a set of enabled ports. When the scheduler selects an interaction involving  $B_i^{SR}$  for execution, it notifies the component by a response interaction that includes the port chosen.

**Definition 4.** Let  $B_i = (Q_i, P_i, \rightarrow_i)$  be an atomic component and  $s$  be a state in  $Q_i$ . The request associated to  $s$  is the set of ports  $req^s = \{p \in P_i \mid s \xrightarrow{p} \cdot\}$ . We denote the set of all requests from  $B_i$  by  $REQ_i = \{req^s \mid s \in Q_i\}$ .

Since each response triggers an internal computation, following [4], we split each state  $s$  into two states, namely,  $s$  itself and a *busy state*  $\perp_s$ . Intuitively, reaching  $\perp_s$  marks the beginning of an unobservable internal computation. We are now ready to define the transformation from  $B_i$  into  $B_i^{SR}$ .

**Definition 5.** Let  $B_i = (Q_i, P_i, \rightarrow_i)$  be an atomic component. The corresponding Send/Receive atomic component is  $B_i^{SR} = (Q_i^{SR}, P_i^{SR}, \rightarrow_i^{SR})$ , where

- $Q_i^{SR} = Q_i \cup Q_i^\perp$ , where  $Q_i^\perp = \{\perp_s \mid s \in Q_i\}$ .
- $P_i^{SR} = P_i \cup REQ_i$  where, as we will see later,  $P_i$  are receive-ports and  $REQ_i$  are send-ports.
- For each transition  $(s, p, t) \in \rightarrow_i$ , we include the following two transitions in  $\rightarrow_i^{SR}$ :  $(s, p, \perp_t)$  and  $(\perp_t, req^t, t)$ .

Figure 4 illustrates transformation of the component in Figure 3-a into its corresponding Send/Receive component. Since there are two states in  $B$ , we have two request ports in  $B^{SR}$ : one for the request  $req^s = \{p\}$  and one for the request  $req^t = \{q, r\}$ .

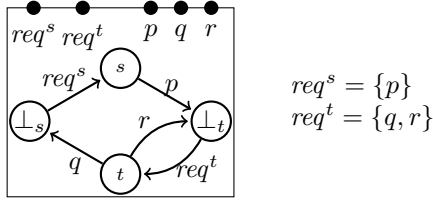

**Figure 4. Send/Receive atomic component of Figure 3-a.**

### 3.2. Building the Scheduler Component

In order to implement interactions, we add a new atomic component  $S$ , called the *scheduler component*. This component receives request messages sent by the Send/Receive atomic components. Based on the request messages received, the scheduler calculates the set of enabled interactions and selects one of them for execution. Then, it sends a response to each component involved in the selected interaction, so that they start their internal computations. Since we would like to allow local concurrency in the scheduler component, we define it as a Petri net.

**Definition 6.** A 1-Safe Petri net is defined by a triple  $S = (L, P, T)$  where  $L$  is a set of places,  $P$  is a set of ports and  $T \subseteq 2^L \times P \times 2^L$  is a set of transitions. A transition  $\tau$  is a triple  $(\bullet\tau, p, \tau^\bullet)$ , where  $\bullet\tau$  is the set of input places of  $\tau$  and  $\tau^\bullet$  is the set of output places of  $\tau$ .

We represent a Petri net as an oriented bipartite graph  $G = (L \cup T, E)$ . Places are represented by circular vertices and transitions are represented by rectangular vertices. The set of oriented edges  $E$  is the union of the edges  $\{(l, \tau) \in L \times T \mid l \in \bullet\tau\}$  and the edges  $\{(\tau, l) \in T \times L \mid l \in \tau^\bullet\}$ .

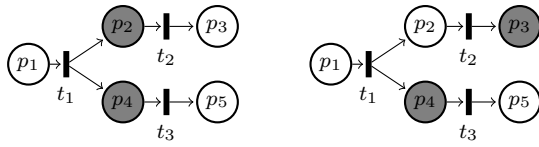

**Figure 5. An example of a simple Petri net**

We depict the state of a Petri net by *marking* some places with *tokens*. We say that a place is *marked* if it contains a token. A transition  $\tau$  can be executed if all its input places  $\bullet\tau$  contain a token. Upon the execution of  $\tau$ , tokens in input places  $\bullet\tau$  are removed and output places in  $\tau^\bullet$  are marked. Formally, let  $\longrightarrow_S$  be the set of triples  $(m, p, m')$  such that  $\exists \tau = (\bullet\tau, p, \tau^\bullet) \in T$ , where  $\bullet\tau \subseteq m$  and  $m' = (m \setminus \bullet\tau) \cup \tau^\bullet$ . The behavior of a Petri net  $S$  can be defined by a labeled transition system  $(2^L, P, \longrightarrow_S)$ .

Figure 5 shows an example of a Petri net in two successive markings. This Petri net has five places  $\{p_1, \dots, p_5\}$  and three transitions  $\{t_1, t_2, t_3\}$ . The places containing a token are depicted with gray background. The right figure shows

the resulting state of the left Petri net when transition  $t_1$  is fired.

Intuitively, the Petri net that defines a scheduler component is constructed as follows. We associate a token with each request. This token circulates through three types of places: *waiting* places, *received* places, and *response* places. A transition from a waiting place to a received place occurs when a request is received. The set of marked received places determines the received requests and, thus, the enabled interactions. Transitions from received places to response places correspond to interactions. The execution of an interaction transition collects the required tokens in received places and puts them in appropriate response places. A transition from a response place to a waiting place sends the corresponding response.

Let  $a = \{p_i\}_{i \in I}$  be an interaction. We say that a set of requests  $\{req_i\}_{i \in I}$  *enables*  $a$  iff  $\forall i \in I, p_i \in req_i$ , that is, if for each port in  $a$ , there is one request of the set that provides this port. For each set of requests that enables  $a$ , we add a transition from the received to response places. Definition 7 formalizes the construction of the scheduler.

**Definition 7.** Let  $B = \gamma(B_1, \dots, B_n)$  be a BIP composite component,  $REQ = \bigcup_{i=1}^n REQ_i$  be the set of all requests and  $RES = \bigcup_{i=1}^n P_i$ , where  $P_i$  is the set of ports of  $B_i$ , be the set of all responses. We define the centralized scheduler  $S$  as a Petri net  $(L, P, T)$  where:

- The set  $L$  of places is the union of the following:
  1. The set  $\{w_{req} \mid req \in REQ\}$  of waiting places.
  2. The set  $\{r_{req} \mid req \in REQ\}$  of received places.
  3. The set  $\{s_{p, req} \mid req \in REQ, p \in req\}$  of response places.
- The set  $P$  of ports is  $RES \cup REQ \cup \gamma$ , which are respectively *send-ports*, *receive-ports* and *unary ports*.
- The set  $T$  of transitions consists of the following:
  1. (*waiting to received*) For each request  $req \in REQ$ ,  $T$  contains the request transition  $(w_{req}, req, r_{req})$ ,
  2. (*received to response*) For each interaction  $a \in \gamma$  and each set of requests  $\{req_j\}_{j \in J}$  that enables  $a$ ,  $T$  contains the transitions  $(\{r_{req_j}\}_{j \in J}, a, \{s_{p_j, req_j}\}_{j \in J})$ , where  $\forall j \in J, \{p_j\} = req_j \cap a$ .
  3. (*response to waiting*) For each request  $req \in REQ$ ,  $T$  contains the set of response transitions  $\{(s_{p, req}, p, w_{req}) \mid p \in req\}$ .

Figure 6 depicts the scheduler constructed for the composite component presented in Figure 3. The dotted places are the waiting places redrawn here for the sake of readability. Initially, all waiting places contain a token. In the depicted state, we assume that both request  $req_0^s$  and  $req_1^s$  have been received. Then, the execution of transition  $p_0p_1$  is possible and brings the tokens associated to  $req_0^s$  and  $req_1^s$  in response places. Then, these tokens return to their initial places by sending the responses  $p_0$  and  $p_1$ .

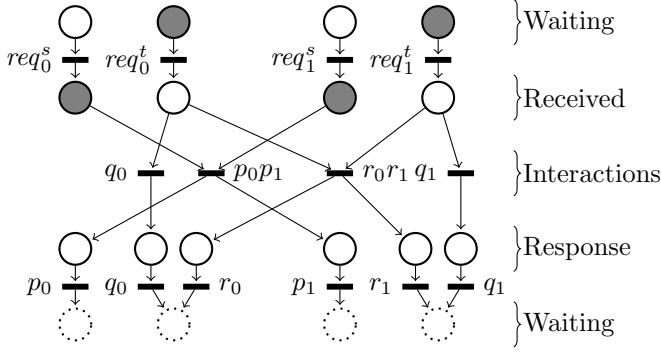

Figure 6. A scheduler component for Figure 3

### 3.3. Interactions between Send/Receive Atomic Components and the Scheduler

The next step of our transformation is to construct the set  $\gamma^{SR}$  of interactions between Send/Receive atomic components and the scheduler. To avoid confusion between ports of the scheduler and atomic components, we prefix the ports that appear in the scheduler by  $S$ : and we leave the ports of atomic components as they are.

**Definition 8.** Let  $B = \gamma(B_1, \dots, B_n)$  be a composite component,  $B_1^{SR}, \dots, B_n^{SR}$  be the corresponding Send/Receive atomic components, and  $S$  be the scheduler constructed for  $B$ . The set of interactions  $\gamma^{SR}$  is the union of the following:

- The set of all request interactions from components to scheduler  $\{(req, S: req) | req \in REQ\}$ ,
- The set of all response interactions from scheduler to components  $\{(S: p, p) | p \in RES\}$ , and
- The set of all unary interactions  $\{S: a\} | a \in \gamma\}$  corresponding to interaction transitions in the scheduler.

Observe that by construction of  $\gamma^{SR}$  the request ports are send-ports in atomic components and receive-ports in the scheduler  $S$ . Likewise, the response ports are send-ports in the scheduler and receive-ports in atomic components. The unary ports of the scheduler (that are labeled by original interactions from  $\gamma$ ) remain unary interactions.

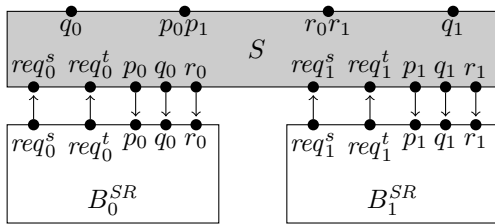

Figure 7. A composite Send/Receive component

Figure 7 shows the Send/Receive composite component by transforming the composite component in Figure 3-b. We use arrows to denote the direction of communications. For the sake of clarity, we have omitted the prefixes for naming the scheduler ports. Non-connected ports of the scheduler are unary interactions, that is interactions not subject to synchronization constraints.

### 3.4. Correctness of the Transformation

In this section, we first show that the composite component  $B^{SR}$  we built thus far is a well-formed Send/Receive component. In particular, we have to verify that for each Send/Receive interaction, a receive-port is enabled when its corresponding send-port becomes enabled. Then, we show that the composite component  $B^{SR}$  is observationally equivalent to the composite component  $B$ .

A state of the composite component  $B$  is given by the  $n$ -tuple  $s = (s_1, s_2, \dots, s_n)$  where  $s_i$  is the state of the component  $B_i$ . A state of the composite component  $B^{SR}$  also takes into account the state of the Scheduler which is described by its marking, denoted  $m$ . Thus, we will denote the state of  $B^{SR}$  by  $s^\perp = (s_1^\perp, s_2^\perp, \dots, s_n^\perp, m)$ . We also denote by  $Q$  the set of all possible states of the composite component  $B$  and by  $Q^{SR}$  the set of all possible states of  $B^{SR}$ .

**Lemma 1.** Let  $B^{SR}$  be the Send/Receive transformation of  $B$ . Then, for each Send/Receive interaction  $(s, r) \in \gamma^{SR}$ , whenever a sender port  $s$  becomes enabled, the associated receiver port  $r$  is already enabled.

*Proof:* Intuitively, this property holds since each component starts listening to any response by the time it sends a request. Dually, the scheduler starts listening again to any request as soon as it sends the corresponding response.

Let  $B_i^{SR}$  be a Send/Receive atomic component. We show that all Send/Receive interactions involving  $B_i^{SR}$  meets the proposition. We abstract the state of  $S$  by considering only the information related to  $B_i$  and  $S$ . We distinguish the following cases, according to the state  $(s_i^\perp, m)$ :

- $s_i^\perp = \perp_{s_0}, m \supseteq \{w_{req^s} | s \in Q_i\}$ , where  $\perp_{s_0}$  is a state of  $B_i^{SR}$ , and  $m$  contains all places  $w_{req^s}$  associated to requests from  $B_i^{SR}$ . The send-port  $req^{s_0}$  is enabled as well as the receive-port  $S: req^{s_0}$ . Thus, the property holds for the initial configuration, and in general for configurations of this form. Moreover, by executing this request interaction, we fall into the second situation.
- $s_i^\perp = s_0, m \supseteq \{r_{req^{s_0}}\} \cup \{w_{req^s} | s \in Q_i, s \neq s_0\}$ . From this configuration, no send-port is enabled.
- $s_i^\perp = s_0, m \supseteq \{s_{p.req^s}\} \cup \{w_{req^s} | s \in Q_i, s \neq s_0\}$ . Such a configuration is reached whenever the scheduler executes an interaction involving  $B_i^{SR}$ . The send-port  $p$  is enabled in  $S$  as well as the receive-port  $p$  in  $B_i^{SR}$  so the response interaction is enabled. Moreover, by executing this response interaction, this case is reduced to the first case.

■

Now, we show that if we observe only the unary interactions in  $B^{SR}$ , that correspond to the original interactions in  $B$ , these two composite components  $B$  and  $B^{SR}$  are observationally equivalent. Let us fix some notations. Let  $s^\perp, t^\perp \in Q^{SR}$  be two states of  $B^{SR}$  and  $a \in \gamma^{SR}$  be an interaction such that  $s^\perp \xrightarrow{a}_{SR} t^\perp$ . We rewrite  $s^\perp \xrightarrow{\beta}_{SR} t^\perp$  if  $a$  is a Send/Receive interaction, otherwise  $a$  is a unary interaction and is observable in  $B^{SR}$ . It can be shown that the relation  $\xrightarrow{\beta}_{SR}$  is terminating and confluent. Formally, for any state  $s^\perp$  there is a unique state  $[s^\perp]$  that can be reached by executing all the possible Send/Receive interactions, after a finite number of steps, that is,  $s^\perp \xrightarrow{\beta^*}_{SR} [s^\perp]$  and  $[s^\perp] \not\xrightarrow{\beta}_{SR}$ .

**Proposition 1.** *Let  $B$  be a composite component and  $B^{SR}$  be its Send/Receive version.  $B$  and  $B^{SR}$  are observationally equivalent when hiding all Send/Receive interactions in  $B^{SR}$ .*

*Proof :* We define the relation  $R = \{(s, s^\perp) \in Q \times Q^{SR} | \forall 1 \leq i \leq n [s^\perp]_i = s_i\}$ . It can be shown that  $R$  is an observational equivalence as follows. Let  $s, t \in Q$  be some states of  $B$ ,  $s^\perp, t^\perp \in Q^{SR}$  be some states of  $B^{SR}$ , and  $a \in \gamma$  an interaction. It follows that:

- i) If  $(s, s^\perp) \in R$  and  $s^\perp \xrightarrow{\beta}_{SR} t^\perp$ , then  $(s, t^\perp) \in R$ .
- ii) If  $(s, s^\perp) \in R$  and  $s^\perp \xrightarrow{a}_{SR} t^\perp$ , then  $\exists t \in Q$  such that  $s \xrightarrow{a} t$  and  $(t, t^\perp) \in R$ .
- iii) If  $(s, s^\perp) \in R$  and  $s \xrightarrow{a} t$  then  $\exists t^\perp \in Q^{SR}$ , such that  $s^\perp \xrightarrow{\beta^* a}_{SR} t^\perp$  and  $(t, t^\perp) \in R$ .

All these conditions can be checked depending on the structure of the state in a similar way to [4]. ■

### 3.5. Decentralized Scheduler

The idea behind decentralization is to decompose the centralized scheduler component into a set of “disjoint” scheduler components. Let  $S = (L, P, T)$  be a centralized scheduler. A decomposition of  $S = \bigcup_{j=1}^m S_j$ , is a set of 1-safe Petri nets  $S_i = (L_i, P_i, T_i)$  such that  $L = \bigcup_{j=1}^m L_j$ ,  $P = \bigcup_{j=1}^m P_j$  and  $T = \bigcup_{j=1}^m T_j$ . We say that a decomposition is disjoint if both  $L = \bigcup_{j=1}^m L_j$  and  $T = \bigcup_{j=1}^m T_j$  are disjoint unions.

Reconsider the Petri net depicted in Figure 6. As shown in Figure 8, it can be decomposed into two disjoint Petri nets, the gray one and the black one. Thus, we build one scheduler for each of these Petri nets.

Since the overall structure of the system changes, we need to redefine the Send/Receive interactions. Let first consider the situation of request ports  $req \in REQ$ . Since there is only one  $req$  labeled transition in the centralized scheduler  $S$ , there is only one decentralized scheduler  $S_i$  that contains this transition and the associated port  $req$ . We denote this port by  $S_{j_{req}} : req$ . The situation of response ports  $p \in RES$  is different. The same response port  $p \in RES$  can label multiple

transitions in  $S$ , thus there might be more than one scheduler  $S_j$  that triggers the port  $p$ . If the response port  $p$  is contained in the decentralized scheduler  $S_j$ , we denote it  $S_j : p$ . The formal definition is provided below.

**Definition 9.** *Let  $\gamma^{SR}(B_1^{SR}, \dots, B_n^{SR}, S)$  be a Send/Receive composite component and  $S_1, \dots, S_m$  be a decomposition of  $S$ . The set of interactions  $\gamma_2^{SR}$  is the union of the following :*

- *The set of all requests from components to schedulers  $\{(req, S_{j_{req}} : req) | req \in REQ\}$*
- *The set of all responses from schedulers to components  $\{(S_j : p, p) | p \in P_j\}$*
- *The set of all unary interactions  $\{S : a | a \in \gamma\}$*

Then we define the decentralized Send/Receive version of  $B$ , denoted  $B_2^{SR} = \gamma_2^{SR}(B_1^{SR}, \dots, B_n^{SR}, S_1, \dots, S_m)$ . Figure 9 presents the decentralized version of the composite component originally presented in Figure 3. The gray Petri net from Figure 8 is  $S_1$  and the black one is  $S_2$ .

**Theorem 1.**  *$B_2^{SR}$  is observationally equivalent to  $B^{SR}$ .*

*Proof :* The centralized scheduler  $S$  in  $B^{SR}$  is the juxtaposition of the decentralized schedulers  $S_1, \dots, S_m$ . Thus, we can say that a state of  $B^{SR}$  and a state of  $B_2^{SR}$  are equivalent if the marked places are the same. This relation is an observational equivalence since the marked places enable the same interactions in both models. ■

## 4. Transformation from Send/Receive BIP into C++

In this section, we describe how we generate for a scheduler and a Send/Receive BIP atomic component pseudo C++ code. Notice that since the behavior of these components are formalized as Petri nets, we only present generation of C++ code for a Petri net whose transitions are labeled by send-ports, receive-ports, or internal actions (see C++ Pseudo Code 1).

Initially, each component creates a TCP socket and establishes reliable connections with all components that it needs

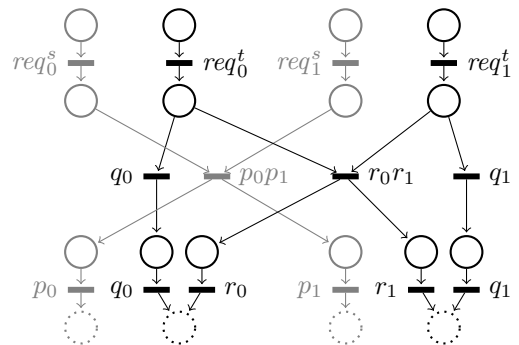
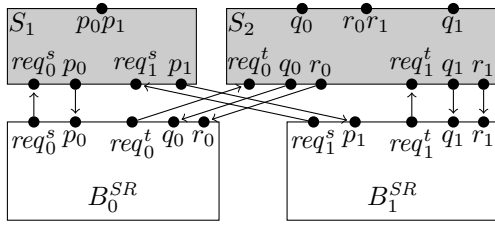

Figure 8. Splitting the scheduler





**Figure 9. A Send/Receive composite component with Decentralized Scheduler**

to interact (Lines 1-2). These interactions and their corresponding physical connections are determined according to the complete Send/Receive BIP model and a *configuration file*. This file specifies the IP address and port number of all components for final deployment. We assign one Boolean variable to each place of the given Petri net, which shows whether or not the place contains the token. Thus, the initial state of the Petri net is determined by an initial assignment of these variables (Line 3).

After initializations, the code enters an infinite loop that executes the transitions of the Petri net as follows. For each step, the code scans the list of all possible transitions and gives priority to transitions that are labeled by a send-port (Lines 6-10) or unary ports of the given Petri net (Lines 11-15). Actual emission of data is performed by an invocation of the TCP sockets system call `send()` in Line 7. Once data transmission or an internal computation is completed, tokens are removed from input places and put to output places of the corresponding transitions (Lines 8 and 13).

Finally, if no send-port is enabled and all internal computations are completed, execution stops and waits for messages from other components (Line 17). Once one of the sockets contains a new message, the component resumes its execution and receives the message (Line 18). Note that based on the structure of Send/Receive components and schedulers developed in Section 3, it is straightforward to observe that our code avoids creating deadlocks by giving priority to send-ports and internal computations.

## 5. Experimental Results

We have implemented and integrated the transformations described in Sections 3 and 4 in the BIP toolset. The tool takes a composite BIP model in the global state semantics and a network configuration file as input and generates the corresponding C++ executable for each atomic component and scheduler. Each executable can be run independently on a different machine or a processor core.

We now present the results of our experiments for two sorting algorithms often used as parallel computing benchmarks. The structure and behavior of the two benchmarks are considerably different in terms of conflicting interactions, number of schedulers, and the required computation and communication times. All experiments in this section are run on (single or dual-core) 2.2 GHz Intel machines running under Debian

---

### C++ Pseudo Code 1 Petri net

---

**Input:** A Petri net of a Send/Receive BIP component and a configuration file.

**Output:** C++ code that implements the given Send/Receive Petri net

```

// Initializations
1: CreateTCPSocket();
2: EstablishConnections();
3: PrepareInitialState();

4: while true do
5:   // Handling send-ports and internal computations
6:   if there exists an enabled transition labeled by a send-port
       then
7:     send(...);
8:     PrepareNextState();
9:     continue;
10:  end if
11:  if there exists an enabled internal transition then
12:    DoInternalComputation();
13:    PrepareNextState();
14:    continue;
15:  end if

16:  // Handling receiving messages
17:  select(...);
18:  rcv(...);
19:  PrepareNextState();
20: end while

```

---

Linux connected through a dedicated 100 Mb/s Ethernet network. We consider five different configurations:  $1c$ ,  $2c$ ,  $2c'$ ,  $4c$  and  $4c'$ , which denote respectively, one single-core machine, one dual-core machine, two single-core machines, two dual-core machines, and four single-core machines.

Moreover, for each experiment we compare the performance of the BIP generated code against a handwritten MPI program, implementing the same sorting algorithm and deployed on the same configuration.

### 5.1. Network Sorting Algorithm [1]

We consider  $2^n$  atomic components, each of them containing an array of  $N$  items. The goal is to sort all the items, so that the items in the first component are smaller than those of the second component and so on. Figure 10-a shows the high-level model of the Network Sorting Algorithm for  $n = 2$  using incremental and hierarchical composition of components<sup>1</sup>. The atomic components  $B_1 \dots B_4$  are identical. Each atomic component computes independently the minimum and the maximum values of its array. Once this computation completes, interaction  $\gamma_1$  compares the maximum value of  $B_1$

<sup>1</sup>We note that a composite component obtained by composition of a set of atomic components (as described in Section 2) can be composed with other components in a hierarchical and incremental fashion using the same operational semantics. It is also possible to flatten a composite component and obtain a non-hierarchical one [7].

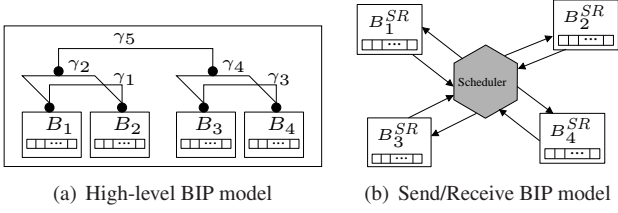

Figure 10. Network Sorting Algorithm.

with the minimum value of  $B_2$  and swaps them if the maximum of  $B_1$  is greater than the minimum of  $B_2$ . Otherwise, the corresponding arrays are correctly sorted and interaction  $\gamma_2$  gets enabled. This interaction exports the minimum of  $B_1$  and the maximum of  $B_2$  to interaction  $\gamma_5$ . The same principle is applied in components  $B_3$  and  $B_4$  and interactions  $\gamma_3$  and  $\gamma_4$ . Finally, interaction  $\gamma_5$  works in the same way as interaction  $\gamma_1$  and swaps the minimum and the maximum values, if they are not correctly sorted. Notice that all interactions in Figure 10-a are in conflict and, hence, our transformation constructs a single scheduler that encompasses all these interactions (see Figure 10-b), and which cannot be decomposed. Moreover, let us remark that the handwritten MPI program has an identical structure, that is several components and one scheduler to deal with communications. We run two sets of experiments for  $n = 1$  (2 atomic components) and  $n = 2$  (4 atomic components).

**Case  $n = 1$ .** We consider three different configurations:  $1c$ ,  $2c$  and  $2c'$ . For  $1c$ , we use a one single-core machine, which runs the two atomic components and the scheduler. For  $2c$ , we use one dual-core machine, where each core runs an atomic component and one of the cores runs also the scheduler. The component distribution is similar for  $2c'$ , except that the cores now are in different machines.

The results are reported in Table 1 for arrays of size  $k \times 10^4$  elements, for  $k = 20, 40, 80, 160$ . In general, the generated BIP code outperforms the equivalent MPI program. For instance, the execution time for sorting an array of size  $80 \times 10^4$ , for the configuration  $2c$  is: 669 seconds for MPI, and 600 seconds for BIP. Moreover, the difference is more important for an array of size  $160 \times 10^4$ , for the configuration  $2c'$ : 3090 seconds for MPI and only 2601 seconds for BIP. As expected, in the configuration  $2c'$ , we gain less speedup compared to  $2c$ , both for MPI and BIP, because of the network communication overhead (for this example the number of messages sent by each component is equal to the size of the array  $\times 2$ ). Furthermore, for the configuration  $1c$ , we notice an important overhead due to context switching between processes which appears to be more significant in the case of MPI.

**Case  $n = 2$ .** Again, we consider three configurations:  $1c$ ,  $4c$ ,  $4c'$ . For  $1c$ , we use one single-core machine, where the four atomic components run along with the scheduler. For  $4c$ , we use two dual-core machines and place each atomic component on a different core. The scheduler is placed arbitrarily on one of the cores. For  $4c'$ , the distribution of components and scheduler is similar to  $4c$ .

The results are reported in Table 1 for arrays of size  $k \times$

$k$	MPI			BIP		
	$1c$	$2c$	$2c'$	$1c$	$2c$	$2c'$
20	118	40	60	105	34	100
40	497	157	198	409	133	256
80	1936	669	764	1526	600	758
160	8259	2833	3090	5819	2343	2601

Table 1. Performance of network sorting algorithm ( $n = 1$ ).

$k$	MPI			BIP		
	$1c$	$4c$	$4c'$	$1c$	$4c$	$4c'$
20	224	70	107	217	168	217
40	808	176	240	795	392	502
80	3239	655	789	3071	1792	1264
160	12448	2775	3217	11358	4621	3726

Table 2. Performance of network sorting algorithm ( $n = 2$ ).

$10^4$  elements, for  $k = 20, 40, 80, 160$ . We remark that the MPI program outperforms the corresponding BIP program. As can be seen in Table 2 the execution time for sorting an array of size  $160 \times 10^4$ , for the configuration  $4c$  is: 2775 seconds for handwritten MPI, and 4621 seconds for BIP. This overhead is essentially due to communication. The number of messages exchanged is now four times bigger than for the case  $n = 1$  and MPI provides a more efficient implementation for communication.

## 5.2. Bitonic Sorting [6]

Bitonic sorting is one of the fastest sorting algorithm suitable for distributed implementation in hardware or in parallel processor arrays. A sequence is called bitonic if it is initially strictly increasing then it is strictly decreasing. The first step of the algorithm consists in constructing a bitonic sequence. Then, by applying a logarithmic number of bitonic merges, the bitonic sequence is transformed into totally ordered sequence. We provide an implementation of the bitonic sorting algorithm in BIP using four atomic components, each one handling one part of the array. These components are connected as shown in the Figure 11. The six connectors are non conflicting. Hence, we use six schedulers for the distributed implementation. In this example each component sends only three messages, each one containing its own array. We run experiments for three configurations:  $1c$ ,  $4c$ ,  $4c'$ . For  $1c$ , we use one single-core machine, where the four atomic components along with the schedulers run. For  $4c$ , we use two dual-core machines and place each atomic component on a different core. We also distribute the schedulers over the four cores, such as to reduce the network communication overhead. For

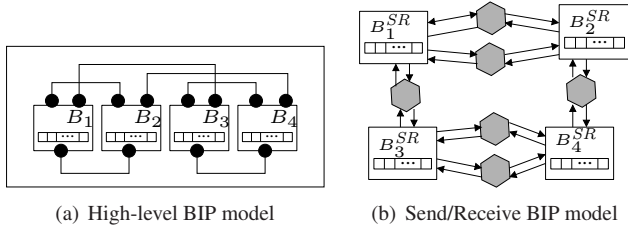

Figure 11. Bitonic Sorting Algorithm.

$4c'$ , we use the same distribution for components and schedulers. The results are reported in Table 1 for arrays of size  $k \times 10^4$  elements, and  $k = 20, 40, 80, 160$ . As can be seen in Table 3 the overall performance of MPI and BIP implementations are quite similar. For example, the execution time for sorting an array of size  $80 \times 10^4$ , for the configuration  $4c$  is: 240 seconds for MPI, and 390 seconds for BIP. The overhead of BIP is due to extra communication between atomic components and the schedulers. This overhead is not present in MPI where schedulers are not explicitly implemented and messages are sent and received directly between components.

$k$	MPI			BIP		
	$1c$	$4c$	$4c'$	$1c$	$4c$	$4c'$
20	80	14	14	96	23	24
40	327	59	60	375	96	100
80	1368	240	240	1504	390	397
160	5605	1007	958	6024	1539	1583

Table 3. Performance of bitonic sorting algorithm.

## 6. Conclusion

In this paper, we proposed a method for transforming high-level models in BIP [5] into distributed implementations. The BIP (Behavior, Interaction, Priority) language is based on a semantic model encompassing composition of heterogeneous components. Our transformation consists of three steps: (1) we transform the given BIP model into another BIP model that operates in partial state semantics and expresses multiparty interactions in terms of asynchronous message passing using send/receive primitives, (2) we construct a set of Schedulers each executing a subset of conflicting interactions, and (3) we transform the intermediate BIP model into actual C++ distributed code that employs TCP sockets for communication.

We presented a set of experiments that validates the effectiveness of our approach in achieving parallelism regardless of the platform and architecture. Our experiments illustrated that depending upon the structure of the model, the distributed code generated using our method exhibits close to ideal level of parallelism and communication overhead. We also showed

that in some cases, the performance of the generated code is competitive with the performance of hand-written code developed using the Message Passing Interface (MPI).

For future work, we plan to pursue several directions. One direction is introducing the notion of time in distributed semantics of BIP. Providing timing guarantees in a distributed setting has always been a challenge and BIP is not an exception. Another avenue to explore is to build a library of transformations based on different solutions to the conflict resolution problem. As mentioned in the introduction, one can reduce our problem to distributed graph matching, distributed independent set, and distributed clique. These approaches would construct a wide range of designs for the distributed Scheduler, each appropriate for a particular application domain and platform. Thus, another future task is to identify a mapping from each transformation to an application domain and platform. Yet another research direction is to generate other types of code and communication mechanisms. For instance, one can exploit the communication and synchronization mechanisms provided in the Message Passing Interface (MPI). Of course, a central issue that needs to be rigorously studied for each type of transformation and target language or platform is performance analysis and communication overhead.

## References

- [1] M. Ajtai, J. Komlós, and E. Szemerédi. Sorting in  $c \log n$  parallel steps. *Combinatorica*, 3(1):1–19, 1983.
- [2] R. Bagrodia. A distributed algorithm to implement n-party rendezvous. In *Foundations of Software Technology and Theoretical Computer Science, Seventh Conference (FSTTCS)*, pages 138–152, 1987.
- [3] R. Bagrodia. Process synchronization: Design and performance evaluation of distributed algorithms. *IEEE Transactions on Software Engineering (TSE)*, 15(9):1053–1065, 1989.
- [4] A. Basu, P. Bidinger, M. Bozga, and J. Sifakis. Distributed semantics and implementation for systems with interaction and priority. In *Formal Techniques for Networked and Distributed Systems (FORTE)*, pages 116–133, 2008.
- [5] A. Basu, M. Bozga, and J. Sifakis. Modeling heterogeneous real-time components in BIP. In *Software Engineering and Formal Methods (SEFM)*, pages 3–12, 2006.
- [6] K. E. Batcher. Sorting networks and their applications. In *AFIPS '68 (Spring): Proceedings of the April 30–May 2, 1968, spring joint computer conference*, pages 307–314, New York, NY, USA, 1968. ACM.
- [7] M. Bozga, M. Jaber, and J. Sifakis. Source-to-source architecture transformation for performance optimization in BIP. In *Symposium on Industrial Embedded Systems (SIES)*, pages 152–160, 2009.
- [8] K. M. Chandy and J. Misra. The drinking philosophers problem. *ACM Transactions on Programming Languages and Systems (TOPLAS)*, 6(4):632–646, 1984.
- [9] K. M. Chandy and J. Misra. *Parallel program design: a foundation*. Addison-Wesley Longman Publishing Co., Inc., Boston, MA, USA, 1988.
- [10] Ewing and R. Thakur. *Using MPI-2: Advanced Features of the Message Passing Interface*. MIT Press, 1999.
- [11] J. A. Pérez, R. Corchuelo, and M. Toro. An order-based algorithm for implementing multiparty synchronization. *Concurrency and Computation: Practice and Experience*, 16(12):1173–1206, 2004.