



HAL
open science

Class E dual band PA performances with PAPR repartition in the context of nomadic multi-radio architecture

Antoine Diet, Ajib Bahi, Martine Villegas, Geneviève Baudoin

► **To cite this version:**

Antoine Diet, Ajib Bahi, Martine Villegas, Geneviève Baudoin. Class E dual band PA performances with PAPR repartition in the context of nomadic multi-radio architecture. Asia Pacific Microwave Conference, APMC 2010, December 7-10, Yokohama, Japon., Dec 2010, Yokohama, Japan. pp.W3EG-19. hal-00553314

HAL Id: hal-00553314

<https://hal.science/hal-00553314>

Submitted on 7 Jan 2011

HAL is a multi-disciplinary open access archive for the deposit and dissemination of scientific research documents, whether they are published or not. The documents may come from teaching and research institutions in France or abroad, or from public or private research centers.

L'archive ouverte pluridisciplinaire **HAL**, est destinée au dépôt et à la diffusion de documents scientifiques de niveau recherche, publiés ou non, émanant des établissements d'enseignement et de recherche français ou étrangers, des laboratoires publics ou privés.

Class E dual band PA performances with PAPR repartition in the context of nomadic multi-radio architecture

Antoine Diet^{#1}, Ajib Bahi^{*2}, Martine Villegas^{*2}, Geneviève Baudoin^{*2}

[#]LSS-DRE UMR 8506 (CNRS, Supelec, Université Paris Sud-11). Supélec, Plateau du Moulon F-91192 Gif Sur Yvette
¹antoine.diet@lss.supelec.fr

^{*}Université Paris-Est, ESYCOM-ESIEE Paris, EA 2552. Groupe ESIEE, cite Descartes, Noisy-Le-Grand, 93162, France
²{m.villegas, g.baudoin, a.bahi}@esiee.fr

Abstract — In this paper, we focus on the performances optimization of a power stages for a nomadic transmitter front-end for multi-radio applications. Performance of such a front-end are to guarantee efficiency (peak and average) whatever the modulation scheme, carrier frequency and bandwidth are. Herein, we delimited the case of study to two band of interest: LTE (2-2.2 GHz) and WiMAX (3.6-3.8 GHz), and designed a dual-band PA. The PA operates in class E, in order to preserve the efficiency. The idea is to demonstrate the ability to amplify amplitude modulated signal and/or control the mean power of the signal by supply and driving signal variations, at the both frequency bands expected. Results show the possibility to efficiently amplify modulated signal or to adapt to mean power variations on the two bands. These new results allow to reconsider the transmitter architectures design approaches.

Index Terms — RF architectures, multi-radio, class E PA.

I. NOMADIC MULTI-RADIO FRONT END

Due to the user increasing demand in high data rate and mobility, some concept such as cognitive radio are attractive and promising in wireless communications. Nowadays, the context of cognitive radio includes nomadic communications and the adaptability to any specifications of cellular and connectivity standards such as UMTS, LTE, WiMAX, WiFi and so on. This flexibility of “the RF part” in a transceiver is known under the concept of “multi-radio”, and drives it to consider the design of a transmitter that must:

- Adapt to any of the modulation schemes (power or spectral efficient modulation). Orthogonal Frequency Division Multiplex (OFDM) is a good representative of high data rate wideband signals used (ex. WiMAX and WiFi).

- Provide different bandwidths and carrier frequencies, in the idea of opportunism spectrum allocation (1 to 100 MHz).

- Present a low average efficiency, due to the interest in battery lifetime. This is mandatory for the transmitter part where the Power Amplifier (PA) is responsible for a major part of the current consumption.

- Guarantee the linearity of the transmitter whatever the modulation, bandwidth, mean power and carrier frequency are. This includes power scale-ability, because the transmitter is not supposed to operate at its maximum power all the time. In fact, it is often necessary to operate at a lower level.

- Do not produce crippling spectral re-growths that could disturb other transceivers (co-existence). This implies a severe filtering selectivity at the different “carrier frequency and bandwidth” possibilities.

Herein, we focus on the design of the transmitter front-end for the above-mentioned goals of the multi-radio. The challenge of such a transmitter is to provide the enumerated requirements while realizing frequency transposition, power amplification and filtering before feeding the antenna. The front-end must adapt to any characteristic of the signal, for example the amplitude variation. This variation can be slow for average power control or fast, for dynamic amplitude information (also called dynamic envelope information). The PAPR (Peak to Average Power Ratio) characterizes the importance of the signal dynamic for a given modulated signal. For example, the PAPR in the case of OFDM signal can reach more than 10 dB, depending on the number of sub-carriers [16].

High PAPR causes crippling non-linearities at the PA stage. This is a difficulty that implies linearization techniques (feedback, feed-forward, pre-distortion) or linear architecture (Envelope Elimination and Restoration EER, Envelope Tracking/Following ET, LINC, CALLUM...) [1]. Polar based linear architectures, such as EER and ET, have known a great success these years with the challenging possibilities of reducing the PAPR by envelope coding (PWM, $\Sigma\Delta$) [11][13]. In such architecture, the use of a switched high efficiency PA is interesting for an efficiency maximization of the amplification, and the coded envelope can provide the necessary constant power signal for driving such PAs [11][13][14][16][17]. The efficiency of such architecture is favored by the choice of a switched PA in class E, whose theory has been studied in [2][3][4][5][6][7][8][9][10].

These solutions show a new technical lock that is filtering requirement. Due to the important spectral re-growths generated by the envelope coding (still remaining after the amplification), the overall efficiency is impacted by its coding efficiency and need a mandatory filtering, to respect standards requirements [16]. This results in a linear but not so efficient solution. The multi-radio front-end must be designed with the idea of a reconfigurable and/or multiple pass-band profile (multi-band) while power amplification is performed [12][15][18]. Our idea is to demonstrate the feasibility of managing high PAPR signal for suitable multi-radio front-end: high average efficiency, linearity and multi-band possibility. We present in the part II of this paper the design of a dual-band PA in class E, following a sub-optimal design method, whose principle was presented in [18]. The

technology at these frequencies is integrated because we choose a transistor in the idea to adapt to LTE (2-2.2 GHz) and WiMAX (3.6 – 3.8 GHz). Signals of such standards are typically OFDM, and that is why the power scale-ability is studied in part III (slow and fast variation) by supply or driving signal amplitude variation.

The novelty of this paper is to demonstrate the efficient amplification of amplitude information (modulated signal) with a switched mode PA (class E), at two frequency bands of interest. The methodology used can be extended for multiple bands of operation and the importance of PAPR repartition (supply and driving signal) is underlined as a new way of optimization in polar based architectures.

II. DUAL-BAND CLASS E PA: NEW METHOD AND DESIGN

The design of the dual-band PA is based on the methodology exposed in [18], as figure 1 resumes the different steps: by defining the power capability of the transistor and extracting the major part of its output non-linearities, a sub-optimum design in frequency is possible, if the output network has sufficient degrees of freedom (number of L and C). The efficiency is computed in transient simulation by extracting the real power dissipated by the transistor and delivered to the load. Herein, the load is simulated with wideband antenna measurements (Vivaldi type designed for 1.8 to 6 GHz) as in [18].

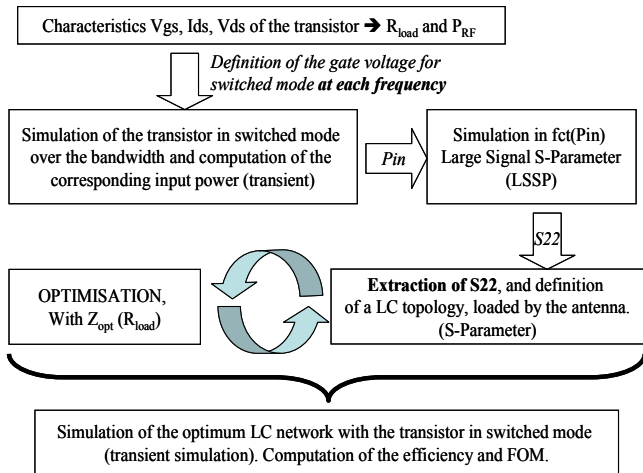

Fig. 1 : Methodology for class E multi-band design [18]

This method takes into account the transistor switching limit, and its output non-linear behavior, rather than idealizing it. As the hard switching is difficult in practice, we worked with integrated transistor model, here the AVAGO ATF 50189. This component can be scaled for 0.3W in switched mode, due to the class E factor of use which is 10.1816 (peak drain current/voltage, 3.56*2.86 [2][4]). Taking into account the maximum drain-to-source voltage of almost 10V, we supplied the drain with $V_{DC} = 3V$. This yields to a DC current of $I_{DC} = 0.1 A$, and a “supply resistance” $R_{DC} = 30 Ohms$. The optimum resistance for the load is $R_{load} = 16.8 Ohms$ [5]. We scaled the loading network input impedance with this value of R_{load} . Once these parameters fixed, we performed a transient

simulation where the transistor is hardly switched and identified the driving power in function of the frequency, $P_{in}(f)$. With $P_{in}(f)$, we simulated a Large Signal S-Parameters (LSSP) simulation in order to extract the major contribution of transistor output non-linearity: S_{22NL} , as the principle is drawn in figure 3. Figure 2 represents the following step of “network optimization”, with the integration of the antenna load measurements and S_{22NL} . The optimization goal is to present the optimal load impedance at the LTE and WiMAX bands while rejecting other spectral components for linearity improvements (high impedance, helping in filtering the signal [5][9][18]). The criterion used is the matching coefficient, modified for the optimal class E load value rather than 50 Ohms, see (1). Optimization results are draw in figure 2, where G_{ADAPT} shows two bands of class E mode of operation.

$$G_{ADAPT} = \Gamma_{with R_{load}}^{class E} (Z) = \frac{Z - 0.826 R_{load} e^{-j 34^\circ}}{Z + 0.826 R_{load} e^{j 34^\circ}} \quad (1)$$

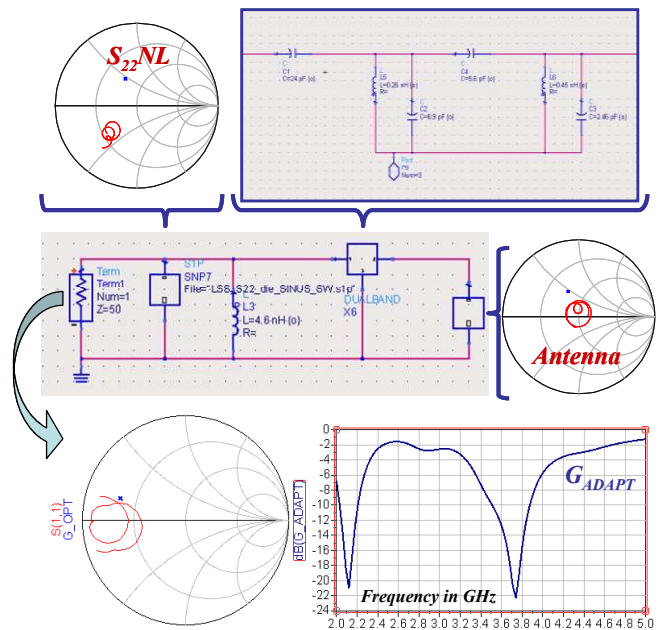

Fig. 2 : Optimization of loading network, with extraction of transistor S_{22NL} , polarization inductance and antenna load. Resulting G_{ADAPT} .

The optimized network is reintroduced in a transient simulation where the transistor is hardly switched at different frequencies, in order to evaluate the class of operation and performance. Figure 3 summarizes the topology used for the PA, and results reported for drain voltage and drain current showed typically switched mode load line behavior. Imperfections in the switching trajectory are due to the intrinsic S_{22NL} of the transistor: mainly non-linear C_{DS} and R_{DS} . At the two wanted frequency bands, the class E “drain waveforms” are observed and the efficiency is reported on figure 4.

Transient simulations are processed with sinusoidal and square signal. Results are reported on figure 4 where real powers (mean of voltage*current) dissipated in the transistor and delivered to the antenna are computed in the two cases.

Also the input power is computed for evaluating the PAE (Power Added Efficiency).

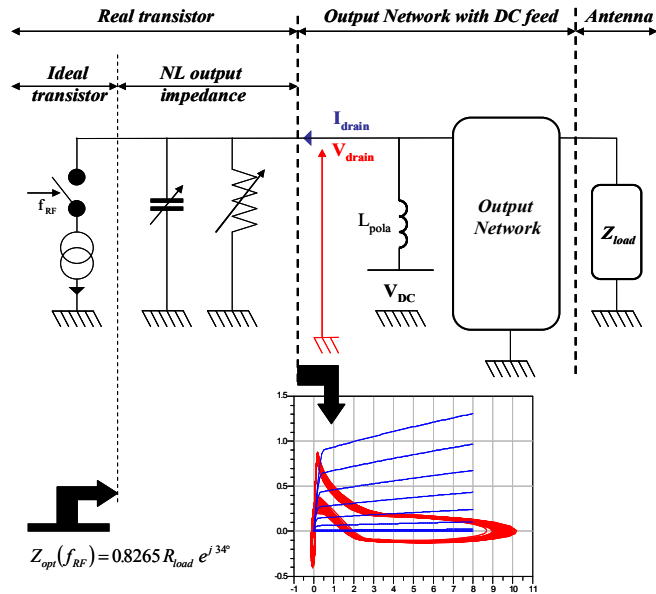

Fig. 3 : Topology of the dual-band PA and simulated dynamic load line

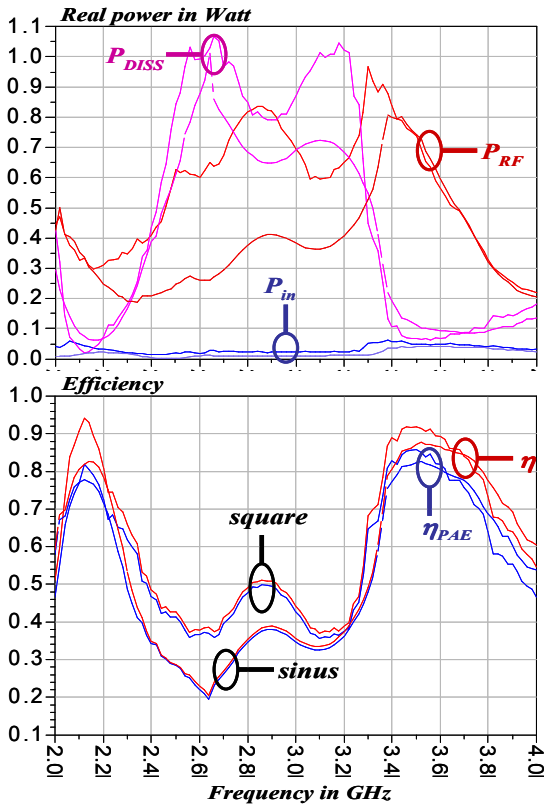

Fig. 4 : Real power for sinus and square driving signal (top) and drain/PAE efficiency (bottom).

Figure 4 demonstrates that high efficiency (80 to 90%) can be reached in the two wanted bands of operation, and that the 0.3W targeted power is attained. The PAE is interestingly high at the same frequencies. This part has shown that it is

possible to design a “dual-band profile” class E PA. Next part will focus on the amplitude modulation possibilities.

III. PAPR REPARTITION

The PAPR causes crippling non-linearity (PA) without a linearization process. This is the challenging lock in the design of front-end for multi-radio because we want a high average efficiency and linearity at the same time. To explore the amplitude modulation possibilities of our dual band PA, we swept the supply drain voltage (V_{ds}) and the high level of the switching driving signal (command signal on V_{gs}). Results are reported in figure 5.

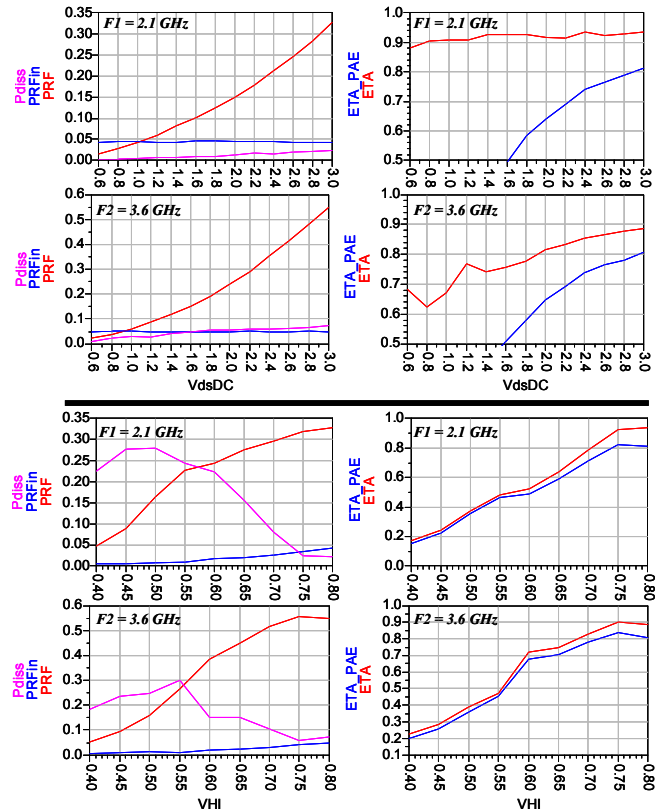

Fig. 5 : At F1 and F2, variation of V_{ds} (4 top figures) and V_{gs} (4 bottom figures). Real power (in, RF, dissipated) and efficiency results.

Figure 5 showed an important dependency of the output power with V_{ds} and V_{gs} (VHI is the maximum value of V_{gs}). The efficiency is less sensitive with V_{ds} variation, as the transistor is highly saturated. VHI reduction drives it to an important decrease in efficiency and we can identify a limit of the transistor switching behavior around $V_{HI} = 0.6$ V. In the idea of PAPR repartition, the amplitude modulation can be done on both voltages, but V_{gs} will affect more the efficiency performance than V_{ds} . These simulations were DC variations, and we introduced, in a second step, sinusoidal modulation on both V_{ds} and V_{gs} signals. These variations are about 100 MHz for V_{gs} and 60 MHz for V_{ds} , representing a potential signal bandwidth. Figure 6 shows the variations at the two frequencies (LTE/WiMAX) and its resulting amplitude information delivered to the load (top). Also the spectrum of

figure 6 shows that the only spectral re-growth to deal with is the second harmonic.

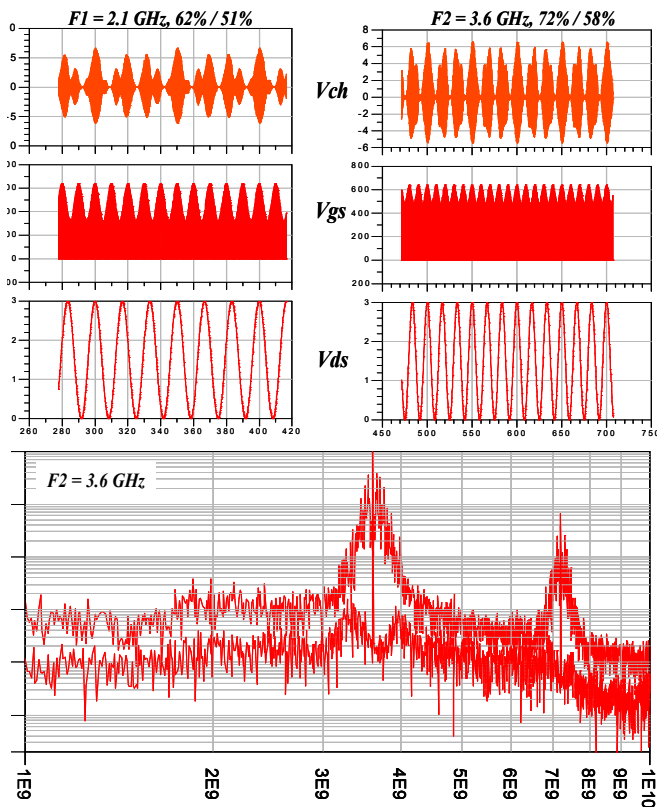

Fig. 6 : Dynamic modulation of Vgs (100 MHz) and Vds (60 MHz) for F1 and F2. Spectrum at F2 (bottom) with and without modulation

Efficiencies (drain and PAE) are computed for modulated signals with the same parameters, at different carrier frequencies. Figure 7 shows performance of 60 to 70% drain efficiency, attained by the dual-band PA for amplitude modulated signal.

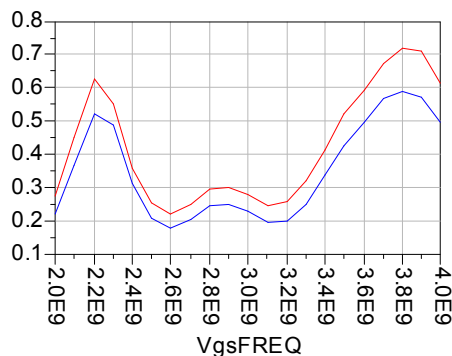

Fig. 7 : Drain and PAE average efficiencies for modulated signals

The ability to restore an amplitude modulation by supply modulation and/or driving signal modulation has been explored for our high efficient dual band class E PA. Efficiencies computed are promising for the use of such structures in multi-radio front-ends (50 % PAE).

IV. CONCLUSION AND PERSPECTIVES

A dual-band class E PA for multi-radio applications has been studied and showed its ability to amplify efficiently modulated signal at two frequency bands of interest, with the same device. The design methodology enables this type of PA to be used in multi-radio architectures, characterised by important PAPR, while considering good performances in output power, efficiency, and power control.

These new results allow to reconsider the transmitter architectures design approaches and give a possibility to solve the tricky problem of power emission in multi-standards or multi-radio.

REFERENCES

- [1] L. Kahn. "Single Sideband Transmission by Envelope Elimination and Restoration". *Proc. of the I.R.E.*, 1952, pp. 803-806.
- [2] N. Sokal, A. Sokal. "Class E, A new Class of high efficiency Tuned switching PAs" *IEEE JSSC*, V10, N3, June 1975, pp 168-176.
- [3] S. Cripps "Advanced techniques in RF Pas design" *Norwood, MA, Artech house*, 2002.
- [4] F. Raab et al. "RF and Microwave PA and Transmitter Technologies" *HF Electronics*, May-November 2003, pp 22-49.
- [5] F. Raab "Idealised operation of the class E tuned PA" *IEEE trans. on Circuits and Systems*, vol. 24, December 1977, pp 725-735.
- [6] A. Grebennikov "Class E high efficiency PA: Historical aspects and prospects" *Applied Microwave and Wireless*, 2002, pp 64-71.
- [7] M. Kazimierczuk "Class E tuned PA with shunt inductor" *IEEE journal of Solid State Circuits*, vol 16, February 1981, pp 2-7.
- [8] T. Mader et al. "Switched mode high efficiency microwave PAs in a free space power combiner array" *IEEE trans. on MTT*, Vol 46, October 2008, pp 1391-1398.
- [9] T. Mury, V. Fusco. "Series-L/Parallel-Tuned Class-E Power Amplifier Analysis" *Proceedings of 35th European Microwave Conference*, October 2005.
- [10] A. Grebennikov, NO Sokal "Switch-mode RF PAs" *Burlington MA, Elsevier*, 2007.
- [11] J. Choi et al. "A $\Sigma\Delta$ digitized polar RF transmitter". *IEEE Trans. on MTT*, Vol. 52, n°12, 2007, pp 2679-2690.
- [12] P. Colantino "Multi-band PA architectural solutions" *Proceedings of European Microwave Week 2009, Whorshop, Rome*, 2009.
- [13] M. Nielsen, T. Larsen. "Transmitter Architecture Based on $\Delta\Sigma$ Modulation and Switch-Mode PA". *IEEE Trans. on Circuits and Systems II*, 2007, vol. 54, no. 8, pp. 735-739.
- [14] A. Diet et al. "EER architecture specifications for OFDM transmitter using a class E PA" *IEEE MWCL*, V14 18, 2004, pp 389-391.
- [15] A. Diet et al. "Front end accordability for cognitive multi-radio, using a class E HPA and a multi-band antenna". *Asia Pacific Microwave Conference, APMC 2008, dec., Hong Kong, China*.
- [16] F. Robert et al. "Study of a polar $\Delta\Sigma$ transmitter associated to a high efficiency switched mode amplifier for mobile Wimax". *10th annual IEEE Wireless and Microwave Technology Conference, WAMICON, april 2009, Clearwater, FL, USA*.
- [17] M.-L. Suarez Peñaloza, F. Robert, M. Villegas, G. Baudoin, A. Diet. "Influence of the Envelope coding on a Class E Amplifier Efficiency in Polar Architecture" *European conference on Wireless Technology, EuMW/EuWiT, 28th Sept. - 2nd Oct. 2009, Roma, Italia*.
- [18] A. Diet, M. Villegas, G. Baudoin, F. Robert. "A Methodology for multi-band class E RF PA design." *IEEE International Microwaves Workshops Series on "RF front ends for SDR and Cognitive Radio Solutions" IMWS 2010, 22-23 february, Aveiro, Portugal*.