



HAL
open science

Multi-domain industrial benchmarks for eddy-current modelling: the COFREND working group

Michel Mayos, Thierry Sollier, Marc Lambert, Catherine Gilles-Pascaud, Olivier Moreau, Marc Dessendre, François Deneuille, Christophe Reboud, Fabrice Foucher, Quentin Mistral, et al.

► **To cite this version:**

Michel Mayos, Thierry Sollier, Marc Lambert, Catherine Gilles-Pascaud, Olivier Moreau, et al.. Multi-domain industrial benchmarks for eddy-current modelling: the COFREND working group. 10th European Conference on Non-Destructive Testing (ECNDT 2010), Jun 2010, Moscou, France. pp.4.5.23. hal-00536052

HAL Id: hal-00536052

<https://hal.science/hal-00536052>

Submitted on 15 Nov 2010

HAL is a multi-disciplinary open access archive for the deposit and dissemination of scientific research documents, whether they are published or not. The documents may come from teaching and research institutions in France or abroad, or from public or private research centers.

L'archive ouverte pluridisciplinaire **HAL**, est destinée au dépôt et à la diffusion de documents scientifiques de niveau recherche, publiés ou non, émanant des établissements d'enseignement et de recherche français ou étrangers, des laboratoires publics ou privés.

MULTI-DOMAIN INDUSTRIAL BENCHMARKS FOR EDDY CURRENT MODELING: THE COFREND WORKING GROUP

Michel MAYOS¹, Thierry SOLLIER², Marc LAMBERT³, Catherine GILLES-PASCAUD⁴, Olivier MOREAU⁵, Marc DESSENDRE⁶, François DENEUVILLE⁷, Christophe REBOUD⁴, Fabrice FOUCHER⁸, Quentin MISTRAL⁹, Mikaël DEBROISE¹⁰, Robert LEVY¹¹

¹ EDF/CEIDRE, Saint Denis, France, ² IRSN, Fontenay-aux-Roses, France,

³ CNRS/L2S, Gif-sur-Yvette, France, ⁴ CEA/LIST, Saclay, France,

⁵ EDF R&D/THEMIS, Clamart, France,

⁶ DASSAULT AVIATION - DGIA/CDE, Argenteuil, France,

⁷ VALLOUREC/CEV, Aulnoye-Aymeries, France, ⁸ CEDRAT, Meylan, France,

⁹ SNECMA, Evry, France, ¹⁰ AREVA, Chalon-sur-Saône, France, ¹¹ COFREND, Paris, France

1. Introduction - A need for industrial benchmarks on NDE modeling

The use of simulation tools in non-destructive examination in general, and in eddy current testing in particular, has been dramatically increasing in the past decade and is now rather common in many industrial applications.

Expected benefits of modeling are:

- a better comprehension of the involved physical phenomena and their influence on the results of the examination,
- a help to the qualification and performance demonstration of NDE applications through parametric studies, allowing a wider coverage of the influential parameters and a reduction of the number of mock-ups and experimental trials,
- a support to expertise in difficult testing situations.

Nonetheless, before applying a modeling tool to an industrial NDE application, it is essential to know its ability to account correctly for the actual testing situation, and, thus, to validate it on specific representative cases. For example, modeling is now currently used in the performance demonstration during the mandatory formal qualification of NDE applications for the inspection of nuclear power plants in France, and, in this case, validation of the simulation tools that have been used is explicitly required [1] [2].

A typical mode of operation for code validation would be as follows:

- Being given a NDE application, define specific benchmarks through test cases reproducing the field NDE situation for the parameters to be considered;
- Get reference data on these test cases, either experimental or simulated with an already validated code;
- Select one or several codes to be evaluated and solve the specific benchmarks;
- By comparison with reference data and qualification requirements, decide whether the code can be used in the qualification process;
- Do the parametric study within a range of variation of influential parameters covered by the specific benchmarks.

Concerning eddy currents, numerous simulation codes are now commercially available or under development. These codes are extremely variable in formulation and complexity: they can range from very simplified analytic to full-3D finite element formulations, with a considerable variety of intermediate combinations. Furthermore, according to his company's particular knowledge, the NDE end-user may or may not be familiar with the specific abilities of a given code to solve his problem. Anyway, in many cases, the candidate code may appear as a "black box" to him. It can then be difficult to make a first selection between codes to perform a full validation study, and a need for simpler test cases is expressed by the end-user.

Academic benchmark problems from the literature have been used in a first step, but they have proven in several occasions to be unfit to the representation of actual industrial situations. References [2] and [3] give an example where an apparently simple case (a through-wall notch in a tube) could not properly be described by a code that had been formerly validated on an academic benchmark, due to the numerical singularity arising from the non simply-connected topology of the testing situation. These kind of experience originated a need to define generic benchmarks representative of actual industrial situations.

2. Constitution of a Working Group

The concern for defining benchmark problems focused on actual industrial issues is shared by the whole French NDE community and has led to the creation of a dedicated working group (WG) in the frame of COFREND (the French Confederation for Non-Destructive Examinations) [4]. WG members cover a wide range of profiles of companies involved in NDT: industrial users - nuclear (AREVA, EDF), aerospace (Dassault, EADS, SNECMA), steel industry (Vallourec), automotive (Renault) -, government / nuclear safety (IRSN), research/academic (CEA, Supelec/CNRS, Ecole Centrale Lyon), code developers (CEDRAT), NDE vendors (Alphatest, Zetec).

After a first phase leading to the organization of a Technical Symposium dedicated to modeling in eddy current NDE, held in Paris on October 19, 2004, the WG has been focusing on the definition and resolution of industrially-oriented benchmark problems since the beginning of 2005. This orientation came as the main technical concern expressed by the attendees of the 2004 Symposium. Since then, the WG has been working on a regular basis of 1 to 2 annual meetings, gathering between 10 and 15 participants at each time.

3. Benchmark definition

The ultimate purpose of COFREND benchmarks is to be used as generic benchmarks that represent a first step in code selection before being applied to more specific case problems in the resolution of the true industrial need. They are meant to be of public access and to represent a reference for computing codes looking for performance evaluation in eddy current NDE applications.

The first task achieved by the WG was to define the characteristics a test case has to fulfill to qualify as a generic benchmark. They are as follows:

- **Realistic:** inspired by actual industrial issues,

- **Simple:** the benchmark can easily be processed by a wide range of candidate codes and addresses only a given industrial problem at a time (e.g. defect shape regardless of geometry),
- **Complete:** full description of the benchmark is available: geometry, material properties, probe, defects and discontinuities, trajectory of probe vs. tested component, required outputs of the benchmark problem,
- **Public:** no proprietary data (probes, materials, defects,...) are involved in the benchmark description,
- **Verifiable:** reference data (experimental or simulated) exist for validation.

The respect of all these characteristics is critical to validate a test case as a COFREND benchmark. Their definition came after learning from experience. For example, one of the early benchmarks (known as problem 1) had to be turned down, because the data had been acquired with a commercial probe, the descriptive parameters of which could not be made public.

So far, 6 benchmarks have been fully defined or are under description finalization, and 2 projects are under study.

- **Fully-defined benchmarks**

Problem 2: Nickel alloy thin plate with notches (proposed by EDF and CEA)

This problem's industrial origin is the inspection of steam generator tubes by eddy current rotating probe. It is motivated by the numerical difficulties arising from the presence of through-wall defects (cf. [2]-[3]).

The test-case consists of the inspection of 2 plates (thicknesses 1.55 mm and 1.27 mm) in alloy 600 on which notches of various depths and lengths have been machined (cf. Fig. 1). These notches are surface-breaking on one side of the plate. The plate can be turned over to simulate the inspection of outer diameter defects on a tube. The probes are generic laboratory absolute surface probes : one combined transmit-receive and one separate transmit-receive.

It can be observed that, from the actual industrial problem, only the features of through-wall, OD or ID defects and of the behavior of separate or combined transmit-receive probes have been kept. Tube geometry and probe design, which can bring irrelevant additional computing difficulties, have not been considered.

Problem 3: Variable-shaped defects in bore hole (proposed by Dassault Aviation)

This problem's industrial origin is the detection of fatigue cracks in bore holes on aeronautic components using a surface probe.

The test-case bears on the inspection of a hollow aluminum mock-up simulating a structure with a bore hole and containing notches, located either linearly in the bore hole (semi-circular profile) or at the upper and lower corners (quarter-circular profile) (cf. Fig. 2).

Problem 6: Off-centered encircling probe around tube (proposed by Vallourec)

This problem's industrial origin is the on-line testing of stainless steel tubes upon manufacturing, using an encircling probe.

The test case describes the inspection of a stainless steel 304L tube containing holes with a separate transmit-receive differential encircling probe which can undergo an eccentricity from the tube axis (cf. Fig.3).

Preliminary simulation results can be seen in [5]

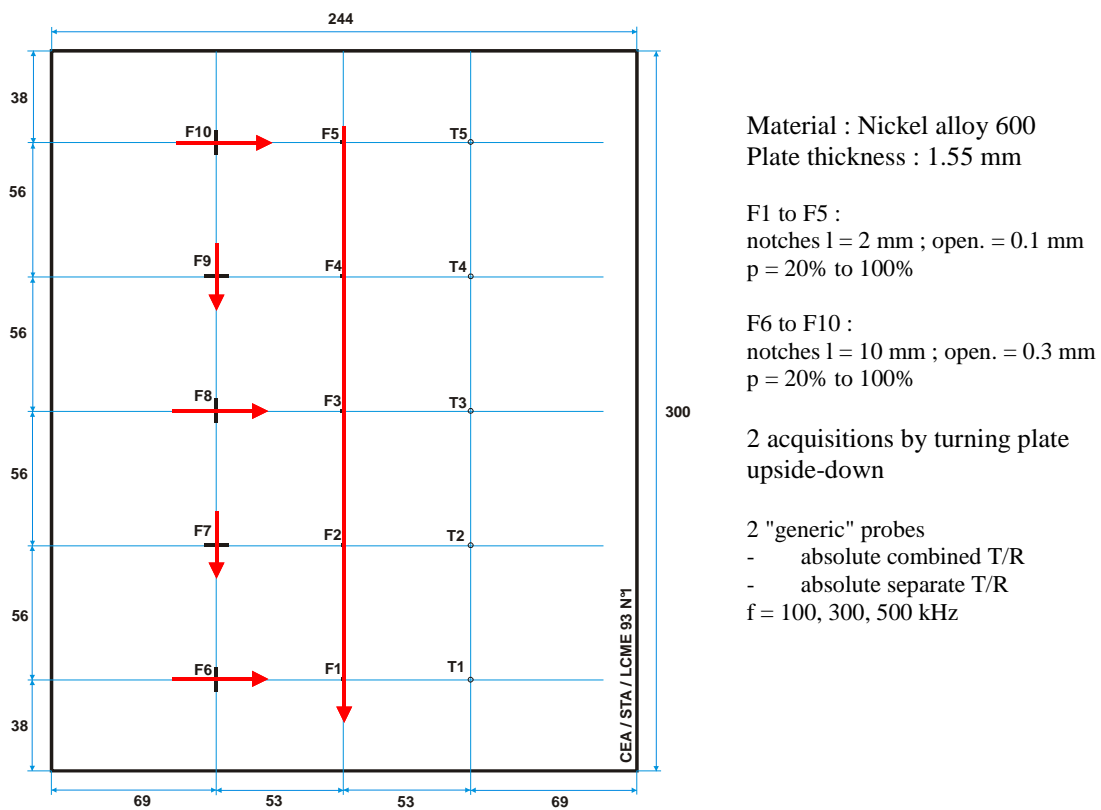

Figure 1: Descriptive data from test-case no. 2 (plate no.1)
Additional data available on a second plate (1.27 mm thick) with slightly different defects (longer notches)

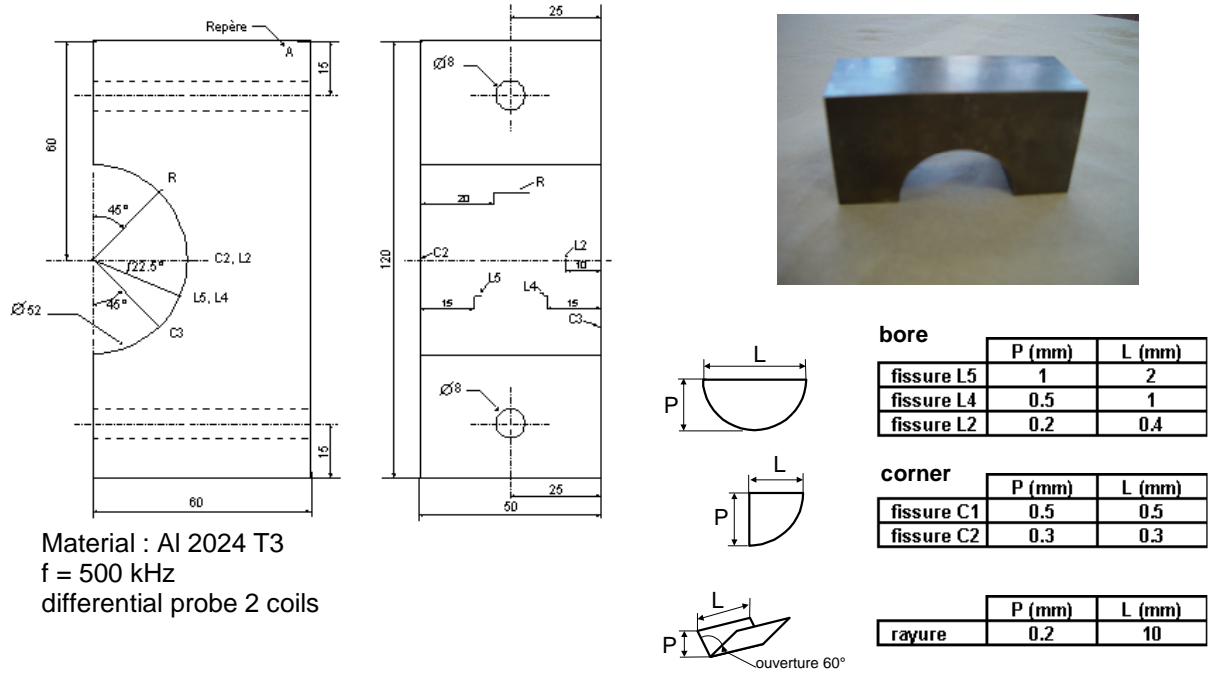
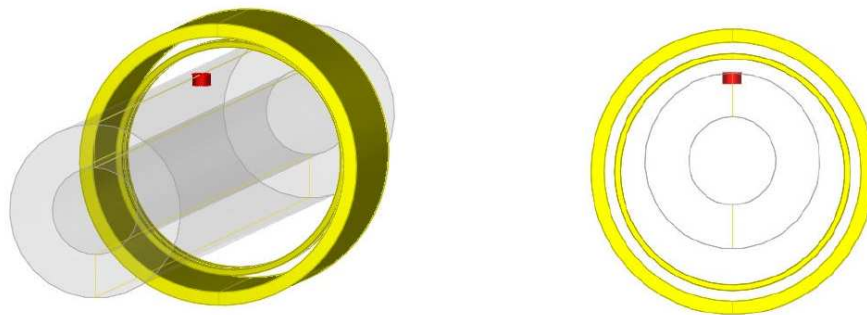
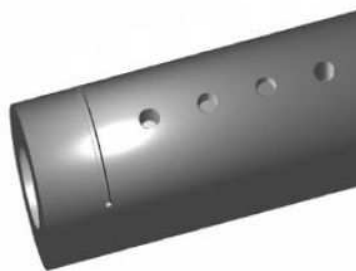

Figure 2: Descriptive data from test-case no. 3



Tube: material: stainless steel (304L)
 ext. diameter: 32 mm, thickness: 8 mm
 Probe: encircling, separate T/R, differential R
 f = 50 kHz
 Maximum eccentricity of probe from tube axis: 2 mm



Defects : 4 holes \varnothing 3.5 mm

- through-wall
- depth 2 mm
- depth 3 mm
- depth 5 mm

Figure 3: Descriptive data from test-case no. 6

- **Benchmarks under description finalization**

Problem 4: Cracks on rivet edges (proposed by EADS and Dassault Aviation)

This problem is inspired by the NDE of riveted assemblies in the aerospace industry, according to the representation in Figure 4. This test-case is now under more precise definition.

Problem 5: Double-layered structure with variable gap between layers (proposed by CEA and Supelec/L2S)

This problem has the same industrial origin as problem 4.

The test-case concerns the influence of an intra-layer decohesion on the eddy current response to a given defect (cf. Fig. 5). The defect (a hole) and the probe (a single absolute coil) are voluntarily chosen very simple. The multi-layer structure consists of a 4 mm-thick aluminum plate and of a 1.27 mm-thick nickel alloy 600 with a variable gap (0 to 50 μm).

The description of this problem is almost complete and experimental reference data are available. Preliminary simulation results can be seen in [6].

Problem 7: Detection of small defects in a plate with a pencil probe (proposed by SNECMA)

This problem is originated by the design and development of small eddy current probes to examine mechanical components of aeronautic motors (can concern automotive industry as well).

The test-case describes the examination of a stainless steel plate containing small parallelepipedal notches ($0.8 \times 0.1 \times 0.4 \text{ mm}^3$ to $0.1 \times 0.1 \times 0.1 \text{ mm}^3$) with 2 different probes: a "commercial" probe (outer diameter $< 3 \text{ mm}$) and a "pencil" probe.

The description of the problem is almost complete and experimental data are available (cf. fig. 6).

- **Projects for new benchmarks**

Significant work has been started on the definition of 2 new benchmarks:

- non-magnetic tube with ferromagnetic support plate (problem 8) - Industrial origin: heat exchanger tube inspection (nuclear),
- remote field eddy current inspection of a ferromagnetic tube (problem 9) - Industrial origin: multi-domain applications of the technique, including detection of flow-accelerated corrosion on ferromagnetic heat exchanger tubes.

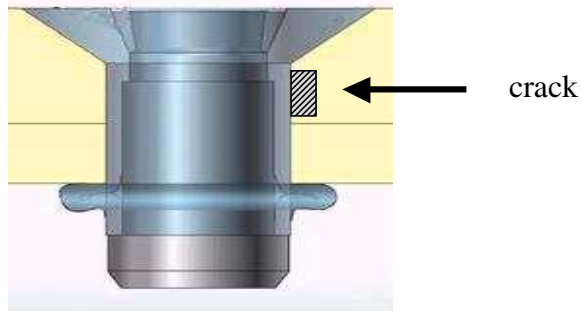

Figure 4: Industrial origin of test-case no. 4 (crack on edge of riveted assembly)

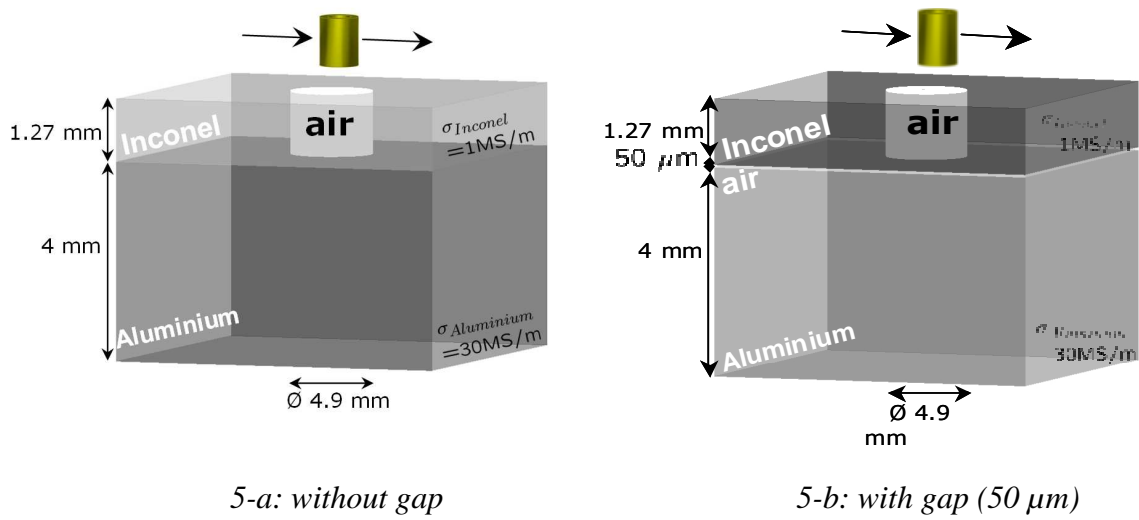

Figure 5: Description of test-case no. 5 (2-layered structure with variable gap)

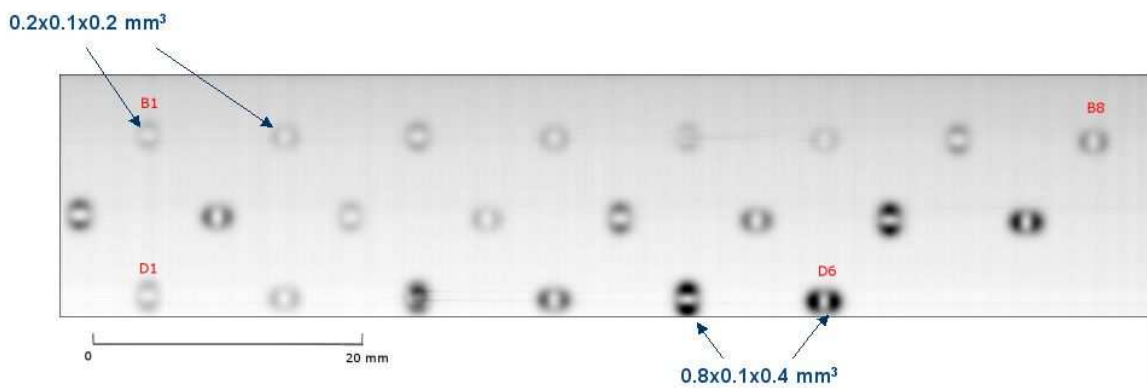

Figure 6: Test-case no. 7 : experimental data (C-scan)

4. Example of benchmark resolution

Test-case no. 2 (cf. §3) has been processed with 3 different codes, involving members of the Working Group:

- **CIVA:** CIVA is a commercial multi-technique (ultrasonics, radiography, eddy current) platform developed by CEA, dedicated to NDE and including modeling tools. The eddy current simulation module is a "simplified" semi-analytic code using the Volume Integral Method (VIM) based on Green's formalism. The CIVA model allows relatively quick calculations, which, for example, permit to obtain rather easily full C-scan data.
- **Code_CARMEL 3D:** Code_CARMEL 3D is a Finite Element academic code developed by LAMEL, which is a common laboratory between EDF R&D Division and University of Lille, focused on electromagnetic applications. It is bound to become a free commercial code. The code includes two dual formulations, $\mathbf{A}\text{-}\varphi$ and $\mathbf{T}\text{-}\Omega$, each having its own advantages and disadvantages [7].
- **FLUX 3D:** FLUX 3D is a commercial, general purpose electromagnetic Finite Element code, including a NDT module [8]. It is commercialized in France by the CEDRAT company.

Table 1 gives the comparison of the results obtained on one of the defects of plate no. 1 (see Figure 1), notch F5: through-wall, 2 mm length, 0.1 mm opening. The values of the maximum signal in amplitude and phase for a scan over the defect with the combined transmit-receive probe are given.

Typically, very good agreement is observed between experimental and simulated data, demonstrating the ability of all 3 codes to handle correctly the specificity of the through-wall notch. A look at deviations shows that, as it could be expected, a better agreement is obtained with finite element codes than with the semi-analytic one, but this is counterbalanced by the difficulty of calculation and the computing time. The quantitative data obtained give the end-user a hint about the better compromise between cost and simulation accuracy, according to his own requirements.

		Exp.	CIVA		Code_CARMEL 3D		FLUX 3D	
				<i>deviation</i>		<i>deviation</i>		<i>deviation</i>
100 kHz	Amplitude	0.380 Ω	0.364 Ω	4.2%	0.387 Ω	1.8%	0.404 Ω	6.3%
	Phase	142.7°	140°	2.7°	141.2°	1.5°	139.1°	3.6°
300 kHz	Amplitude	1.822 Ω	1.667 Ω	8.5%	1.819 Ω	0.2%	1.82 Ω	0.1%
	Phase	113.2°	109.7°	3.5°	113.3°	0.1°	112.0°	1.2°

Table 1: Test-case no. 2 : Comparison of experimental and simulated data (3 different codes)

More complete comparative data are shown on figures 7 and 8. Figure 7 represents the comparison between experimental data and data simulated with CIVA on a full C-scan over notch F5. It can be observed that the agreement between both remains very good for every relative position of the probe with respect to the notch (note that the colour scale is the same for both representations). Figure 8 shows a comparison between experimental and simulated data for all three codes on the impedance plane signatures for a linear scan. Once again, an excellent agreement is observed.

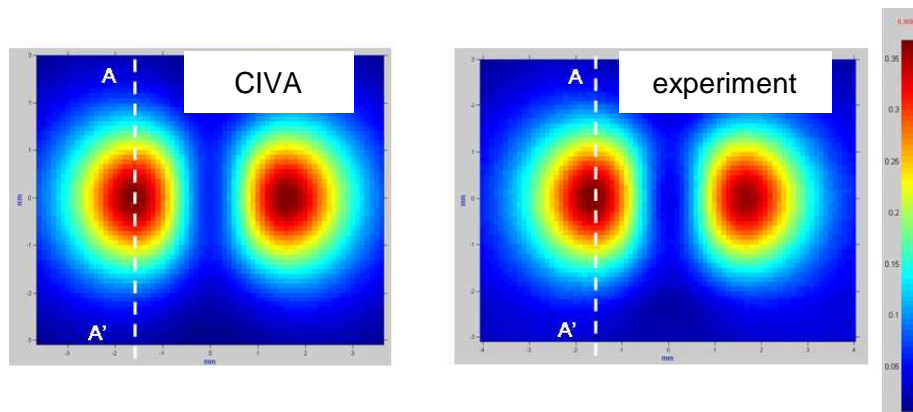

Figure 7: Comparison of experimental and simulated C-scans - Notch F5 - $f = 100$ kHz

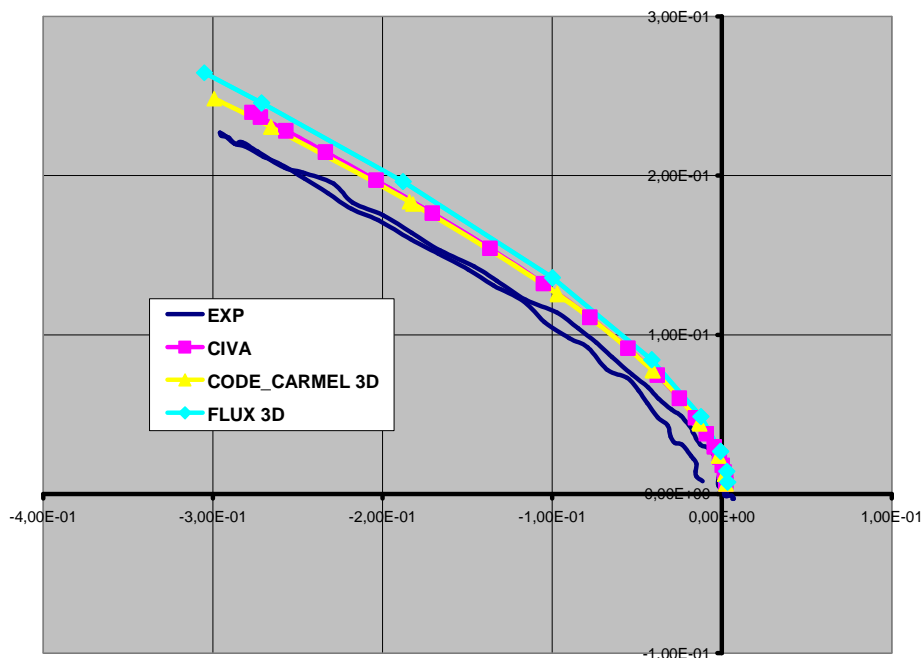

Figure 8: Comparison of experimental and simulated impedance plane signatures
Notch F5 - $f = 100$ kHz - Linear scan perpendicular to notch (AA')

5. Conclusions and future actions

The COFREND Group work has now reached a significant state of development: 3 benchmark problems of industrial origin are fully-described, 3 more will soon be available (2 of them in a very short time), and 2 new projects can be ready within a one-year horizon. The description of the test-cases is still perfectible, and the WG is currently working on it.

The benchmark problems cover the concerns of several industrial branches (aerospace, nuclear, steel industry, automotive industry, NDE vendors), and address different physical problems: defect topology, defect location, component geometry, influence of a gap, influence of probe position, small probes, ferromagnetic materials... A panel of resolutions, implying

French code users and developers, begins to appear. The examples shown already demonstrate the interest of the approach for all participants.

Obviously, the purpose of such benchmarks is to be widely shared, on the user side as well as on the calculator side. This means that the WG's concern is to open its list of benchmarks to resolution worldwide, and to increase its panel of case-tests by exchanging and mutualizing the original COFREND cases with international benchmarks having a similar approach.

Benchmark description is available on the COFREND Internet site: <http://www.cofrend.com/modelisationcf/>.

6. References

- [1]. M. MAYOS, A. LE BRUN, J.M. CARPREAU, Ø. BREMNES, C. POIDEVIN, T. SOLLIER: "The use of modelling in support of the qualification of NDE application", *4th International Conference on NDE in relation to structural integrity for nuclear and pressurized components*, London, December 2004.
- [2]. M. MAYOS, O. MOREAU, V. COSTAN, C. GILLES-PASCAUD, C. REBOUD, F. BUVAT : "A Benchmark-based Approach For The Validation Of Eddy Current Simulation Codes In Support Of Nuclear Power Plants Inspection" - *ENDE 2009 Conference*, Dayton, July 2009.
- [3]. A. SCHUMM, G. PICHENOT, M. MAYOS: "Simulation code validation targeting steam generator inspection with eddy current probes", *5th Int. Conference on NDE in relation to structural integrity for nuclear and pressurized components*, San Diego, May 2006.
- [4]. M. MAYOS, M. LAMBERT, C. GILLES-PASCAUD, M. DESSENDRE, N. DOMINGUEZ, F. FOUCHER, A. ABAKAR: "COFREND Working Group on eddy current NDE simulation - Review of activities", *Journées COFREND 2008*, Toulouse, May 2008.
- [5]. C. REBOUD, D. PREMEL, G. PICHENOT, D. LESSELIER, B. BISIAUX: "Development and validation of a 3D model dedicated to eddy current non destructive testing of tubes by encircling probes", *International Journal of Applied Electromagnetics and Mechanics*, 2007 - 25 pp. 313-317
- [6]. S. PAILLARD, G. PICHENOT, M. LAMBERT, H. VOILLAUME "Eddy current modelling for inspection of riveted structures in aeronautics", in *"Electromagnetic Non-Destructive Evaluation (X)"*, S. Takahashi & H. Kikuchi ed., IOS Press, Amsterdam, pp. 25-32, 2007.
- [7]. O. MOREAU, F. BUVAT, C. GILLES-PASCAUD, C. REBOUD: "An approach for validating NDT eddy current simulation codes", *7th International Conference on NDE in relation to structural integrity for nuclear and pressurized components*, Yokohama, May 2009.
- [8]. Y. LE FLOCH, F. FOUCHER, J.C. VÉRITÉ, C. GUERIN, R. RUIZ, X. BRUNOTTE, A. PERREGAUX: "Non-destructive testing modeling with Finite Element Method (Problem 8)", *ENDE 2004*, East Lansing, June 2004.