



HAL
open science

Identification and comprehensive characterization of large genomic rearrangements in the and genes

Jesús Valle, Lúdia Feliubadaló, Marga Nadal, Alex Teulé, Rosa Miró, Raquel Cuesta, Eva Tornero, Mireia Menéndez, Esther Darder, Joan Brunet, et al.

► **To cite this version:**

Jesús Valle, Lúdia Feliubadaló, Marga Nadal, Alex Teulé, Rosa Miró, et al.. Identification and comprehensive characterization of large genomic rearrangements in the and genes. *Breast Cancer Research and Treatment*, 2009, 122 (3), pp.733-743. 10.1007/s10549-009-0613-9 . hal-00535410

HAL Id: hal-00535410

<https://hal.science/hal-00535410>

Submitted on 11 Nov 2010

HAL is a multi-disciplinary open access archive for the deposit and dissemination of scientific research documents, whether they are published or not. The documents may come from teaching and research institutions in France or abroad, or from public or private research centers.

L'archive ouverte pluridisciplinaire **HAL**, est destinée au dépôt et à la diffusion de documents scientifiques de niveau recherche, publiés ou non, émanant des établissements d'enseignement et de recherche français ou étrangers, des laboratoires publics ou privés.

Identification and comprehensive characterization of large genomic rearrangements in the *BRCA1* and *BRCA2* genes

Jesús del Valle · Lúdia Feliubadaló · Marga Nadal · Alex Teulé · Rosa Miró · Raquel Cuesta · Eva Tornero · Mireia Menéndez · Esther Darder · Joan Brunet · Gabriel Capellà · Ignacio Blanco · Conxi Lázaro

Received: 26 August 2009 / Accepted: 20 October 2009 / Published online: 6 November 2009
© Springer Science+Business Media, LLC. 2009

Abstract Large genomic rearrangements are estimated to account for approximately 5–10% of all disease-causing mutations in *BRCA1* and *BRCA2* genes in patients with hereditary breast and ovarian cancer syndrome (HBOC). We use MRC-Holland Multiplex Ligation-dependent Probe Amplification (MLPA) to screen for such rearrangements in patients with HBOC and as a first step in our genetic testing workflow. The technique was applied to a set of 310 independent patients and detected eight different copy number alterations, corresponding to 2.6% of the studied samples. MLPA was also found to identify point mutations located in probe sequences. As commercial MLPA tests are not suitable for determining the specific breakpoints or for defining the exact extent of rearrangements, we applied a set of different complementary techniques to characterize these

genetic alterations with greater precision. Long-range PCR amplification, RNA analysis, SNP-array chips, non-commercial MLPA probes, and FISH analysis were used to fully define the extent and mechanism of each alteration. In *BRCA1*, six rearrangements were characterized: deletion of E22, duplication of E9–E24, deletion of E16–E23, deletion of E1–E13, deletion of E1–E2 and duplication of E1–E2. In *BRCA2*, we studied a deletion of E15–E16 and a deletion of E1–E24. To the best of our knowledge, this is the most comprehensive study of the nature and underlying molecular causes of these mutational events in the *BRCA1/2* genes.

Keywords *BRCA1* · *BRCA2* ·

Large genomic rearrangement · Cancer diagnostics · MLPA · Breast cancer · Ovarian cancer

J. del Valle · L. Feliubadaló · M. Nadal · R. Cuesta · E. Tornero · M. Menéndez · G. Capellà · C. Lázaro (✉)
Programa de Diagnòstic Molecular de Càncer Hereditari,
Laboratori de Recerca Translacional, Institut Català
d'Oncologia-IDIBELL, Hospital Duran i Reynals,
Hospitalet de Llobregat, Gran Via s/n, km 2.7,
L'Hospitalet de Llobregat, 08907 Barcelona, Spain
e-mail: clazaro@iconcologia.net

A. Teulé · I. Blanco
Programa de Consell Genètic en Càncer, Institut Català
d'Oncologia, Hospitalet de Llobregat-IDIBELL,
Barcelona, Spain

R. Miró
Institut de Biotecnologia i Biomedicina, Departament de
Biologia Cel·lular, Fisiologia i Immunologia, Facultat de
Medicina, Universitat Autònoma de Barcelona, Barcelona, Spain

E. Darder · J. Brunet
Programa de Consell Genètic en Càncer, Institut Català
d'Oncologia, Girona-IdIBGi, Girona, Spain

Introduction

Germline mutations in *BRCA1* and *BRCA2* predispose to high risk of breast and ovarian cancer [1, 2]. Inherited mutations in cancer susceptibility genes account for approximately 5–10% of all breast and ovarian cancers, with a large proportion of mutations found in families with several affected patients over multiple generations [3, 4]. For accurate risk assessment in members of families with a high incidence of breast/ovarian cancer, it is very important to identify the specific molecular alteration responsible for the Hereditary Breast and Ovarian Cancer (HBOC) Syndrome. Most reported germline pathogenic mutations are nonsense substitutions and small deletions/insertions causing truncation of *BRCA1/2* proteins (Breast cancer Information Core database, www.nhgri.nih.gov/Intramural_research/Lab_transfer/Bic). However, it should be noted that the technical limitations of traditional point mutation

detection approaches cause large genomic rearrangements (exon deletion(s) and/or duplication(s)) to be overlooked. Appropriate methodologies for the detection of large intragenic deletions and duplications have shown that these alterations are present in a substantial number of carriers of different genetic disorders [5]. In recent years, multiplex ligation-dependent probe amplification (MLPA) has emerged as a powerful and reliable method for detecting deletions or duplications of one or more exons [6], leading to increased identification of large genomic rearrangements in *BRCA1/2* in the literature [7–11]. The frequency of large genomic rearrangements affecting the *BRCA* genes varies among populations, which is probably a reflection of founder effects but also results from the different clinical cut-offs used in mutational analysis of the *BRCA* genes in each of the studies. For example, two different genomic rearrangements in the *BRCA1* gene account for 23% of mutation-positive families in Holland [12], whereas this mutation type has never been detected in Canada [13]. To date, more than 170 genomic rearrangements have been reported in *BRCA1* and about 30 in *BRCA2* [7–11, 14].

One mechanism which could originate large genomic rearrangements is the unequal homologous recombination between short interspersed nuclear elements (SINEs), including Alu repeats, long interspersed nuclear elements (LINEs), or simple repeat sequences with a high degree of homology [5]. The difference in the incidence of rearrangements between *BRCA1* and *BRCA2* could be due to differences in the genomic architecture surrounding these genes. Therefore, the higher number of rearrangements found in *BRCA1* could be due to the presence of a *BRCA1* pseudogene upstream of *BRCA1* or to a higher percentage of repetitive elements (Alu repeats) in the gene.

In Spain, the frequency of large rearrangements affecting the *BRCA1* gene has been estimated at around 1.4–1.6% of unselected cases [15, 16], with a prevalence of 2% in cases previously testing negative for *BRCA1/2* point mutations [16, 17]. The prevalence of large rearrangements in *BRCA2* varies from 0% in unselected cases [15] to 1.5% [18] in cases previously testing negative for *BRCA1/2* point mutations.

Here, we present the use of MLPA to search for large rearrangements in 310 patients belonging to 310 independent families as a first step in our algorithm for detecting germline *BRCA1/2* mutations. As commercial MLPA tests are not suitable for determining the specific breakpoints or for defining the exact extent of the rearrangements, we applied a set of different complementary techniques to characterize the genetic alterations detected in our study with greater precision. The study was designed to confirm the prevalence of large genomic rearrangements in *BRCA1/2* in Spanish high-risk breast/ovarian cancer families and to characterize them at the molecular level by determining their extent, identifying their breakpoints and, when

possible, characterizing the impact of the genomic alteration on the correct splicing of the gene. Taken together, the information obtained improved our understanding of the nature, frequency, and underlying molecular mechanisms of these genetic events.

Materials and methods

Patients and samples

Samples from 310 affected proband cases from 310 independent families were referred for *BRCA1/2* mutation analysis under the ICO Cancer Genetic Counselling Program. The criteria for entry into the mutational study were defined in accordance with Catalan guidelines for genetic testing of HBOC (www.gencat.cat/salut/depsan/units/aatrm/pdf/og0601es.pdf). They can be summarized as the presence of any of these cases: (1) three or more first-degree relatives with breast/ovarian cancer; (2) two first-degree relatives as follows—two ovarian cancers, one ovarian cancer and one breast cancer, one male breast cancer and one breast/ovarian cancer, two breast cancer both below 50 years old, or one bilateral breast cancer and one breast cancer (one below 50 years old); (3) breast cancer diagnosed before 30 years old; (4) breast and ovarian cancer in the same patient; and (5) bilateral breast cancer diagnosed before 40 years old.

Genomic DNA was extracted from peripheral blood lymphocytes using the FlexiGene DNA Kit (Qiagen GmbH, Hilden, Germany). Informed written consent was obtained from all patients included in the study and the study protocol was approved by the Ethics Committee of our Institution.

Screening for rearrangements by multiplex ligation-dependent probe assay (MLPA)

MLPA was performed as described by Schouten et al. (2002) on genomic DNA. Genomic rearrangements in *BRCA1* and *BRCA2* were analyzed using MLPA commercial kits # P002 and P087 for *BRCA1* and P045 for *BRCA2* (MRC-Holland, Amsterdam, The Netherlands). PCR products were analyzed on an ABI 3100 capillary sequencer using GeneMapper software (Applied Biosystems, Foster City, CA, USA). The proportion of each peak relative to the height of all peaks was calculated for each sample and then compared to proportions for the corresponding peak averaged for a set of at least ten normal DNA samples. Ratios of 1.0 ($\pm 20\%$) were treated as normal copy number. Ratios of 0.5 were considered as deletions and ratios of 1.5 as duplications. Each positive result was confirmed in a second independent MLPA reaction.

In order to better characterize the rearrangements uncovered by commercial MLPA kits, we designed several MLPA probes according to the instructions provided by MRC-Holland (www.mrc-holland.com/pages/support_desing_synthetic_probepag.html) (probe sequences available upon request). Unique sequences were identified using the BLAT program from UCSC (www.genome.ucsc.edu), and care was taken to avoid the presence of known sequence variants in the probe annealing site (www.ensembl.org). Probes were designed to produce PCR products differing by 3 bp in length to allow correct separation by size. Oligonucleotides were ordered from Sigma (Sigma–Aldrich, Haverhill, UK). MLPA reaction was performed as described previously [6]. The signal of each probe was adjusted after visual examination of preliminary results by raising or lowering the concentration in the probe-mix.

Breakpoint analysis and long-range PCR

In order to characterize the rearrangements and determine the exact site of their breakpoints, we performed long-range PCR of gDNA using the Expand Long Template PCR System or the Expand Long Range kit (Roche Diagnostics GmbH, Mannheim, Germany), according to the manufacturer's protocol. PCR products were separated on a 0.8% agarose gel and visualized by ethidium bromide staining. PCR products containing the expected rearrangement were cut from the gel and purified using GFX PCR DNA and the Gel Band Purification Kit (Illustra, GE Healthcare UK limited, Buckinghamshire, United Kingdom). Isolated PCR fragments were sequenced by walking on both strands using the Big Dye V3.1 Terminator Kit (Applied Biosystems, Forster City, CA, USA) and an automated sequencer.

The interspersed repeats in regions around the breakpoints were examined using the Repeat Masker Program (www.repeatmasker.org).

All genomic rearrangements are named according to the nucleotide number of the mRNA sequences in GenBank NM_007294.2 (*BRCA1*) and GenBank NM_000059.3 (*BRCA2*) and following the instructions provided by the HGVS (www.hgvs.org).

RNA isolation and RT–PCR

Total RNA was isolated from peripheral blood lymphocytes with TRIzol reagent (Invitrogen Life Technologies, Rockville, MD, USA). Synthesis of complementary DNA (cDNA) was performed with SuperScript II Reverse Transcriptase (Invitrogen Life Technologies, Rockville, MD, USA) using DNase-treated RNA in the presence of random primers and RNaseOUT (Invitrogen Life Technologies, Rockville, MD, USA). cDNA amplification was

performed with specific primers that encompassed the predicted rearrangement.

Fluorescence in situ hybridization

FISH was performed on chromosome spreads obtained from peripheral blood of patients. Cultures were set up from frozen lymphocytes following standard protocols. Metaphase chromosome spreads were prepared according to standard procedures. BAC clones RP11-769M9 and RP11-812O05 were obtained from the 32K BAC Rearray of the Children's Hospital & Research Center Oakland (CHORI) and kindly provided by Dr. Luis Pérez-Jurado. Probes (1 µg of each) were directly labelled by a standard nick translation reaction, hybridized in pairs, and detected using standard protocols. The FISH analysis was performed under an Olympus BX60 fluorescence microscope equipped with the appropriate filter set, and images were captured using the Cytovision software (Applied Imaging, San Jose, CA, USA).

SNP-array analysis

We used the HumanCNV370-Quad v3 BeadChip from Illumina (Illumina, San Diego, CA, USA), which assayed 373,397 tagging SNPs, to characterize the two largest rearrangements. Two hundred nanograms of genomic DNA were labelled and processed according to the manufacturer's instructions. The data were then analyzed using Illumina BeadStudio. All methods were performed as described previously [19].

Results

MLPA analysis of *BRCA1/2* genes revealed eight different rearrangements in the 310 samples analyzed (Table 1). Briefly, we identified six different large rearrangements in *BRCA1* (Fig. 1) including three novel events, whereas only two deletions were detected in *BRCA2* (Fig. 2), one of which has been described for the first time in this report. In all of the cases presented here, we confirmed the MLPA-identified alteration by applying a different experimental approach (i.e., use of a second commercial kit, home-made designed probes, large genomic PCR amplification, cDNA studies, FISH analysis, or SNP-array chip analysis), which allowed us to determine the extent of the rearrangements and the underlying molecular mechanism in most cases.

Deletion of *BRCA1* exons 1–2 was detected in a 31-year-old woman diagnosed with breast cancer at age 29 and with no family history of the disease (Fig. 3a). Rearrangements affecting these exons have been reported in many studies [7, 8, 11, 17, 20–28]. Like Hartman et al.

(2004) and Engert et al. (2008), we did not amplify the junction fragment from the genomic DNA of the patients, although we used different primer sets based on confirmed rearrangements found in other families. The extent of the rearrangement was estimated to be a maximum of ~35 kb, since our home-made probe located at 27.6 kb 5' *BRCA1* was not deleted (Fig. 1).

A novel duplication of *BRCA1*, involving exons 1–2, was found in a 35-year-old woman diagnosed with ovarian cancer at age 34 with a second-degree maternal relative affected by bilateral breast cancer at ages 60 and 68 (Fig. 3b). We confirmed this rearrangement using FISH analysis, through which we identified that the duplicated area is in the long arm of chromosome 17 and close to the *BRCA1* gene. Analysis of our home-made probe 27.6 kb 5' *BRCA1* did not reveal copy number variation (Fig. 1). We attempted to study this rearrangement at the RNA level, but were unable to amplify any mutant cDNA allele. The lack of further samples from the same family made it impossible to perform a cosegregation study.

Deletion of *BRCA1* exons 1–13 was identified in a 66-year-old woman diagnosed with two primary cancers: breast cancer at age 54 and ovarian cancer at age 61. Her

mother and one of her sisters were also diagnosed with breast cancer at ages 52 and 59, respectively (Fig. 3c). This mutation has also been described in a Finnish family with a strong history of cancer, with three cases of ovarian cancer [29]. An SNP array (HumanCNV370-Quad v3 BeadChip from Illumina) was used to determine the extent of the deletion. LogR ratios of array probes show a deletion of approximately 250 kb (Fig. 4a). MLPA analysis with our home-made probes confirmed the deletion, which includes other genes in addition to *BRCA1*, as *NBR2*, *NBR1* and *TMEM106A* (Fig. 1). MLPA also identified that the deletion breakpoint lies between exon 2 of the *ARLAD* gene and exon 6 of the *TMEM106A* gene (Fig. 4b).

A novel duplication of *BRCA1* exons 9–24 was detected in a 52-year-old woman diagnosed with breast cancer at age 49 with a second-degree paternal relative diagnosed with breast cancer at age 30. We confirmed the mutation using FISH analysis, through which we identified that the duplicated area is in the long arm of chromosome 17 close to *BRCA1* (Fig. 5). Using our home-made MLPA probes, we determined that the duplication breakpoint lies between exon 5 of the *G6PC* gene and exon 6 of the *VAT1* gene (Fig. 1). Interestingly, the patient carrying this duplication

Fig. 3 Pedigrees of the different patients harboring copy number alterations in our MLPA analysis

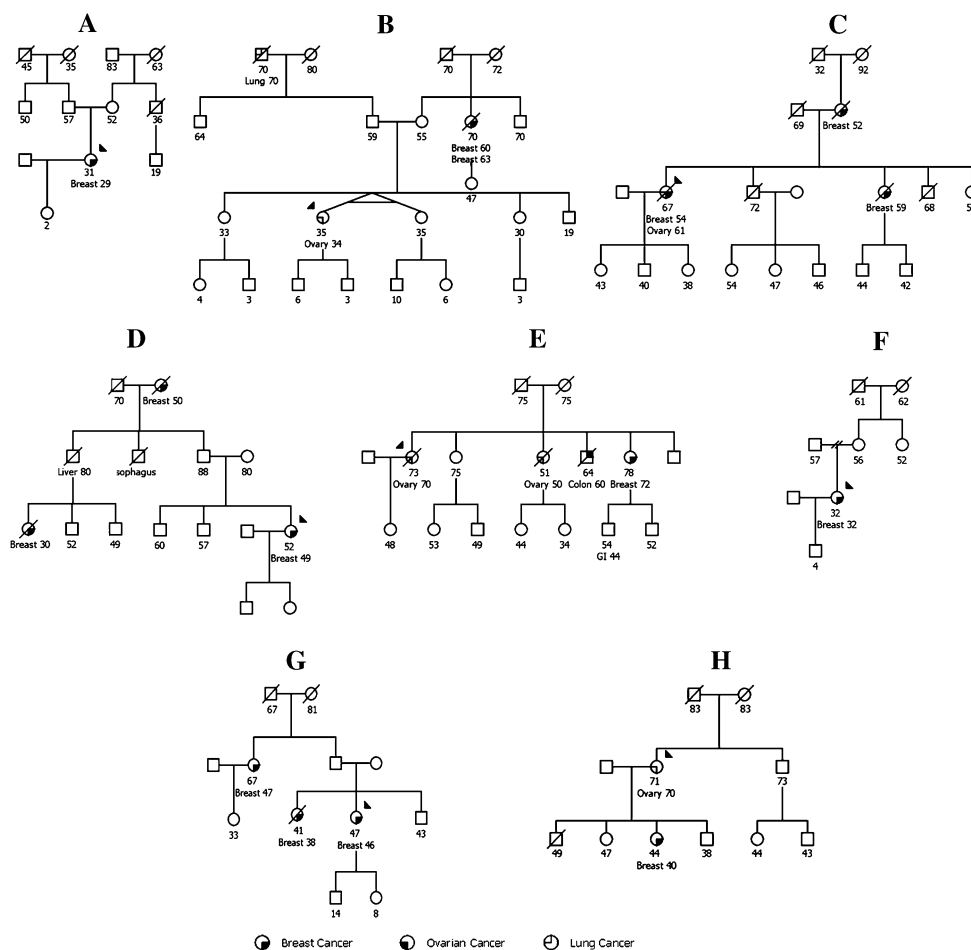

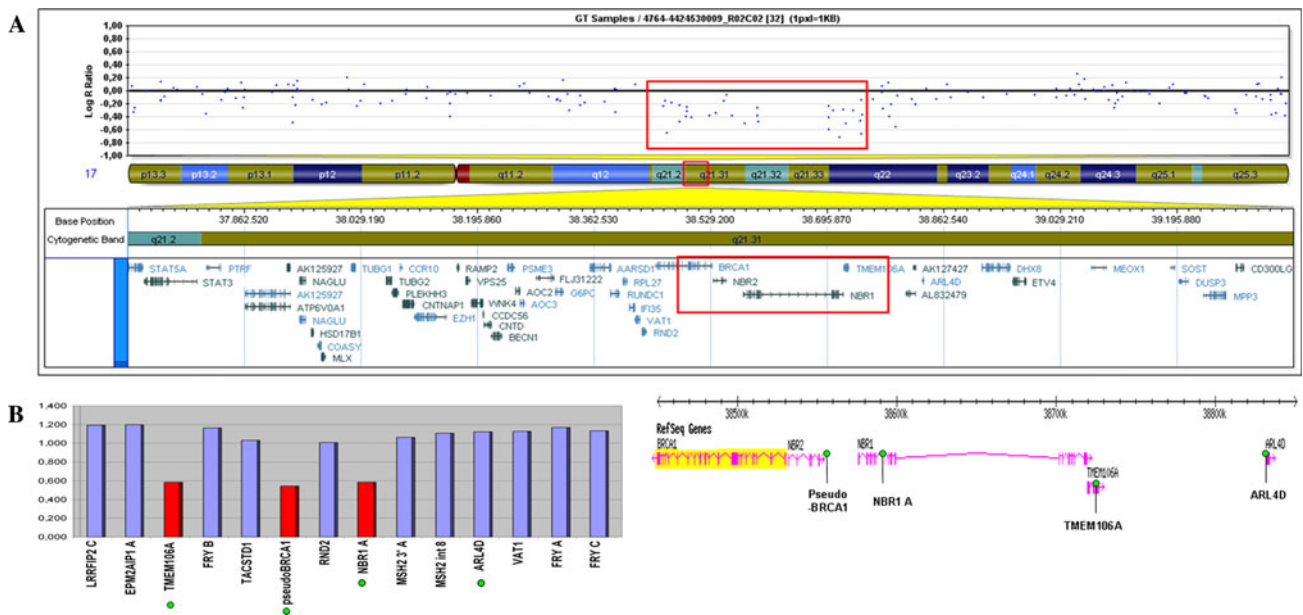

Fig. 4 Zoom-in SNP array (HumanCNV370-Quad v3 BeadChip from Illumina) and MLPA results for a patient sample with deletion of *BRCA1* exons 1–13. **a** logR ratios of array probes; deleted array probes are located inside the box. Below, a representation of the genes in and around the altered region. Results are consistent with a deletion

of approximately 250 Kb. **b** *Left*, home-made MLPA analysis from the patient confirming the deletion of Ψ *BRCA1*, *NBR1*, and *TMEM106A* probes (Y-axis: dosage quotients; X-axis: probes used); *right*, position of the home-made probes in the region

also had a clear pathogenic mutation c.68_69delAG (p.Glu23 fs) in *BRCA1*. This point mutation (also called 185delAG, and one of the most common Jewish founder mutations) has been reported 1980 times in the Breast Cancer Information Core Database (<http://research.nhgri.nih.gov/bic/>). Since we were unable to analyze more family members, we cannot determine whether the duplication and the point mutation are in the same allele.

Deletion of *BRCA1* exons 16–23 was detected in a 73-year-old woman diagnosed with ovarian cancer at age 70, with two sisters diagnosed with ovarian cancer at age 50 and breast cancer at age 70, respectively, and a brother diagnosed with colorectal cancer at age 64 (Fig. 3e). This deletion has not been reported in previous studies. Primer pairs were designed to obtain a patient-specific junction fragment, which produced a length of approximately 2.3 kb (Fig. 6a). Sequence analysis of the junction fragment confirmed a 26,794-bp deletion (c.1126+1370_1919-385del). The breakpoints are located within two interspersed elements, one AluJo and an AluSx in direct orientation (Fig. 6b). Interestingly, the crossover site lies within in a 21-bp sequence of perfect identity (Fig. 6c). These homologous regions are potentially able to form misalignments that produce subsequent non-allelic homologous recombination events, which could account for the mechanism underlying the rearrangement.

Deletion of *BRCA1* exon 22 (Fig. 7) was detected in a 32-year-old woman diagnosed with breast cancer at age 32.

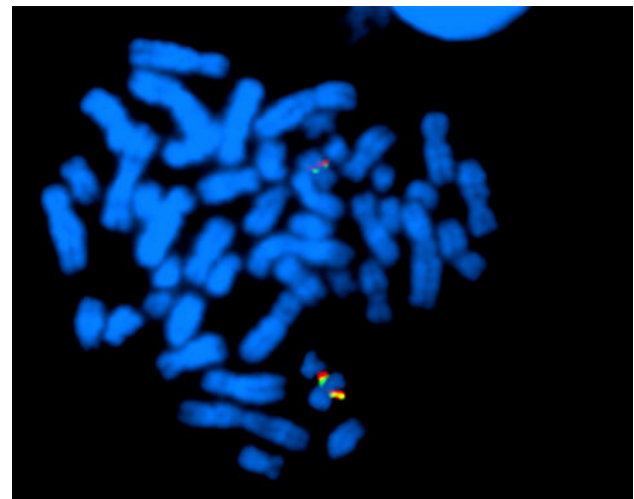

Fig. 5 FISH analysis using BAC RP11-769M9 as a probe. Image shows that one of the chromosomes 17 has an interstitial duplication

She has no known family history of breast cancer (Fig. 3f). However, it should be noted that there is no information from the paternal side of the family, who are from central Africa. This deletion has been described previously and is considered a founder mutation in Dutch breast cancer patients. We have amplified the junction fragment (Fig. 7b) and sequenced the breakpoint, confirming a 253-bp deletion c.5333-198_5387del (Fig. 7c). We were unable to detect the participation of any repetitive element in this region, and our sequencing results highlighted that this is a

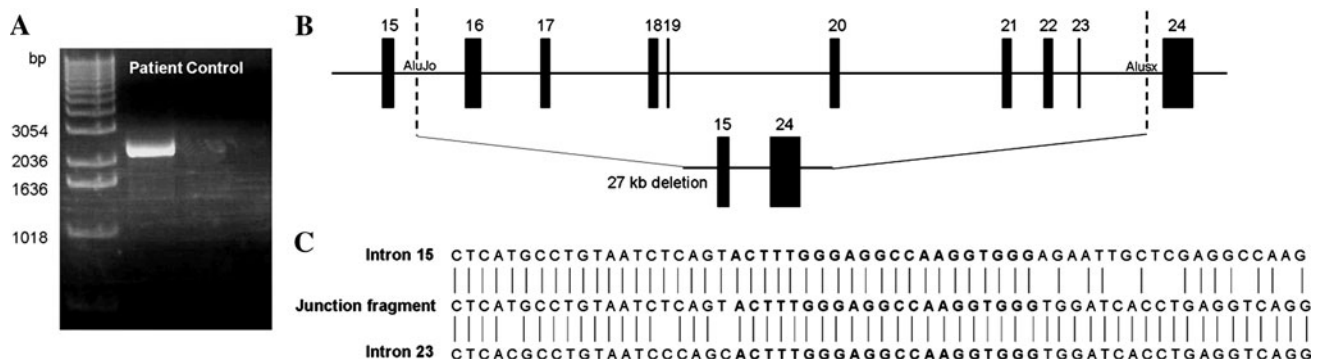

Fig. 6 PCR detection and sequence analysis of the deletion-junction fragment. **a** long-range PCR analysis with primers located in introns 15 and 24 resulted in a 2.3-kb amplicon in the patient sample but failed to amplify in a sample from a normal control. **b**: Alu-Alu

homologous recombination causes a deletion of exons 16–23. **c** alignment of sequences of intron 15 (*top*), the deletion-junction fragment (*middle*), and intron 23 (*bottom*)

novel deletion, different to the previously reported 510 bp founder deletion in a Dutch population [30]. We performed a cDNA analysis of exons 17–24, which, surprisingly, did not reveal any additional band in an agarose gel. However, when this fragment was sequenced we identified an aberrant exon formed by the insertion of part of an intronic region and part of exon 22 (r.5333_5387delins5333-260_5333-199) (Fig. 7d). This aberrant transcript will cause a frameshift which will eventually produce a putative truncated protein (p.Asp1778AlafsX54).

MLPA analysis of the *BRCA2* gene showed two large rearrangements. The first consisted of a large deletion comprising exons 1–24, which has not been reported previously. The patient harboring this deletion was a

47-year-old woman diagnosed with breast cancer at age 46 and with a family history of this disease (Fig. 3g). We also analyzed this rearrangement using a SNP array (Human-CNV370-Quad v3 BeadChip from Illumina) (Fig. 8a), which showed that the deletion encompasses most of the *FRY* gene upstream of *BRCA2*. In addition, we used different home-made MLPA probes to determine the extent of the deletion with greater precision, and found that the 5' breakpoint lies between exon 1 and exon 3 of the *FRY* gene (Fig. 8b).

The second large rearrangement identified in *BRCA2* is a deletion of exons 15–16 (Fig. 9a), found in a 71-year-old woman diagnosed with ovarian cancer at age 70 with a daughter diagnosed with breast cancer at age 40 (Fig. 3h).

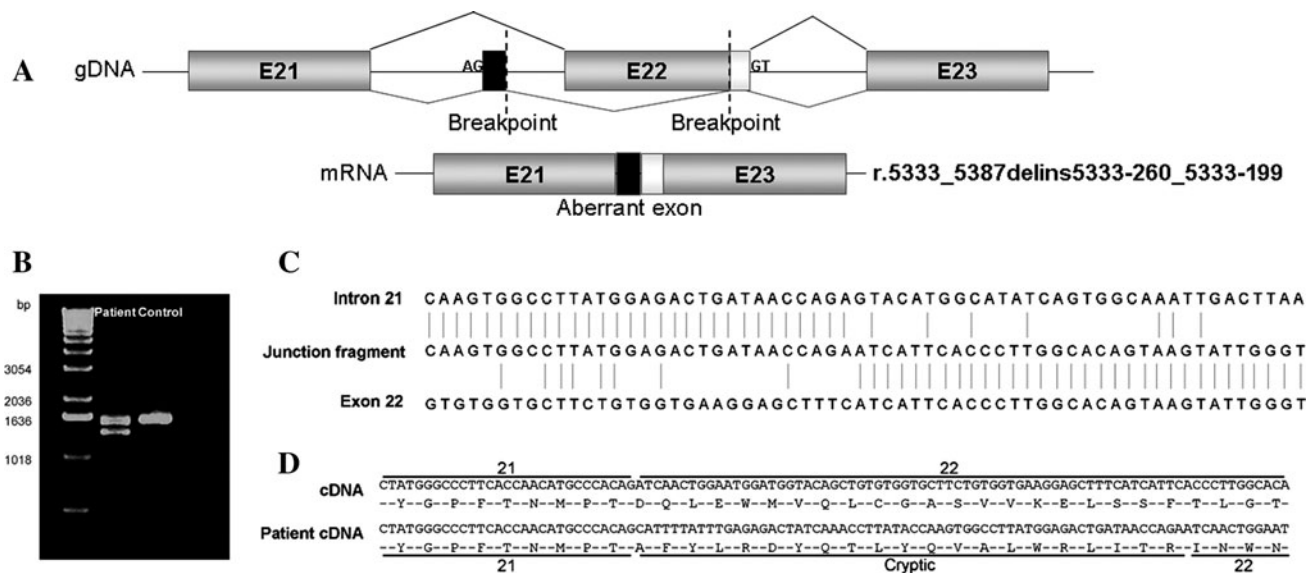

Fig. 7 Sequence analysis of a deletion-junction fragment and RT-PCR analysis of *BRCA1* mRNA from lymphocytes using primers located at exons 17 and 24 for a patient sample with a deletion of *BRCA1* exon 22. **a** scheme for aberrant splicing (*bottom lines*) caused by the deletion (*normal splicing shown by top lines*). **b** PCR detection of the deletion-

junction fragment in an agarose gel electrophoresis, showing the presence of a shorter band in the patient genomic DNA. **c** alignment of sequences of intron 21 (*top*), the deletion-junction fragment (*middle*) and exon 22 (*bottom*). **d** sequence showing the inclusion of an aberrant exon resulting in a frameshift (p.Asp1778AlafsX54)

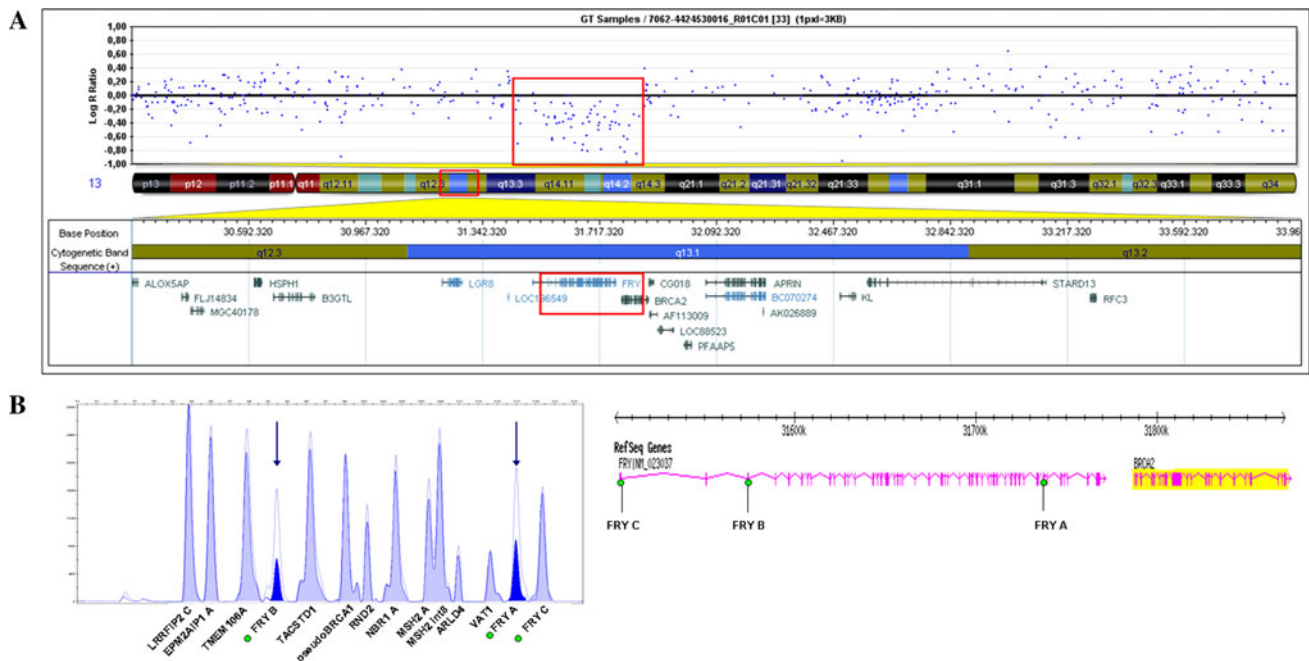

Fig. 8 Zoom-in SNP array (HumanCNV370-Quad v3 BeadChip from Illumina) and home-made MLPA results for a patient sample with a deletion of *BRCA2* exons 1–24. **a** logR ratios of array probes; deleted array probes are located inside the box. *Below*, a representation of the genes in and around the altered region. The results show a deletion of approximately 330 Kb, including the majority of the

FRY gene. **b left**, fluorescence MLPA profile obtained with our home-made probes from patient DNA (*shadow peaks*) superimposed on a normal control sample (note the ~50% reduction in the heights corresponding to two of the *FRY* gene probes); **right**, position of the home-made probes in the region

This rearrangement has been reported in two previous studies [18, 31]. Long-range PCR was performed to determine the breakpoint. PCR products from the patient examined by agarose gel electrophoresis yielded two bands: the wild-type band and the junction fragment product, which was approximately 2.5 kb smaller. Sequence analysis confirmed a deletion encompassing 2,463 bp, c.7436-270_7805+691del. Two interspersed elements in inverted orientation are embedded in this region: an AluSx in intron 14 and an AluJb in intron 16, with 160 bp sharing 83% homology. The deletion presented here is different to the one described by Casilli et al. [31]. RNA/cDNA analysis confirmed the skipping of exons 15 and 16 (r.7436_7805del), leading to a frameshift and a subsequent putative truncated protein (p.Asp2479GlyfsX46).

Discussion

In this study, we carried out MLPA analyses of 310 high-risk breast and/or ovarian cancer patients prior to an additional mutation screening analysis. MLPA detected six rearrangements in *BRCA1* and two in *BRCA2*. The proportion of pathogenic point mutations identified in this set of samples is of 17% (unpublished results). To the best of our knowledge, the clinical features of families carrying

the detected rearrangements were not different to those of families exhibiting other types of mutations. Many studies of large genomic rearrangements that cause predisposition to breast and/or ovarian cancer and other genetic disorders have identified breakpoints embedded within highly similar duplicated sequences, such as Alu repeat elements. These findings have led to the recognition of the role of meiotic non-allelic homologous recombination in the genesis of many of these large rearrangements. Consequently, rearrangements of this type are thought to be more common in *BRCA1*, since the *BRCA1* sequence is composed of approximately 42% Alu sequences, whereas *BRCA2* contains few Alu repeats [32]. In our samples, we found Alu elements to be involved at least in two of the eight alterations detected. Another example is the deletion of exons 1–2 of *BRCA1*, which is the most frequent rearrangement reported in this gene. The deletion seems to arise due to the presence of a *BRCA1* pseudogene with a high percentage of sequence identity for these two exons that would eventually predispose to aberrant recombination events such as those observed between Alu elements.

The deletion breakpoints were characterized in three of our cases. In two of these, a recombination event was found to be located within Alu repeats; of these two cases, in one the breakpoints were in direct orientation and in the other they were in inverted orientation. In the third case, sequence

Fig. 9 a MLPA fragment analysis of *BRCA2* gene. Each peak represents MLPA probes, identified by a specific fragment size (x-axis: fragment size; y-axis: fluorescence intensity). Electropherograms of a normal reference sample (*top*) and a sample from a patient carrying a deletion (*bottom*). Note the decrease in height of exons 15 and 16 in the patient electropherogram (*pointed by arrows*) compared to the normal control sample. **b** RT-PCR analysis of *BRCA2* mRNA from lymphocytes using primers spanning exons 11–17. Del370 denotes a fragment containing a 370-bp deletion corresponding to the absence of exons 15 and 16 which is shown in the patient sample but not in the control RT-PCR products

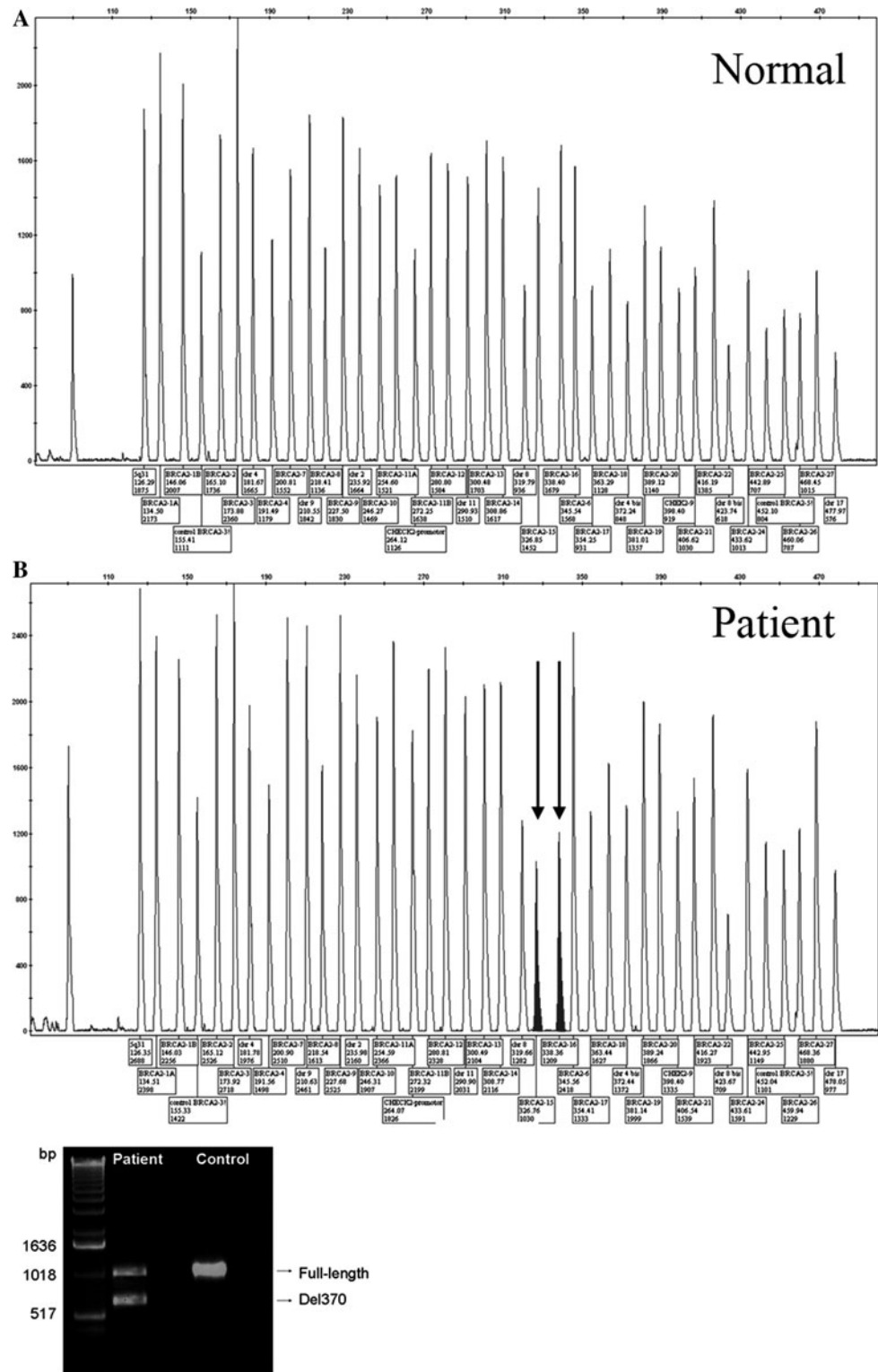

analysis of the region surrounding the breakpoints did not show homology to any Alu element or any recombination-associated motifs that may have been involved in the rearrangement process, which is indicative of a non-homologous mechanism such as non-homologous end joining, an alternative process by which DNA double-strand

breaks are repaired. This process is likely to play a significant role in generating structural variations [5].

Although a lower proportion of large rearrangements was observed in *BRCA2* than in *BRCA1*, which is consistent with the findings of previous studies, we would still recommend MLPA analysis of this gene in the screening of

high-risk breast and/or ovarian cancer families. This would make it possible to identify almost every mutation in these high-penetrance genes and to produce a more comprehensive picture of the mutational spectrum in patients with HBOC, which is particularly relevant in families with cases of male breast cancer, where rearrangements in *BRCA2* appear to be much more frequent. Approximately 50% of the reported *BRCA2* rearrangements have been found in families with cases of male breast cancer [10, 18, 33, 34].

Six of the detected rearrangements are deletions. Deletion of the first exon would probably affect the production and/or stability of the transcript, which would be the case of the first three rearrangements identified in our population (deletion of exons 1–2 and exons 1–13 in *BRCA1* and deletion of exons 1–24 in *BRCA2*). In the remaining cases, the rearrangement creates either a premature stop codon that would eventually produce putative truncated proteins (as in the cases of *BRCA1* exon 22 deletion and *BRCA2* exon 15–16 deletion) or an in-frame deletion affecting important functional domains of the proteins (as in the case of mutation *BRCA1* exon 16–23 deletion). Two of the rearrangements consist of duplications, and in these cases it is extremely difficult to ascertain the clinical significance. Unfortunately, for the two cases presented here we have not enough familial samples to perform a complete cosegregation analysis. In both the cases, we were unable to amplify the duplicated segment by PCR to characterize the mutation in detail at the nucleotide level. In the case of the *BRCA1* duplication of exons 1–2, we also attempted to study the effect of the duplication at the RNA level, but we were unable to amplify an aberrant allele. For the patient with the *BRCA1* duplication of exons 9–24, we identified co-occurrence with a clear pathogenic mutation in exon 2 of the *BRCA1* gene, although we were unable to determine whether the same allele is affected in both cases. It should be stressed that, in general terms, it is difficult to assess the pathogenic role of large duplications without performing functional or comprehensive cosegregation or population-based studies. We believe that duplications should be treated with caution when considered in genetic counseling, since they are often directly classified as pathogenic variants without further analysis, and it cannot be ruled out that the duplicated segment coexists close to the wild-type gene without affecting its normal expression.

Our findings confirm that, like in other populations, large genomic rearrangements in the *BRCA1/BRCA2* genes are also responsible for familial breast and ovarian cancers in the Spanish population. In fact, large rearrangements represent 14.5% of the total number of pathogenic mutations characterized in this set of patients; even if we exclude the two identified duplications and consider them as unknown significant variants, pathogenic mutations identified by MLPA account for 10.9% of all disease-causing mutations

in the *BRCA1/BRCA2* genes in our population. These results highlight the importance of performing this type of screening when studying HBOC families.

In conclusion, our strategy, which combines a comprehensive set of methodologies such as FISH analysis, long-range PCR, SNP arrays, and home-made MLPA probes, has been shown to be a powerful tool for confirming identified rearrangements and for determining their size in either direction outside the genes, which facilitates accurate breakpoint characterization.

Acknowledgments We thank all patients and relatives who participated in this study. We also thank the Fundació Roses Contra el Càncer for financial support. Contract grant sponsor: Spanish Health Research Fund; Carlos III Health Institute; Spanish Ministry of Education and Science; Catalan Health Institute; and the Autonomous Government of Catalonia. Contract grant numbers: SAF2006-05399; ISCIIIRETIC: RD06/0020/0028, RD06/0020/1020, RD06/0020/1050, RD06/0020/1051, and 2009SGR290.

References

1. Miki Y, Swensen J, Shattuck-Eidens D et al (1994) A strong candidate for the breast and ovarian cancer susceptibility gene *BRCA1*. *Science* 266:66–71
2. Wooster R, Bignell G, Lancaster J et al (1995) Identification of the breast cancer susceptibility gene *BRCA2*. *Nature* 378:789–792
3. Easton DP, Peto J (1990) The contribution of inherited predisposition to cancer incidence. *Cancer Surv* 9:395–416
4. Claus EB, Schildkraut JM, Thompson WD et al (1996) The genetic attributable risk of breast and ovarian cancer. *Cancer* 77: 2318–2324
5. Hastings PJ, Lupski JR, Rosenberg SM et al (2009) Mechanisms of change in gene copy number. *Nat Rev Genet* 10:551–564
6. Schouten JP, McElgunn CJ, Waaijer R et al (2002) Relative quantification of 40 nucleic acid sequences by multiplex ligation-dependent probe amplification. *Nucleic Acids Res* 30:e57
7. Engert S, Wappenschmidt B, Betz B et al (2008) MLPA screening in the *BRCA1* gene from 1, 506 German hereditary breast cancer cases: novel deletions, frequent involvement of exon 17, and occurrence in single early-onset cases. *Hum Mutat* 29:948–958
8. Walsh T, Casadei S, Coats KH et al (2006) Spectrum of mutations in *BRCA1*, *BRCA2*, *CHEK2*, and *TP53* in families at high risk of breast cancer. *JAMA* 295:1379–1388
9. Mazoyer S (2005) Genomic rearrangements in the *BRCA1* and *BRCA2* genes. *Hum Mutat* 25:415–422
10. Tournier I, Paillerets BB, Sobol H et al (2004) Significant contribution of germline *BRCA2* rearrangements in male breast cancer families. *Cancer Res* 64:8143–8147
11. Montagna M, Dalla Palma M, Menin C et al (2003) Genomic rearrangements account for more than one-third of the *BRCA1* mutations in northern Italian breast/ovarian cancer families. *Hum Mol Genet* 12:1055–1061
12. Hogervorst FB, Nederlof PM, Gille JJ et al (2003) Large genomic deletions and duplications in the *BRCA1* gene identified by a novel quantitative method. *Cancer Res* 63:1449–1453
13. Moisan AM, Fortin J, Dumont M et al (2006) No evidence of *BRCA1/2* genomic rearrangements in high-risk French-Canadian breast/ovarian cancer families. *Genet Test* 10:104–115

14. Lim YK, Lau PT, Ali AB et al (2007) Identification of novel BRCA large genomic rearrangements in Singapore Asian breast and ovarian patients with cancer. *Clin Genet* 71:331–342
15. Miramar MD, Calvo MT, Rodriguez A et al (2008) Genetic analysis of BRCA1 and BRCA2 in breast/ovarian cancer families from Aragon (Spain): two novel truncating mutations and a large genomic deletion in BRCA1. *Breast Cancer Res Treat* 112:353–358
16. de la Hoya M, Gutierrez-Enriquez S, Velasco E et al (2006) Genomic rearrangements at the BRCA1 locus in Spanish families with breast/ovarian cancer. *Clin Chem* 52:1480–1485
17. Palanca Suela S, Esteban Cardenosa E, Barragan Gonzalez E et al (2008) Identification of a novel BRCA1 large genomic rearrangement in a Spanish breast/ovarian cancer family. *Breast Cancer Res Treat* 112:63–67
18. Gutierrez-Enriquez S, de la Hoya M, Martinez-Bouzas C et al (2007) Screening for large rearrangements of the BRCA2 gene in Spanish families with breast/ovarian cancer. *Breast Cancer Res Treat* 103:103–107
19. Peiffer DA, Le JM, Steemers FJ et al (2006) High-resolution genomic profiling of chromosomal aberrations using infinium whole-genome genotyping. *Genome Res* 16:1136–1148
20. Unger MA, Nathanson KL, Calzone K et al (2000) Screening for genomic rearrangements in families with breast and ovarian cancer identifies BRCA1 mutations previously missed by conformation-sensitive gel electrophoresis or sequencing. *Am J Hum Genet* 67:841–850
21. Puget N, Gad S, Perrin-Vidoz L et al (2002) Distinct BRCA1 rearrangements involving the BRCA1 pseudogene suggest the existence of a recombination hot spot. *Am J Hum Genet* 70:858–865
22. Brown MA, Lo LJ, Catteau A et al (2002) Germline BRCA1 promoter deletions in UK and Australian familial breast cancer patients: identification of a novel deletion consistent with BRCA1: psiBRCA1 recombination. *Hum Mutat* 19:435–442
23. Hartmann C, John AL, Klaes R et al (2004) Large BRCA1 gene deletions are found in 3% of German high-risk breast cancer families. *Hum Mutat* 24:534
24. Preisler-Adams S, Schonbuchner I, Fiebig B et al (2006) Gross rearrangements in BRCA1 but not BRCA2 play a notable role in predisposition to breast and ovarian cancer in high-risk families of German origin. *Cancer Genet Cytogenet* 168:44–49
25. Agata S, Viel A, Della Puppa L et al (2006) Prevalence of BRCA1 genomic rearrangements in a large cohort of Italian breast and breast/ovarian cancer families without detectable BRCA1 and BRCA2 point mutations. *Genes Chromosom Cancer* 45:791–797
26. Veschi S, Aceto G, Scioletti AP et al (2007) High prevalence of BRCA1 deletions in BRCA1-positive patients with high carrier probability. *Ann Oncol* 18 (Suppl 6):vi86–92
27. Palma MD, Domchek SM, Stopfer J et al (2008) The relative contribution of point mutations and genomic rearrangements in BRCA1 and BRCA2 in high-risk breast cancer families. *Cancer Res* 68:7006–7014
28. Ratajska M, Brozek I, Senkus-Konefka E et al (2008) BRCA1 and BRCA2 point mutations and large rearrangements in breast and ovarian cancer families in Northern Poland. *Oncol Rep* 19:263–268
29. Pylkas K, Erkkö H, Nikkila J et al (2008) Analysis of large deletions in BRCA1, BRCA2 and PALB2 genes in Finnish breast and ovarian cancer families. *BMC Cancer* 8:146
30. Petrij-Bosch A, Peelen T, van Vliet M et al (1997) BRCA1 genomic deletions are major founder mutations in Dutch breast cancer patients. *Nat Genet* 17:341–345
31. Casilli F, Tournier I, Sinilnikova OM et al (2006) The contribution of germline rearrangements to the spectrum of BRCA2 mutations. *J Med Genet* 43:e49
32. Hansen TO, Jonson L, Albrechtsen A et al (2009) Large BRCA1 and BRCA2 genomic rearrangements in Danish high risk breast-ovarian cancer families. *Breast Cancer Res Treat* 115:315–323
33. Karhu R, Laurila E, Kallioniemi A et al (2006) Large genomic BRCA2 rearrangements and male breast cancer. *Cancer Detect Prev* 30:530–534
34. Woodward AM, Davis TA, Silva AG et al (2005) Large genomic rearrangements of both BRCA2 and BRCA1 are a feature of the inherited breast/ovarian cancer phenotype in selected families. *J Med Genet* 42:e31