



**HAL**  
open science

# A second gradient material resulting from the homogenization of an heterogeneous linear elastic medium

Catherine Pideri, Pierre Seppecher

► **To cite this version:**

Catherine Pideri, Pierre Seppecher. A second gradient material resulting from the homogenization of an heterogeneous linear elastic medium. *Continuum Mechanics and Thermodynamics*, 1997, 9 (5), pp.241-257. hal-00527291

**HAL Id: hal-00527291**

**<https://hal.science/hal-00527291v1>**

Submitted on 18 Oct 2010

**HAL** is a multi-disciplinary open access archive for the deposit and dissemination of scientific research documents, whether they are published or not. The documents may come from teaching and research institutions in France or abroad, or from public or private research centers.

L'archive ouverte pluridisciplinaire **HAL**, est destinée au dépôt et à la diffusion de documents scientifiques de niveau recherche, publiés ou non, émanant des établissements d'enseignement et de recherche français ou étrangers, des laboratoires publics ou privés.

# **A second gradient material resulting from the homogenization of an heterogeneous linear elastic medium**

**C. Pideri and P. Seppecher**

Laboratoire d'Analyse Non Linéaire Appliquée, Université de Toulon et du Var, BP 132 - 83957 La Garde Cedex, France

Homogenization may change fundamentally the constitutive laws of materials. We show how a heterogeneous Cauchy continuum may lead to a non Cauchy continuum. We study the effective properties of a linear elastic medium reinforced periodically with thin parallel fibers made up of a much stronger linear elastic medium and we prove that, when the Lamé coefficients in the fibers and the radius of the fibers have appropriate order of magnitude, the effective material is a second gradient material, i.e. a material whose energy depends on the second gradient of the displacement.

## **1 Introduction**

Continuum mechanics is usually understood as a homogenized description of materials which are heterogeneous at the microscopic level. Then, it is natural to expect from any general theory of continuum mechanics to be stable by homogenization procedures. We prove in this paper that the class of Cauchy continua does not enjoy this stability property. Indeed, we show that the effective properties of some periodic elastic material have to be described by a second gradient theory.

We consider a composite material made up of an elastic matrix reinforced with elastic fibers. Both materials are isotropic linear elastic materials, the Lamé coefficients in the fibers being larger than in the matrix. The structure is periodic: we assume that the fibers are parallel cylinders with the circular section arranged along a square lattice (see Fig. 1).

Homogenization procedure consists in studying the limit behaviour of the material when the period of the structure tends to zero. What is the behaviour of the other physical quantities as the period tends to zero? The effective properties of the material strongly depend on them: when the elasticity coefficients in the fibers are of the same order of magnitude as in the matrix and when the radius of the fibers is of the same order of magnitude as the period, the problem is a classic one in homogenization theory: the effective material is still a linear elastic material whose coefficients can be expressed in terms of the geometry and of the elasticity coefficients of the matrix and the fibers [18]. We study a different case: we want to describe a composite medium reinforced by very thin and very rigid fibers. Then, it is natural to assume that the radius of the fibers tends to zero faster than the period and that the elasticity coefficients in the fibers tend to infinity.

Let us now fix some notations: by convention, we choose the characteristic length of the domain as the unit length. The period of the lattice is denoted by  $\varepsilon$ . We study the limit  $\varepsilon \rightarrow 0$  and every quantity which is not assumed to be constant as  $\varepsilon$  tends to zero, is indexed by  $\varepsilon$ . For instance, the radius of the fibers is denoted by  $r_\varepsilon$ , the Lamé coefficients in the fibers are denoted by  $\lambda_\varepsilon$  and  $\mu_\varepsilon$  while the Lamé coefficients in the matrix are denoted by  $\lambda_0$  and  $\mu_0$ . Then our assumptions read

$$\frac{r_\varepsilon}{\varepsilon} \rightarrow 0 \quad , \quad \lambda_\varepsilon \rightarrow \infty \quad , \quad \mu_\varepsilon \rightarrow \infty \quad .$$

This situation has already been studied by D. Caillerie [7] who, setting  $\lambda_\varepsilon = (r_\varepsilon/\varepsilon)^{-\theta}$ ,  $\mu_\varepsilon = (r_\varepsilon/\varepsilon)^{-\theta}$ , considered in two cases the limit  $(\varepsilon, r_\varepsilon/\varepsilon) \rightarrow (0, 0)$ : ( $r_\varepsilon/\varepsilon \rightarrow 0$  then  $\varepsilon \rightarrow 0$ ) and ( $\varepsilon \rightarrow 0$  then  $r_\varepsilon/\varepsilon \rightarrow 0$ ). He found that both cases lead to an elastic material but that the homogenized elasticity coefficients depend on the limit procedure: the two limits  $\varepsilon \rightarrow 0$  and  $(r_\varepsilon/\varepsilon) \rightarrow 0$  do not commute. Here we let  $\frac{r_\varepsilon}{\varepsilon}$ ,  $\mu_\varepsilon^{-1}$  and  $\lambda_\varepsilon^{-1}$  tend to zero together and assume that:

$$\lim_{\varepsilon \rightarrow 0} \frac{r_\varepsilon}{\varepsilon} = 0, \quad \lim_{\varepsilon \rightarrow 0} \varepsilon^2 \log(r_\varepsilon) = 0, \quad \lim_{\varepsilon \rightarrow 0} \frac{\mu_\varepsilon r_\varepsilon^4}{\varepsilon^2} = \mu_1 > 0, \quad \lim_{\varepsilon \rightarrow 0} \frac{\lambda_\varepsilon}{\mu_\varepsilon} = \ell.$$

This particular scaling leads to a very different limit behaviour. We prove that the energy of the effective material depends not only on the strain tensor (as a classical elastic material) but also on the second gradient of the displacement. This result has been announced in [17].

Materials whose energy depends on the second gradient of the displacement cannot be considered as Cauchy continua otherwise one would be led to a thermodynamic paradox [12]. This paradox can be removed by extending the thermodynamical framework [12] but the fundamental point is that the Cauchy stress tensor is not sufficient to describe internal forces [20]. External forces concentrate along any edge of the boundary and the Cauchy theorem defining the Cauchy stress tensor cannot be applied [10, 11]. Moreover, a supplementary boundary condition is needed to write well-posed problems, which is unusual and not intuitive [19]. The simplest way to describe these media is to use the second gradient theory [13, 14] or to consider them as Cosserat media [8]. Our result gives a new example of such a material together with a ‘‘microscopic’’ interpretation of its special features.

We emphasize that, going to the limit, the differential order of the energy changes (as does the system of partial differential equations associated with equilibrium). Such a change is not usual in homogenization theory. It arises in rod or plate theories [1] but seems then to be connected with a change of dimension. Our result shows that this is not necessary. Notice also that such a change in the differential order of the energy can not arise when considering scalar problems (like thermal conductivity problems). Indeed, consider a sequence of energies which are quadratic functions of the gradient of a scalar quantity  $u$ ; these energies decrease when truncating  $u$  and this property is preserved when going to the limit. Then, a representation theorem for Dirichlet forms [6, 5] assures that the limit energy can be represented as the sum of a term depending on  $u$  and  $\nabla u$  and a non-local term of the form:  $\int \int_{\Omega \times \Omega} K(x, y)(u(x) - u(y))^2 dx dy$ . In other words, we can expect non-local effects but no increase of the differential order. Our result shows that this argument cannot be extended to elasticity problems.

Non-local effects actually arise for some scalar singular perturbation problems [5, 4] and we should probably have obtained non-local effects if assuming that  $\varepsilon^2 |\log(r_\varepsilon)|$  converges to a finite positive value instead of zero. We do not have non-local effects under our assumptions: the second gradient part of the limit energy cannot be interpreted, as it is often done, as the limit of non-local interactions whose range is very short.

Our study is variational. We identify the  $\Gamma$ -limit  $E_0$  of the energy  $E_\varepsilon$  of our composite material. The notion of  $\Gamma$ -convergence corresponds to the intuitive notion of convergence of models: the result is obtained without considering external forces, it remains valid in presence of body forces (for definition and properties of  $\Gamma$ -convergence, refer to [9]).

The limit energy is made explicit in Sect. 2 where we state precisely our result. Section 3 is devoted to the more difficult part of the proof: considering a sequence of displacement fields  $(u_\varepsilon)$  converging to some  $u$ , we have to express the lower bound for the energy  $E_\varepsilon(u_\varepsilon)$  in terms of  $u$ . This needs an accurate description of the asymptotic behaviour of  $u_\varepsilon$ . Especially  $u_\varepsilon$  has to be described at the scale  $r_\varepsilon$  inside the fibers: we need a multiscale notion of convergence. However, we do not expect any periodicity with period  $r_\varepsilon$ ; the classical notions of multiscale convergence (as defined in [16] or [2]) are not convenient. In Subsect. 3.1, we develop an adapted notion of double-scale convergence which describes the asymptotic behaviour of  $u_\varepsilon$  in the fibers, that is in a set of scale  $r_\varepsilon$  but with periodicity  $\varepsilon$ . Section 4 is devoted to the end the proof: for any admissible displacement field  $u$  we have to construct an approximating sequence  $u_\varepsilon$  whose limit energy is not larger than  $E_0(u)$ . Such an approximation is obtained by choosing  $u_\varepsilon = u$  in the main part of the matrix, a rod-like displacement field in the fibers and a suitable interpolation in transition layers around each fiber.

## 2 The main result

### 2.1 Notations and Geometry

In  $\mathbb{R}^3$  we refer to a point  $x$  by its Cartesian coordinates  $(x_1, x_2, x_3)$ . In the same way the coordinates of any vector  $u$  are denoted by  $(u_1, u_2, u_3)$ . The symmetric part of the gradient of  $u$  (the strain tensor) is denoted by  $e(u) := (\nabla u + \nabla u^t)/2$ . This tensor belongs to the set of 3-3 symmetric matrices which we denote by  $\mathcal{M}$ . The trace of a matrix  $A$  is denoted by  $\text{Tr}(A)$ .

We use the summation convention, but, as we consider two and three dimensional spaces, we adopt the following convention: a repeated Latin index is summed from 1 to 3 while a Greek index is summed from 1 to 2.

For every Borel set  $D$  and  $u \in L^1(D)$ , we denote by  $|D|$  the Lebesgue measure of  $D$  and by  $\int_D u dx$  the mean value of  $u$  on  $D$ :  $\int_D u dx := |D|^{-1} \int_D u dx$ .

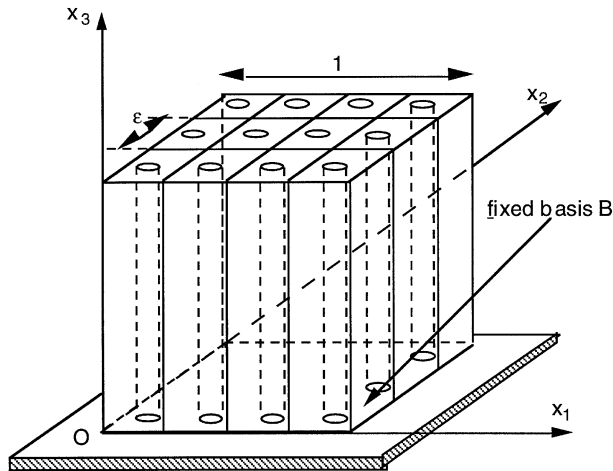

Fig. 1. The composite material,  $\Omega$

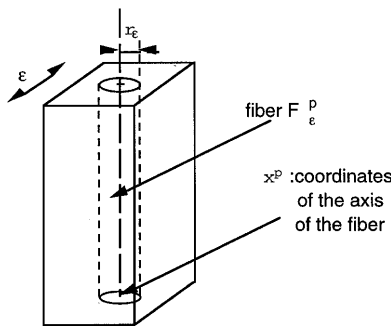

Fig. 2. A period  $P_\epsilon^p$  of the composite material

In order to describe the periodic structure of our composite material, we introduce two positive real parameters  $\epsilon$  and  $r_\epsilon$  ( $r_\epsilon \leq \epsilon$ ). Then we define the projection  $p_\epsilon$ :

$$p_\epsilon : \quad \mathbb{R}^2 \longrightarrow \mathbb{R}^2$$

$$(x_1, x_2) \longmapsto \left( \epsilon \left( E\left(\frac{x_1}{\epsilon}\right) + \frac{1}{2} \right), \epsilon \left( E\left(\frac{x_2}{\epsilon}\right) + \frac{1}{2} \right) \right),$$

where  $E(t)$  denotes the integer part of a real  $t$  and we define the periodic function  $y^\epsilon$  by

$$y_\epsilon : \quad \mathbb{R}^3 \longrightarrow \mathbb{R}^2$$

$$(x_1, x_2, x_3) \longmapsto r_\epsilon^{-1} [(x_1, x_2) - p_\epsilon(x_1, x_2)].$$

Next, we define the sets  $F_\varepsilon$  and  $M_\varepsilon$ , referred to as “the fibers” and “the matrix” respectively, by:

$$F_\varepsilon := \{x \in \mathbb{R}^3 : |y_\varepsilon(x)| < 1\} \quad , \quad M_\varepsilon := \mathbb{R}^3 \setminus F_\varepsilon \quad (1)$$

We assume that the composite material lies in the cube  $\Omega = (0, 1)^3$  and we denote by  $\mathcal{B}$  its “lower” face:  $\mathcal{B} = (0, 1)^2 \times \{0\}$ . On  $\Omega$  the projection  $p_\varepsilon$  ranges onto a finite set of points which we denote by  $\left\{x^p; p \in \mathcal{P}_\varepsilon := \left\{1 \dots \frac{1}{\varepsilon^2}\right\}\right\}$ . The domain  $\Omega$  is the union of the  $\varepsilon^{-2}$  parallelepipeds  $P_\varepsilon^p := \{x \in \Omega : p_\varepsilon(x) = x^p\}$  which correspond to the periods of  $y_\varepsilon$ .

The fiber contained in the period  $P_\varepsilon^p$  (a circular cylinder of radius  $r_\varepsilon$ , see Fig. 2) is denoted by  $F_\varepsilon^p := F_\varepsilon \cap P_\varepsilon^p$ . The total volume of the fibers contained in  $\Omega$  is  $|F_\varepsilon \cap \Omega| = \sum_{p \in \mathcal{P}_\varepsilon} |F_\varepsilon^p| = \pi r_\varepsilon^2 \varepsilon^{-2}$ .

## 2.2 Elastic energy

We assume that  $F_\varepsilon$  and  $M_\varepsilon$  consist of two different isotropic elastic materials: we define for every Borel set  $D$  the matrix energy by

$$E^m(D, u) := \int_D \left[ \frac{\lambda_0}{2} (\text{Tr}(e(u)))^2 + \mu_0 e(u)^2 \right] dx \quad , \quad (2)$$

where  $(\lambda_0, \mu_0)$  denote the (positive) elasticity Lamé coefficients in the matrix. In the same way, we define the fiber energy by

$$E_\varepsilon^f(D, u) := \int_D \left[ \frac{\lambda_\varepsilon}{2} (\text{Tr}(e(u)))^2 + \mu_\varepsilon e(u)^2 \right] dx \quad , \quad (3)$$

where  $(\lambda_\varepsilon, \mu_\varepsilon)$  denote the (positive) elasticity Lamé coefficients in the fibers.

We assume perfect adhesion between the matrix and the fibers. Moreover, we assume that both materials are fixed to the plane  $\{x_3 = 0\}$ . Then, for any displacement  $u \in L^2(\Omega, \mathbb{R}^3)$ , we define the total energy  $E_\varepsilon(u) := E_\varepsilon(\Omega, u)$  of our composite material by

$$E_\varepsilon(\Omega, u) := \begin{cases} E^m(M_\varepsilon \cap \Omega, u) + E_\varepsilon^f(F_\varepsilon \cap \Omega, u), & \text{if } u \in H^1(\Omega, \mathbb{R}^3) \\ & \text{and } u = 0 \text{ on } \mathcal{B} \text{ ,} \\ +\infty & \text{otherwise .} \end{cases} \quad (4)$$

## 2.3 Order of magnitude of the different parameters

In order to study the  $\Gamma$ -limit of  $E_\varepsilon$  as  $\varepsilon$  tends to zero, we must specify our assumptions upon the behaviour of  $r_\varepsilon$ ,  $\lambda_\varepsilon$  and  $\mu_\varepsilon$  as  $\varepsilon$  tends to zero: we assume that  $r_\varepsilon$  obeys the limit relations

$$\lim_{\varepsilon \rightarrow 0} \frac{r_\varepsilon}{\varepsilon} = 0 \quad , \quad (5)$$

$$\lim_{\varepsilon \rightarrow 0} \varepsilon^2 \log(r_\varepsilon) = 0 \quad (6)$$

and that  $\mu_\varepsilon$  and  $\lambda_\varepsilon$  fulfill the limit conditions

$$\lim_{\varepsilon \rightarrow 0} \frac{\mu_\varepsilon r_\varepsilon^4}{\varepsilon^2} = \mu_1 \in ]0, +\infty[ \quad , \quad (7)$$

$$\lim_{\varepsilon \rightarrow 0} \frac{\lambda_\varepsilon}{\mu_\varepsilon} = \ell \in [0, +\infty[ \quad . \quad (8)$$

Assumption (5) states that the fibers are much thinner than the period of the medium; it is one of our basic assumptions. However, they cannot be too thin, otherwise the connection between the displacement fields in the matrix and in the fibers disappears when  $\varepsilon$  tends to zero. This fact can be explained as follows: if the radius of the fibers is infinitely smaller than  $\varepsilon$ , the fibers behave like one-dimensional media and it is well

known that a one-dimensional medium has no connection with a three-dimensional elastic medium. We will see later that restriction (6) assures that the global displacement of each fiber coincides with the displacement of the matrix when  $\varepsilon$  tends to zero. Note that assumption (6) is not very restrictive: any power law  $r_\varepsilon = \varepsilon^\gamma$ ,  $\gamma > 1$  is admissible.

The energy of a bent rod is related to its curvature, that is to the second gradient of its displacement. As our goal is to obtain second gradient effects, we expect each fiber to behave like a rod. The bending stiffness of a unique fiber is  $\frac{\pi}{4} r_\varepsilon^4 \mu_\varepsilon \frac{3\lambda_\varepsilon + 2\mu_\varepsilon}{\lambda_\varepsilon + \mu_\varepsilon}$  (refer to any textbook for mechanics of structures or to the pioneering work of St. Venant [3]). Assumptions (7) and (8) state that this stiffness is of the order of  $\varepsilon^2$ , the inverse of the number ( $\varepsilon^{-2}$ ) of fibers.

#### 2.4 The main result

Our result states that  $E_\varepsilon$   $\Gamma$ -converges in  $L^2(\Omega, \mathbb{R}^3)$  to  $E_0$  defined by:

$$E_0(u) = \begin{cases} E^m(\Omega, u) + \int_\Omega \frac{k}{2} \left[ \left( \frac{\partial^2 u_1}{\partial x_3^2} \right)^2 + \left( \frac{\partial^2 u_2}{\partial x_3^2} \right)^2 \right] dx, & \\ \text{if } u \in H^1(\Omega, \mathbb{R}^3), \frac{\partial^2 u}{\partial x_3^2} \in L^2(\Omega, \mathbb{R}^3), & \\ u_3 = 0 \text{ a.e. in } \Omega, u = \frac{\partial u}{\partial x_3} = 0 \text{ a.e. on } \mathcal{B}, & \\ +\infty & \text{otherwise.} \end{cases} \quad (9)$$

where

$$k = \frac{\pi}{4} \frac{3\ell + 2}{\ell + 1} \mu_1, \quad (10)$$

More precisely we have the following:

**Theorem 1.** *i) Let  $u_\varepsilon$  be a sequence such that  $E_\varepsilon(u_\varepsilon)$  is bounded. Then  $u_\varepsilon$  is strongly relatively compact in  $L^2(\Omega, \mathbb{R}^3)$ .*

*ii) Moreover, for any sequence  $u_\varepsilon$  converging to  $u$  in  $L^2(\Omega, \mathbb{R}^3)$ , the following lower bound inequality holds:*

$$\liminf_{\varepsilon \rightarrow 0} E_\varepsilon(u_\varepsilon) \geq E_0(u). \quad (11)$$

*iii) Conversely, for every  $u$  in  $L^2(\Omega, \mathbb{R}^3)$ , there exists an approximating sequence  $u_\varepsilon$  in  $L^2(\Omega, \mathbb{R}^3)$  such that*

$$u_\varepsilon \rightarrow u \text{ in } L^2(\Omega, \mathbb{R}^3), \quad \limsup_{\varepsilon \rightarrow 0} E_\varepsilon(u_\varepsilon) \leq E_0(u). \quad (12)$$

*Proof of assertion (i):* It is clear from assumptions (5), (7) and (8) that  $\lambda_\varepsilon$  and  $\mu_\varepsilon$  tend to infinity. Then there exists a positive real  $c$  such that  $E_\varepsilon(u) \geq c \int_\Omega e(u)^2 dx$  for every  $u$  in  $H^1(\Omega, \mathbb{R}^3)$ . Due to Korn's inequality, there exists a positive real  $C$  such that  $E_\varepsilon(u) \geq C \|u\|_{H^1(\Omega, \mathbb{R}^3)}^2$ . The sequence  $u_\varepsilon$  is then bounded in  $H^1(\Omega, \mathbb{R}^3)$ : it is strongly relatively compact in  $L^2(\Omega, \mathbb{R}^3)$ .  $\square$

The proofs of (ii) and (iii) are less straightforward. They are given in the following two sections.

### 3 Proof of the lower bound inequality

#### 3.1 Preliminaries, double-scale convergence

Let us denote by  $D_1$  the unit disk of  $\mathbb{R}^2$  and by  $\mathcal{D}$  the set of functions  $\mathcal{D} := C_c^\infty(\Omega \times D_1, \mathbb{R})$ . We associate to the sequence of sets  $(F_\varepsilon \cap \Omega)$  the following "double scale" convergence:

**Definition:** We say that a sequence  $u_\varepsilon$  in  $L^2(\Omega, \mathbb{R})$  double scale converges to  $v \in L^2(\Omega \times D_1, \mathbb{R})$  and we write  $u_\varepsilon \rightharpoonup v$  if and only if

$$\forall \varphi \in \mathcal{D}, \quad \int_{F_\varepsilon \cap \Omega} u_\varepsilon(x) \varphi(x, y_\varepsilon(x)) dx \rightarrow \int_{\Omega} \int_{D_1} v(x, y) \varphi(x, y) dy dx . \quad (13)$$

This definition is extended to vector field or tensor field sequences: we say that such sequences d.s.-converge if and only if every component is d.s.-convergent.

**Remark 1.** For every function  $\Phi \in \mathcal{D}$ ,

$$u_\varepsilon \rightharpoonup v \implies \Phi(\cdot, y_\varepsilon(\cdot)) u_\varepsilon(\cdot) \rightharpoonup \Phi v . \quad (14)$$

Indeed, for every  $\psi \in \mathcal{D}$ , the product  $\psi \Phi$  belongs to  $\mathcal{D}$  and the result is obtained by applying the definition of the d.s.-convergence of  $u_\varepsilon$  with  $\varphi = \psi \Phi$ .

**Lemma 1.** For every function  $\Phi \in \mathcal{D}$  we have

$$\Phi(\cdot, y_\varepsilon(\cdot)) \rightharpoonup \Phi . \quad (15)$$

*Proof:* For  $\varphi \in \mathcal{D}$ , let us compute the limit of  $\int_{F_\varepsilon \cap \Omega} \varphi(x, y_\varepsilon(x)) dx$ . Using the Fubini theorem and changing variables in each fiber we get

$$\begin{aligned} \int_{F_\varepsilon \cap \Omega} \varphi(x, y_\varepsilon(x)) dx &= \varepsilon^2 \sum_{p \in \mathcal{P}_\varepsilon} \int_{F_\varepsilon^p} \varphi(x, y_\varepsilon(x)) dx \\ &= |F_\varepsilon \cap \Omega|^{-1} r_\varepsilon^2 \sum_{p \in \mathcal{P}_\varepsilon} \int_0^1 \int_{D_1} \varphi((x_1^p + r_\varepsilon y_1, x_2^p + r_\varepsilon y_2, x_3), (y_1, y_2)) dy dx_3. \end{aligned}$$

As the function  $\varphi$  is uniformly continuous on  $\Omega \times D_1$ , we have the following uniform estimations:

$$|\varphi((x_1^p + r_\varepsilon y_1, x_2^p + r_\varepsilon y_2, x_3), (y_1, y_2)) - \varphi((x_1^p, x_2^p, x_3), (y_1, y_2))| = O(r_\varepsilon)$$

and

$$\left| \sum_{p \in \mathcal{P}_\varepsilon} \varphi((x_1^p, x_2^p, x_3), y) 1_{F_\varepsilon^p}(x) - \varphi(x, y) \right| = O(\varepsilon) ,$$

which implies

$$\left| \int_0^1 \varepsilon^2 \sum_{p \in \mathcal{P}_\varepsilon} \varphi((x_1^p, x_2^p, x_3), y) dx_3 - \int_{\Omega} \varphi(x, y) dx \right| = O(\varepsilon).$$

Hence

$$\begin{aligned} \lim_{\varepsilon \rightarrow 0} \int_{F_\varepsilon \cap \Omega} \varphi(x, y_\varepsilon(x)) dx &= \lim_{\varepsilon \rightarrow 0} |F_\varepsilon \cap \Omega|^{-1} r_\varepsilon^2 \varepsilon^{-2} \int_{\Omega} \int_{D_1} \varphi(x, y) dy dx \\ &= \int_{\Omega} \int_{D_1} \varphi(x, y) dy dx . \end{aligned}$$

In other words, the constant function 1 d.s.-converges to itself. The lemma is proved by recalling Remark 1.  $\square$

**Lemma 2.** Let  $u_\varepsilon$  be a sequence in  $L^2(\Omega, \mathbb{R})$  such that  $\int_{F_\varepsilon \cap \Omega} u_\varepsilon^2(x) dx$  is bounded, then there exists a subsequence of  $u_\varepsilon$  (still denoted by  $u_\varepsilon$ ) and a function  $v \in L^2(\Omega \times D_1, \mathbb{R})$  such that

$$u_\varepsilon \rightharpoonup v$$

*Proof:* Assume  $\int_{F_\varepsilon \cap \Omega} u_\varepsilon^2(x) dx \leq M$  and consider the sequence of measures  $\nu_\varepsilon$  on  $\Omega \times D_1$  defined by

$$\nu_\varepsilon := |F_\varepsilon \cap \Omega|^{-1} u_\varepsilon(x) \delta_{y_\varepsilon(x)}(dy) dx. \quad (16)$$

Since the sequence  $\nu_\varepsilon(\Omega \times D_1)$  is bounded, there exists a measure  $\nu$  such that  $\nu_\varepsilon \rightharpoonup \nu$  for some subsequence. Moreover, for every  $\varphi \in \mathcal{S}$ , we have

$$\begin{aligned} \int_{\Omega \times D_1} \varphi(x, y) d\nu_\varepsilon &= |F_\varepsilon \cap \Omega|^{-1} \int_{F_\varepsilon \cap \Omega} \varphi(x, y_\varepsilon(x)) u_\varepsilon(x) dx \\ &\leq \left( \int_{F_\varepsilon \cap \Omega} (u_\varepsilon(x))^2 dx \right)^{1/2} \left( \int_{F_\varepsilon \cap \Omega} (\varphi(x, y_\varepsilon(x)))^2 dx \right)^{1/2} \\ &\leq M^{1/2} \left( \int_{F_\varepsilon \cap \Omega} \varphi(x, y_\varepsilon(x))^2 dx \right)^{1/2}. \end{aligned}$$

As  $\varphi^2 \in \mathcal{S}$ , using Lemma 1, we have

$$\begin{aligned} \limsup_{\varepsilon \rightarrow 0} \int_{\Omega \times D_1} \varphi(x, y) d\nu_\varepsilon &\leq M^{1/2} \left( \int_{\Omega} \int_{D_1} (\varphi(x, y))^2 dy dx \right)^{1/2} \\ \int_{\Omega \times D_1} \varphi(x, y) d\nu &\leq M^{1/2} \pi^{-1/2} \|\varphi\|_{L^2(\Omega \times D_1)}. \end{aligned}$$

The measure  $\nu$ , as a linear functional, is bounded on the unit ball of  $L^2(\Omega \times D_1, \mathbb{R})$ : there exists a function  $v \in L^2(\Omega \times D_1, \mathbb{R})$  such that  $\nu = v dx dy$ . The convergence of the sequence of measures  $\nu_\varepsilon$  to the measure  $v dx dy$  is clearly equivalent to the d.s.-convergence of  $u_\varepsilon$  to  $v$ .  $\square$

Let us notice that Lemma 2 can obviously be extended to vector or matrix fields.

**Lemma 3.** *Let  $u_\varepsilon$  be a bounded sequence in  $H^1(\Omega, \mathbb{R}^3)$ . Then, there exists a constant  $C$  such that, for  $\varepsilon$  small enough,*

$$\int_{F_\varepsilon \cap \Omega} (u_\varepsilon(x))^2 dx \leq C \left( \|u_\varepsilon\|_{L^2(\Omega, \mathbb{R}^3)} - \varepsilon^2 \log(r_\varepsilon) \right). \quad (17)$$

*Proof:* Assume that  $\|u_\varepsilon\|_{H^1(\Omega, \mathbb{R}^3)}^2 \leq M$ . Then

$$\sum_{p \in \mathcal{P}_\varepsilon} \int_{P_\varepsilon^p} (\nabla u_\varepsilon)^2 dx \leq M.$$

In each period  $P_\varepsilon^p$ , we use the cylindrical coordinates, defining  $u_\varepsilon^p$  by

$$u_\varepsilon^p(r, \theta, x_3) := u_\varepsilon(x_1^p + r \cos \theta, x_2^p + r \sin \theta, x_3). \quad (18)$$

Then, we have, for every  $\rho_1 \leq \rho_2 \leq \varepsilon/2$ ,

$$\sum_{p \in \mathcal{P}_\varepsilon} \int_0^1 \int_0^{2\pi} \int_{\rho_1}^{\rho_2} \left( \frac{\partial u_\varepsilon^p}{\partial r} \right)^2 r dr d\theta dx_3 \leq M.$$

A simple one-dimensional minimization shows that

$$\int_{\rho_1}^{\rho_2} \left( \frac{\partial u_\varepsilon^p}{\partial r} \right)^2 r dr \geq \frac{[u_\varepsilon^p(\rho_2) - u_\varepsilon^p(\rho_1)]^2}{\log(\rho_2) - \log(\rho_1)}.$$

Hence

$$\sum_{p \in \mathcal{P}_\varepsilon} \int_0^1 \int_0^{2\pi} [u_\varepsilon^p(\rho_2, \theta, x_3) - u_\varepsilon^p(\rho_1, \theta, x_3)]^2 d\theta dx_3 \leq M \log\left(\frac{\rho_2}{\rho_1}\right).$$

Let us denote by  $f$  the quantity



$$f(\rho) = \sum_{p \in \mathcal{P}_\varepsilon} \int_0^1 \int_0^{2\pi} (u_\varepsilon^p(\rho, \theta, x_3))^2 d\theta dx_3 . \quad (19)$$

The last inequality implies that, for every  $\rho_1 \leq \rho_2 \leq \varepsilon/2$ ,

$$f(\rho_1) \leq 2f(\rho_2) + 2M \log\left(\frac{\rho_2}{\rho_1}\right) .$$

As the ratio  $r_\varepsilon/\varepsilon$  tends to zero, we may assume, without loss of generality, that  $r_\varepsilon \leq \varepsilon/4$ . Then, for every  $\rho_2 \in [\varepsilon/4, \varepsilon/2]$ , we can bound the mean value of  $u_\varepsilon^2$  on  $F_\varepsilon \cap \Omega$  by

$$\begin{aligned} \int_{F_\varepsilon \cap \Omega} u_\varepsilon^2 dx &= |F_\varepsilon \cap \Omega|^{-1} \int_0^{r_\varepsilon} f(r) r dr \\ &\leq |F_\varepsilon \cap \Omega|^{-1} \int_0^{r_\varepsilon} \left(2r f(\rho_2) + 2Mr \log\left(\frac{\rho_2}{r}\right)\right) dr \\ &\leq \frac{\varepsilon^2}{\pi r_\varepsilon^2} \left(f(\rho_2) r_\varepsilon^2 + Mr_\varepsilon^2 \left(\log\left(\frac{\rho_2}{r_\varepsilon}\right) + \frac{1}{2}\right)\right) \\ &\leq \frac{1}{\pi} \left(4\varepsilon \rho_2 f(\rho_2) + M \varepsilon^2 \left(\log\left(\frac{\varepsilon}{r_\varepsilon}\right) + \frac{1}{2}\right)\right) \end{aligned}$$

and, taking the mean value of this last term for  $\rho_2 \in [\varepsilon/4, \varepsilon/2]$ , we get

$$\begin{aligned} \int_{F_\varepsilon \cap \Omega} u_\varepsilon^2 dx &\leq \frac{1}{\pi} \left(16 \int_{\frac{\varepsilon}{4}}^{\frac{\varepsilon}{2}} f(r) r dr + M \varepsilon^2 (\log(\varepsilon) - \log(r_\varepsilon) + \frac{1}{2})\right) \\ &\leq \frac{1}{\pi} \left(16 \|u_\varepsilon\|_{L^2(\Omega, \mathbb{R}^3)}^2 + M \varepsilon^2 (\log(\varepsilon) - \log(r_\varepsilon) + \frac{1}{2})\right) . \end{aligned}$$

For  $\varepsilon$  sufficiently small,  $|\log(\varepsilon) + 1/2| \leq |\log(r_\varepsilon)|$ . The lemma is proved by taking  $C = \sup\{16/\pi, 2M/\pi\}$ .  $\square$

**Lemma 4.** *Let  $u_\varepsilon$  be a bounded sequence in  $H^1(\Omega, \mathbb{R}^3)$ . Then*

- i)  $\int_{F_\varepsilon \cap \Omega} u_\varepsilon^2 dx$  is bounded.
- ii) If  $u_\varepsilon \rightarrow u$  in  $L^2(\Omega, \mathbb{R}^3)$ , then  $\int_{F_\varepsilon \cap \Omega} (u_\varepsilon(x) - u(x))^2 dx \rightarrow 0$ .
- iii) If  $u_\varepsilon \rightarrow u$  in  $L^2(\Omega, \mathbb{R}^3)$  and  $u_\varepsilon \rightharpoonup v$ , then

$$u(x) = \int_{D_1} v(x, y) dy , \quad a.e. \text{ in } \Omega. \quad (20)$$

*Proof:* Assertion (i) is a trivial consequence of Lemma 3 and assumption (6). Here it becomes clear how assumption (6) connects the displacement in the fibers to the displacement in the matrix. Note that, at this point, the boundedness of  $\varepsilon^2 \log(r_\varepsilon)$  should be sufficient.

Assertion (ii) needs the convergence  $\varepsilon^2 \log(r_\varepsilon) \rightarrow 0$ . Then one simply must apply Lemma 3 to the sequence  $(u_\varepsilon - u)$ .

To prove assertion (iii), let us consider for any  $\nu > 0$ , a field  $\Phi_\nu \in C_c^\infty(\Omega, \mathbb{R}^3)$  such that  $\|\Phi_\nu - u\|_{L^2(\Omega, \mathbb{R}^3)} < \nu$ . For any  $\varphi \in C_c^\infty(\Omega, \mathbb{R}^3)$  we have

$$\begin{aligned} & \left| \lim_{\varepsilon \rightarrow 0} \int_{F_\varepsilon \cap \Omega} (u_\varepsilon(x) - \Phi_\nu(x)) \varphi(x) dx \right| \\ & \leq \lim_{\varepsilon \rightarrow 0} \left( \int_{F_\varepsilon \cap \Omega} |u_\varepsilon(x) - \Phi_\nu(x)|^2 dx \right)^{1/2} \lim_{\varepsilon \rightarrow 0} \left( \int_{F_\varepsilon \cap \Omega} \varphi(x)^2 dx \right)^{1/2} . \end{aligned}$$

Applying Lemma 3 to the sequence  $|u_\varepsilon - \Phi_\nu|$  shows that this last term is bounded by the norm  $\|u_\varepsilon(x) - \Phi_\nu(x)\|_{L^2(\Omega, \mathbb{R}^3)}$  and therefore is of order  $O(\nu)$ . Now, passing to the double scale limit, using the definition of  $v$  and Lemma 1, we get

$$\left| \int_{\Omega} \left( \int_{D_1} v(x, y) dy - \Phi_\nu(x) \right) \varphi(x) dx \right| \leq O(\nu) .$$

Assertion (iii) is proved by recalling that this inequality is valid for every  $\nu$ .  $\square$

### 3.2 Limits of a sequence with bounded energy

**Lemma 5.** *Let  $u_\varepsilon$  be a sequence of  $L^2(\Omega, \mathbb{R}^3)$  with bounded energy. Then, up to a subsequence (still denoted by  $u_\varepsilon$ ), there exist  $v \in L^2(\Omega \times D_1, \mathbb{R}^3)$ ,  $w \in L^2(\Omega \times D_1, \mathbb{R})$  and  $\chi \in L^2(\Omega \times D_1, \mathcal{M})$  such that*

$$u_\varepsilon \rightharpoonup v , \quad \frac{u_{\varepsilon 3}}{r_\varepsilon} \rightharpoonup w , \quad \frac{e(u_\varepsilon)}{r_\varepsilon} \rightharpoonup \chi . \quad (21)$$

*Proof:* Assume  $E_\varepsilon(u_\varepsilon) < M$ , then the sequence  $u_\varepsilon$  is bounded in  $H^1(\Omega, \mathbb{R}^3)$ , Lemma 4 states that the sequence  $\int_{F_\varepsilon \cap \Omega} u_\varepsilon^2 dx$  is bounded and Lemma 2 implies the existence of  $v \in L^2(\Omega \times D_1, \mathbb{R}^3)$  such that  $u_\varepsilon \rightharpoonup v$ . On the other hand, as  $\mu_\varepsilon \int_{F_\varepsilon \cap \Omega} e(u_\varepsilon)^2 dx < M$ , we have

$$\frac{\mu_\varepsilon r_\varepsilon^4}{\varepsilon^2} \pi \int_{F_\varepsilon \cap \Omega} \left( \frac{1}{r_\varepsilon} \frac{\partial u_{\varepsilon 3}}{\partial x_3} \right)^2 dx < M .$$

As any sequence with bounded energy satisfies  $u_{\varepsilon 3}(x_1, x_2, 0) = 0$  a.e. on  $\mathcal{B}$ , a simple one-dimensional minimization shows that

$$\int_0^1 \left( \frac{\partial u_{\varepsilon 3}}{\partial x_3} \right)^2 dx_3 \geq \frac{\pi^2}{4} \int_0^1 (u_{\varepsilon 3})^2 dx_3, \quad \text{for a.e. } (x_1, x_2).$$

Hence,

$$\frac{\mu_\varepsilon r_\varepsilon^4}{\varepsilon^2} \pi \int_{F_\varepsilon \cap \Omega} \left( \frac{u_{\varepsilon 3}}{r_\varepsilon} \right)^2 dx \leq \frac{4}{\pi^3} M .$$

As  $\mu_\varepsilon r_\varepsilon^4 / \varepsilon^2 \rightarrow \mu_1$ , the sequence  $\int_{F_\varepsilon \cap \Omega} \left( \frac{u_{\varepsilon 3}}{r_\varepsilon} \right)^2 dx$  is bounded: the sequence  $u_{\varepsilon 3} / r_\varepsilon$  satisfies the assumptions of Lemma 2; the existence of  $w$  is assured.

In the same way, from inequality  $\mu_\varepsilon \int_{F_\varepsilon \cap \Omega} e(u_\varepsilon)^2 dx < M$ , we deduce

$$\frac{\mu_\varepsilon r_\varepsilon^4}{\varepsilon^2} \pi \int_{F_\varepsilon \cap \Omega} \left( \frac{e(u_\varepsilon)}{r_\varepsilon} \right)^2 dx < M .$$

The sequence  $e(u_\varepsilon) / r_\varepsilon$  verifies the assumptions of Lemma 2: the existence of  $\chi$  is assured.  $\square$

**Lemma 6.** *Consider a sequence  $u_\varepsilon$  with bounded energy and converging to some  $u$  in  $L^2(\Omega, \mathbb{R}^3)$ , then*

$$u \in H^1(\Omega, \mathbb{R}^3), \quad \frac{\partial^2 u_1}{\partial x_3^2} \in L^2(\Omega, \mathbb{R}^3), \quad \frac{\partial^2 u_2}{\partial x_3^2} \in L^2(\Omega, \mathbb{R}^3), \quad u_3(x) = 0 \text{ a.e. in } \Omega .$$

Moreover, there exists a subsequence (still denoted by  $u_\varepsilon$ ) and  $q \in L^2(\Omega, \mathbb{R})$  such that

$$\left( \frac{e(u_\varepsilon)}{r_\varepsilon} \right)_{33} \rightharpoonup q(x) - \frac{\partial^2 u_1}{\partial x_3^2}(x) y_1 - \frac{\partial^2 u_2}{\partial x_3^2}(x) y_2 . \quad (22)$$

*Proof:* First, let us notice that the sequence  $u_\varepsilon$  is bounded in  $H^1(\Omega, \mathbb{R}^3)$ . Then the limit  $u$  belongs to  $H^1(\Omega, \mathbb{R}^3)$ . Lemma 5 assures the existence of  $v \in L^2(\Omega \times D_1, \mathbb{R}^3)$ ,  $w \in L^2(\Omega \times D_1, \mathbb{R})$  and  $\chi \in L^2(\Omega \times D_1, \mathcal{M})$  such that, up to a subsequence,

$$u_\varepsilon \rightharpoonup v, \quad \frac{u_{\varepsilon 3}}{r_\varepsilon} \rightharpoonup w \quad \text{and} \quad \frac{e(u_\varepsilon)}{r_\varepsilon} \rightharpoonup \chi.$$

The convergence  $u_{\varepsilon 3}/r_\varepsilon \rightharpoonup w$  immediately yields  $u_{\varepsilon 3} \rightharpoonup 0$ , i.e.  $v_3 = 0$ . Using the relation  $u(x) = \int_{D_1} v(x, y) dy$  stated in Lemma 4, we get the identity  $u_3 = 0$  a.e. in  $\Omega$ .

Consider now a tensor field  $\varphi \in C_c^\infty(\Omega \times D_1, \mathcal{M})$ . We have, using the definition of  $\chi$  and the divergence theorem,

$$\begin{aligned} \int_{\Omega} \int_{D_1} \chi_{ij}(x, y) \varphi_{ij}(x, y) dy dx &= \lim_{\varepsilon \rightarrow 0} \int_{F_\varepsilon \cap \Omega} \frac{1}{r_\varepsilon} e_{ij}(u_\varepsilon)(x) \varphi_{ij}(x, y_\varepsilon(x)) dx, \\ &= \lim_{\varepsilon \rightarrow 0} \int_{F_\varepsilon \cap \Omega} \frac{1}{r_\varepsilon} \frac{\partial u_{\varepsilon i}}{\partial x_j}(x) \varphi_{ij}(x, y_\varepsilon(x)) dx, \\ &= - \lim_{\varepsilon \rightarrow 0} \int_{F_\varepsilon \cap \Omega} \frac{1}{r_\varepsilon} u_{\varepsilon i}(x) \left[ \frac{\partial \varphi_{ij}}{\partial x_j}(x, y_\varepsilon(x)) + \frac{1}{r_\varepsilon} \frac{\partial \varphi_{i\alpha}}{\partial y_\alpha}(x, y_\varepsilon(x)) \right] dx, \\ &= - \lim_{\varepsilon \rightarrow 0} \left\{ \frac{1}{r_\varepsilon^2} \int_{F_\varepsilon \cap \Omega} u_{\varepsilon \beta}(x) \frac{\partial \varphi_{\beta\alpha}}{\partial y_\alpha}(x, y_\varepsilon(x)) dx \right. \\ &\quad \left. + \frac{1}{r_\varepsilon} \int_{F_\varepsilon \cap \Omega} \left( u_{\varepsilon \beta}(x) \frac{\partial \varphi_{\beta j}}{\partial x_j}(x, y_\varepsilon(x)) + \frac{u_{\varepsilon 3}(x)}{r_\varepsilon} \frac{\partial \varphi_{3\alpha}}{\partial y_\alpha}(x, y_\varepsilon(x)) \right) dx \right. \\ &\quad \left. + \int_{F_\varepsilon \cap \Omega} \frac{u_{\varepsilon 3}(x)}{r_\varepsilon} \frac{\partial \varphi_{3j}}{\partial x_j}(x, y_\varepsilon(x)) dx \right\}. \end{aligned} \quad (23)$$

Multiplying equation (23) by  $r_\varepsilon^2$  and passing to the limit  $\varepsilon \rightarrow 0$  gives

$$\begin{aligned} \lim_{\varepsilon \rightarrow 0} \int_{F_\varepsilon \cap \Omega} u_{\varepsilon \beta}(x) \frac{\partial \varphi_{\beta\alpha}}{\partial y_\alpha}(x, y_\varepsilon(x)) dx &= 0, \\ \int_{\Omega} \int_{D_1} v_\beta(x, y) \frac{\partial \varphi_{\beta\alpha}}{\partial y_\alpha}(x, y) dy dx &= 0, \\ \left\langle \frac{\partial v_\beta}{\partial y_\alpha} \varphi_{\beta\alpha} \right\rangle &= 0, \end{aligned} \quad (24)$$

where  $\langle \rangle$  denotes the distribution bracket on  $\Omega \times D_1$ . This last equation, valid for any field  $\varphi$  of a symmetric plane matrix and whose support is included in  $\Omega \times D_1$ , is equivalent to the antisymmetry (in the sense of distributions)

$$\frac{\partial v_1}{\partial y_2} = -\frac{\partial v_2}{\partial y_1}, \quad \frac{\partial v_1}{\partial y_1} = \frac{\partial v_2}{\partial y_2} = 0.$$

Then (refer for instance to [15]) there exist three functions  $c_1, c_2$  and  $t$  in  $L^2(\Omega, \mathbb{R})$  such that

$$v_1(x, y) = c_1(x) - t(x)y_2, \quad v_2(x, y) = c_2(x) + t(x)y_1.$$

Lemma 4 implies  $c_1 = u_1$  and  $c_2 = u_2$ . Hence

$$v_1(x, y) = u_1(x) - t(x)y_2, \quad v_2(x, y) = u_2(x) + t(x)y_1. \quad (25)$$

Now, consider the fields  $\varphi$  such that  $\varphi_{\beta\alpha} = 0, \forall \alpha, \beta \in \{1, 2\}$ . Multiplying equation (23) by  $r_\varepsilon$  and passing to the limit gives

$$\begin{aligned}
\lim_{\varepsilon \rightarrow 0} \int_{F_\varepsilon \cap \Omega} \left[ u_{\varepsilon 3}(x) \frac{\partial \varphi_{\beta 3}}{\partial x_3}(x, y_\varepsilon(x)) + \frac{u_{\varepsilon 3}(x)}{r_\varepsilon} \frac{\partial \varphi_{3\alpha}}{\partial y_\alpha}(x, y_\varepsilon(x)) \right] dx &= 0, \\
\int_{\Omega} \int_{D_1} \left[ v_\beta(x, y) \frac{\partial \varphi_{\beta 3}}{\partial x_3}(x, y) + w(x, y) \frac{\partial \varphi_{3\alpha}}{\partial y_\alpha}(x, y) \right] dy dx &= 0, \\
\left\langle \frac{\partial v_\beta}{\partial x_3} \varphi_{\beta 3} \right\rangle + \left\langle \frac{\partial w}{\partial y_\alpha} \varphi_{3\alpha} \right\rangle &= 0, \\
\left\langle \left( \frac{\partial v_\alpha}{\partial x_3} + \frac{\partial w}{\partial y_\alpha} \right) \varphi_{3\alpha} \right\rangle &= 0.
\end{aligned} \tag{26}$$

This last equation, valid for every functions  $\varphi_{3\alpha}$  whose support is included in  $\Omega \times D_1$ , implies that, in the sense of distributions,

$$\frac{\partial v_\alpha}{\partial x_3} + \frac{\partial w}{\partial y_\alpha} = 0,$$

which, using (25), becomes

$$-\frac{\partial u_1}{\partial x_3} + \frac{\partial t}{\partial x_3} y_2 = \frac{\partial w}{\partial y_1}, \quad -\frac{\partial u_2}{\partial x_3} - \frac{\partial t}{\partial x_3} y_1 = \frac{\partial w}{\partial y_2}.$$

The Schwarz theorem implies that  $\partial t / \partial x_3 = 0$ ; then

$$-\frac{\partial u_1}{\partial x_3} = \frac{\partial w}{\partial y_1}, \quad -\frac{\partial u_2}{\partial x_3} = \frac{\partial w}{\partial y_2}.$$

Therefore there exists a function  $s$  in  $L^2(\Omega, \mathbb{R})$  such that

$$w(x, y) = -\frac{\partial u_\alpha}{\partial x_3} y_\alpha + s(x). \tag{27}$$

Finally, considering matrix fields  $\varphi$  with a unique non vanishing component  $\varphi_{33}$ , equation (23) leads to

$$\begin{aligned}
\int_{\Omega} \int_{D_1} \chi_{33}(x, y) \varphi_{33}(x, y) dx &= -\lim_{\varepsilon \rightarrow 0} \int_{F_\varepsilon \cap \Omega} \frac{u_{\varepsilon 3}(x)}{r_\varepsilon} \frac{\partial \varphi_{33}}{\partial x_3}(x, y_\varepsilon(x)) dx \\
&= -\int_{\Omega} \int_{D_1} w(x, y) \frac{\partial \varphi_{33}}{\partial x_3}(x, y) dy dx \\
\langle \chi_{33} \varphi_{33} \rangle &= \left\langle \frac{\partial w}{\partial x_3} \varphi_{33} \right\rangle.
\end{aligned} \tag{28}$$

Then  $\chi_{33} = \partial w / \partial x_3$  in the sense of distributions. As  $\chi$  belongs to  $L^2(\Omega \times D_1, \mathcal{M})$ ,  $\partial w / \partial x_3$  belongs to  $L^2(\Omega \times D_1, \mathbb{R})$ . This means, by using (27) that  $\partial^2 u_\alpha / \partial x_3^2 \in L^2(\Omega, \mathbb{R})$ ,  $q := \partial s / \partial x_3 \in L^2(\Omega, \mathbb{R})$  and

$$\chi_{33}(x, y) = -\frac{\partial^2 u_\alpha}{\partial x_3^2}(x) y_\alpha + q(x). \tag{29}$$

□

### 3.3 Lower bound for the energy

Let  $u_\varepsilon$  be a sequence with bounded energy converging to some  $u$  in  $L^2(\Omega, \mathbb{R}^3)$ . We can assume without loss of generality that  $E_\varepsilon(u_\varepsilon)$  converges to  $\liminf E_\varepsilon(u_\varepsilon)$ . Then assertion (ii) of Theorem 1 will be proved if we prove that for some subsequence (still denoted by  $u_\varepsilon$ ) we have

$$\liminf_{\varepsilon \rightarrow 0} E_\varepsilon(u_\varepsilon) \geq E_0(u).$$

First, let us recall that the sequence  $u_\varepsilon$  is bounded in  $H^1(\Omega, \mathbb{R}^3)$ , then

$$u \in H^1(\Omega, \mathbb{R}^3) . \quad (30)$$

It is easy to get the lower bound for the energy outside the fibers: indeed, as  $E_\varepsilon(u_\varepsilon)$  is bounded,  $E_\varepsilon^f(F_\varepsilon \cap \Omega, u_\varepsilon)$  is also bounded. As the ratios  $\mu_0/\mu_\varepsilon$  and  $\lambda_0/\lambda_\varepsilon$  tend to zero, then  $E^m(F_\varepsilon \cap \Omega, u_\varepsilon)$  tends to 0. Hence

$$\liminf_{\varepsilon \rightarrow 0} E^m(M_\varepsilon \cap \Omega, u_\varepsilon) = \liminf_{\varepsilon \rightarrow 0} E^m(\Omega, u_\varepsilon) \geq E^m(\Omega, u) . \quad (31)$$

To estimate the energy in the fibers we use the lemmas stated in the preceeding subsections. Indeed we have

$$\begin{aligned} & \liminf_{\varepsilon \rightarrow 0} E_\varepsilon^f(F_\varepsilon \cap \Omega, u_\varepsilon) \\ &= \liminf_{\varepsilon \rightarrow 0} \left\{ \frac{\mu_\varepsilon r_\varepsilon^4}{\varepsilon^2} \pi \int_{F_\varepsilon \cap \Omega} \left( \frac{e(u_\varepsilon)}{r_\varepsilon} \right)^2 + \frac{\lambda_\varepsilon}{\mu_\varepsilon} \left( \frac{\text{Tr}(e(u_\varepsilon))}{r_\varepsilon} \right)^2 dx \right\} \\ &\geq \pi \mu_1 \liminf_{\varepsilon \rightarrow 0} \int_{F_\varepsilon \cap \Omega} \left[ \left( \frac{e(u_\varepsilon)}{r_\varepsilon} \right)^2 + \frac{\ell}{2} \left( \frac{\text{Tr}(e(u_\varepsilon))}{r_\varepsilon} \right)^2 \right] dx . \end{aligned} \quad (32)$$

From Lemma 5, we know that, possibly passing to a subsequence,  $e(u_\varepsilon)/r_\varepsilon$  admits a double scale limit  $\chi$ . As we cannot pass to the limit directly in inequality (32), we write its dual form

$$\begin{aligned} \liminf_{\varepsilon \rightarrow 0} E_\varepsilon^f(F_\varepsilon \cap \Omega, u_\varepsilon) &\geq \sup_{\varphi} \left\{ \pi \mu_1 \liminf_{\varepsilon \rightarrow 0} \int_{F_\varepsilon \cap \Omega} \left[ \frac{e(u_\varepsilon(x))}{r_\varepsilon} : \varphi(x, y_\varepsilon(x)) - \right. \right. \\ &\quad \left. \left. \frac{1}{4} \varphi(x, y_\varepsilon(x))^2 + \frac{\ell}{4(2+3\ell)} (\text{Tr}(\varphi(x, y_\varepsilon(x))))^2 \right] dx \right\} , \end{aligned}$$

where the supremum is taken for every  $\varphi \in C_c^\infty(\Omega \times D_1, \mathcal{M})$ . Then Remark 1 and Lemma 1 allow to pass to the limit

$$\begin{aligned} \liminf_{\varepsilon \rightarrow 0} E_\varepsilon^f(F_\varepsilon \cap \Omega, u_\varepsilon) &\geq \sup_{\varphi} \left\{ \pi \mu_1 \int_{\Omega} \int_{D_1} [\chi(x, y) : \varphi(x, y) - \right. \\ &\quad \left. \frac{1}{4} (\varphi(x, y))^2 + \frac{\ell}{4(2+3\ell)} (\text{Tr}(\varphi(x, y)))^2] dy dx \right\} . \end{aligned}$$

As  $C_c^\infty(\Omega \times D_1, \mathcal{M})$  is dense in  $L^2(\Omega \times D_1, \mathcal{M})$ , we get

$$\liminf_{\varepsilon \rightarrow 0} E_\varepsilon^f(F_\varepsilon \cap \Omega, u_\varepsilon) \geq \pi \mu_1 \int_{\Omega} \int_{D_1} \left[ \chi^2(x, y) + \frac{\ell}{2} (\text{Tr}(\chi(x, y)))^2 \right] dy dx .$$

It is easy to verify that, for every  $M$  in  $\mathcal{M}$ ,

$$M^2 + \frac{\ell}{2} (\text{Tr}(M))^2 \geq \frac{3\ell+2}{2(\ell+1)} M_{33}^2 . \quad (33)$$

Hence,

$$\liminf_{\varepsilon \rightarrow 0} E_\varepsilon^f(F_\varepsilon \cap \Omega, u_\varepsilon) \geq \pi \mu_1 \frac{3\ell+2}{(\ell+1)} \int_{\Omega} \int_{D_1} \chi_{33}^2(x, y) dy dx . \quad (34)$$

From Lemma 6, we know that

$$\frac{\partial^2 u_\alpha}{\partial x_3^2} \in L^2(\Omega, \mathbb{R}) , \quad (35)$$

and we can express  $\chi_{33}$  in terms of these second derivatives of  $u$

$$\liminf_{\varepsilon \rightarrow 0} E_\varepsilon^f(F_\varepsilon \cap \Omega, u_\varepsilon) \geq \frac{\pi}{2} \mu_1 \frac{3\ell+2}{(\ell+1)} \int_{\Omega} \int_{D_1} \left( q(x) - \frac{\partial^2 u_\alpha}{\partial x_3^2}(x) y_\alpha \right)^2 dy dx .$$

For  $\alpha = 1$  or  $2$ , we have

$$\int_{D_1} y_\alpha dy = 0 , \quad \int_{D_1} y_\alpha^2 dy = \frac{1}{4} , \quad \text{and} \quad \int_{D_1} y_1 y_2 dy = 0 .$$

Then we may deduce that

$$\liminf_{\varepsilon \rightarrow 0} E_\varepsilon^f(F_\varepsilon \cap \Omega, u_\varepsilon) \geq \frac{\pi\mu_1(3\ell+2)}{8(\ell+1)} \int_\Omega \left[ 4q^2(x) + \left( \frac{\partial^2 u_1}{\partial x_3^2} \right)^2 + \left( \frac{\partial^2 u_2}{\partial x_3^2} \right)^2 \right] dx ,$$

which implies

$$\liminf_{\varepsilon \rightarrow 0} E_\varepsilon^f(F_\varepsilon \cap \Omega, u_\varepsilon) \geq \frac{k}{2} \int_\Omega \left[ \left( \frac{\partial^2 u_1}{\partial x_3^2} \right)^2 + \left( \frac{\partial^2 u_2}{\partial x_3^2} \right)^2 \right] dx , \quad (36)$$

where  $k$  is defined by (10).

In order to obtain the boundary conditions, let us consider the extended domain  $\tilde{\Omega} := (0, 1)^2 \times ]-1, 1[$  and the extensions  $\tilde{u}_\varepsilon$  and  $\tilde{u}$  of  $u_\varepsilon$  and  $u$  on  $\tilde{\Omega}$  defined by

$$\begin{aligned} \tilde{u}_\varepsilon &:= u_\varepsilon \text{ on } \Omega , & \tilde{u} &:= u \text{ on } \Omega , \\ \tilde{u}_\varepsilon &:= \tilde{u} := 0 \text{ on } \tilde{\Omega} \setminus \Omega . \end{aligned}$$

The sequence  $E_\varepsilon(\tilde{\Omega}, \tilde{u}_\varepsilon)$  is bounded and  $\tilde{u}_\varepsilon$  converges to  $\tilde{u}$  in  $L^2(\tilde{\Omega}, \mathbb{R}^3)$ ; thus the results of Lemma 6 can be applied:  $\tilde{u} \in H^1(\tilde{\Omega}, \mathbb{R}^3)$  and  $\partial^2 \tilde{u}_\alpha / \partial x_3^2 \in L^2(\tilde{\Omega}, \mathbb{R})$  which implies

$$u = 0 \text{ a.e. on } \mathcal{B} , \quad \frac{\partial u_1}{\partial x_3} = \frac{\partial u_2}{\partial x_3} = 0 \text{ a.e. on } \mathcal{B} . \quad (37)$$

Assertion (ii) of Theorem 1 is proved by recalling (30), (31), (35), (36), and (37).  $\square$

#### 4 Proof of the upper bound inequality

Let us denote by  $\mathcal{H}$  the functional space

$$\{u \in H^1(\Omega, \mathbb{R}^3), u_3 = 0 \text{ a.e. on } \Omega, \frac{\partial^2 u}{\partial x_3^2} \in L^2(\Omega, \mathbb{R}^3), u = \frac{\partial u}{\partial x_3} = 0 \text{ a.e. on } \mathcal{B}\},$$

which is endowed with the norm

$$\|u\|_{\mathcal{H}} := \|u\|_{H^1(\Omega, \mathbb{R}^3)} + \left\| \frac{\partial^2 u}{\partial x_3^2} \right\|_{L^2(\Omega, \mathbb{R}^3)} .$$

For any  $u \in L^2(\Omega, \mathbb{R}^3)$  such that  $E_0(u) < +\infty$ , i.e., for any  $u \in \mathcal{H}$ , we have to construct an approximating sequence  $u_\varepsilon$  in  $L^2(\Omega, \mathbb{R}^3)$  such that

$$u_\varepsilon \longrightarrow u \text{ in } L^2(\Omega, \mathbb{R}^3) \quad \text{and} \quad \limsup_{\varepsilon \rightarrow 0} E_\varepsilon(u_\varepsilon) \leq E_0(u).$$

It is easy to verify that

$$\tilde{\mathcal{H}} := \{u \in C^\infty(\Omega, \mathbb{R}^3), u = \frac{\partial u}{\partial x_3} = \frac{\partial^2 u}{\partial x_3^2} = 0 \text{ a.e. on } \mathcal{B}\}$$

is dense in  $\mathcal{H}$ . Then, we can restrict our study to a function  $u \in \tilde{\mathcal{H}}$ . As  $E_0$  is continuous on  $\mathcal{H}$ , the result can be generalized to  $\tilde{\mathcal{H}}$ .

Let us choose a sequence  $R_\varepsilon$  such that  $r_\varepsilon \ll R_\varepsilon \ll \varepsilon$ , and let us divide  $M_\varepsilon$  in two parts by introducing a transition layer  $C_\varepsilon$

$$C_\varepsilon := \{x \in \Omega : 1 < |y_\varepsilon(x)| < r_\varepsilon^{-1} R_\varepsilon\}, \quad B_\varepsilon := \{x \in \Omega : |y_\varepsilon(x)| > r_\varepsilon^{-1} R_\varepsilon\},$$

The part of  $C_\varepsilon$  contained in a period  $P_\varepsilon^p$  is denoted by  $C_\varepsilon^p := C_\varepsilon \cap P_\varepsilon^p$

For every  $p$  in  $\mathcal{S}_\varepsilon$ , we define the function  $v_\varepsilon^p \in C^\infty((0, 1), \mathbb{R}^3)$  by

$$v_\varepsilon^p(x_3) := \int_{D_1} u(x_1^p + r_\varepsilon y_1, x_2^p + r_\varepsilon y_2, x_3) dy_1 dy_2 \quad (38)$$

and the function  $w_\varepsilon^p \in C^\infty((0, 1) \times \mathbb{R}^2, \mathbb{R}^3)$  by

$$\begin{aligned} w_{\varepsilon 1}^p(x_3, y) &:= v_{\varepsilon 1}^p(x_3) + r_\varepsilon^2 \frac{\ell}{2(\ell+1)} \left[ \frac{\partial^2 v_{\varepsilon 1}^p}{\partial x_3^2} \frac{y_1^2 - y_2^2}{2} + \frac{\partial^2 v_{\varepsilon 2}^p}{\partial x_3^2} y_1 y_2 \right], \\ w_{\varepsilon 2}^p(x_3, y) &:= v_{\varepsilon 2}^p(x_3) + r_\varepsilon^2 \frac{\ell}{2(\ell+1)} \left[ \frac{\partial^2 v_{\varepsilon 2}^p}{\partial x_3^2} \frac{y_2^2 - y_1^2}{2} + \frac{\partial^2 v_{\varepsilon 1}^p}{\partial x_3^2} y_1 y_2 \right], \\ w_{\varepsilon 3}^p(x_3, y) &:= -r_\varepsilon \frac{\partial v_{\varepsilon \alpha}^p}{\partial x_3} y_\alpha. \end{aligned} \quad (39)$$

The function  $w_\varepsilon^p$  may be interpreted as the rod-like displacement of the fiber  $F_\varepsilon^p$  whose global displacement is  $v_\varepsilon^p$  [3]. As  $u \in \mathcal{A}$ , we have  $u = \partial u / \partial x_3 = \partial^2 u / \partial x_3^2 = 0$  on  $\mathcal{B}$ . Therefore every function  $w_\varepsilon^p$  vanishes for  $x_3 = 0$ .

We define now the approximating sequence  $(u_\varepsilon)$  by setting

$$u_\varepsilon(x) := \begin{cases} u(x) & \text{on } B_\varepsilon, \\ w_\varepsilon^p(x_3, y_\varepsilon(x)) & \text{on each fiber } F_\varepsilon^p, \\ \begin{aligned} &\gamma(r) w_\varepsilon^p(x_3, (\cos \theta, \sin \theta)) \\ &+ (1 - \gamma(r)) u(x) \end{aligned} & \text{on each transition} \\ &\text{layer } C_\varepsilon^p, \end{cases} \quad (40)$$

where  $(r, \theta)$  denote the polar coordinates defined in each period  $P_\varepsilon^p$  by  $x_1 = x_1^p + r \cos \theta$ ,  $x_2 = x_2^p + r \sin \theta$  and  $\gamma$  is the function defined by

$$\gamma(r) := \frac{\log(r) - \log(R_\varepsilon)}{\log(r_\varepsilon) - \log(R_\varepsilon)}.$$

Notice that, by construction,  $u_\varepsilon$  belongs to  $H^1(\Omega, \mathbb{R}^3)$  and satisfies  $u_\varepsilon = 0$  on  $\mathcal{B}$ . Then

$$E_\varepsilon(u_\varepsilon) = E^m(B_\varepsilon \cap \Omega, u_\varepsilon) + E^m(C_\varepsilon \cap \Omega, u_\varepsilon) + E_\varepsilon^f(F_\varepsilon \cap \Omega, u_\varepsilon). \quad (41)$$

Moreover,  $u_\varepsilon$  tends to  $u$  in  $L^2(\Omega, \mathbb{R}^3)$ : indeed  $u_\varepsilon$  coincides with  $u$  on  $B_\varepsilon$ ,  $|\Omega \setminus B_\varepsilon| \rightarrow 0$ , and  $(u_\varepsilon)$  is uniformly bounded on  $F_\varepsilon$  and  $C_\varepsilon$ .

#### 4.1 Estimation for the energy of $u_\varepsilon$ in the matrix

As  $u_\varepsilon(x) := u(x)$  on  $B_\varepsilon$ , we have  $E^m(B_\varepsilon, u_\varepsilon) = E^m(B_\varepsilon, u)$ . As  $R_\varepsilon/\varepsilon \rightarrow 0$  one has  $|\Omega \setminus B_\varepsilon| \rightarrow 0$ . Moreover,  $u \in H^1(\Omega)$ , then  $E^m(\Omega \setminus B_\varepsilon, u) \rightarrow 0$  and

$$\lim_{\varepsilon \rightarrow 0} E^m(B_\varepsilon, u_\varepsilon) = E^m(\Omega, u). \quad (42)$$

#### 4.2 Estimation for the energy of $u_\varepsilon$ in the fibers

Let us estimate the energy of  $u_\varepsilon$  in each fiber  $F_\varepsilon^p$ : As  $u_\varepsilon(x) = w_\varepsilon^p(x, y_\varepsilon(x))$  in  $F_\varepsilon^p$ , we have

$$\begin{aligned} e_{11}(u_\varepsilon) &= e_{22}(u_\varepsilon) = r_\varepsilon \frac{\ell}{2(\ell+1)} \frac{\partial^2 v_{\varepsilon \alpha}^p}{\partial x_3^2} y_\alpha, \\ e_{33}(u_\varepsilon) &= -r_\varepsilon \frac{\partial^2 v_{\varepsilon \alpha}^p}{\partial x_3^2} y_\alpha, \\ e_{12}(u_\varepsilon) &= e_{21}(u_\varepsilon) = 0, \\ e_{13}(u_\varepsilon) &= e_{31}(u_\varepsilon) = r_\varepsilon^2 \frac{\ell}{4(\ell+1)} \left[ \frac{\partial^3 v_{\varepsilon 1}^p}{\partial x_3^3} \frac{y_1^2 - y_2^2}{2} + \frac{\partial^3 v_{\varepsilon 2}^p}{\partial x_3^3} y_1 y_2 \right], \\ e_{23}(u_\varepsilon) &= e_{32}(u_\varepsilon) = r_\varepsilon^2 \frac{\ell}{4(\ell+1)} \left[ \frac{\partial^3 v_{\varepsilon 2}^p}{\partial x_3^3} \frac{y_2^2 - y_1^2}{2} + \frac{\partial^3 v_{\varepsilon 1}^p}{\partial x_3^3} y_1 y_2 \right]. \end{aligned}$$

Hence

$$\begin{aligned} E_\varepsilon^f(F_\varepsilon^p, u_\varepsilon) &= r_\varepsilon^4 \int_0^1 \int_{D_1} \left[ \mu_\varepsilon \frac{3\ell^2 + 4\ell + 2}{2(\ell + 1)^2} + \lambda_\varepsilon \frac{1}{2(\ell + 1)^2} \right] \left[ \frac{\partial^2 v_{\varepsilon\alpha}^p}{\partial x_3^2} y_\alpha \right]^2 dx \\ &\quad + r_\varepsilon^6 \int_0^1 \int_{D_1} \left[ \mu_\varepsilon \frac{\ell^2}{8(\ell + 1)^2} \right] \left[ \left( \frac{\partial^3 v_{\varepsilon 1}^p}{\partial x_3^3} \right)^2 + \left( \frac{\partial^3 v_{\varepsilon 2}^p}{\partial x_3^3} \right)^2 \right] \left[ \frac{y_1^2 + y_2^2}{2} \right]^2 dx . \end{aligned}$$

Computing the integrals on  $D_1$  and summing for all sets  $F_\varepsilon^p$  we get

$$\begin{aligned} E_\varepsilon^f(F_\varepsilon \cap \Omega, u_\varepsilon) &= \sum_{p \in \mathcal{P}_\varepsilon} \left\{ \frac{\ell^2 \pi r_\varepsilon^6 \mu_\varepsilon}{96(\ell + 1)^2} \int_0^1 \left( \left( \frac{\partial^3 v_{\varepsilon 1}^p}{\partial x_3^3} \right)^2 + \left( \frac{\partial^3 v_{\varepsilon 2}^p}{\partial x_3^3} \right)^2 \right) dx_3 \right. \\ &\quad \left. + \frac{3\ell^2 + 4\ell + 2 + \frac{\lambda_\varepsilon}{\mu_\varepsilon}}{2(\ell + 1)^2} \frac{\pi r_\varepsilon^4 \mu_\varepsilon}{4} \int_0^1 \left( \left( \frac{\partial^2 v_{\varepsilon 1}^p}{\partial x_3^2} \right)^2 + \left( \frac{\partial^2 v_{\varepsilon 2}^p}{\partial x_3^2} \right)^2 \right) dx_3 \right\} . \end{aligned}$$

Passing to the limit  $\varepsilon \rightarrow 0$ , we have

$$\varepsilon^{-2} \frac{\ell^2}{8(\ell + 1)^2} \frac{\pi r_\varepsilon^6 \mu_\varepsilon}{12} \rightarrow 0, \quad \varepsilon^{-2} \frac{3\ell^2 + 4\ell + 2 + \frac{\lambda_\varepsilon}{\mu_\varepsilon}}{2(\ell + 1)^2} \frac{\pi r_\varepsilon^4 \mu_\varepsilon}{4} \rightarrow \frac{k}{2},$$

where  $k$  is defined by (10). Moreover, using the definition of the functions  $v_\varepsilon^p$ , we have

$$\begin{aligned} \varepsilon^2 \sum_{p \in \mathcal{P}_\varepsilon} \int_0^1 \left( \frac{\partial^2 v_{\varepsilon\alpha}^p}{\partial x_3^2} \right)^2 dx_3 &= \varepsilon^2 \int_{F_\varepsilon \cap \Omega} \left( \frac{\partial^2 u_\alpha}{\partial x_3^2} \right)^2 dx, \\ \varepsilon^2 \sum_{p \in \mathcal{P}_\varepsilon} \int_0^1 \left( \frac{\partial^3 v_{\varepsilon\alpha}^p}{\partial x_3^3} \right)^2 dx_3 &= \varepsilon^2 \int_{F_\varepsilon \cap \Omega} \left( \frac{\partial^3 u_\alpha}{\partial x_3^3} \right)^2 dx . \end{aligned}$$

Hence

$$\lim_{\varepsilon \rightarrow 0} E_\varepsilon^f(F_\varepsilon \cap \Omega, u_\varepsilon) = \frac{k}{2} \int_\Omega \left( \frac{\partial^2 u_1}{\partial x_3^2}^2 + \frac{\partial^2 u_2}{\partial x_3^2}^2 \right) dx . \quad (43)$$

#### 4.3 Estimation for the energy of $u_\varepsilon$ in the transition layer

Let  $M = \sup_\Omega \{ \sup(\nabla u, \nabla^2 u, \nabla^3 u) \}$ . We restrict attention to a cylinder  $C_\varepsilon^p$  and prove, in a first step, that  $|\nabla u_\varepsilon|$  is bounded on  $C_\varepsilon^p$ . We use the cylindrical coordinates  $(r, \theta, x_3)$  defined by  $x_1 = x_1^p + r \cos \theta$ ,  $x_2 = x_2^p + r \sin \theta$  (on  $C_\varepsilon^p$  we have  $r \in [r_\varepsilon, R_\varepsilon]$ ).

Clearly, in view of the definition of  $w_\varepsilon^p$ , there exists a positive real  $M_1$  such that

$$\left| \frac{\partial w_\varepsilon^p}{\partial \theta}(x_3, (\cos \theta, \sin \theta)) \right| \leq M_1 r_\varepsilon .$$

Moreover,  $\left| \frac{\partial u}{\partial \theta} \right| \leq Mr$  and whence

$$\begin{aligned} \left| \frac{1}{r} \frac{\partial u_\varepsilon}{\partial \theta} \right| &= \frac{1}{r} |(1 - \gamma(r)) \frac{\partial u}{\partial \theta}(x_1^p + r \cos \theta, x_2^p + r \sin \theta, x_3) + \\ &\quad \gamma(r) \frac{\partial w_\varepsilon^p}{\partial \theta}(x_3, (\cos \theta, \sin \theta))| \leq M_1 + M . \end{aligned} \quad (44)$$

On the other hand, owing to the definition of  $w_\varepsilon^p$ , there exists a positive real  $M_2$  such that, for every  $y \in D_1$  and  $x_3 \in [0, 1]$ ,  $|w_\varepsilon^p(x_3, y) - v_\varepsilon^p(x_3)| \leq M_2 r_\varepsilon$ . From the definition of  $v_\varepsilon^p$ , we have, for every  $r \geq r_\varepsilon$

$$|v_\varepsilon^p(x_3) - u(x_1^p + r \cos \theta, x_2^p + r \sin \theta, x_3)| \leq 2Mr .$$



Then, there exists a positive real  $M_3$  such that, for every  $r \geq r_\varepsilon$ ,  $y \in D_1$ ,  $\theta \in [0, 2\pi]$  and  $x_3 \in [0, 1]$ ,

$$|w_\varepsilon^p(x_3, y) - u(x_1^p + r \cos \theta, x_2^p + r \sin \theta, x_3)| \leq M_3 r .$$

Thus the following estimation for  $\partial u_\varepsilon / \partial r$  can be derived

$$\begin{aligned} & \left| \frac{\partial u_\varepsilon}{\partial r}(x_1^p + r \cos \theta, x_2^p + r \sin \theta, x_3) \right| \\ &= |(1 - \gamma(r)) \frac{\partial u}{\partial r}(x_1^p + r \cos \theta, x_2^p + r \sin \theta, x_3) \\ & \quad + \frac{d\gamma}{dr}(w_\varepsilon^p(x_3, (\cos \theta, \sin \theta)) - u(x_1^p + r \cos \theta, x_2^p + r \sin \theta, x_3))| , \\ & \leq M + M_3 \left| \log\left(\frac{r_\varepsilon}{R_\varepsilon}\right) \right|^{-1} . \end{aligned} \quad (45)$$

Finally, it is easy to verify that  $|\partial w_\varepsilon^p / \partial x_3|$  is bounded; then there exists  $M_4$  such that

$$\begin{aligned} & \left| \frac{\partial u_\varepsilon}{\partial x_3}(x_1^p + r \cos \theta, x_2^p + r \sin \theta, x_3) \right| \\ &= |(1 - \gamma(r)) \frac{\partial u}{\partial x_3}(x_1^p + r \cos \theta, x_2^p + r \sin \theta, x_3) \\ & \quad + \gamma(r) \frac{\partial w_\varepsilon^p}{\partial x_3}(x_3, (\cos \theta, \sin \theta))| \leq M_4 . \end{aligned} \quad (46)$$

The estimations (44), (45), (46) imply that  $|\nabla u_\varepsilon|$  is bounded on each layer  $C_\varepsilon^p$ , and thence on the set  $C_\varepsilon$ . As  $|C_\varepsilon|$  tends to 0, there follows  $\limsup \int_{C_\varepsilon} |\nabla u_\varepsilon|^2 dx = 0$  and

$$\limsup E^m(C_\varepsilon, u_\varepsilon) = 0 . \quad (47)$$

Assertion (iii) of Theorem 1 is proved by the estimations (42), (43) and (47).  $\square$

## 5 Comments

Due to the properties of  $\Gamma$ -convergence, our result is still valid when external body forces are present. Indeed, a term  $\int_\Omega f(x)u(x)dx$  can be added to both  $E_\varepsilon$  and  $E_0$ . In that way, we can solve non-trivial equilibrium problems.

Our result states that the homogenized material is a second gradient material: it has a ‘‘three dimensional bending stiffness’’  $k$ . This is not so surprising: it is well known that elastic cylinders, when their radius tends to zero, behave like rods (which are second gradient one-dimensional media): in a sense, we studied the homogenized properties of a system of rods connected by an elastic matrix. However, it must be emphasized that such a result could not be reached by considering directly an elastic matrix reinforced by one-dimensional rods (there is no interaction between a one-dimensional and an elastic three-dimensional medium).

The limit energy  $E_0$  contains a remaining classic elastic part,  $E^m(\Omega, u)$ . One could consider, afterwards, the limit  $(\mu_0, \lambda_0) \rightarrow (0, 0)$  in  $E_0$  and obtain an energy depending only on the second gradient of the displacement (the bending stiffness  $k$  does not depend on  $\mu_0$  or  $\lambda_0$ ).

The particular features of second gradient materials, like the hyperstress tensor [13, 14], flux of interstitial working [12, 10], edge forces [11], presence of a force distribution of order one with respect to the normal derivative [19] can be interpreted in our particular case as limits of some microscopic elastic forces.

An open question raised by our study is the general condition for the change of differential order of the energy when passing to the limit. We already pointed out that such a change was impossible for scalar problems. Our feeling is that the properties of the kernel of the energy density (rigid motions in our case) is essential: it leads to constraints verified by the limit of sequences with bounded energy (in our case these constraints (27) are stated in the proof of Lemma 6). They may be some partial differential equations

which increase the differential order of the energy. However, they also depend strongly on the geometry: for instance, we do not yet know whether it is possible to find a limit energy depending on a higher gradient of the displacement (third or higher order gradient material) by changing the distribution of the high rigidity inclusions.

*Acknowledgements.* This paper was initiated by enlightening discussions with M. Bellieud and G. Bouchitté who studied non-local effects for scalar problems in the same geometry [5, 4].

## References

1. Acerbi E Buttazzo G Percivale P (1988) Thin inclusions in linear elasticity: a variational approach, *J. Reine. Angew. Math.* 386, pp 99–113
2. Allaire G (1992) homogenization and two scale convergence, *SIAM J. Math. Anal.* 23, 6, pp 1482–1518
3. Barré de Saint-Venant A.J.C (1856) Mémoire sur la flexion des prismes, *Journal de Liouville*, 2ème série, t.1
4. Bellieud M. and Bouchitté G (1997) Homogénéisation de problèmes elliptiques en présence de fibres de grandes conductivité, *C. R. Acad. Sci. Paris.*, t. 323, série I, pp 1135–1140
5. Bellieud M (1997) Homogénéisation de problèmes elliptiques avec effets non locaux, Thèse de l'Université de Toulon
6. Beurling A Deny J (1959) Dirichlet spaces, *Proc. Nat. Acad. Sci. U.S.A.* 45, pp 208–215
7. Caillierie D (1981) Homogénéisation d'un corps élastique renforcé par des fibres minces de grande rigidité et réparties périodiquement, *C. R. Acad. Sc. Paris, Série II*, t.292, pp.477–480.
8. Cosserat E. and Cosserat F (1909) *Sur la théorie des corps déformables*, Herman, Paris.
9. Dal Maso (1993) *An introduction to  $\Gamma$ -convergence*. Progress in non linear differential equations and their applications, Birkhauser, Boston
10. Dell'Isola F. and Seppecher P (1995) The relationship between edge contact forces and interstitial working allowed by the principle of virtual power, *C. R. Acad. Sci.* t. 321, série IIb, pp 303–308
11. Dell'Isola F. and Seppecher P (1997) Edge Contact Forces and Quasi-Balanced Power, *Meccanica* 32, pp 33–52
12. Dunn J.E (1986) Interstitial working and non classical continuum thermodynamics, in *New perspectives in thermodynamics*, J. Serrin Ed., Springer Verlag, Berlin, pp 187–222
13. Germain P (1973) La méthode des puissances virtuelles en mécanique des milieux continus. Première partie: Théorie du second gradient, *Journal de Mécanique*, Vol. 12, N. 2, pp 235–274
14. Germain P (1973) The method of virtual power in continuum mechanics. Part 2: Microstructure, *S.I.A.M. J. Appl. Math.*, Vol. 25, N. 3, pp 556–575
15. Le Dret H (1991) *Problèmes variationnels dans les multi-domaines*, Research Notes in Applied Mathematics, Ciarlet, Lions Ed., Masson, Paris
16. Nguetseng G (1989) A general convergence result for a functional related to the theory of homogenization, *SIAM J. Math. Anal.* 20, 3, pp 608–623
17. Pideri C. and Seppecher P (1997) Un résultat d'homogénéisation pour un matériau élastique renforcé périodiquement par des fibres élastiques de très grande rigidité, *C. R. Acad. Sci. Paris*, t. 324, Série II b, pp 475–481
18. Sanchez-Palencia E (1980) *Non Homogeneous Media and Vibration Theory*, Springer-Verlag
19. Seppecher P (1989) Etude des conditions aux limites en théorie du second gradient: cas de la capillarité, *C. R. Acad. Sci. Paris*, t. 309, Série II, pp 497–502.
20. Seppecher P (1996) A numerical study of a moving contact line in Cahn-Hilliard theory, *Int. J. Engng. Sci.* Vol 34., No 9, pp.977–992