



**HAL**  
open science

# The Transferable Belief Model for reliability analysis of systems with data uncertainties and failure dependencies

Mohamed Sallak, Walter Schön, Aguirre Felipe

## ► To cite this version:

Mohamed Sallak, Walter Schön, Aguirre Felipe. The Transferable Belief Model for reliability analysis of systems with data uncertainties and failure dependencies. Proceedings of the Institution of Mechanical Engineers, Part O: Journal of Risk and Reliability, 2010, pp.00. hal-00522460v1

**HAL Id: hal-00522460**

**<https://hal.science/hal-00522460v1>**

Submitted on 30 Sep 2010 (v1), last revised 12 Nov 2010 (v2)

**HAL** is a multi-disciplinary open access archive for the deposit and dissemination of scientific research documents, whether they are published or not. The documents may come from teaching and research institutions in France or abroad, or from public or private research centers.

L'archive ouverte pluridisciplinaire **HAL**, est destinée au dépôt et à la diffusion de documents scientifiques de niveau recherche, publiés ou non, émanant des établissements d'enseignement et de recherche français ou étrangers, des laboratoires publics ou privés.

# The Transferable Belief Model for reliability analysis of systems with data uncertainties and failure dependencies

Mohamed Sallak, Walter Schön, and Felipe Aguirre

Compiegne University of Technology, UMR CNRS 6599

Heudiasyc BP 20529, 60205 Compiegne cedex, France

mohamed.sallak, walter.schon, felipe.aguirre-martinez@utc.fr

## ABSTRACT

Dealing with uncertainty adds a further level of complexity to problems of reliability analysis. The uncertainties which impact reliability studies usually involve incomplete or imprecise reliability data and complex failure dependencies. This paper proposes an original methodology based on the Transferable Belief Model (TBM) to include failure dependencies between components in the evaluation of the reliability of the whole system, given both epistemic and aleatory uncertainties. First, based on expert opinion and experimental data, Basic Probability Assignments (BPAs) are assigned to reliability data components. TBM operations are then used to obtain the reliability of the whole system, for series, parallel, series-parallel, parallel-series, and bridge configurations. Implicit, explicit, and discounting approaches are presented for taking account of failure dependencies. Finally, the proposed model is applied to take into account Common Cause Failures (CCFs) in a case study.

## KEY WORDS

Transferable Belief Model (TBM), Dempster-Shafer (D-S) theory, reliability analysis, Basic Probability Assignments (BPAs), epistemic uncertainty, failures dependencies, Common Causes Failures (CCFs).

## INTRODUCTION

Uncertainties are one of the most challenging problems in reliability studies of complex systems [1]–[3]. They are present in any reliability evaluation, owing to randomness in failure phenomena and the difficulty of obtaining failure data for components that fail only infrequently. Uncertainties have been classified into two subtypes: aleatory uncertainty and epistemic uncertainty. Aleatory uncertainty is also called irreducible, or inherent uncertainty. It is the inherent variation associated with the physical system or the environment under consideration [4]. Aleatory

uncertainty includes, for example, the inherent variability of failures and repair times of equipment. Epistemic uncertainty is subjective and reducible because it arises from a lack of knowledge or data. It represents the uncertainty of the outcome due to lack of knowledge or information in any phase or activity of the modeling process [4]. This uncertainty is associated with incompleteness in the analysts' state of knowledge and has an impact on the evaluation of system reliability. It is therefore important to take proper account of aleatory and epistemic uncertainties in any analysis of reliability.

In safety and reliability studies, the system's reliability at any time is evaluated using the probabilities of components failing at the same time. These failure probabilities are estimated using laboratory and generic reliability data provided by reliability databases [5]. However, using data from the laboratory and from generic data sources involves epistemic uncertainty. As mentioned by Kletz [6], because of operating conditions and environments, when using generic reliability data the reliability parameters for the components used can deviate by a factor of 3 or 4, and a factor of 10 is not unusual. Furthermore, according to Drouin *et al.* [7], uncertainties in probabilistic risk assessment are mainly epistemic.

In the presence of epistemic uncertainty, classical probability theories are based on the representation of failure probabilities of components at time  $t$  by Probability Density Functions (PDFs). The PDF  $f_i(x)$  at time  $t$  indicates the probability that the value of the failure probability for a component  $i$  at time  $t$  falls between  $x$  and  $x + dx$ . Classical probability theories based on Monte Carlo Simulations (MCS) can then be used to evaluate the reliability of the whole system. The D-S theory, which is a generalization of classical probability theory, can also be used to evaluate the reliability of the whole system, using Strat's technique [8], which allows belief mass functions to be derived from individual PDFs.

However, in some cases, there is not sufficient information about components' reliability data to derive PDFs. This is particularly frequent when systems have only rare component failures (nuclear systems, chemical processes, railway systems, etc.) or have not been operating long enough to provide valid statistical data. As an alternative to generic reliability data, expert knowledge/judgment is used [9]. In this work, the reliability parameters of components are based on expert judgment.

When using a classical probabilistic approach based on MCS with expert judgment, reliability researchers generally assume a log-normal or log-triangular distribution for the PDF for conventional reasons. This arbitrary choice of PDF can make the resulting reliability evaluation imprecise or even erroneous. The D-S theory does not need to assume a PDF for component failure. It allows a flexible representation of uncertainty for data sources of different types, and expert judgment in particular. Moreover, multiple expert knowledge can provide more reliable information for an observation (e.g., the failure probability of a component) than a single expert can. The expert judgment can often suffer from incompleteness and conflict. D-S theory addresses these issues effectively and is

able to combine multi-expert knowledge by taking into account ignorance and conflicts through a belief structure. The D-S representation is proposed in this paper as an attractive way of dealing with the issue at hand (expert judgment), without the use of unjustified assumptions concerning the PDF distribution. The D-S theory has several interpretations, such as the Transferable Belief Model (TBM). In this work the TBM is proposed for using expert judgment in order to evaluate the reliability of the whole system.

In many reliability studies failures of system components are assumed to be independent. However, in reality, different types of dependencies can be involved, rendering the results of reliability evaluations false. Fricks and Trivedi [10] have proposed a classification of failure dependencies (Common Cause Failures (CCFs), standby dependencies, etc.). There are two principal methods to model failure dependencies in system reliability analysis: implicit and explicit methods [11]. The implicit method is where joint probabilities, correlation values or conditional probabilities [12] are used. In explicit methods, the causes of dependencies are explicitly included in the system's logic model [12] as a block in Reliability Block Diagrams (RBDs) or a basic event in Fault Trees (FTs). Here we propose using the two approaches, together with an additional discounting approach, for reliability analysis using the TBM model.

## I. RELATED WORK

The first work introducing D-S theory in reliability analysis was presented by Dempster and Kong [13]. They proposed the use of an FT as a particular case of the tree of cliques to propagate beliefs through the tree. The prior beliefs of basic events of the tree represent prior failure beliefs of components. The second work was presented by Guth in 1991 [14] and concerned FT analysis. Guth represented the belief that a basic event  $A$  happens with failure probability  $p$  by three-valued logic (True, False and Unknown) and proposed truth tables with the three-valued logic in order to propagate the beliefs in FT. Chin et al. [15] proposed using evidence theory to capture the non-specificity and conflict features in judgments. The beliefs are then propagated in an FT in order to diagnose the fault distribution of web service process. Walley [16] and Kozine et al. [17] showed that in some applications the use of Dempster's combination rule led to incorrect results. Almond [18] developed graphical models using belief functions and applied this graphical model in FT analysis. Rakowsky et al. [19] have modeled uncertainties in Reliability-Centered Maintenance (RCM). They use belief and plausibility measures to express the uncertainties of experts in reasoning. They also use weighted recommendations during the RCM process. This approach was applied to a fire detection and extinguishing system. Pashazadeh et al. [20] proposed reliability assessment under epistemic uncertainty using D-S and vague set theories. They eliminated the gap between the representation of combined evidence and the representation of component reliability in the Vague Set theory. Simon et al. [21] have proposed combining Bayesian networks and D-S theory to study the reliability of systems given imprecise reliability data. They use evidential networks and junction tree inference algorithms.

There is very little work covering the use of TBM theory to model failure dependencies in reliability studies. Almond [18] proposed addressing the problem of dependency between basic events by using pivotal variables and information dependence breaking theorem. Walley [16] proposed an example which indicated that D-S theory is not well suited to handle dependency in the case of total ignorance of dependencies. An original TBM reliability analysis is therefore proposed in order to take into account failure dependencies in reliability evaluations.

## II. BASIC NOTIONS OF THE TRANSFERABLE BELIEF MODEL (TBM)

The TBM was introduced by Smets and Kennes [22] as a subjectivist interpretation of D-S theory. The D-S theory, also called evidence theory, was first described by Dempster in the 1960's [23] with the study of upper and lower probabilities and extended by Shafer in 1976 [24]. The TBM is a framework well suited for representing and manipulating aleatory and epistemic uncertainties. It is based on two levels: the credal level, where available pieces of information are represented by belief functions, and the pignistic or decision level, where belief functions are transformed into probability measures. It was originally applied in information fusion [25], [26], pattern recognition [27], [28] and diagnosis [29]. In a finite discrete space, the TBM can be interpreted as a generalization of probability theory where probabilities can be assigned to any subsets instead of singletons only. In this section, basic notions, extended operations, and the terminology of TBM are explained. For a more detailed presentation see [22]–[24].

### A. Frame of discernment

The frame of discernment  $X$  is the definition domain of the variable of interest  $\mathbf{x}$ . It consists of all mutually exclusive elementary propositions. It can be viewed as the sample space in probability theory. As an example, let us consider a frame of discernment  $X = \{x_1, x_2\}$ . Then,  $x_1$  and  $x_2$  are elementary propositions and mutually exclusive of each other. The power set  $2^X$  is the set of all the subsets of  $X$  including itself, i.e.:  $2^X = \{\emptyset, \{x_1\}, \{x_2\}, X\}$ .

### B. Basic Probability Assignment (BPA)

Probability theory is based on the definition of a probability space  $(X, M, P)$ , where  $X$  is the frame of discernment,  $P$  the probability function defined on a collection  $M$  of subsets (events)  $A_i$  of  $X$  that satisfies the properties of a  $\sigma$ -algebra, i.e.  $M$  is closed under complementation and countable unions, and it follows easily that it is also closed under countable intersections. The probability function  $P$ , a function mapping the collection of events  $M$  into  $[0, 1]$ , is required to respect  $P(X) = 1$  and  $P(\emptyset) = 0$  and to be sub-additive, i.e.:  $P(A \cup B) \leq P(A) + P(B)$ , and this inequality holds for any countable collection of disjoint events.

These properties are essential for understanding the differences with D-S theory. A Basic Probability Assignment (BPA) on  $X$ , also called a Basic Belief Assignment (BBA), is a function,  $m^X : 2^X \rightarrow [0, 1]$ , which maps probability

masses onto subsets of events, and not only onto events, such that:

$$\sum_{A \in 2^X} m^X(A) = 1. \quad (1)$$

The impact of a piece of evidence on an agent is translated by an allocation of parts of an initial unitary amount of belief among the subsets of frame of discernment. The number  $m^X(A)$  represents the part of the agent's belief that supports A [22]. A clear distinction has to be made between probabilities and basic belief assignment: probability distribution functions are defined on  $X$  and BPAs on the power set  $2^X$ . The number of possible hypotheses is then  $2^{\text{card}(X)}$  in D-S theory, while in probability theory it is  $\text{card}(X)$ . Moreover, D-S theory ignores the sub-additivity hypothesis required for probability functions in probability theory. The subsets  $A \subset X$  such that  $m^X(A) > 0$  are called focal sets of  $m^X$ . A BPA having a singleton  $\{x\}$  ( $x \in X$ ) as a unique focal set represents complete knowledge. A BPA having only singletons as focal sets is equivalent to probabilities. A BPA having  $X$  as a unique focal set represents complete ignorance and is called vacuous.

D-S includes an additional dimension of uncertainty when compared to a probabilistic model. BPAs can be assigned to subsets of events without distributing these BPAs further on events. For example, in the case of lack of knowledge, the expert is not obliged to assume a specific BPA for the occurrence of an event. This is why we say that the BPA is an incompletely defined probability space. Moreover, D-S theory is a generalization of the Bayesian theory of subjective probability. Whereas the Bayesian theory requires probabilities for each question of interest, BPAs allow us to base degrees of belief for one question on probabilities for a related question. This means that in reliability engineering, with D-S theory, we can take into account the reliability of experts, who give the BPAs for components failure, in the evaluation of the reliability of the whole system. In addition, BPA has further properties, which distinguishes it from being a probability function: refer Klir and Folger [30]:

- It is not required that  $m(X) = 1$ .
- It is not required that  $m(A) \leq m(B)$  when  $A \subseteq B$ .
- No relationship between  $m(A)$  and  $m(\bar{A})$ .
- Also  $m(A) + m(\bar{A})$  does not always have to be 1.

*Belief and plausibility functions:*

The belief *Bel* and plausibility *Pl* functions for a subset  $A$  are defined as follows:

$$Bel(A) = \sum_{B \subseteq A} m^X(B) \quad \text{and} \quad Pl(A) = \sum_{B \cap A \neq \emptyset} m^X(B) \quad \text{for any} \quad A \subseteq X \quad (2)$$

$Bel(A)$  measures the total assignment of belief to  $A$  and all its subsets. The plausibility function measures the extent to which we fail to disbelieve the hypothesis of  $A$ .  $[Bel(A), Pl(A)]$  can be viewed as the confidence interval

which describes the uncertainty of A. The functions  $Bel$  and  $Pl$ , although they too are functions mapping events A onto  $[0, 1]$ , and mapping  $\emptyset$  onto 0 and  $\Omega$  into 1, do not fulfill in the general case the sub-additivity properties given for probability.

### C. Combination rules

Consider two distinct pieces of evidence  $m_i^X$  and  $m_j^X$  from two different sources  $i$  and  $j$ . In TBM, the principal combination rules are the conjunctive and disjunctive combination rules [24]. The conjunctive combination is given by:

$$m_{i \odot j}^X(H) = \sum_{A \cap B = H, \forall A, B \subseteq X} m_i^X(A) m_j^X(B), \forall H \subseteq X \quad (3)$$

The disjunctive combination is given by:

$$m_{i \oplus j}^X(H) = \sum_{A \cup B = H, \forall A, B \subseteq X} m_i^X(A) m_j^X(B), \forall H \subseteq X \quad (4)$$

Dempster's rule of combination is defined as the conjunctive combination of two normal BPAs followed by normalization. This rule is also called the orthogonal sum of evidence. It is defined as follows:

$$m_{i \oplus j}^X(H) = \frac{\sum_{A \cap B = H, \forall A, B \subseteq X} m_i^X(A) m_j^X(B)}{1 - \sum_{A \cap B = \emptyset, \forall A, B \subseteq X} m_i^X(A) m_j^X(B)} \quad (5)$$

The number defined by  $k = \sum_{A \cap B = \emptyset, \forall A, B \subseteq X} m_i^X(A) m_j^X(B)$  is called the conflict factor between the two pieces of evidence  $i$  and  $j$ .

As some reliability researchers [16], [17] have pointed out, Dempster's rule sometimes generates incorrect conclusions in the case of serious conflict between evidence. In this case, it is recommended to investigate the given information or to collect more information. Several combination rules have been defined and they often differ in the way the evidence mass of an empty intersection is allocated [31], [32].

### D. Discounting

It sometimes occurs that a source of information induces a BPA  $m^X$ , but there is some doubt regarding the reliability of this source. Such metaknowledge may be represented by discounting [24]  $m^X$  by some factor  $\delta \in [0, 1]$ , which leads to a BPA  $m_\delta^X$  defined as:

$$m_\delta^X(A) = (1 - \delta) m^X(A) \quad \forall A \subseteq X, A \neq X \quad (6)$$

$$m_\delta^X(X) = \delta + (1 - \delta) m^X(X) \quad (7)$$

A discount rate  $\delta = 1$  means that the source can certainly not be trusted: the resulting BPA is then vacuous. In contrast, a null discount rate leaves  $m^X$  unchanged: this corresponds to the situation where the source is known to be fully reliable.

### E. Coarsening and Refinement

The first step in TBM is to define the frame of discernment. As noted by Shafer [24], the degree of granularity of the frame is always, to some extent, a matter of convention, since any element representing a state can always be split into several possibilities. Hence, it is fundamental to examine how a belief function defined on a frame may be expressed in a finer or, conversely, in a coarser frame [24], [33].

Consider two finite sets  $X$  and  $Y$ . A mapping  $\rho : 2^Y \rightarrow 2^X$  is called a refining if it verifies:

- $\rho(B) = \bigcup_{y \in B} \rho(\{y\}) \quad \forall B \subseteq Y$ .
- The set  $\{\rho(y), y \in Y\} \subseteq 2^X$  is a partition of  $X$ .

$Y$  is called a coarsening of  $X$ , and  $X$  is called a refinement of  $Y$ .

A BPA  $m^Y$  on  $Y$  can be transformed into a BPA  $m^X$  on a refinement  $X$  by transferring each mass  $m^Y(B)$  for  $B \subseteq Y$  to  $m^X(A)$  for  $A = \rho(B)$ . This operation is called a vacuous extension of  $m^Y$  to  $X$ . It is defined as follows:

$$m^X(A) = \begin{cases} m^Y(B) & \text{if } A = \rho(B) \text{ for some } B \subseteq Y \\ 0 & \text{otherwise.} \end{cases} \quad (8)$$

### F. Operations on Joint Spaces

Consider a BPA  $m^{X \times Y}$  defined on the Cartesian product  $X \times Y$ . The marginal BPA  $m^{X \times Y \downarrow X}$  on  $X$  is defined by:

$$m^{X \times Y \downarrow X}(A) = \sum_{B \subseteq X \times Y / Proj(B \downarrow X) = A} m^{X \times Y}(B) \quad \forall A \subseteq X \quad (9)$$

Where  $Proj(B \downarrow X) = \{x \in X / \exists y \in Y, (x, y) \in B\}$ . The inverse operation is a particular instance of vacuous extension. Consider a BPA  $m^X$  defined on  $X$ . Its vacuous extension on  $X \times Y$  is defined by:

$$m^{X \uparrow X \times Y}(B) = \begin{cases} m^X(A) & \text{if } B = A \times Y \text{ for some } A \subseteq X \\ 0 & \text{otherwise.} \end{cases} \quad (10)$$

Let  $m^{XY}$  denote a BPA on  $X \times Y$  (with underlying variables  $(\mathbf{x}, \mathbf{y})$ ), and  $m_y^{XY}$  the BPA on  $X \times Y$  with single focal set  $X \times \{y\}$ . The conditional BPA of  $\mathbf{x}$  given  $\mathbf{y} = y$  is defined as:

$$m^X[y] = (m^{XY} \odot m_y^{XY}) \downarrow X \quad (11)$$



The conditioning operation for belief functions has the same meaning as in Probability Theory. However, it also admits an inverse operation called the ballooning extension. Let  $m^X[y]$  denote the conditional BPAs on  $X$ , given  $y$ . The ballooning extension of  $m^X[y]$  on  $X \times Y$  is the least committed BPA whose conditioning on  $y$  yields  $m^X[y]$ . It is obtained as:

$$m^{X[y]\uparrow^{XY}}(B) = \begin{cases} m^X[y](A) & \text{if } B = (A \times \{y\}) \cup (X \times (Y \setminus \{y\})) \text{ for some } A \subseteq X, \\ 0 & \text{otherwise.} \end{cases} \quad (12)$$

In order to optimize the TBM operations and save time and space, some computation algorithms were given in [18], [34].

### III. THE PROPOSED TBM RELIABILITY ANALYSIS

In this paper, both system and components have only two possible states: either working ( $W$ ) or failed ( $F$ ) (*i.e.* we make the so-called *Binary State assumption*). Using BPAs of functioning and failed system components, the goal is to obtain the reliability of the whole system in the case of series, parallel, series-parallel, parallel-series and bridge configurations.

#### A. Frame of discernment

In virtue of the Binary State assumption, the frame of discernment  $X_i$  of a component  $i$  is given by  $X_i = \{F_i, W_i\}$ .  $F_i$  and  $W_i$  represent respectively the failure and the working states of the component  $i$ . The study is started by considering a simple system  $S$  composed of two components 1 and 2. The frames of discernment of components 1, 2 and  $S$  are then:  $X_1 = \{F_1, W_1\}$ ,  $X_2 = \{F_2, W_2\}$  and  $X_S = \{F_S, W_S\}$ .

#### B. BPAs, belief and plausibility functions of system components

BPA structure is a more natural and intuitive way to express one's degree of belief in a hypothesis where only partial evidence is available. In reliability studies, based on expert opinion and experimental data, BPAs of components are computed directly and this computation requires some efforts from a reliability expert. The BPAs assigned to system components by expert opinion and experimental data can be then expressed by:

$$m^{X_i}(\{F_i\}) = f_i; m^{X_i}(\{W_i\}) = w_i; m^{X_i}(\{W_i, F_i\}) = 1 - w_i - f_i \quad ; \quad i = 1, 2 \quad (13)$$

Using Eq. (2), the belief and plausibility functions of components 1 and 2 are computed. For example, if component 1 is considered, then:  $Bel(\{F_1\}) = m^{X_1}(\{F_1\})$  and  $Pl(\{F_1\}) = m^{X_1}(\{F_1\}) + m^{X_1}(\{F_1, W_1\})$ .

### C. Assignment of BPAs for component failure

The BPAs for the different component reliability parameters are acquired from different sources. In safety and reliability engineering, data are usually taken from generic data or based on expert judgment [35]. In the present study, BPAs are directly obtained from experts because there is not enough reliability data from reliability databases covering the components used in the system under consideration. The TBM postulates that the impact of a piece of evidence on an expert is translated by an allocation of parts of an initial unitary amount of belief among the propositions (the subsets) of  $X_i = \{F_i, W_i\}$ . For a subset  $Y$  of  $X_i$ ,  $m^{X_i}(Y)$  is a part of the expert's belief that supports  $Y$ . For example, an expert 1 may report having a 0.7 part of belief supporting the proposition "component  $A$  is working at time  $t$ ". The same expert reports having a 0.1 part of belief supporting the proposition "component  $A$  is not working at time  $t$ ". Mathematically, this can be written as  $m_1^{X_A}(\{W_A\}) = 0.7$ ,  $m_1^{X_A}(\{F_A\}) = 0.1$  and  $m_1^{X_A}(\{W_A, F_A\}) = 0.2$ , because  $m_1^{X_A}(\{W_A, F_A\}) = 1 - m_1^{X_A}(\{W_A\}) - m_1^{X_A}(\{F_A\})$ . Obviously, the BPA  $m_1^{X_A}(\{W_A, F_A\})$  represents the epistemic uncertainty of the expert concerning the functioning of component  $A$  at time  $t$  due to lack of information.

The problem we now face is how to combine two or more BPAs from different experts regarding the same component  $A$ . Several combination rules were defined in D-S theory. In this work, we assume the independence of different experts' opinions. This is why we use Dempster's rule of combination. Now, let us assume that another expert 2 reports as follows in relation to the same component  $A$ :  $m_2^{X_A}(\{W_A\}) = 0.8$ ,  $m_2^{X_A}(\{F_A\}) = 0.15$  and  $m_2^{X_A}(\{W_A, F_A\}) = 0.05$ . These two independent assessments for the same component can be combined using the D-S combination rule. The conflict factor is then  $k = 0.1850$ . The BPAs obtained are  $m_{1\oplus 2}^{X_A}(\{W_A\}) = 0.9264$ ,  $m_{1\oplus 2}^{X_A}(\{F_A\}) = 0.0613$  and  $m_{1\oplus 2}^{X_A}(\{W_A, F_A\}) = 0.0123$ .

Dempster's rule satisfies the properties of associativity, commutativity and non-idempotence. However, two major limitations of this rule are its lack of robustness in the presence of highly conflicting information ( $k \mapsto 1$ ), and the requirement that the sources of information must be independent. The problem of conflict has been addressed by several authors, who have proposed rules which are generally not associative [33]. The other important limitation of Dempster's rule lies in the assumption that the BPAs must be distinct, i.e, the experts' opinions must be independent. The idea is that in combination operations no elementary BPAs should be counted twice. This problem was addressed by Ling et al. [36], who proposed a rule limited to the combination of belief functions having at most two focal sets including the frame of discernment. Elouedi et al. [37] extended this method to belief functions that can be decomposed as the conjunctive sum of simple belief functions. Denoeux [38] proposed a commutative, associative and idempotent cautious rule for belief functions which are not separable. This cautious rule generalizes a method proposed by Kennes [39] for combining separable BPAs induced by non-distinct items of evidence, based on an application of category theory to evidential reasoning. These rules provide reliability analysis with an appropriate

	Parallel system	Series system
<b>BPAs</b>		
$m^{X_S}\{F_S\}$	$\prod_{i=1}^n f_i$	$1 - \prod_{i=1}^n (1 - f_i)$
$m^{X_S}\{W_S\}$	$1 - \prod_{i=1}^n (1 - w_i)$	$\prod_{i=1}^n w_i$
$m^{X_S}\{F_S, W_S\}$	$\prod_{i=1}^n (1 - w_i) - \prod_{i=1}^n f_i$	$\prod_{i=1}^n (1 - f_i) - \prod_{i=1}^n w_i$
$Bel\{W_S\}$	$1 - \prod_{i=1}^n (1 - w_i)$	$\prod_{i=1}^n w_i$
$Pl\{W_S\}$	$1 - \prod_{i=1}^n f_i$	$\prod_{i=1}^n (1 - f_i)$
$R_S$	$[1 - \prod_{i=1}^n (1 - w_i), 1 - \prod_{i=1}^n f_i]$	$[\prod_{i=1}^n w_i, \prod_{i=1}^n (1 - f_i)]$

TABLE I: BPAs and reliability of parallel and series systems with  $n$  components

means of taking account of non-independent expert judgments. In this work, we assume the absence of significant conflicts between experts' opinions, as well as their independence.

#### D. Evaluation of BPAs, beliefs and plausibility functions of the whole system $S$

First, vacuous extension is used to extend  $m^{X_1}$  and  $m^{X_2}$  to the product space  $X_1 \times X_2 \times X_S$ . The resulting BPAs are combined using Dempster's rule. Then, the resulting BPAs are combined with  $m_{Config}^{X_1 \times X_2 \times X_S}$  which represents the system configuration. The BPA  $m_{Config}^{X_1 \times X_2 \times X_S}$  represents the relation between the system  $S$  and its components 1 and 2. It is given by:

$m_{Series}^{X_1 \times X_2 \times X_S}(\{(W_1, W_2, W_S), (F_1, F_2, F_S), (F_1, W_2, F_S), (W_1, F_2, F_S)\}) = 1$  for a series configuration.

And  $m_{Parallel}^{X_1 \times X_2 \times X_S}(\{(W_1, W_2, W_S), (F_1, F_2, F_S), (F_1, W_2, W_S), (W_1, F_2, W_S)\}) = 1$  for a parallel configuration. To obtain BPAs of system  $S$ , the final result is marginalized on  $X_S$ . Belief and plausibility functions are then computed from  $m^{X_S}$ . Formally, the final BPA is defined as follows:

$$m^{X_S} = (m^{X_1 \uparrow X_1 \times X_2 \times X_S} \oplus m^{X_2 \uparrow X_1 \times X_2 \times X_S} \oplus m_{Config}^{X_1 \times X_2 \times X_S}) \downarrow_{X_S} \quad (14)$$

The system's reliability  $R_S$  is then given by  $R_S \in [Bel(\{W_S\}), Pl(\{W_S\})]$

1) *Parallel configuration*: The results of BPAs related to parallel configuration can be generalized to  $n$  ( $1 \leq i \leq n$ ) components with BPAs  $f_i$ ,  $w_i$ , and  $1 - f_i - w_i$  (cf. Table I).

2) *Series configuration*: The results of BPAs related to series configuration can be generalized to  $n$  ( $1 \leq i \leq n$ ) components with BPAs  $f_i$ ,  $w_i$ , and  $1 - f_i - w_i$  (cf. Table I).

3) *Series-parallel, parallel-series, and complex configurations*: BPAs of series-parallel and parallel-series systems are evaluated by calculating the BPAs for the individual series and parallel sections and then combining them. For complex configurations, minimal paths are used to find the truth table for the functioning system ( $x_i = 1$  if the component  $i$  is up and 0 if the component is down). The different combinations in the truth table are then used to define the unique focal element of the BPA  $m_{config}$  indicating if the system is working  $W_S$  or failed  $F_S$  in all  $2^n$  combinations of component states.

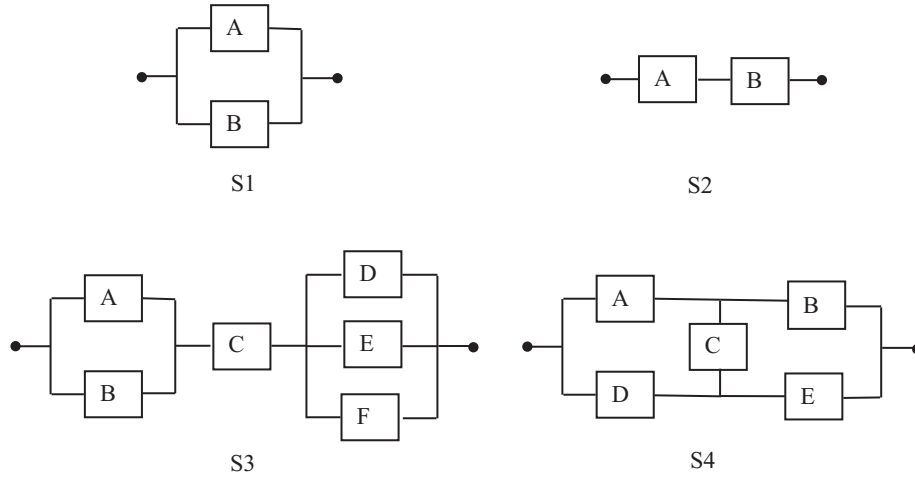

Fig. 1: RBDs of systems: S1, S2, S3 and S4

Components	Probabilistic	TBM		
	approach	approach		
	$P_i$	$m^{X_i}(\{F_i\})$	$m^{X_i}(\{W_i\})$	$m^{X_i}(\{F_i, W_i\})$
A	0.1	0.1	0.9	0
B	0.2	0.2	0.8	0
C	0.15	0.15	0.85	0
D	0.3	0.3	0.7	0
E	0.05	0.05	0.95	0
F	0.35	0.35	0.65	0

TABLE II: Case I: BPAs and failure probabilities of components  $A$ ,  $B$ ,  $C$ ,  $D$ ,  $E$  and  $F$ 

### E. Numerical application: two cases

- Case I: Aleatory uncertainty

Consider four systems (cf. Figure 1): a simple series system with 2 components  $A$  and  $B$ , a simple parallel system with 2 components  $A$  and  $B$ , a parallel-series system with 6 components  $A$ ,  $B$ ,  $C$ ,  $D$ ,  $E$ , and  $F$ , and a bridge system with 5 components  $A$ ,  $B$ ,  $C$ ,  $D$ , and  $E$ . Let us consider only aleatory uncertainty for components  $A$ ,  $B$ ,  $C$ ,  $D$ ,  $E$  and  $F$ , as shown in Table II (there is no epistemic uncertainty about components, *i.e.*  $m^{X_i}(\{F_i, W_i\}) = 0$ ). In order to compare our approach with a classical probabilistic approach, we use BPAs in the TBM approach, and crisp failure probabilities of components  $P_i$  in the conventional probabilistic approach (cf. Table II). In this case, it is well known that  $P_i = m^{X_i}(\{F_i\})$  for each component  $i$ . The system reliabilities for S1, S2, S3 and S4 are then computed using the TBM model and the probabilistic approach based on minimal cut-sets [40]. As we expected, we obtain the same results for the reliabilities of all four systems with the two approaches (cf. Table III).

#### Case II: Aleatory and epistemic uncertainty

We now consider epistemic uncertainty for components  $A$ ,  $B$ ,  $D$  and  $F$ , as shown in Table V. The present probabilistic method of determining the system's reliabilities involves representing the epistemic component

Systems	TBM approach	Probabilistic approach
	$R_S$	$R_S$
$S1$	0.980	0.980
$S2$	0.720	0.720
$S3$	0.829	0.829
$S4$	0.958	0.958

TABLE III: Case I: Reliability of systems:  $S1$ ,  $S2$ ,  $S3$  and  $S4$ 

$A$	$m^{X_1 \times X_2 \times X_S}(A)$
$\{(F_1, F_2, F_S)\}$	$f_1 f_2$
$\{(F_1, W_2, W_S)\}$	$f_1 w_2$
$\{(F_1, F_2, F_S), (F_1, W_2, W_S)\}$	$f_1(1 - w_2 - f_2)$
$\{(W_1, F_2, W_S)\}$	$w_1 f_2$
$\{(W_1, W_2, W_S)\}$	$w_1 w_2$
$\{(W_1, W_2, W_S), (W_1, F_2, W_S)\}$	$w_1(1 - w_2 - f_2)$
$\{(F_1, F_2, F_S), (W_1, F_2, W_S)\}$	$f_2(1 - w_1 - f_1)$
$\{(F_1, W_2, W_S), (W_1, W_2, W_S)\}$	$w_2(1 - w_1 - f_1)$
$\{(W_1, W_2, W_S), (F_1, F_2, F_S), (F_1, W_2, W_S), (W_1, F_2, W_S)\}$	$(1 - w_1 - f_1)(1 - w_2 - f_2)$

TABLE IV: BPAs results of simple parallel system without dependencies

failure probabilities by a specified PDF (log-normal, normal, triangular, etc.). The PDF  $f_i(x)$  at time  $t$  indicates the probability that the value of the failure probability of a component  $i$  at time  $t$  falls between  $x$  and  $x+dx$ . In order to compare our results with those obtained by a classical probabilistic approach, the epistemic uncertainty will be represented by a log-normal PDF which is defined by a median  $m$  and an error factor (EF) obtained from the BPAs as follows:

$$Bel(\{F_i\}) = \frac{m_i}{EF_i}$$

In this probabilistic approach, the @FAULT TREE + software package developed by ISOGRAPH is used to generate minimal cut-sets and system reliabilities. It uses Monte-Carlo sampling simulations to repeatedly sample component failure probabilities from the appropriate distributions, and to calculate and record the system's reliabilities. The confidence interval of the probabilistic approach is 99%. Table VI presents the results computed by the TBM and by probabilistic approaches. Table IV also gives analytical expressions for parallel system  $S1$  of focal sets and corresponding BPAs before marginalization on  $X_S$ . It shows that the differences between results obtained using these two different approaches are very small. However, the width of the support defined by the probabilistic approach is higher than the width of the support in the TBM approach. By assuming a log-normal PDF for system and component failures, we introduce more uncertainty into the probabilistic approach.

Components	Probabilistic approach		TBM approach		
	$m_i$	$EF_i$	$m^{X_i}(\{F_i\})$	$m^{X_i}(\{W_i\})$	$m^{X_i}(\{F_i, W_i\})$
<i>A</i>	0.25	1.25	0.2	0.7	0.1
<i>B</i>	0.075	1.50	0.05	0.9	0.05
<i>C</i>	0.180	1	0.18	0.82	0
<i>D</i>	0.175	1.75	0.1	0.75	0.15
<i>E</i>	0.050	1	0.05	0.95	0
<i>F</i>	0.08	2.67	0.03	0.87	0.1

TABLE V: Case II: BPAs and parameters of log-normal PDF of components *A*, *B*, *C*, *D*, *E* and *F*

Systems	TBM approach	Probabilistic approach
	$R_S$	Confidence Interval (99%) $R_S$
<i>S1</i>	[0.9700, 0.9900]	[0.9630, 0.9912]
<i>S2</i>	[0.6300, 0.7600]	[0.5975, 0.7716]
<i>S3</i>	[0.7941, 0.8117]	[0.7891, 0.8123]
<i>S4</i>	[0.9156, 0.9753]	[0.8873, 0.9759]

TABLE VI: Case II: Reliability of systems: *S1*, *S2*, *S3* and *S4*

#### IV. MODELING FAILURE DEPENDENCIES IN TBM RELIABILITY ANALYSIS

##### A. Introduction

Nowadays, complex systems use redundant components in order to increase the overall system reliability. However, redundant systems are usually subject to multiple failure dependencies [41]. CCFs were the most frequently studied failure dependency models. Reliability researchers have usually integrated CCFs in the system reliability model (FT [11], RBD [42], stochastic Petri nets [10], etc.). Other failure dependencies were integrated implicitly by increasing the failure rates of components [12]. The use of BPAs is proposed to represent failure dependencies, and extended operations defined in TBM reliability analysis to obtain the whole system's reliability. Implicit, explicit, and discounting approaches will be presented. Numerical results show the differences between the three approaches.

##### B. The implicit approach

Let us consider a simple system *S* composed of two components 1 and 2 in parallel. BPAs of components 1 and 2 are given in Eq. 15. Suppose that reliability experts performing functional system tests have observed that the failure of component 2 leads to the failure of component 1 in  $\gamma_1$  cases. The factor  $\gamma_1$  is called the dependency factor. Let us also suppose that these experts have indicated the BPAs of components 1 and 2 (cf. Eq. 15). The goal is to evaluate the system reliability  $R_S$  given this information.

$$m^{X_i}(\{F_i\}) = f_i; m^{X_i}(\{W_i\}) = w_i; m^{X_i}(\{W_i, F_i\}) = 1 - w_i - f_i \quad ; \quad i = 1, 2 \quad (15)$$

The proposed implicit approach is to code the dependency between components 1 and 2 by the conditional BPAs:

$$m^{X_1}[F_2](\{F_1\}) = \gamma_1 \quad (16)$$

$$m^{X_1}[F_2](\{W_1, F_1\}) = 1 - \gamma_1 \quad (17)$$

The ballooning extension is used to decondition the BPAs in Eq.16 and Eq.17 to  $X_1 \times X_2$ . The BPAs obtained are then vacuous extended to  $X_1 \times X_2 \times X_S$  and combined using Dempster's rule with the BPAs of the simple parallel configuration and the BPAs of components 1 and 2 extended to  $X_1 \times X_2 \times X_S$ . The final results after marginalization on  $X_S$  are given in Table VII. The factor  $\gamma_1$  can be viewed as a correlation factor which assigns an additional BPA to the failure of component 1, given the failure of component 2. Note that this conditional BPA (cf. Eq. 16) introduces a conflict factor  $k_1 = \gamma_1 f_2 w_1$ .

### C. The explicit approach

We now again consider the parallel system  $S$  referred to above. Let  $M$  be a virtual component with two states,  $E$  and  $I$ . The  $E$  state indicates the presence of CCFs. In this case, the components 1 and 2 are both failed ( $F_1, F_2$ ) or both working ( $W_1, W_2$ ). The  $I$  state indicates the absence of CCFs. In this case, all states are possible for components 1 and 2. These two assumptions are coded by the conditional BPAs:

$$m^{X_1 \times X_2}[E](\{(F_1, F_2), (W_1, W_2)\}) = 1 \quad (18)$$

$$m^{X_1 \times X_2}[I](\{(F_1, F_2), (F_1, W_2), (W_1, W_2), (W_1, F_2)\}) = 1 \quad (19)$$

The frame of discernment of  $M$  is then given by  $X_M = \{E, I\}$  and the BPAs related to  $M$  are given by:

$$m(\{E\}) = \delta_1; m(\{I\}) = \delta_2; m(\{E, I\}) = 1 - \delta_1 - \delta_2 \quad (20)$$

The BPAs of Eq.18 and Eq.19 are deconditioned to  $X_1 \times X_2$ . The BPAs obtained and the BPAs of Eq. 20 are extended to  $X_1 \times X_2 \times X_S \times X_M$ . The obtained BPAs are then combined with the BPAs of the parallel structure. The final results after marginalization on  $X_S$  are given in Table VII. The factor  $\delta_1$  can be viewed as a correlation factor which assigns an additional BPA to the fact that components 1 and 2 are either both working or failed, knowing the state  $E$  of virtual component  $M$ . The factor  $\delta_2$  assigns a mass value to the fact that the components 1 and 2 may have all possible states. Since the BPA is vacuous, given the state  $I$  of component  $M$ ,  $\delta_2$  does not appear in the final results. Note that in this case, the BPA of Eq. 18 also introduces a conflict factor  $k_2 = \delta_1(f_1 w_2 + f_2 w_1)$ .

BPA	$m^{X_S}(\{F_S\})$	$m^{X_S}(\{W_S\})$
Implicit approach	$\frac{f_1 f_2 + \gamma_1 (f_2 - f_2 w_1 - f_1 f_2)}{1 - k_1}$	$\frac{w_1 + w_2 - w_1 w_2 - \gamma_1 w_1 f_2}{1 - k_1}$
Explicit approach	$\frac{f_1 f_2 + \delta_1 (f_1 + f_2 - f_1 w_2 - f_2 w_1 - 2 f_1 f_2)}{1 - k_2}$	$\frac{w_1 + w_2 - w_1 w_2 - \delta_1 (f_1 w_2 + f_2 w_1)}{1 - k_2}$
Discounting approach	$\frac{f_1 f_2}{1}$	$\frac{w_1 w_2 + w_1 (1 - f_2 - w_2) + w_2 (1 - f_1 - w_1) + (1 - \mu_1) (f_1 w_2 + f_2 w_1)}{1}$

TABLE VII: Implicit, explicit, and discounting approaches: BPAs of system  $S$  ( $k_1 = \gamma_1 f_2 w_1$  and  $k_2 = \delta_1 (f_1 w_2 + f_2 w_1)$ )

#### D. The discounting approach

We now return again to the system  $S$  referred to above. The BPAs of components 1 and 2 are given in Eq. 20. There are several discounting approaches [24] in literature. Our discounting operation involves weakening, in the BPAs of Table IV which assume independence, the cases  $(F_1, W_2, W_S)$  and  $(W_1, F_2, W_S)$ , by applying a factor  $1 - \mu_1$  ( $\mu_1 \in [0, 1]$ ), while adding the BPAs  $\mu_1 m(\{(F_1, W_2, W_S)\})$  and  $\mu_1 m(\{(W_1, F_2, W_S)\})$  to the case of total ignorance  $\{(W_1, W_2, W_S), (F_1, F_2, F_S), (F_1, W_2, W_S), (W_1, F_2, W_S)\}$  (cf. Eq. 21, 22, and 23). The corresponding BPAs in Table IV are then modified accordingly. Final results after marginalization on  $X_S$  are given in table VII.

$$m_d(\{(F_1, W_2, W_S)\}) = (1 - \mu_1) \cdot m(\{(F_1, W_2, W_S)\}) \quad (21)$$

$$m_d(\{(W_1, F_2, W_S)\}) = (1 - \mu_1) \cdot m(\{(W_1, F_2, W_S)\}) \quad (22)$$

$$m_d(\{(W_1, W_2, W_S), (F_1, F_2, F_S), (F_1, W_2, W_S), (W_1, F_2, W_S)\}) = \quad (23)$$

$$m(\{(W_1, W_2, W_S), (F_1, F_2, F_S), (F_1, W_2, W_S), (W_1, F_2, W_S)\}) + \mu_1 \cdot m(\{(W_1, F_2, W_S)\}) + \mu_1 \cdot m(\{(F_1, W_2, W_S)\})$$

#### E. Comparison between approaches

To illustrate the three approaches, the BPAs of components  $A$  and  $B$  defined in Table V (Case II) are used. The BPAs and reliability of system  $S$  are then computed as a function of dependency factors  $\gamma_1$ ,  $\delta_1$ , and  $\mu_1$  (cf. Figure 2). In the three cases, as would be expected, the reliability of system  $S$  decreases as factors  $\gamma_1$ ,  $\delta_1$ , and  $\mu_1$  increase. The explicit approach models CCFs, because the virtual component  $M$  allows us to model any condition or event that affects several components, inducing their simultaneous failure. In the case of several CCFs, The number of components is higher than in the implicit approach (each type  $i$  of CCFs will be modeled by a virtual component  $M_i$ ). Furthermore, the discounting approach means that the BPAs of components can be revised during system operation. For example, if in a functioning system, uncertainty concerning a given component's state is increased as a result of some external event, a discounting operation can be performed on the associated BPAs by  $m^*(\{W_i\}) = t \cdot m(\{W_i\})$ ,  $m^*(\{F_i\}) = t \cdot m(\{F_i\})$  and  $m^*(\Omega) = (1 - t) + t \cdot m(\Omega)$  where  $\Omega = \{W_i, F_i\}$  ( $0 \leq t \leq 1$ ).



Fig. 2: Implicit, explicit and discounting approaches: Reliability of system  $S$  as a function of dependency factors  $\gamma_1$ ,  $\delta_1$ , and  $\mu_1$

Components	$m^{X_i}(\{F_i\})$	$m^{X_i}(\{W_i\})$	$m^{X_i}(\{F_i, W_i\})$
$CP_1$	0.15	0.82	0.03
$CP_2$	0.06	0.88	0.06
$CP_3$	0.15	0.85	0
$GM_1$	0.1	0.89	0.01
$GM_2$	0.2	0.74	0.06

TABLE VIII: Case study: BPAs of components

## V. CASE STUDY

The complexity within a railway system lies not in any particular technical aspect, although these are complicated, but in the interactions and relationships between the different components. Particularly, there are a number of subsystems which present complicated dependencies.

Let us consider a system composed of a computer with 3 power supplies and two operated subsystems for self-diagnosis of failures [43]. The first subsystem (cf. Figure 3) is composed of two redundant global memories ( $GM_1$  and  $GM_2$ ) in series with a 2 out of 3 control processors ( $CP_1$ ,  $CP_2$  and  $CP_3$ ). The second operated subsystem is composed of one global memory ( $GM_1$ ) in series with a 1 out of 3 ( $CP_1$ ,  $CP_2$  and  $CP_3$ ) control processors. This kind of system is often used for a safety-critical signaling system such as automatic train stop. It is supposed that only if both subsystems fail, then the total system fails dangerously. Subsystems have two failure modes: the first due to the use of subsystems and the second due to the failure of power supplies. The power supplies configuration is not static. It's a function of the solicitation of the operated subsystems, and may have a 1 out of 3 or a 2 out of 3 configurations. That's why it is too difficult to model the power supplies in the RBD of the whole system. The study is only concerned by CCFs induced by power supplies. Since the two subsystems share a common power supply, it may happen a failure of power supplies which induces the common mode failures of both subsystems. Reliability experts give BPAs of failure components (cf. Table VIII). The objective is to evaluate the whole system's reliability as a function of the BPA of the CCFs. The case study illustrates the case when CCFs are induced by power supplies.

First, the Typed State Influence Diagram (TSID) of system (cf. Figure 3) is presented in order to identify the whole system states as a function of the components states. The BPAs of subsystems  $A$  and  $B$  are computed, and it is assumed that  $m(CCFs) = \chi$  ( $0 \leq \chi \leq 1$ ). The three approaches defined above are used to evaluate the system's reliability as a function of the presence of CCFs considering that  $\chi = \gamma_1 = \delta_1 = \mu_1$  and  $\delta_2 = 1 - \delta_1$ . This means that in the case study there is no epistemic uncertainty regarding the presence of CCFs. The epistemic uncertainty concerns only the system components' failure data. The probabilistic approach is based on the use of log-normal PDFs (see section III.E) and the beta model [12] defined in @FAULT TREE + which assumes

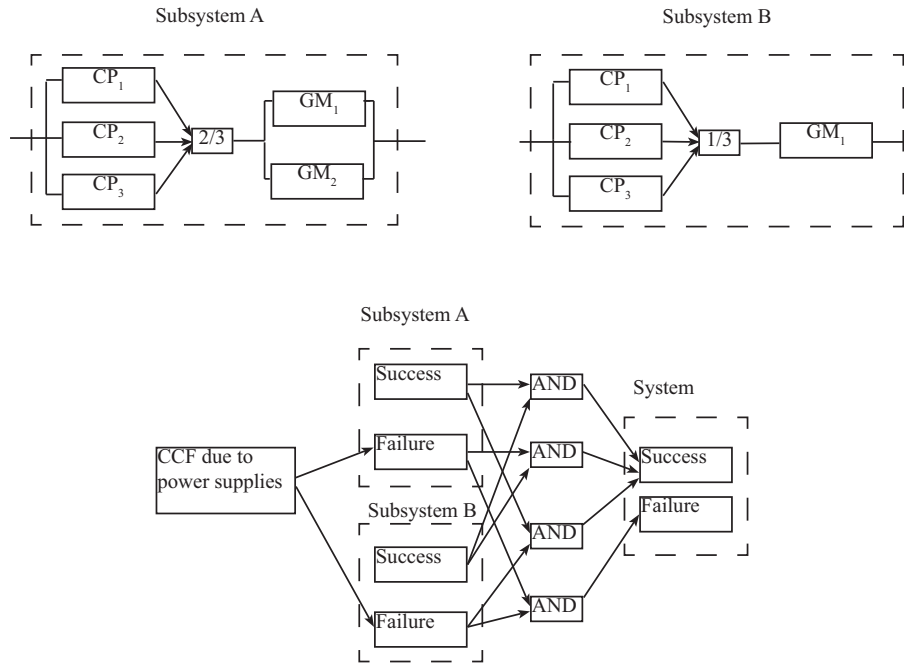

Fig. 3: RBDs of subsystems A and B and TSID of the whole system

$\chi$	TBM approaches						Probabilistic approach Confidence Interval (99%) $R_S$
	Explicit approach $R_S$		Implicit approach $R_S$		Discounting approach $R_S$		
	$R_S$	$k$	$R_S$	$k$	$R_S$	$k$	
0	[0.9964, 0.9978]	0	[0.9964, 0.9978]	0	[0.9964, 0.9978]	0	[0.9964, 0.9979]
0.1	[0.9964, 0.9977]	0.0098	[0.9964, 0.9977]	0.0117	[0.9847, 0.9978]	0	[0.9958, 0.9974]
0.2	[0.9963, 0.9975]	0.0196	[0.9963, 0.9976]	0.0234	[0.9730, 0.9978]	0	[0.9950, 0.9970]
0.3	[0.9963, 0.9974]	0.0294	[0.9963, 0.9975]	0.0351	[0.9614, 0.9978]	0	[0.9942, 0.9965]
0.4	[0.9962, 0.9972]	0.0392	[0.9963, 0.9973]	0.0468	[0.9497, 0.9978]	0	[0.9933, 0.9960]
0.5	[0.9962, 0.9970]	0.0490	[0.9962, 0.9972]	0.0584	[0.9380, 0.9978]	0	[0.9924, 0.9954]
0.6	[0.9962, 0.9968]	0.0588	[0.9962, 0.9970]	0.0701	[0.9263, 0.9978]	0	[0.9914, 0.9948]
0.7	[0.9961, 0.9967]	0.0686	[0.9962, 0.9969]	0.0818	[0.9146, 0.9978]	0	[0.9903, 0.9941]
0.8	[0.9961, 0.9965]	0.0784	[0.9961, 0.9967]	0.0935	[0.9029, 0.9978]	0	[0.9892, 0.9934]
0.9	[0.9960, 0.9963]	0.0882	[0.9961, 0.9966]	0.1052	[0.8912, 0.9978]	0	[0.9880, 0.9927]
1	[0.9959, 0.9961]	0.0980	[0.9960, 0.9964]	0.1169	[0.8795, 0.9978]	0	[0.9868, 0.9920]

TABLE IX: Case study: system’s reliability and conflict factors

to add a proportion  $\beta$  due CCFs to the failures probabilities of components, i.e for each component  $i$  we have  $P_T(i) = P_I(i) + P_{CCF}(i)$  and  $P_{CCF}(i) = \beta \cdot P_I(i)$  where  $P_T(i)$ ,  $P_I(i)$ , and  $P_{CCF}(i)$  are respectively the total failure probability, the independent failure probability, and the failure probability due to CCFs of component  $i$ . In this case, the factor  $\beta$  is equal to  $\chi$ . Results show that CCFs tend to decrease significantly the overall system reliability in all the cases (cf. Table IX). Compared to explicit and implicit approaches, discounting and probabilistic approaches introduce more uncertainty regarding system reliability. Note that the fairly low values of the conflict factors provide an *a posteriori* justification of the use of Dempster’s rule in this work.

## VI. CONCLUSIONS AND FUTURE WORK

The TBM theory has recently attracted the attention of the reliability engineering community. This paper presents an original approach for taking account of failure dependencies in reliability evaluations, given both epistemic

and aleatory uncertainties. First, the proposed TBM reliability model was applied to evaluate the reliability of series, parallel, series-parallel, parallel-series and bridge systems in the presence of both epistemic and aleatory uncertainties. The TBM model was then incorporated into implicit, explicit and discounting methods for handling failure dependencies in reliability evaluations. Finally, the model was applied to take into account CCFs in evaluating the reliability of a system composed of a computer with dual-operated subsystems for the self-diagnosis of failures. Future research tasks include the application of the TBM reliability model in FT analysis. Other failure dependency models (beta factor, load-sharing, etc.) will also be included in future work.

## REFERENCES

- [1] K. D. Raoa, H. Kushwahaa, A. Vermab, and A. Srividyaab, "Quantification of epistemic and aleatory uncertainties in level-1 probabilistic safety assessment studies," *Reliability Engineering and System Safety*, vol. 92, pp. 947–956, 2007.
- [2] E. Zio, "Reliability engineering: Old problems and new challenges," *Reliability Engineering and System Safety*, vol. 94, pp. 125–141, 2009.
- [3] R. L. Winkler, "Uncertainty in probabilistic risk assessment," *Reliability Engineering and System Safety*, vol. 54, pp. 127–132, 1996.
- [4] W. L. Oberkampf, J. C. Helton, C. A. Joslyn, S. F. Wojtkiewicz, and S. Ferson, "Challenge problems: uncertainty in system response given uncertain parameters," *Reliability Engineering and System Safety*, vol. 85, pp. 11–19, 2004.
- [5] Exida, *Safety Equipment Reliability Handbook*. 2nd Edition, 2005.
- [6] T. A. Kletz, *Identifying and assessing process industry hazards*. 4th Edition, Institution of chemical engineers, 1999.
- [7] M. Drouin, G. Parry, J. Lehner, G. Martinez-Guridi, J. LaChance, and T. Wheeler, *Guidance on the Treatment of Uncertainties Associated with PRAs in Risk-informed Decision making*. Report, NUREG1855-V.1, 2009.
- [8] T. M. Strat and J. D. Lowrance, *Evidential Reasoning with Continuous Variables*. Technical Note, Artificial Intelligence Center, SRI International, Menlo Park, California, 1999.
- [9] T. Rosqvist, *On the use of expert judgement in the qualification of risk assessment*. Thesis, Helsinki University of Technology, Finland, 2003.
- [10] R. M. Fricks and K. S. Trivedi, "Modeling failure dependencies in reliability analysis using stochastic petri nets," *Proceedings of European Simulation Multiconference (ESM 97), Istanbul, Turkey, 1997*.
- [11] J. Vaurio, "Common cause failure probabilities in standby safety system fault tree analysis with testingscheme and timing dependencies," *Reliability Engineering and System Safety*, vol. 79, pp. 43–57, 2003.
- [12] Misra and B. Krichna, *Handbook of Performability Engineering*. Springer Verlag, 2008.
- [13] A. Dempster and A. Kong, "Uncertain evidence and artificial analysis," *Journal of Statistical Planing and Inference*, vol. 20, pp. 355–368, 1988.
- [14] M. Guth, "A probabilistic foundation for vagueness and imprecision infault-tree analysis," *IEEE Transactions on Reliability*, vol. 40, pp. 563–571, 1991.
- [15] W. C. Chin and V. Ramachandran, "Evidence sets approach for web service fault diagnosis," *Malaysian Journal of Computer Science*, vol. 13, pp. 84–89, 2000.
- [16] P. Walley, *Statistical reasoning with imprecise probabilities*. New York : Chapman and Hall, 1991.
- [17] I. Kozine and Y. Filimonov, "Imprecise reliabilities: experiences and advances," *Reliability Engineering and System Safety*, vol. 67, pp. 75–83, 2000.
- [18] R. G. Almond, *Graphical belief modeling*. Chapman and Hall, 1995.

- [19] U. K. Rakowsky and U. Gocht, "Reasoning in reliability-centred maintenance based on a dempstershafer approach," *Proceedings of the Institution of Mechanical Engineers, Part O: Journal of Risk and Reliability*, vol. 222, pp. 605–612, 2008.
- [20] S. Pashazadeh and M. Sharifi, "Reliability assessment under uncertainty using dempster-shafer and vague set theories," *Computational Intelligence for Measurement Systems and Applications, CIMSA 2008*, vol. 1, pp. 131–136, 2008.
- [21] G. Shafer, P. P. Shenoy, and K. Mellouli, "Evidential networks for reliability analysis and performance evaluation of systems with imprecise knowledge," *IEEE Transactions on Reliability*, vol. 58, pp. 69–87, 2009.
- [22] P. Smets and R. Kennes, "The transferable belief model," *Artificial Intelligence*, vol. 66, pp. 191–243, 1994.
- [23] A. P. Dempster, "Upper and lower probabilities induced by multivalued mapping," *Annals of Mathematical Statistics*, vol. 38, pp. 325–339, 1967.
- [24] G. Shafer, *A Mathematical Theory of Evidence*. Princeton University Press, 1976.
- [25] S. Fabre, A. Appriou, and X. Briottet, "Presentation and description of two classification methods using data fusion based on sensor management," *Information Fusion*, vol. 2, pp. 49–71, 2001.
- [26] D. Mercier, G. Cron, T. Denoeux, and M. Masson, "Fusion of multi-level decision systems using the transferable belief model," *Proceedings of FUSION 2005, Philadelphia*, 2005.
- [27] T. Denoeux, "Application of evidence theory to k-nn pattern classification," *Pattern Recognition in Practice IV, Elsevier, Amsterdam*, pp. 13–24, 1994.
- [28] E. Hullermeier, "Similarity-based inference as evidential reasoning," *International Journal of Approximate Reasoning*, vol. 26, pp. 67–100, 2001.
- [29] P. Smets, "The application of the transferable belief model to diagnosis problems," *International Journal of Intelligent Systems*, vol. 13, pp. 127–158, 1998.
- [30] G. J. Klir and T. A. Folger, *Fuzzy Sets, Uncertainty and Information*. Englewood Cliffs. Prentice-Hall., 1999.
- [31] K. Sentz and S. Ferson, *Combination of evidence in DempsterShafer theory*. Sandia National Laboratories, 2002.
- [32] P. Smets, "The combination of evidence in the transferable belief model," *IEEE Transactions on Pattern Analysis and Machine Intelligence*, vol. 12, pp. 447–458, 1990.
- [33] S. Demotier, W. Schon, and T. Denoeux, "Risk assessment based on weak information using belief functions: A case study in water treatment," *IEEE Transactions on Systems, Man, and Cybernetics*, vol. 32, pp. 382–396, 2006.
- [34] G. Shafer, P. P. Shenoy, and K. Mellouli, "Propagating belief functions in qualitative markov trees," *International Journal of Approximate Reasoning*, vol. 1, pp. 349–400, 1987.
- [35] A. O'Neil, *The Dempster-Shafer Engine*. <http://www.quiver.freereserve.co.uk/Dse.htm>, 1999.
- [36] X. Ling and W. Rudd, "Combining opinions from several experts," *Applied Artificial Intelligence*, vol. 3, pp. 439–452, 1989.
- [37] Z. Elouedi and K. Mellouli, "Pooling dependent expert opinions using the theory of evidence," *Proc. of the Seventh Int. Conf. on Information Processing and Management of Uncertainty in Knowledge-Based Systems*, vol. 1, pp. 32–39, 1998.
- [38] T. Denoeux, "The cautious rule of combination for belief functions and some extensions," *Proceedings of FUSION'2006, Florence, Italy, July 2006*, vol. 43, pp. 22–25, 2008.
- [39] R. Kennes, "Evidential reasoning in a categorical perspective: conjunction and disjunction of belief functions." *Uncertainty in AI 91*, pp. 174–181, 1991.
- [40] R. Billinton, *Reliability Evaluation of Engineering Systems, Concepts and Techniques*. Plenum Press, Second Edition, 1992.
- [41] Y. Haiyang, C. Chengbin, E. Chatelet, and F. Yalaoui, "Reliability optimization of a redundant system with failure dependencies," *Reliability Engineering and System Safety*, vol. 92, pp. 1627–1634, 2007.
- [42] S. Distefano and A. Puliafito, "Dynamic reliability block diagrams vs dynamic fault trees," *Reliability and Maintainability Symposium, Orlando, USA, 2007*.

- [43] H. Fukuoka, "Reliability evaluation method for the railway system: a model for complicated dependency," *Quarterly Report of Railway Technical Research Institute*, vol. 43, pp. 192–197, 2002.