



HAL
open science

Economic Performance Optimization of an Absorption Cooling System under Uncertainty

Berhane H. Gebreslassie, Gonzalo Guillén-Gosálbez, Laureano Jiménez, Dieter Boer

► **To cite this version:**

Berhane H. Gebreslassie, Gonzalo Guillén-Gosálbez, Laureano Jiménez, Dieter Boer. Economic Performance Optimization of an Absorption Cooling System under Uncertainty. *Applied Thermal Engineering*, 2009, 29 (17-18), pp.3491. <10.1016/j.applthermaleng.2009.06.002>. <hal-00521249>

HAL Id: hal-00521249

<https://hal.science/hal-00521249v1>

Submitted on 27 Sep 2010

HAL is a multi-disciplinary open access archive for the deposit and dissemination of scientific research documents, whether they are published or not. The documents may come from teaching and research institutions in France or abroad, or from public or private research centers.

L'archive ouverte pluridisciplinaire **HAL**, est destinée au dépôt et à la diffusion de documents scientifiques de niveau recherche, publiés ou non, émanant des établissements d'enseignement et de recherche français ou étrangers, des laboratoires publics ou privés.



HAL Authorization

Accepted Manuscript

Economic Performance Optimization of an Absorption Cooling System under Uncertainty

Berhane H. Gebreslassie, Gonzalo Guillén-Gosálbez, Laureano Jiménez, Dieter Boer

PII: S1359-4311(09)00179-3
DOI: [10.1016/j.applthermaleng.2009.06.002](https://doi.org/10.1016/j.applthermaleng.2009.06.002)
Reference: ATE 2828

To appear in: *Applied Thermal Engineering*

Received Date: 13 March 2009
Revised Date: 1 June 2009
Accepted Date: 2 June 2009

Please cite this article as: B.H. Gebreslassie, G. Guillén-Gosálbez, L. Jiménez, D. Boer, Economic Performance Optimization of an Absorption Cooling System under Uncertainty, *Applied Thermal Engineering* (2009), doi: [10.1016/j.applthermaleng.2009.06.002](https://doi.org/10.1016/j.applthermaleng.2009.06.002)

This is a PDF file of an unedited manuscript that has been accepted for publication. As a service to our customers we are providing this early version of the manuscript. The manuscript will undergo copyediting, typesetting, and review of the resulting proof before it is published in its final form. Please note that during the production process errors may be discovered which could affect the content, and all legal disclaimers that apply to the journal pertain.

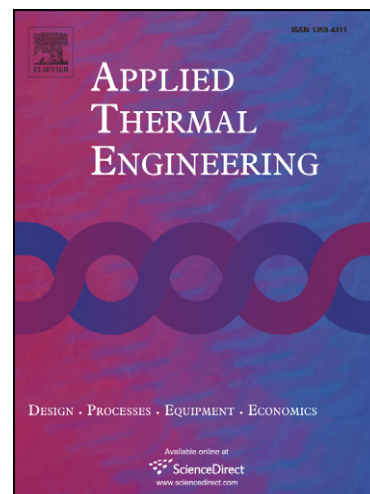

Economic Performance Optimization of an Absorption Cooling System under Uncertainty

Berhane H. Gebreslassie ^a, Gonzalo Guillén-Gosálbez ^b,
Laureano Jiménez ^b and Dieter Boer ^{a,*}

^a *Department of Mechanical Engineering, University Rovira i Virgili
Av. Països Catalans, 26, 43007, Tarragona, Spain*

^b *Department of Chemical Engineering, University Rovira i Virgili
Av. Països Catalans, 26, 43007, Tarragona, Spain*

Abstract

Many of the strategies devised so far to address the optimization of energy systems are deterministic approaches that rely on estimated data. However, in real world applications there are many sources of uncertainty that introduce variability into the decision-making problem. Within this general context, we propose a novel approach to address the design of absorption cooling systems under uncertainty in the energy cost. As opposed to other approaches that optimize the expected performance of the system as a single objective, in our method the design task is formulated as a stochastic bi-criteria non-linear optimization problem that simultaneously accounts for the minimization of the expected total cost and the financial risk associated with the investment. The latter criterion is measured by the downside risk, which avoids the need to define binary variables thus improving the computational performance of the model. The capabilities of the proposed modeling framework and solution strategy are illustrated in a case study problem that addresses the design of a typical absorption cooling system. Numerical results demonstrate that the method presented allows to manage the risk level effectively by varying the area of the heat exchangers of the absorption cycle. Specifically, our strategy allows identifying the optimal values of the operating and design variables of the cycle that make it less sensitive to fluctuations in the energy price, thus improving its robustness in the face of uncertainty.

Key words: Absorption refrigeration, Stochastic programming, Multi-objective optimization, Uncertainty, Ammonia-water, Energy cost

* Corresponding author. E-mail: Dieter.Boer@urv.cat

1 Introduction

Energy plays an important role in supporting our daily life, economic development and every human activity. Energy systems are complex as they involve various economic, technical, environmental, legal and political factors [1, 2]. Due to the limitation of fossil energy resources, the impact on the environment, and the human health problems during the last decades, there has been a growing interest on developing modeling and optimization strategies for energy systems. In this challenging scenario, absorption cycles have emerged as a promising alternative in cooling and refrigeration applications, as they use refrigerant with zero global warming potential that do not contribute to the ozone layer depletion [3, 4]. Moreover, another advantage of these systems is that they can use different forms of primary energy sources such as fossil fuels, renewable energy sources, and also waste heat recovered from other thermal systems.

Unfortunately, these systems require higher number of units than conventional vapor compression cycles, which leads to higher investment costs. Hence, there is a clear need to develop strategies able to optimize their design and operation from a thermodynamic and economic point of view so they can become a real alternative to the standard compression systems. Specifically, most of the methods proposed so far to accomplish this task rely on the concept of thermoeconomic analysis [5–7], an approach that combines in a single framework both, a thermodynamic model (usually based on exergy considerations) and an economic model (i.e., a cost model).

An alternative strategy that has been widely applied in the optimization of process industries is the simultaneous approach based on mathematical programming [8]. In this second method, the design task is posed as an optimization problem that is solved via standard techniques for linear, nonlinear, mixed-integer linear and mixed-integer nonlinear (LP, NLP, MILP, MINLP, respectively) programming. Although these strategies have been extensively used in the optimization of chemical processes (see [9]), their application to the design of absorption cooling systems has been rather limited, and only a few works can be found in the area [10, 11]. The authors deal the optimization of an ammonia-water absorption cycle by application of mixed-integer nonlinear programming but their approach was limited to a deterministic approach.

Most of the strategies that address the optimization of thermal systems following either of the aforementioned approaches are deterministic. That is, they are typically based on nominal or estimated values for all the input data considered in the analysis [5, 12–17]. This means that the key parameters that influence the optimization task are assumed to be perfectly known in advance, so the only situation assessed in the study is the most likely one. This type

of strategies lead to decisions by far too optimistic, in which the variability of the parameters of the problem is disregarded. However, in real world applications there are many sources of uncertainty that introduce variability into the decision-making problem. This is especially true in the optimization of energy systems, in which the availability of energy sources, technology performance, energy cost and end user cooling and heating demand, among many others, are affected by a high degree of uncertainty [2, 18–21].

In the process system engineering literature, the inclusion of uncertainty issues in the decision-making procedure has recently emerged as an active area of research. There are currently three main approaches that address optimization under uncertainty (for a detailed review see [19]): (1) stochastic programming [22–28], (2) fuzzy programming [1, 2, 20, 29, 30] and (3) stochastic dynamic programming [31]. The main applications of these tools have focused on process design [33–35], planning and scheduling of process plants [23, 27, 28, 36–38] and also on the design and planning of entire chemical supply chains [22, 26, 39]. On the other hand, in the modeling and optimization of energy systems, uncertainty considerations have been usually neglected. Whereas there are few works that account for uncertainty issues in the planning of energy systems [1, 2, 20, 29, 30], to our knowledge the design under uncertainty of such systems has not yet been addressed.

Specifically, Cai et al. [2] studied the identification of optimal strategies for energy management planning where the total cost, energy demand, technology efficiency and energy import costs are considered as uncertain and represented by fuzzy sets. Lin et al. [1] have addressed the energy system planning by integration of interval-parameter and fuzzy programming into a two stage stochastic programming framework to handle energy demand uncertainty. Sadeghi et al. [20] studied the energy supply planning in Iran using fuzzy models to represent the investment cost uncertainty. Mavrotas et al. [29] used fuzzy linear programming to optimize energy planning in buildings by considering the fuel costs as uncertain or fuzzy parameters. Svensson et al. [32] developed a methodology for identifying robust process integration investments under uncertainty using a real options approach. Taylor et al. [40] performed an uncertainty analysis on the design of piping systems, piping networks, and cross-flow heat exchangers. The authors showed that uncertainty analysis is a viable paradigm for energy system analysis and design.

The objective of this work is to address the design of absorption cooling systems under uncertainty in the energy cost. The main novelties of this work are: (1) the explicit consideration of uncertainty issues at the design stage of absorption cooling cycles, and (2) the development of a bi-criteria mathematical model that employs risk management techniques to deal with the associated decision-making problem under uncertainty. The approach presented relies on formulating the design task as a stochastic non-linear programming problem

(NLP) that accounts for the simultaneous minimization of the expected total cost and the financial risk of the investment. The capabilities of our modeling framework and solution strategy are illustrated through a case study problem, for which the set of Pareto solutions that represent the optimal compromise between cost and risk are obtained.

2 Problem Statement

2.1 System Description (Absorption Cycle)

Compared to a compression cooling cycle, the basic idea of an absorption system is to replace the electricity consumption associated with the vapor compression by a thermally driven absorption-desorption system [4]. This is accomplished by making use of absorption and desorption processes that employ a suitable working fluid pair. The working pair consists of a refrigerant and an absorbent. In this study, without loss of generality, an ammonia/water solution is used as working pair, with the ammonia being the refrigerant and water the absorbent.

Fig. 1 represents the considered absorption cycle in a pressure - temperature plot. The system provides chilled water for cooling applications and is steam driven. The basic components are the absorber (A), condenser (C), desorber (D) and evaporator (E). The cycle also includes the refrigerant subcooler (SC), refrigerant expansion valve (RV), solution heat exchanger (SHX), solution pump (P), and solution expansion valve (SV). The high pressure equipments are the solution heat exchanger, desorber, and condenser, whereas the low pressure ones are the evaporator and absorber.

The system operation is as follows. The refrigerant in vapor phase (stream 14) coming from the subcooler (SC) is absorbed in the absorber (A) by the diluted liquid solution (stream 6). The concentrated solution (stream 1) leaving the absorber is pumped by pump (P) to reach a higher pressure (stream 2) before being preheated in the solution heat exchanger (SHX). Then, the solution (stream 3) enters the desorber, in which the desorption of ammonia takes place. In this work, only the stripping section of the desorber is considered. Vapor refrigerant (stream 9) from the desorber condenses completely in the condenser (C). The liquid refrigerant (stream 10) from the condenser is then subcooled (stream 11) in the subcooler (SC) by the superheating stream (stream 13) that comes from the evaporator (E). The liquid refrigerant (stream 11) flows to the evaporator (E) through the refrigerant expansion valve (RV). The weak liquid solution (stream 4) from the desorber returns back to the absorber (A) through the solution heat exchanger (SHX), which preheats the concentrated

solution (stream 2) before being introduced to the desorber. From the heat exchanger, the solution is finally sent to the expansion valve (SV), and then to the absorber (A).

Note that streams 15 to 22 are external heat transfer fluids. In our case, water is used for energy supply and energy extracting. The useful output energy is the heat extracted in the evaporator (Q_E), whereas the input energy is supplied to the desorber (Q_D). The system includes a low pressure steam boiler where the primary energy resources are fossil fuels. For the sake of simplicity, the process of steam production has not been included in our model. However, the model could be easily modified in order to account for such a system.

Specifically, in this work we address the optimal design of an absorption cooling cycle like the one described before under uncertainty in the energy cost. Given are the cooling capacity of the system, the inlet and outlet temperatures of the external fluids and capital cost data. It is assumed that the energy cost cannot be perfectly forecasted, and that its variability can be represented by a set of scenarios with a given probability of occurrence. Hence, the goal of our study is to determine the optimal design and associated operating conditions that simultaneously minimize the total expected cost of the cycle and its risk level.

Note that, in general, the impact that the energy cost variability has in the overall economic performance of a process may vary from one type of industry to another, and will depend on the percentage of the total expenses that are due to the energy consumption. Furthermore, the energy consumption of a process industry and hence the energy cost, can be properly tuned by adjusting the associated design variables. Standard deterministic methods tend to optimize the economic performance of a process considering mean energy cost values. Stochastic methods can lead to more robust designs, in which the energy consumption is reduced in order to make the system less sensitive to fluctuations in the energy price. This allows to decrease the probability of unfavorable scenarios with large energy expenses.

3 Multi-objective Stochastic Model

This section introduces the mathematical model derived to address the problem described above. Specifically, in our work, the design task is posed as a multi-scenario bi-criteria NLP problem that simultaneously minimizes the expected total cost of the investment and its risk level. The solution of this problem is defined by a set of trade-off alternatives, each of which involves different structural and operating features. The choice of a scenario-based approach is motivated by the fact that it can deal with any type of probability

distribution. This can be accomplished by using sampling techniques, such as a Monte Carlo sampling, that allow generating a set of representative scenarios from any type of probability function.

The mathematical model of the cycle is based on the one introduced by the authors in [41]. The major difference between the formulation presented in [41] and that described next is that in the latter one the model only considers the stripping section of the distillation, as proposed by Roriz et al. [42]. Note that since the evaporation temperature is above 0°C, the enrichment process of ammonia in the rectification column does not bring significant performance improvement [43]. For the sake of completeness of this paper, we next discuss the main features of the formulation. The reader is referred to the original work for more technical details. Specifically, the model is based on the following assumptions:

- Steady state operation.
- Heat losses are not considered.
- Pressure losses are not considered.
- The refrigerant leaves the condenser as a saturated liquid.
- The solutions leave the absorber and desorber as saturated liquids.
- The solution and refrigerant valves are adiabatic.

The mathematical formulation includes two main parts: (1) general constraints (see section 3.1) and (2) objective function related constraints (see sections 3.2.1 and 3.2.2) that allow to assess the economic and risk performance of the cycle. Both parts are described in detail in the following sections.

3.1 General Constraints

As mentioned before, these equations are added to enforce the mass and energy conservation. These principles are applied to all the units of the cycle, each of which is treated as a control volume with inlet and outlet streams, heat transfer and work interactions [4] (see Fig. 2). This is accomplished via the following equation:

$$\sum_{j \in IN(k)} m_j x_{i,j} - \sum_{j \in OUT(k)} m_j x_{i,j} = 0 \quad \forall k, i \quad (1)$$

Eq. (1) represents the mass balances, and states that the total amount of component i that enters unit k must equal the total amount of i that leaves k . In this equation, m_j denotes the mass flow of stream j , and $x_{i,j}$ is the mass fraction of component i in stream j . Note that j can be either an inlet or outlet stream. Hence, in this equation $IN(k)$ denotes the set of inlet streams

of unit k , whereas $OUT(k)$ represents the set of outlet streams.

$$\sum_{j \in IN(k)} m_j h_j - \sum_{j \in OUT(k)} m_j h_j + Q_k^{IN} - Q_k^{OUT} - W_k = 0 \quad \forall k \quad (2)$$

Eq. (2) defines the energy balances in the system assuming no heat losses. The difference in energy content between the inlet and outlet streams, plus the heat supplied to the unit (Q_k^{IN}) must equal the heat removed (Q_k^{OUT}) plus the work done (W_k) by the unit. Note that the heat and work terms in Eq. (2) can take a zero value in some of the units, as shown in Eqs. (3) to (5):

$$Q_k^{IN} = 0 \quad \text{if } k = \left\{ \begin{array}{l} \text{Absorber (A)} \\ \text{Condenser (C)} \\ \text{Subcooler (SC)} \\ \text{Solution heat exchanger (SHX)} \\ \text{Pump (P)} \\ \text{Expansion valves (RV, SV)} \end{array} \right\} \quad (3)$$

$$Q_k^{OUT} = 0 \quad \text{if } k = \left\{ \begin{array}{l} \text{Evaporator (E)} \\ \text{Desorber (D)} \\ \text{Subcooler (SC)} \\ \text{Solution heat exchanger (SHX)} \\ \text{Pump (P)} \\ \text{Expansion valves (RV, SV)} \end{array} \right\} \quad (4)$$

$$W_k = 0 \quad \forall k \neq \text{pump} \quad (5)$$

Furthermore, the enthalpy of a stream is determined from its temperature (T), pressure (P), and composition, as stated in Eq. (6)

$$h_j = f(T_j, P_j, x_{i,j}) \quad \forall j \quad (6)$$

Specifically, the model makes use of the correlations proposed by Pátek and Komfar [44] to estimate the thermodynamic properties of the ammonia-water mixture.

The heat exchangers are modeled using the logarithmic mean temperature difference (ΔT_k^{lm}), the heat transfer area (A_k) and the overall heat transfer coefficient (U_k), as shown in Eq. (7).

$$Q_k = U_k A_k \Delta T_k^{lm} \quad \forall k \quad (7)$$

The logarithmic mean temperature difference, which is a function of the hot and cold end temperature differences (ΔT_k^h and ΔT_k^c , respectively), is calculated via the Chen's approximation. This avoids the discontinuity of the function at $\Delta T_k^h = \Delta T_k^c$, which in turn improves the robustness of the mathematical formulation and its numerical performance [41].

$$\Delta T_k^{lm} \cong \left[\Delta T_k^h \Delta T_k^c \frac{\Delta T_k^h + \Delta T_k^c}{2} \right]^{\frac{1}{3}} \quad \forall k \quad (8)$$

The coefficient of performance (COP) is determined via Eq. (9) as the ratio between the energy extracted from the chilled water and the total energy supplied to the system [4].

$$COP = \frac{Q_{k=E}}{Q_{k=D} + W_{k=P}} \quad (9)$$

3.2 Objective Function

As mentioned before, the model considers that the energy cost is uncertain and that its variability can be described through a set of scenarios with given probability of occurrence. As a result, the cost associated with the construction and operation of a cycle is not a single nominal value, instead it is a stochastic variable that follows a discrete probability function. In this context, the optimization method must identify the set of solutions (i.e., cycles) that simultaneously minimize the expected value of the cost distribution as well as its risk level.

The traditional approach to address optimization under uncertainty relies on formulating a single-objective optimization problem where the expected performance of the system is the objective to be optimized. This strategy does not allow controlling the variability of the objective function in the uncertain space. In other words, optimizing the expected economic performance of a cycle does not imply that the process will yield better results at a certain level considering the whole cost distribution. The underlying idea in risk management is to incorporate the trade-off between financial risk and expected cost within the decision-making procedure. This gives rise to a multi-objective optimization problem in which the expected performance and a specific risk measure are the objectives considered. The solution of such a problem is given by a set of Pareto solutions that represent the optimal trade-off between expected performance and risk level. Specifically, in our work, the probability of meeting unfavorable scenarios is controlled by considering the downside risk as an additional objective to be minimized.

3.2.1 Expected Cost Performance

The expected total cost $E[TC]$, which is given by the mean value of the discrete distribution of the cost, can be calculated as follows:

$$E[TC] = \sum_s prob_s TC_s \quad (10)$$

where TC_s is the total cost corresponding to the realization of each scenario s , and $prob_s$ is the probability of occurrence of such scenario. Note that the set of scenarios considered in the analysis must be provided as input data by the decision-maker. In the cases where the uncertain parameters follow certain types of probability functions, they can be obtained, for instance, by performing a sampling on them.

The total annualized cost in each scenario s accounts for both, the capital and operating costs of the cycle (CC and CO_s , respectively):

$$TC_s = CC + CO_s \quad (11)$$

As can be observed, the uncertainty in the energy price only affects the operating cost. Hence, the capital cost is not scenario dependent, whereas the value of the operating cost depends on the specific scenario realization. The assumption of a deterministic capital investment is justified by the fact that this type of cost is usually agreed before the construction of the equipment, so it can be perfectly known in advance. On the other hand, the operating cost tends to fluctuate according to the market trends, so it cannot be predicted accurately at the design stage.

The annualized capital cost includes the cost of the heat exchangers (C_{hxs}), pumps (C_p) and expansion valves (C_{exp}) times the capital recovery factor (cr)

$$CC = (C_{hxs} + C_p + C_{exp}) cr \quad (12)$$

The cost of the heat exchangers can be estimated using the linear correlation proposed by Kizilkan et al.[6].

$$C_{hxs} = \sum_{k=heat\ exchange} (c_1 A_k + c_2) \quad (13)$$

In Eq. (13), c_1 and c_2 are the variable and fixed cost parameters, respectively, associated with the heat exchangers used in the system. These parameters relate the area of a heat exchanger with its cost. The cost of the pump can be calculated using the correlation introduced by Siddiqui [45]:

$$C_p = c_3 W_p^{0.4} \quad (14)$$

where W_p denotes the pump power, and c_3 is a cost parameter. It should be noticed that in many applications the cost of the expansion valves can be

neglected, since their contribution to the system cost is usually rather small. The capital recovery factor (cr) is a function of the interest rate (ir) and the life span (i.e., number of useful years, n) of the unit under consideration [7]:

$$cr = \frac{ir (ir + 1)^n}{(ir + 1)^n - 1} \quad (15)$$

Finally, the total annualized operating cost includes the cost of the steam used in the desorber, the electricity consumed by the pump and the cooling water. Usually, the latter term can be neglected compared to the remaining ones, so the operating cost can be finally calculated as follows:

$$CO_s = (cq_s Q_{k=D} + ce_s W_{k=P}) t_{op} \quad (16)$$

In this equation, cq_s and ce_s are the unitary costs of heat and electricity in scenario s , whereas t_{op} is the total annual operating time.

3.2.2 Financial Risk

In mathematical terms, the financial risk associated with a design project can be defined as the probability of not meeting a certain target profit (maximization) or cost (minimization) level referred to as Ω [22, 27]. Hence, the financial risk associated with a design x and a target Ω can be expressed as follows:

$$Risk(x, \Omega) = P[TC(x) \geq \Omega] \quad (17)$$

Here, $TC(x)$ is the actual total cost, that is, the cost resulting after the uncertainty has been unveiled and a scenario realized. The above probability can be expressed in terms of the probability of exceeding the target cost in each individual scenario realization:

$$Risk(x, \Omega) = \sum_s prob_s z_s(x, \Omega) \quad (18)$$

where z_s is a binary variable defined for each scenario, as follows:

$$z_s(x, \Omega) = \begin{cases} 1 & \text{if } TC_s \geq \Omega \\ 0 & \text{otherwise} \end{cases} \quad \forall s$$

As can be observed, for a given design, the probability of exceeding the target cost in each particular scenario is either zero or one. A possible way of avoiding

the use of binary variables when evaluating the financial risk is to utilize the definition of downside risk [46]. The financial risk associated with design x and target total cost (Ω) is given by the area under the probability curve from the target cost = Ω to $+\infty$ as shown in Fig. 3(a). A more straight forward way of assessing the trade-off between risk and total cost is using the cumulative probability associated with a given design x and target level (see Fig. 3(b)). Here, the downside risk is the area enclosed above the cumulative probability curve between the target level and positive infinity. Mathematically, this metric can be determined as follows:

$$DRisk(x, \Omega) = \sum_s prob_s \delta_s(x, \Omega) \quad (19)$$

where $\delta(x, \Omega)$ is a positive variable that measures the deviation from a target Ω , that is:

$$\delta_s(x, \Omega) \geq TC_s - \Omega \quad \forall s \quad (20)$$

Notice that the downside risk is a continuous linear measure that does not require the definition of binary variables. This is a highly desirable property to potentially reduce the computational requirements of the models to manage risk.

3.3 Remarks

- The model presented accounts for the minimization of the expected total annualized cost of the cycle. To calculate the cost associated with a given time horizon, it suffices to multiply the annualized cost with the corresponding number of years. Note that the results of the optimization problem do not depend on the number of periods considered in the study, since the number of years is a constant value and hence can be removed from the objective function without affecting the calculations.
- By performing some algebraic transformations on the economic objective function of the model, it can be shown that minimizing the expected total cost is equivalent to minimizing the cost in the mean scenario, assuming that the same energy consumption is attained in all the scenarios:

$$\begin{aligned} E[TC] &= \sum_s prob_s TC_s \\ &= \sum_s prob_s [CC + (cq_s Q_{k=D} + ce_s W_{k=P}) t_{op}] \\ &= \sum_s prob_s CC + \sum_s prob_s cq_s Q_{k=D} t_{op} + \sum_s prob_s ce_s W_{k=P} t_{op} \quad (21) \\ &= CC \sum_s prob_s + Q_{k=D} t_{op} \sum_s prob_s cq_s + W_{k=P} t_{op} \sum_s prob_s ce_s \\ &= CC + Q_{k=D} t_{op} \bar{c}_q + W_{k=P} t_{op} \bar{c}_e \end{aligned}$$

Here, \bar{c}_q and \bar{c}_e represent the expected values of the energy and electricity cost, respectively. In practice, it is convenient to replace constraint 10 by equation 21 in order to achieve a better numerical performance. Note that this simplification assumes that the operating conditions of the cycle are fixed once the design is decided on (i.e. Q_k is equal in all scenarios).

- As shown in [37], both the financial risk and downside risk can be effectively manipulated by minimizing the worst case (i.e., the total cost in the most unfavorable scenario). The worst case possesses also the desired property of avoiding the definition of auxiliary binary variables.
- The model presented can handle uncertainties in any of the coefficients of the objective function, including the capital cost. This represents an important feature of the proposed approach.
- In those cases in which the uncertain coefficients follow specific types of probability functions (see [47]), it is possible to apply chance constrained programming techniques to perform an analytical integration of the probabilistic constraint defined by Eq. 17.

4 Solution Method

The design task is finally posed as a bi-criteria nonlinear programming (NLP) problem of the following form:

$$\begin{aligned}
 \text{(M)} \quad & \min_x \quad U = \{E[TC], DRisk\} \\
 & \text{s.t.} \quad \text{constraints 1 to 16, 19 to 20}
 \end{aligned} \tag{22}$$

The solution to this problem is given by a set of efficient or Pareto optimal points representing alternative process designs, each achieving a unique combination of economic performance and downside risk. For the calculation of the Pareto set of (M), two main methods exist in the literature. These are the weighted-sum method and the ϵ -constraint method [48]. The weighted-sum method is only rigorous for problems with convex Pareto sets, whereas the epsilon constraint (ϵ -constraint) method is rigorous for both, the convex and non-convex cases. In general, the thermodynamic correlations used to determine the enthalpies in model (M) will add non-convexities in the mathematical formulation. Thus, the ϵ -constraint method is better suited to our problem.

This method is based on formulating an auxiliary model (MA), which is obtained by transferring one of the objectives of the original problem (M) to an additional constraint. This constraint imposes an upper limit on the value of the secondary objective. Model (MA) is then solved for different values of the

auxiliary parameter ϵ in order to generate the entire Pareto set of solutions:

$$\begin{aligned}
 \text{(MA)} \quad & \min_x E[TC] \\
 & \text{s.t.} \quad DRisk(x, \Omega) \leq \epsilon \\
 & \text{constraints 1 to 16, 19 to 20}
 \end{aligned} \tag{23}$$

The extreme points of the search interval of ϵ ($\epsilon \in [\underline{\epsilon}, \bar{\epsilon}]$), can be determined by optimizing each single objective separately.

5 Case Study

The capabilities of our approach are illustrated through a case study that addresses the design of a typical absorption cooling system (see Fig. 1). The system is an absorption cooling cycle driven by low grade heat that utilizes ammonia-water as working pair. The input data of the problem, which includes the cooling capacity of the cycle and the external fluid (water) temperatures, are given in Table 1. A time horizon of 15 years was considered, so the annualized total cost was multiplied by 15 in the calculations. Note that, as commented before, the consideration of a specific time horizon does not affect the output of the optimization model.

The uncertain parameters (i.e., steam and electricity cost) were described through 100 equiprobable scenarios that were generated by performing a Monte Carlo sampling on a set of Gaussian probability functions. Specifically, we considered 5 distributions with mean values 1, 1.5, 2, 2.5 and 3 times larger than the nominal energy cost used in [41]. All these distributions assumed a standard deviation of 30 %. Figs. 4(a) and 4(b) shows the histogram of frequencies associated with the resulting discrete probability distributions that characterize the heat and electricity cost.

6 Results and Discussions

The problem was implemented in the modeling system GAMS [49] interfacing with CONOPT [50] as main optimization package. The resulting optimization problem features 713 continuous variables and 821 constraints. In general, the number of variables and constraints of the model is a function of the number of scenarios considered, and the number of equipment units and streams. The number of scenarios is typically determined by applying a statistical analysis. On the other hand, the number of process units and streams is given by the topology of the absorption cycle.

Note that the global optimality of the solutions found cannot be guaranteed, since we are using a local optimizer. Thus, these solutions must be regarded as locally optimal unless a global optimization method is employed [51]. The application of this last type of techniques, which tend to be highly computationally intensive, is out of the scope of the current work. Hence, we consider that a local solution to the problem is sufficient for the purpose of the analysis performed.

6.1 Pareto optimal set of solutions

The model was first solved by optimizing each single objective separately. In the calculation of the downside risk, the target level Ω was set to $4.5 \times 10^5 \text{€}$. These single-objective optimizations provided the lower and upper limits of the search interval in which the downside risk must fall. This interval was next partitioned into 20 sub-intervals, and the model was then calculated in the limits of each of them. The total computation time was 2.91 seconds on a 1.81 GHz machine.

The Pareto points obtained by following this strategy are shown in Fig. 5. Note that each point in the Pareto set represents a different optimal design operating under a set of specific conditions. Furthermore, each trade-off solution involves a different compromise between expected total cost and risk. As can be observed in the figure, there is a clear trade-off between both objective functions, since a reduction in downside risk can only be achieved at the expense of an increase in the expected total cost.

The points A and B shown in Fig. 5 are the two extreme Pareto optimal designs. In design A, the expected total cost is 1.2 % smaller than in B, whereas in B the downside risk is 6.1 % smaller than in A. It is interesting to notice that in the upper part of the Pareto curve it is possible to achieve a substantial reduction of the downside risk at the expense of a marginal increase of the expected total cost. For example, in solution C, where $DRisk = 12,870 \text{€}$ and $E[TC] = 285,220 \text{€}$ it is possible to decrease the downside risk by 4 % at the expense of increasing the total cost only by 0.21 %. Hence, in view of these results, it seems convenient to select solutions close to cycle A, since they can reduce the risk level without compromising to a large extent the average economic performance of the system.

Furthermore, Fig. 6(a) depicts the capital cost and the expected operating cost of the cycles of the Pareto curve as a function of the downside risk. As can be observed, reducing the downside risk level leads to an increase in the capital cost, since this implies investing in heat exchangers with larger areas. In practice, the reduction of the expected operating cost that is attained by using

bigger equipments does not compensate the extra capital investment required. Hence, the overall effect is that the expected total cost and downside risk tend to be conflictive criteria, as already discussed before. In Fig. 6(b) we show the relationship between the total area of the cycle, the coefficient of performance (COP) and the downside risk level. As can be seen, the minimization of the downside risk leads to cycles with better COPs and larger areas. Note that the reduction in the energy consumption makes the cycle less sensitive to the fluctuations in the price of steam, which is the main parameter affecting the operating cost. This leads to a more robust behavior of the system in the face of uncertainty.

6.2 Cumulative Risk Curves

Fig. 7 shows the cumulative risk curves associated with the extreme Pareto optimal designs. As can be observed, when the risk is reduced, the probability curve “rotates” in such a way that its lower part moves to the left whereas the upper one moves to the right. This is because the probability of highly undesirable scenarios (i.e., scenarios with high total cost) is reduced at the expense of lowering the probability of favorable situations (i.e., with a small total cost). For instance, in the minimum cost solution, the probability of exceeding a high cost level (like for instance 556,500 €), is 8 %, whereas in the least risky one this probability drops to 5 %. On the other hand, the probability of a total cost bellow 186,000 € is 26 % in the minimum cost solution and 21 % in the minimum downside risk one.

Finally, Fig. 8, depicts the total cost associated with each particular scenario realization. As shown in the figure, there are cases in which the minimum cost solution performs better than the minimum downside risk one, and others in which the opposite situation occurs. A more detailed analysis of these results reveals that, as expected, the minimum cost solution is superior when the energy price is low, whereas the other one yields better results when the energy cost increases.

6.3 Sensitivity analysis

Note that the shape of the risk curves, and even the existence of a trade-off between expected cost and risk, will depend on the specific example being solved, and more precisely on the capital and operating cost data. In our example, it turns out that the difference between the curves is not very pronounced. In order to elucidate whether this was a particular feature of our example or not, we ran several case studies that differed in the values of the target level as well as the operating and capital cost parameters.

In first place, we solved the problem considering a risk-taker decision-maker with a preference for a small target level ($\Omega = 2 \times 10^5 \text{ €}$). Fig. 9 shows the obtained results that illustrate how the risk curves of the extreme solutions of the problem tend to approximate when a small value of Ω is chosen. In other words, risk-takers will chose solutions close to the minimum expected cost one.

To study the impact that the operation and capital cost have in the risk curves, we next solved two examples which differed in the operating times and capital cost coefficients. In the first case, we considered an annual operating time of 4,000 h per year in order to increase the weigh of the operating cost in the total cost of the system. The target level for this case was fixed to $\Omega = 1.6 \times 10^6 \text{ €}$. Given this data, the model tries to minimize the operating cost by investing in equipments with larger areas. As a result, the trade-off between expected total cost and downside risk is small, since the areas of the heat exchangers are already large in order to minimize the energy consumption. Consequently, the cumulative risk curves of the extreme solutions are quite close, as depicted in Fig. 10(a).

In the second example we doubled the coefficients of the capital costs and set $\Omega = 5.5 \times 10^5 \text{ €}$. In this case, the optimization model minimizes the capital cost by investing in smaller heat exchangers, since they represent a large percentage of the total cost. As a result, the trade-off between expected cost and downside risk is more pronounced, and the risk curves move away, as shown in Fig.10(b).

As can be observed, in all the cases the probability curves of the extreme solutions are quite close. Hence, in view of these numerical results and in the absence of a more rigorous theoretical analysis, we conclude that the design problem is *per se* quite rigid (i.e., it is difficult to manipulate the risk associated with the investment). This might be attributed to the inherent trade off that naturally exists between the capital and operating cost of an absorption cycle (i.e., to reduce the operating cost it is necessary to invest in larger equipments). In any case, as discussed and shown before, the risk level can still be manipulated to a certain extent by properly varying the areas of the equipments. This is an interesting insight that we get from the stochastic model, which shows how the optimal design of an absorption cycle is not very much affected by the uncertainty in the energy cost, since the potential savings that can be achieved by decreasing the energy consumption are compensated by the required increase in the capital investment. We should note, however, that such a conclusion strongly depends on the input data of the model.

7 Conclusion

This work has presented a systematic approach for the design of absorption cooling cycles under uncertainty in the energy cost. The design task has been formulated as a bi-criteria stochastic NLP model that seeks to minimize the expected total cost and the associated risk. The latter criterion has been measured by the downside risk, which avoids the definition of binary variables thus leading to better numerical performance. The solution to the problem is given by a set of Pareto optimal solutions that trade-off the objectives considered in the analysis. In this work, these solutions have been calculated via the epsilon constraint method.

The capabilities of the proposed modeling framework and solution strategy have been illustrated through the design of a typical absorption cooling system. It has been clearly shown that reductions in the downside risk can be attained by slightly increasing the expected cost of the cycle. This can be achieved by investing in heat exchangers with larger areas, which lowers energy consumption thus making the cycle less sensitive to fluctuations in the energy price.

8 Nomenclature

Abbreviations

A	Absorber
C	Condenser
D	Desorber
E	Evaporator
P	Solution pump
RV	Refrigerant expansion valve
SC	Subcooler
SHX	Solution heat exchanger
SV	Solution expansion valve
yr	Year

Indices

i	Component of a stream
j	Streams
k	Unit

Sets

$IN(k)$	Set of input streams to unit k
$OUT(k)$	Set of out put streams from unit k

Parameters

c_1	Cost parameter $\left[\frac{\text{€}}{m^2} \right]$
c_2	Cost parameter $[\text{€}]$
c_3	Cost parameter $\left[\frac{\text{€}}{kW} \right]$
cq_s	Unitary cost of steam in scenario s $\left[\frac{\text{€}}{MWh} \right]$
ce_s	Unitary cost of electricity in scenario s $\left[\frac{\text{€}}{MWh} \right]$
cr	Capital recovery factor $[-]$
$prob_s$	Probability of total cost of scenario s

ir	Interest rate [-]
t_{op}	Operating hours $\left[\frac{h}{yr}\right]$
U_k	Overall heat transfer coefficient of unit k $\left[\frac{kW}{m^2K}\right]$

Variables

A_k	Area of heat exchanger k [m^2]
CC	Total capital cost [€]
C_{exp}	Cost of the expansion valves [€]
C_{hxs}	Cost of the heat exchangers [€]
CO_s	Total operating cost in scenario s [€]
C_p	Cost of the pump [€]
COP	Coefficient of performance [-]
$DRisk$	Downside risk [€]
$E[TC]$	Expected total cost [€]
ΔT_k^{lm}	Logarithmic mean temperature difference in equipment k [$^{\circ}C$ or K]
ΔT_k^h	Temperature difference in the hot end in equipment k [$^{\circ}C$ or K]
ΔT_k^c	Temperature difference in the cold end in equipment k [$^{\circ}C$ or K]
ΔT	Temperature difference of heat exchangers in equipment k [$^{\circ}C$ or K]
h_j	Enthalpy of stream j $\left[\frac{kJ}{kg}\right]$
m_j	Mass flow rate of stream j $\left[\frac{kg}{s}\right]$
P_j	Pressure of stream j [bar]
P	Probability [-]
Q_k	Heat transferred in unit k [kW]
TC	Total cost [€]
TC_s	Total cost in scenario s [€]
T_j	Temperature of stream j [$^{\circ}C$ or K]
W_p	Mechanical power of the pump [kW]
$x_{i,j}$	Mass fraction of component i in stream j [-]
z_s	Binary variable (1 if the cost in scenario s exceeds the target level, 0 otherwise)

Greek letters

Ω	Target on the total cost [€]
δ	Deviation of TC from Ω [€]
δ_s	Deviation of TC_s from Ω [€]

Acknowledgements

Berhane H. Gebreslassie expresses his gratitude for the financial support received from the University Rovira i Virgili. The authors also wish to acknowledge support of this research work from the Spanish Ministry of Education and Science (projects DPI2008-04099, PHB2008-0090-PC and BFU2008- 863 00196) and the Spanish Ministry of External Affairs (projects A/8502/07, HS2007- 864 0006 and A/020104/08).

References

- [1] Q. G. Lin, G. H. Huang, B. Bass, X. S. Qin. IFTEM: An interval-fuzzy two-stage stochastic optimization model for regional energy systems planning under uncertainty. *Energy Policy*, 37(3):868–878, 2009.
- [2] Y. P. Cai, G. H. Huang, Z. F. Yang, Q. Tan. Identification of optimal strategies for energy management systems planning under multiple uncertainties. *Applied Energy*, 86(4):480–495, 2009.
- [3] J. T. McMullan. Refrigeration and the environment – issues and strategies for the future. *International Journal of Refrigeration*, 25:89–99, 2002.
- [4] K. E. Herold, R. Radermacher, S. A. Klein. *Absorption chillers and heat pumps*. CRC Press, 1996.
- [5] R. D. Misra, P. K. Sahoo, A. Gupta. Thermoeconomic evaluation and optimization of an aqua-ammonia vapour-absorption refrigeration system. *International Journal of Refrigeration*, 29:47–59, 2006.
- [6] Ö. Kizilkan, A. Sencan, S. A. Kalogirou. Thermoeconomic optimization of a li-br absorption refrigeration system. *Chemical Engineering and Processing: Process Intensification*, 46:1376–1384, 2007.
- [7] A. Bejan, G. Tsatsaronis, M. Moran. *Thermal Design & Optimization*. John Wiley & Sons Inc., 1996.
- [8] I.E. Grossmann, J.A. Caballero, H. Yeomans. Mathematical programming approaches for the synthesis of chemical process systems. *Korean J. Chem. Eng.*, 16:407, 1999.
- [9] L. T. Biegler and A. W. Westerberg I. E. Grossmann. *Systematic Methods of Chemical Process Design*. Prentice-Hall PTR, New Jersey, 1997.
- [10] L. M. Chavez-Islas, C. L. Heard, I. E. Grossmann. Synthesis and optimization of an ammonia-water absorption refrigeration cycle considering different types of heat exchangers by application of mixed-integer nonlinear programming. *Industrial & Engineering Chemistry Research*, 48(6):2972–2990, 2009.
- [11] L. M. Chavez-Islas, C. L. Heard. Optimization of a simple ammonia-water absorption refrigeration cycle by application of mixed-integer nonlinear programming. *Industrial & Engineering Chemistry Research*, 48(4):1957–1972, 2009.
- [12] T. Savola, T-M. Tveit, C-J. Fogelholm. A MINLP model including the pressure levels and multiperiods for CHP process optimisation. *Applied Thermal Engineering*, 27(11-12):1857–1867, 2007.
- [13] T. Savola, C-J. Fogelholm. Minlp optimisation model for increased power production in small-scale CHP plants. *Applied Thermal Engineering*, 27(1):89–99, 2007.
- [14] J. Wang, Y. Dai, G. Lin. Parametric analysis and optimization for a combined power and refrigeration cycle. *Applied Energy*, 85(11):1071–1085, 2008.
- [15] G. Q. Zhang, L. Wang, L. Liu, Z. Wang. Thermoeconomic optimization of small size central air conditioner. *Applied Thermal Engineering*,

- 24(4):471–485, 2004.
- [16] Z. Yang, S. G. Zhang, H. B. Zhao. Optimization study of combined refrigeration cycles driven by an engine. *Applied Energy*, 76(4):379–389, 2003.
- [17] L. Ahlby, D. Hodgett, T. Berntsson. Optimization study of the compression absorption cycle. *International Journal of Refrigeration-Revue Internationale Du Froid*, 14(1):16–23, 1991.
- [18] S. W. Wallace, S-E. Fleten, A. Ruszczynski, A. Shapiro. Stochastic programming models in energy. In *Handbooks in Operations Research and Management Science*, 10, 637–677. Elsevier, 2003.
- [19] N. V. Sahinidis. Optimization under uncertainty: state-of-the-art and opportunities. *Computers & Chemical Engineering*, 28(6-7):971–983, 2004.
- [20] M. Sadeghi, H. M. Hosseini. Energy supply planning in iran by using fuzzy linear programming approach (regarding uncertainties of investment costs). *Energy Policy*, 34(9):993–1003, 2006.
- [21] E. Svensson, T. Berntsson. Economy and CO_2 emissions trade-off: A systematic approach for optimizing investments in process integration measures under uncertainty. *Applied Thermal Engineering*, In Press, Corrected Proof, DOI: 10.1016/j.applthermaleng.2009.02.010.
- [22] G. Guillen, F. D. Mele, M. J. Bagajewicz, A. Espuña, L. Puigjaner. Multiobjective supply chain design under uncertainty. *Chemical Engineering Science*, 60(6):1535–1553, 2005.
- [23] S. Subrahmanyam, J. F. Pekny, G. V. Reklaitis. Design of batch chemical plants under market uncertainty. *Industrial & Engineering Chemistry Research*, 33(11):2688–2701, 1994.
- [24] R. Lahdelma, S. Makkonen, P. Salminen. Two ways to handle dependent uncertainties in multi-criteria decision problems. *Omega*, 37(1):79–92, 2009.
- [25] I. N. Durbach, T. J. Stewart. Using expected values to simplify decision making under uncertainty. *Omega*, 37(2):312–330, 2009.
- [26] A. Azaron, K. N. Brown, S. A. Tarim, M. Modarres. A multi-objective stochastic programming approach for supply chain design considering risk. *International Journal of Production Economics*, 116(1):129–138, 2008.
- [27] A. Barbaro, M. J. Bagajewicz. Managing financial risk in planning under uncertainty. *AIChE Journal*, 50(5):963–989, 2004.
- [28] A. Gupta, C. D. Maranas. Managing demand uncertainty in supply chain planning. *Computers & Chemical Engineering*, 27(8-9):1219–1227, 2003.
- [29] G. Mavrotas, H. Demertzis, A. Meintani, D. Diakoulaki. Energy planning in buildings under uncertainty in fuel costs: The case of a hotel unit in greece. *Energy Conversion and Management*, 44(8):1303–1321, 2003.
- [30] R. Yokoyama, K. Ito. Optimal design of energy supply systems based on relative robustness criterion. *Energy Conversion and Management*, 43(4):499–514, 2002.
- [31] S. B. Petkov, C. D. Maranas. Design of multiproduct batch plants un-

- der demand uncertainty with staged capacity expansions. *Computers & Chemical Engineering*, 22(Supplement 1):S789–S792, 1998.
- [32] E. Svensson, T. Berntsson, A.B. Strömberg, M. Patriksson. An optimization methodology for identifying robust process integration investments under uncertainty. *Energy Policy*, 37(2):680–685, 2009.
- [33] H. S. Wellons, G. V. Reklaitis. The design of multiproduct batch plants under uncertainty with staged expansion. *Computers and Chemical Engineering*, 13:115–126, 1989.
- [34] J. Acevedo, E. N. Pistikopoulos. Stochastic optimisation based algorithms for process synthesis under uncertainty. *Computers and Chemical Engineering*, 22:647–671, 1998.
- [35] D. M. Cao, X. G. Yuan. Optimal design of batch plants with uncertain demands considering switch over of operating modes of parallel units. *Industrial and Engineering Chemistry Research*, 41:4616–4625, 2002.
- [36] S. B. Petkov, C. D. Maranas. Multiperiod planning and scheduling of multipurpose batch plants under demand uncertainty. *Industrial and Engineering Chemistry Research*, 36:4864–4881, 1997.
- [37] A. Bonfill, M. Bagajewicz, A. Espuña, L. Puigjaner. Risk management in scheduling of batch plants under uncertain market demand. *Industrial and Engineering Chemistry Research*, 43:741–750, 2004.
- [38] J. Balasubramanian, I. E. Grossmann. Approximation to multistage stochastic optimization in multiperiod batch plant scheduling under demand uncertainty. *Industrial and Engineering Chemistry Research*, 43:3695–3713, 2004.
- [39] F. You, I. E. Grossmann. *Optimal Design and Operational Planning of Responsive Process Supply Chains*. book chapter in *Process System Engineering: Volume 3: Supply Chain Optimization* (Papageorgiou and Georgiadis, editors), Wiley-VCH, Weinheim, 2007.
- [40] R. P. Taylor, B. K. Hodge, C. A. James. Estimating uncertainty in thermal systems analysis and design. *Applied Thermal Engineering*, 19(1):51–73, 1999.
- [41] B. H. Gebreslassie, G. Guillen-Gosalbez, J. Laureano, D. Boer. Design of environmentally conscious absorption cooling systems via multi-objective optimization and life cycle assessment. *Applied Energy*, 86(9):1712–1722, 2009.
- [42] L. Roriz, A. Mortal, L.F. Mendes. Study of a plate heat exchanger desorber with a spray column for a small solar powered absorption machine. *3rd International Conference on Heat Powered Cycles, HPC, Cyprus, 2004*.
- [43] J. Fernández-Seara, J. Sieres. The importance of the ammonia purification process in ammonia-water absorption systems. *Energy Conversion and Management*, 47(13-14):1975–1987, 2006.
- [44] J. Pátek, J. Klomfar. Simple functions for fast calculations of selected thermodynamic properties of the ammonia-water system. *International Journal of Refrigeration*, 18:228–234, 1995.
- [45] M. A. Siddiqui. Economic analyses of absorption systems: Part A—design

- and cost evaluation. *Energy Conversion and Management*, 38:889–904, 1997.
- [46] G. D. Eppen, R. K. Martin, L. Schrage. A scenario approach to capacity planning. *Operations Research*, 37(4):517–527, 1989.
- [47] S. L. Janak, X. Lin, C. A. Floudas. A new robust optimization approach for scheduling under uncertainty: Ii. uncertainty with known probability distribution. *Computers & Chemical Engineering*, 31(3):171–195, 2007.
- [48] M. Ehrgott. *Multicriteria optimization*. Springer, 2000.
- [49] A. Brooke, D. Kendrick, A. Meeraus, R. Raman, R. E. Rosenthal. *GAMS-A User's Guide*. GAMS Development Corporation, Washington, 1998.
- [50] A. Drud. *CONOPT Solver Manual*. ARKI Consulting and Development, Bagsvaerd, Denmark, 1996.
- [51] C. A. Floudas. *Deterministic global optimization: Theory. In Methods and Applications*. Dordrecht, The Netherlands: Kluwer, Academic Publishers, 2000.

List of Figures

1	Ammonia-water absorption cycle.	26
2	A generic unit of the absorption cycle.	26
3	Cumulative risk curve.	27
4	Histograms of frequencies of the energy cost parameters.	27
5	Pareto optimal set.	28
6	Relationship between capital cost, expected operating cost, coefficient of performance, total area of the cycle and DRisk.	29
7	Cumulative risk curves of the extreme solutions for $\Omega = 4.5 \times 10^5 \text{ €}$.	30
8	Scenario realizations of the extreme solutions.	30
9	Cumulative risk curves of the extreme solutions for $\Omega = 2 \times 10^5 \text{ €}$.	31
10	Cumulative risk curves of the extreme solutions for $t_{op} = 4,000$ h and doubled CC .	32

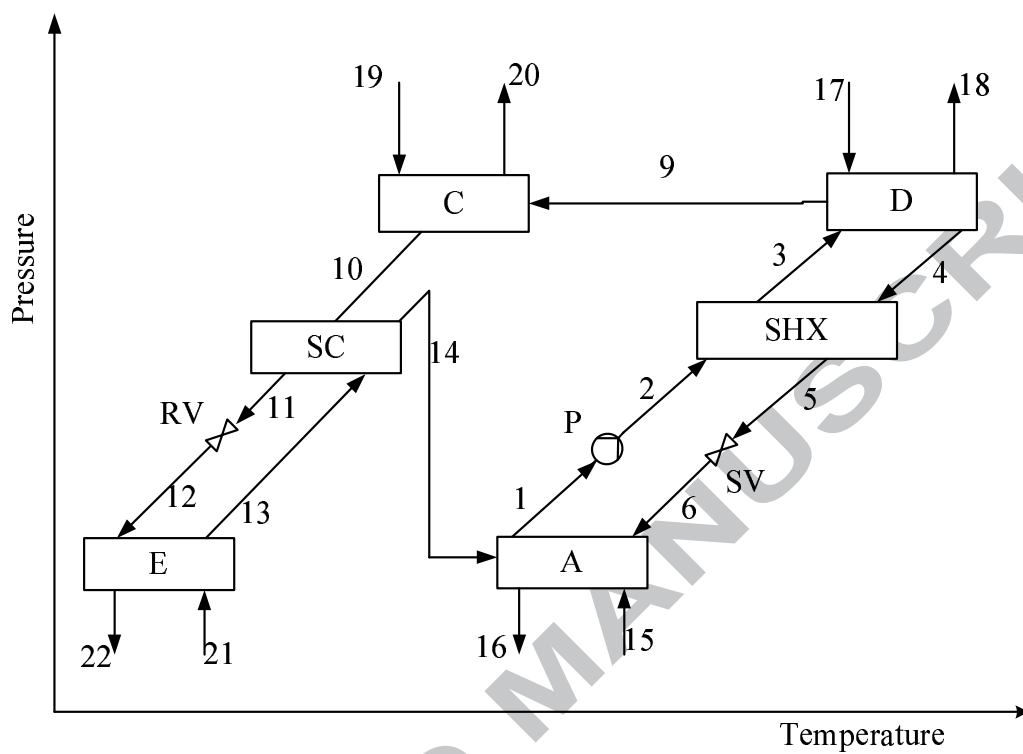

Fig. 1. Ammonia-water absorption cycle.

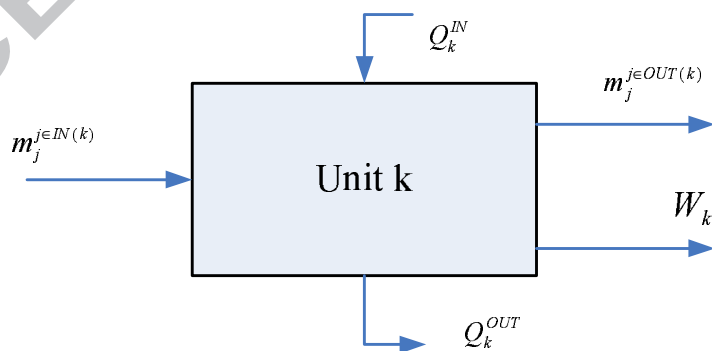

Fig. 2. A generic unit of the absorption cycle.

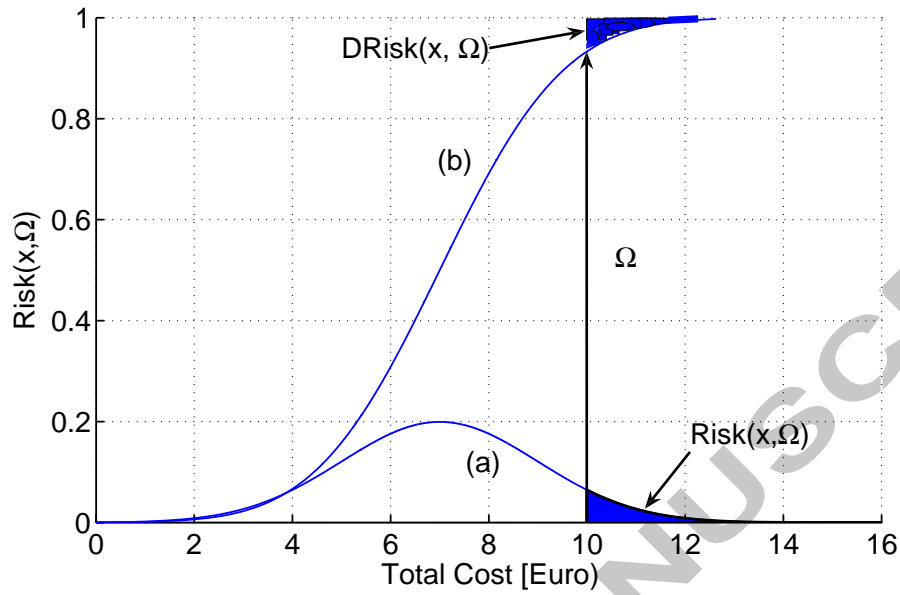

Fig. 3. Cumulative risk curve.

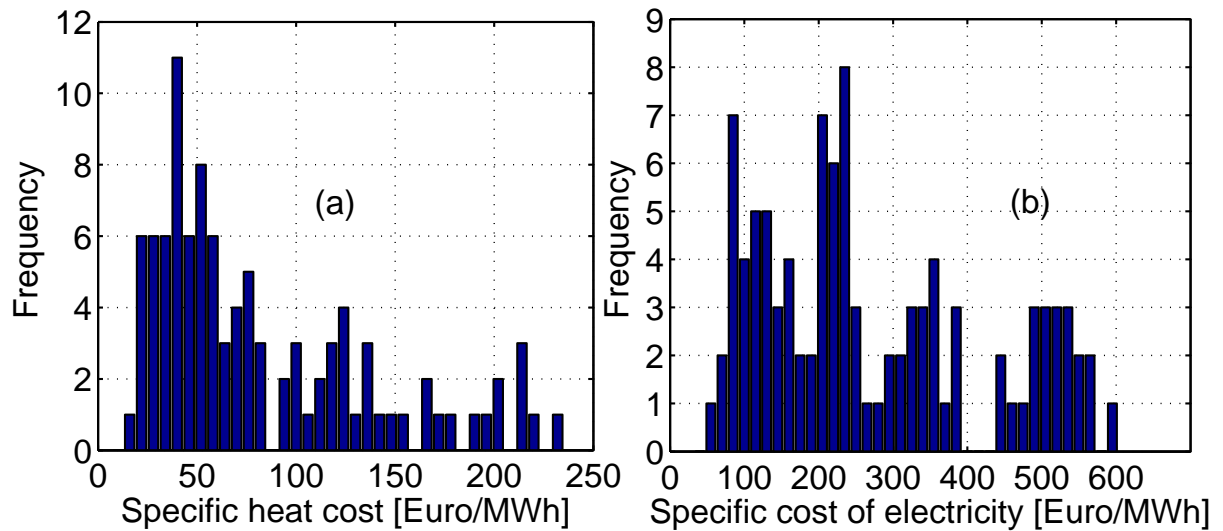

Fig. 4. Histograms of frequencies of the energy cost parameters.

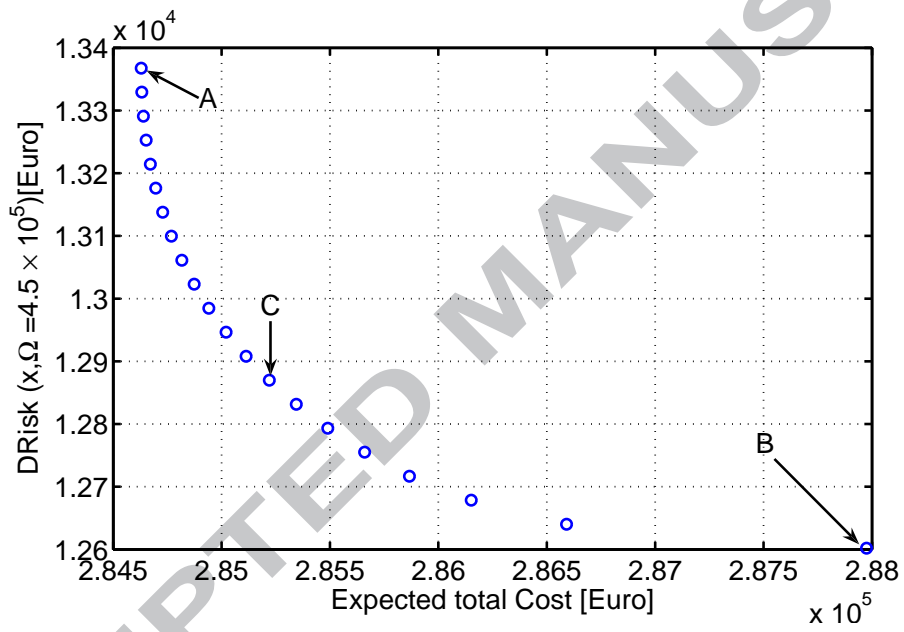
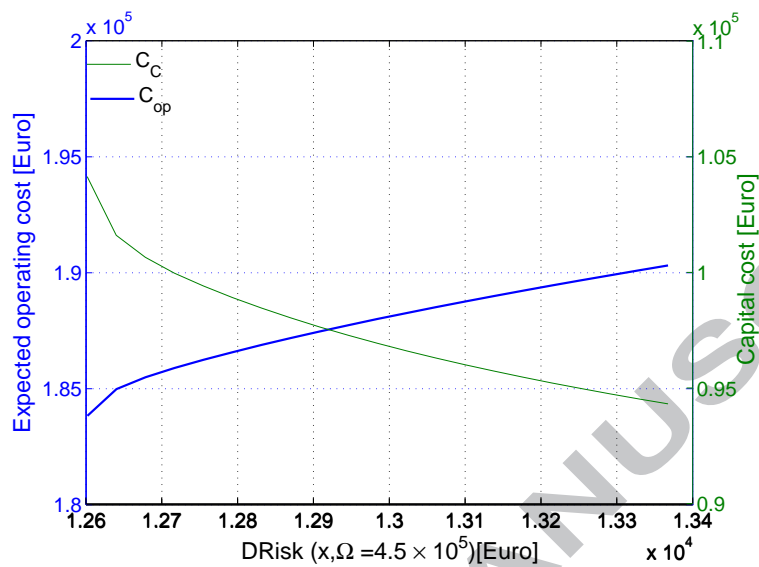
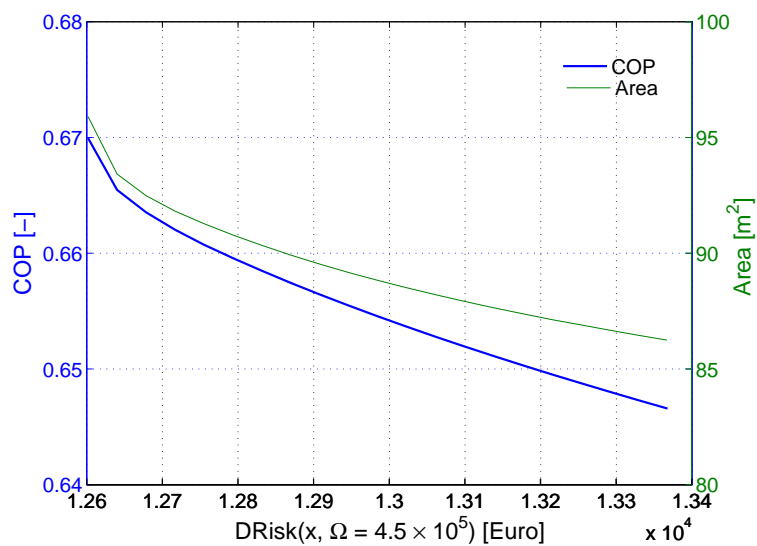

Fig. 5. Pareto optimal set.



(a) Relationship between CC, CO and DRisk.



(b) Relationship between COP, Area and DRisk.

Fig. 6. Relationship between capital cost, expected operating cost, coefficient of performance, total area of the cycle and DRisk.

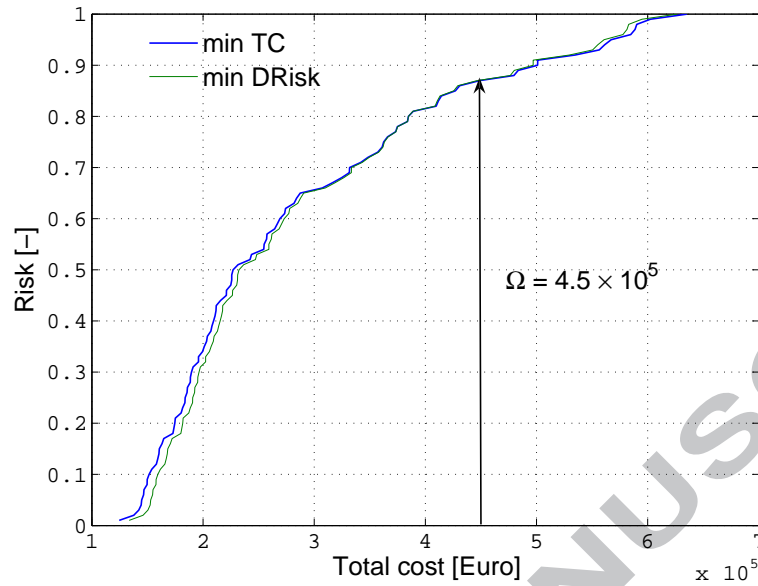

Fig. 7. Cumulative risk curves of the extreme solutions for $\Omega = 4.5 \times 10^5 \text{ €}$.

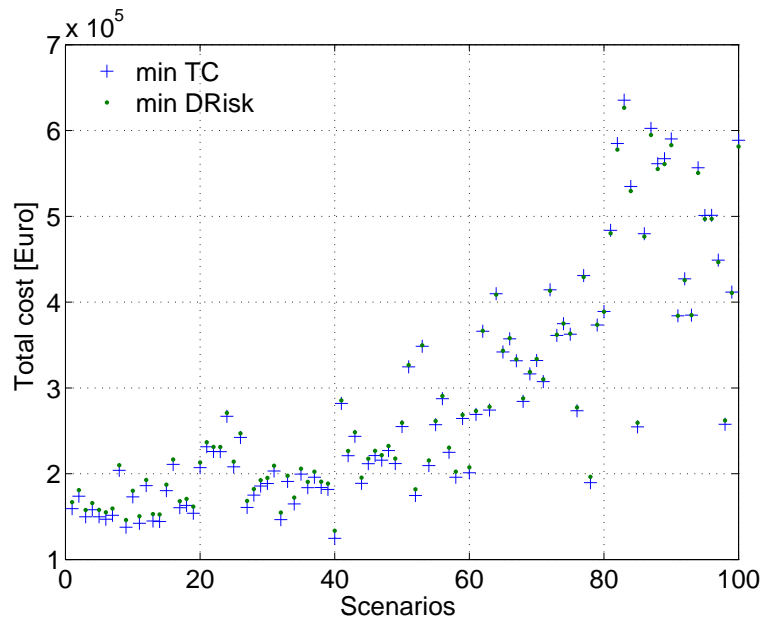

Fig. 8. Scenario realizations of the extreme solutions.

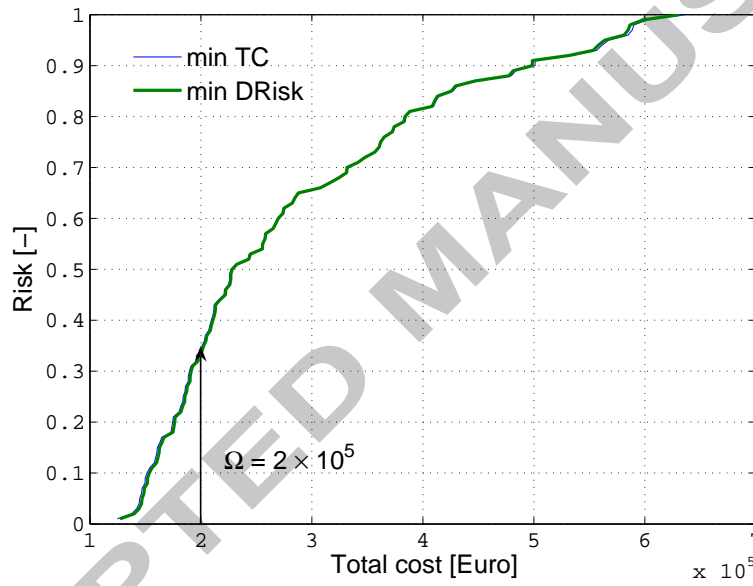
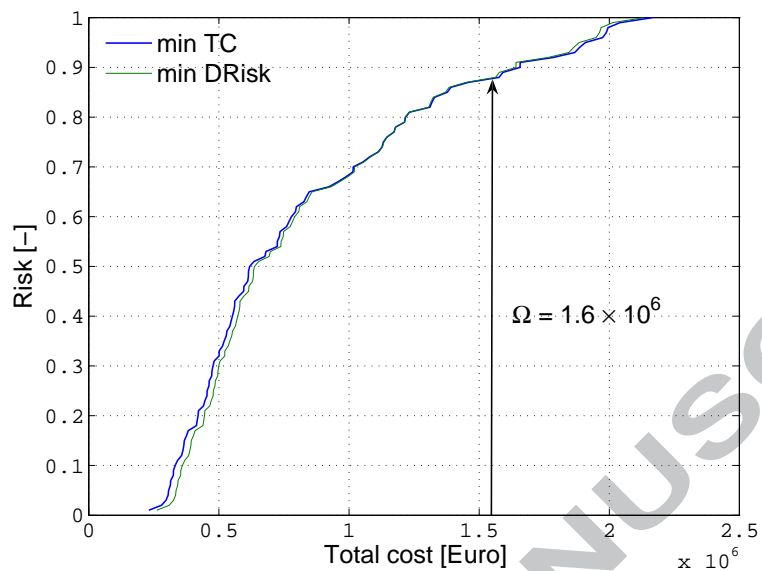
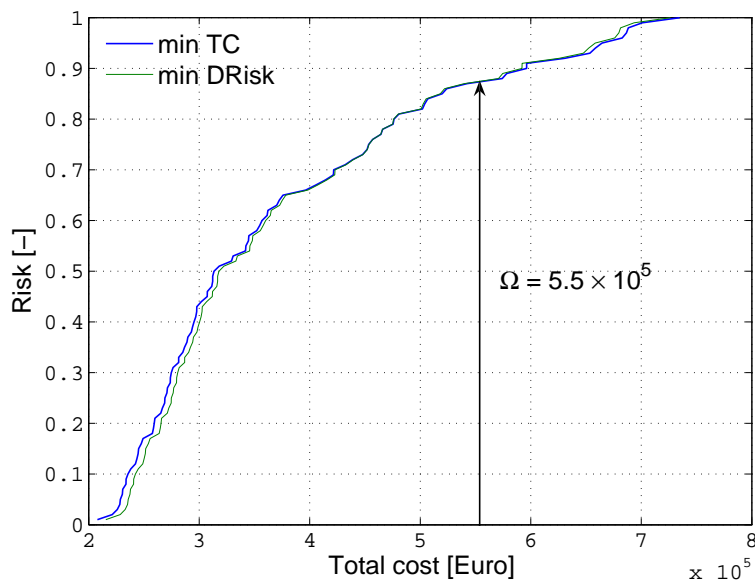

Fig. 9. Cumulative risk curves of the extreme solutions for $\Omega = 2 \times 10^5$ €.



(a) Cumulative risk curves of the extreme solutions for $t_{op} = 4,000$ h



(b) Cumulative risk curves of the extreme solutions for doubled CC .

Fig. 10. Cumulative risk curves of the extreme solutions for $t_{op} = 4,000$ h and doubled CC .

List of Tables

1	Process data of the absorption cooling cycle	34
---	--	----

ACCEPTED MANUSCRIPT

Table 1

Process data of the absorption cooling cycle

Heat transfer coefficients U [$\frac{kW}{m^2K}$] and Temperature data [$^{\circ}C$]	Ref [41]
Desorber heating steam temperature [$^{\circ}C$]	110
Cost data	Ref [41]
Operation time per year [h]	1,000
Other data	Ref [41]
