



**HAL**  
open science

# Limit theorems for splitting trees with structured immigration and applications to biogeography

Mathieu Richard

► **To cite this version:**

Mathieu Richard. Limit theorems for splitting trees with structured immigration and applications to biogeography. *Advances in Applied Probability*, 2011, 43 (1), pp.276-300. hal-00507443

**HAL Id: hal-00507443**

**<https://hal.science/hal-00507443>**

Submitted on 30 Jul 2010

**HAL** is a multi-disciplinary open access archive for the deposit and dissemination of scientific research documents, whether they are published or not. The documents may come from teaching and research institutions in France or abroad, or from public or private research centers.

L'archive ouverte pluridisciplinaire **HAL**, est destinée au dépôt et à la diffusion de documents scientifiques de niveau recherche, publiés ou non, émanant des établissements d'enseignement et de recherche français ou étrangers, des laboratoires publics ou privés.

# LIMIT THEOREMS FOR SPLITTING TREES WITH STRUCTURED IMMIGRATION AND APPLICATIONS TO BIOGEOGRAPHY

MATHIEU RICHARD

ABSTRACT. We consider a branching process with Poissonian immigration where individuals have inheritable types. At rate  $\theta$ , new individuals singly enter the total population and start a new population which evolves like a supercritical, homogeneous, binary Crump-Mode-Jagers process: individuals have i.i.d. lifetimes durations (non necessarily exponential) during which they give birth independently at constant rate  $b$ . First, using spine decomposition, we relax previously known assumptions required for a.s. convergence of total population size. Then, we consider three models of structured populations: either all immigrants have a different type, or types are drawn in a discrete spectrum or in a continuous spectrum. In each model, the vector  $(P_1, P_2, \dots)$  of relative abundances of surviving families converges a.s. In the first model, the limit is the GEM distribution with parameter  $\theta/b$ .

## 1. INTRODUCTION

We want to study and give some properties about several birth-death and immigration models where immigration is structured. All individuals behave independently of the others, their lifetimes are i.i.d. but non-necessarily exponential and each individual gives birth at constant rate  $b$  during her life. We will consider the supercritical case i.e., the mean number of children of an individual is greater than 1. In the absence of immigration, if  $X(t)$  denotes the number of extant individuals at time  $t$ , the process  $(X(t), t \geq 0)$  is a particular case of Crump-Mode-Jagers (or CMJ) processes [12], also called general branching processes. Here,  $X$  is a binary (births arrive singly) and homogeneous (constant birth rate) CMJ process. Now, we assume that at each arrival time of a Poisson process with rate  $\theta$ , a new individual enters the population and starts a new population independently of the previously arrived ones. This immigration model extends to general lifetimes the mainland-island model of S. Karlin and J. McGregor [14]. In that case, the total population process  $X$  is a linear birth-and-death process with immigration. For more properties about this process, see [23] or [26] and references therein. In the context of ecology [4], this model can be used as a null model of species diversity, in the framework of the neutral theory of biodiversity [11].

We first give the asymptotic behavior of the process  $(I(t), t \geq 0)$  representing the total number of extant individuals on the island at time  $t$ . Specifically, there exists  $\eta > 0$  (the Malthusian parameter associated with the branching process  $X$ ) such that  $e^{-\eta t} I(t)$  converges almost surely. S. Tavaré [22] proved this result in the case of a linear birth process with immigration. The case of general CMJ processes was treated by P. Jagers [12] under the hypothesis that the variance of the number of children per individual is finite. We manage to relax this assumption in the case of homogeneous (binary) CMJ-processes thanks to spine

---

2000 *Mathematics Subject Classification.* Primary: 60J80; Secondary: 60G55, 92D25, 60J85, 60F15, 92D40.

*Key words and phrases.* splitting tree, Crump-Mode-Jagers process, spine decomposition, immigration, structured population, GEM distribution, biogeography, almost-sure limit theorem .

decomposition of splitting trees [9, 16, 17] which are the genealogical trees generated by those branching processes. In passing, we obtain technical results on the log-integrability of  $\sup_t e^{-\eta t} X(t)$ .

Then, we consider models where individuals bear clonally inherited types. They intend to model a metacommunity (or mainland) which delivers immigrants to the island as in the theory of island biogeography [19]. However, we made specific assumptions about the spectrum of abundances in the metacommunity. In Model I, there is a discrete spectrum with zero macroscopic relative abundances: when an immigrant enters the population, it is each time of a new type. In Model II, we consider a discrete spectrum with nonzero macroscopic relative abundances: the type of each new immigrant is chosen according to some probability  $(p_i, i \geq 1)$ . In Model III, we consider a continuous spectrum of possible types but to enable a type to be chosen several times from the metacommunity, we change the immigration model: at each immigration time, an individual belonging to a species with abundance in  $(x, x + dx)$  is chosen with probability  $\frac{xf(x)}{\alpha} dx$  (where  $f$  is a positive function representing the abundance density and such that  $\alpha := \int_0^\infty xf(x)dx < \infty$ ) and it starts an immigration process with immigration rate  $x$ . The particular case of abundance density  $f(x) = \frac{e^{-ax}}{x}$  appears in many papers. I. Volkov et al. [24] and G. Watterson [25] consider it as a continuous equivalent of the logarithmic series distribution proposed by R. Fisher et al. [8] as a species abundance distribution. In this particular case, species with small abundances are often drawn but they will have a small immigration rate.

In the three models, we get results for the abundances  $P_1, P_2, \dots$  of different types as time  $t$  goes to infinity: the vector  $(P_1, P_2, \dots)$  rescaled by the total population size converges almost surely. More precisely, in Model I which is an extension of S. Tavaré's result [22] to general lifetimes, we consider the abundances of the surviving families ranked by decreasing ages and the limit follows a *GEM distribution* with parameter  $\theta/b$ . This distribution appears in other contexts: P. Donnelly and S. Tavaré [5] proved that for a sample of size  $n$  whose genealogy is described by a Kingman coalescent with mutation rate  $\theta$ , the frequencies of the oldest, second oldest, etc. alleles converge in distribution as  $n \rightarrow \infty$  to the GEM distribution with parameter  $\theta$ ; S. Ethier [7] showed that it is also the distribution of the frequencies of the alleles ranked by decreasing ages in the stationary infinitely-many-neutral-alleles diffusion model.

In a sense, the surviving families that we consider in our immigration model are "large" families because their abundances are of the same order as the population size. A. Lambert [18] considered "small" families: he gave the joint law of the number of species containing  $k$  individuals,  $k = 1, 2, \dots$

In Section 2, we describe the models we consider and state results we prove in other sections. Section 3 is devoted to proving a result about the process  $X$ , Section 4 to proving a property of the immigration process  $(I(t), t \geq 0)$  while in Section 5, we prove theorems concerning the relative abundances of types in the three models.

## 2. PRELIMINARIES AND STATEMENT OF RESULTS

We first define splitting trees which are random trees satisfying:

- individuals behave independently from one another and have i.i.d. lifetime durations,
- conditional on her birthdate  $\alpha$  and her lifespan  $\zeta$ , each individual reproduces according to a Poisson point process on  $(\alpha, \alpha + \zeta)$  with intensity  $b$ ,
- births arrive singly.

We denote the common distribution of lifespan  $\zeta$  by  $\Lambda(\cdot)/b$  where  $\Lambda$  is a positive measure on  $(0, \infty)$  with mass  $b$  called the *lifespan measure* [17].

The total population process  $(X(t), t \geq 0)$  belongs to a large class of processes called Crump-Mode-Jagers or CMJ processes. In these processes, also called general branching processes [12, ch.6], a typical individual reproduces at ages according to a random point process  $\xi$  on  $[0, \infty)$  (denote by  $\mu := \mathbb{E}[\xi]$  its intensity measure) and it is alive during a random time  $\zeta$ . Then, the CMJ-process is defined as

$$X(t) = \sum_x \mathbf{1}_{\{\alpha_x \leq t < \alpha_x + \zeta_x\}}, \quad t \geq 0$$

where for any individual  $x$ ,  $\alpha_x$  is her birth time and  $\zeta_x$  is her lifespan. In this work, the process  $X$  is a homogeneous (constant birth rate) and binary CMJ-process and we get

$$\mu(dx) = dx \int_{[x, \infty)} \Lambda(dr).$$

We assume that the mean number of children per individual  $m := \int_{(0, \infty)} r \Lambda(dr)$  is greater than 1 (supercritical case).

For  $\lambda \geq 0$ , define  $\psi(\lambda) := \lambda - \int_{(0, \infty)} (1 - e^{-\lambda r}) \Lambda(dr)$ . The function  $\psi$  is convex, differentiable on  $(0, \infty)$ ,  $\psi(0^+) = 0$  and  $\psi'(0^+) = 1 - \int_0^\infty r \Lambda(dr) < 0$ . Then there exists a unique positive real number  $\eta$  such that  $\psi(\eta) = 0$ . It is seen by direct computation that this real number is a *Malthusian parameter* [12, p.10], i.e. it is the finite positive solution of  $\int_0^\infty e^{-\eta r} \mu(dr) = 1$  and is such that  $X(t)$  grows like  $e^{\eta t}$  on the survival event (see forthcoming Proposition 2.1). From now on, we define

$$c := \psi'(\eta).$$

Another branching process appears in splitting trees: if we denote by  $\mathcal{Z}_n$  the number of individuals belonging to generation  $n$  of the tree, then  $(\mathcal{Z}_n, n \geq 0)$  is a Bienaymé-Galton-Watson process started at 1 with offspring generating function

$$f(s) := \int_{(0, \infty)} b^{-1} \Lambda(dr) e^{-br(1-s)} \quad 0 \leq s \leq 1.$$

To get results about splitting trees and CMJ-processes, A. Lambert [16, 17] used tree contour techniques. He proved that the contour process  $Y$  of a splitting tree was a *spectrally positive* (i.e. with no negative jumps) Lévy process whose Laplace exponent is  $\psi$ . Lambert obtained result about the law of the population in a splitting tree alive at time  $t$ . If  $\tilde{\mathbb{P}}_x$  denotes the law of the process  $(X(t), t \geq 0)$  conditioned to start with a single ancestor living  $x$  units of time,

$$(1) \quad \tilde{\mathbb{P}}_x(X(t) = 0) = W(t-x)/W(t)$$

and conditional on being nonzero,  $X(t)$  has a geometric distribution with success probability  $1/W(t)$  i.e. for  $n \in \mathbb{N}^*$ ,

$$(2) \quad \tilde{\mathbb{P}}_x(X(t) = n) = \left(1 - \frac{W(t-x)}{W(t)}\right) \left(1 - \frac{1}{W(t)}\right)^{n-1} \frac{1}{W(t)}$$

where  $W$  is the *scale function* [2, ch.VII] associated with  $Y$ : this is the unique absolutely continuous increasing function  $W : [0, \infty) \rightarrow [0, \infty)$  satisfying

$$(3) \quad \int_0^\infty e^{-\lambda x} W(x) dx = \frac{1}{\psi(\lambda)} \quad \lambda > \eta.$$

The two-sided exit problem can be solved thanks to this scale function:

$$(4) \quad \mathbb{P}(T_0 < T_{(a,+\infty)} | Y_0 = x) = W(a-x)/W(a), \quad 0 < x < a$$

where for a Borel set  $B$  of  $\mathbb{R}$ ,  $T_B = \inf\{t \geq 0, Y_t \in B\}$ .

We now give some properties, including asymptotic behavior, about the CMJ-process  $X$ .

**Proposition 2.1.** *We denote by Ext the event  $\left\{ \lim_{t \rightarrow \infty} X(t) = 0 \right\}$ .*

(i) *We have*

$$(5) \quad \mathbb{P}(\text{Ext}) = 1 - \eta/b$$

*and conditional on Ext<sup>c</sup>,*

$$(6) \quad e^{-\eta t} X(t) \xrightarrow[t \rightarrow \infty]{a.s.} E$$

*where E is an exponential random variable with parameter c.*

(ii) *If, for  $x > 0$ ,  $\log^+ x := \log x \vee 0$ ,*

$$(7) \quad \mathbb{E} \left[ \left( \log^+ \sup_{t \geq 0} (e^{-\eta t} X(t)) \right)^2 \middle| \text{Ext}^c \right] < \infty$$

The proof of the last assertion requires involved arguments using spine decomposition of splitting trees. Proposition 2.1, which will be proved in Section 3, is known in a particular case: if the lifetime  $\Lambda(\cdot)/b$  has an exponential density with parameter  $d$ ,  $(X(t), t \geq 0)$  is a Markovian birth and death process with birth rate  $b$  and death rate  $d < b$ . In that case,  $\eta = b - d$ ,  $c = 1 - d/b = \mathbb{P}(\text{Ext}^c)$  and integrability of  $\sup_{t \geq 0} (e^{-\eta t} X(t))$  stems from Doob's maximal inequality.

We now define the immigration model: let  $\theta$  be a positive number and  $0 = T_0 < T_1 < T_2 < \dots$  be the points of a Poisson process of rate  $\theta$ . At each time  $T_i$ , we assume that a new individual immigrates and starts a new population whose size evolves like  $X$ , independently of the other populations. That is, if for  $i \geq 1$  we call  $(Z^i(t), t \geq 0)$  the  $i$ th oldest family (the family which was started at  $T_i$ ) then  $Z^i(t) = X_i(t - T_i) \mathbf{1}_{\{t \geq T_i\}}$  where  $X_1, X_2, \dots$  are copies of  $X$  and  $(X_i, i \geq 1)$  and  $(T_i, i \geq 1)$  are independent. This immigration model is a generalization of S. Karlin and J. McGregor's model [14] in the case of general lifetimes.

For  $i \geq 1$ , define  $(Z^{(i)}(t), t \geq 0)$  as the  $i$ th oldest family among the surviving populations and  $T^{(i)}$  its birthdate. In particular, by thinning of Poisson point process,  $(T^{(i)}, i \geq 1)$  is a Poisson point process with parameter  $\theta\eta/b$  thanks to (5).

We are now interested in the joint behavior of the surviving families  $(Z^{(i)}(t), t \geq 0)$  for  $i \geq 1$ :

$$\begin{aligned} e^{-\eta t} Z^{(i)}(t) &= e^{-\eta T^{(i)}} e^{-\eta(t-T^{(i)})} Z^{(i)}(t) \\ &\stackrel{(d)}{=} e^{-\eta T^{(i)}} e^{-\eta(t-T^{(i)})} X_{(i)}(t - T^{(i)}) \mathbf{1}_{\{T^{(i)} \leq t\}} \end{aligned}$$

As in (6), denote by  $E_i := \lim_{t \rightarrow \infty} e^{-\eta t} X_{(i)}(t)$  for  $i \geq 1$ . Thus  $E_1, E_2, \dots$  are i.i.d. exponential r.v. with parameter  $c$ . Moreover, the sequences  $(E_i, i \geq 1)$  and  $(T^{(i)}, i \geq 1)$  are independent. It follows that  $e^{-\eta t} Z^{(i)}(t) \rightarrow e^{-\eta T^{(i)}} E_i$  a.s. as  $t \rightarrow \infty$ . We record this in the following

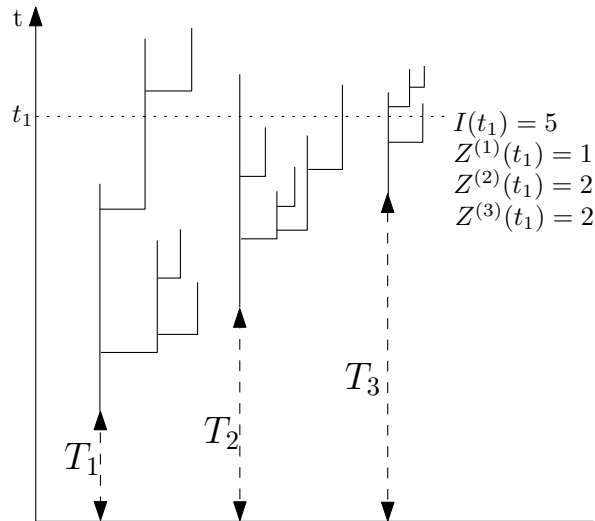

FIGURE 1. splitting trees with immigration. The vertical axis is time, horizontal axis shows filiation. At time  $t_1$ , three populations are extant.

**Proposition 2.2.**

$$e^{-\eta t} (Z^{(1)}(t), Z^{(2)}(t), \dots) \xrightarrow[t \rightarrow \infty]{} (e^{-\eta T^{(1)}} E_1, e^{-\eta T^{(2)}} E_2, \dots) \quad a.s.$$

where the  $E_i$ 's are independent copies of  $E$  and independent of the  $T^{(i)}$ 's.

For  $t \geq 0$ , let  $I(t)$  be the size of the total population at time  $t$

$$I(t) = \sum_{i \geq 1} Z^i(t).$$

The process  $(I(t), t \geq 0)$  is a non-Markovian continuous-time branching process with immigration.

**Theorem 2.3.** (i) For  $t$  positive,  $I(t)$  has a negative binomial distribution with parameters  $1 - W(t)^{-1}$  and  $\theta/b$ . i.e. for  $s \in [0, 1]$ , its generating function is

$$G_t(s) := \mathbb{E} [s^{I(t)}] = \left( \frac{W(t)^{-1}}{1 - s(1 - W(t)^{-1})} \right)^{\theta/b}.$$

(ii) We have

$$I := \lim_{t \rightarrow \infty} e^{-\eta t} I(t) = \sum_{i \geq 1} e^{-\eta T^{(i)}} E_i \quad a.s.$$

and  $I$  has a Gamma distribution  $\Gamma(\theta/b, c)$  i.e the density of  $I$  with respect to Lebesgue measure is

$$g(x) = \frac{c^{\theta/b} x^{\theta/b-1} e^{-cx}}{\Gamma(\theta/b)}, \quad x > 0.$$

The result (i) is a generalization of a result by D.G. Kendall [15] which was the particular Markovian case of a birth, death and immigration process. The proof we give in Section 4 uses equations (1) and (2) about the law of  $X(t)$ .

There exist other proofs of the almost sure convergence in (ii), but they require stronger assumptions. For example, P. Jagers [12] gives a proof for the convergence of general branching processes with immigration under the hypothesis that the variance of the number of children per individual  $\xi(\infty)$  is finite. In our case, this is only true if  $\int_{(0,\infty)} r^2 \Lambda(dr) < \infty$ . In the particular Markovian case described previously, the proof is also easier since  $(e^{-\eta t} X(t), t \geq 0)$  is a non-negative martingale [1, p.111],  $(e^{-\eta t} I(t), t \geq 0)$  is a non-negative submartingale and both converge a.s. In the proof we give in Section 4, the only assumption we use about the measure  $\Lambda$  is that its mass is finite. The proof is based on Proposition 2.1(ii).

In the following, we will consider different kinds of metacommunity where immigrants are chosen and will give results about abundances of surviving populations. In Model I, there is a discrete spectrum with zero macroscopic relative abundances: when a new family is initiated, it is of a type different from those of previous families. The following theorem yields the asymptotic behaviors of the fractions of the surviving subpopulations ranked by decreasing ages in the total population:

**Theorem 2.4** (Model I).

$$\lim_{t \rightarrow \infty} I(t)^{-1} (Z^{(1)}(t), Z^{(2)}(t), \dots) = (P_1, P_2, \dots) \quad a.s.$$

where the law of  $(P_1, P_2, \dots)$  is a GEM distribution with parameter  $\theta/b$ . In other words, for  $i \geq 1$

$$P_i \stackrel{(d)}{=} B_i \prod_{j=1}^{i-1} (1 - B_j)$$

and  $(B_i)_{i \geq 1}$  is a sequence of i.i.d. random variables with law  $\text{Beta}(1, \theta/b)$  whose density with respect to Lebesgue measure is

$$\frac{\theta}{b} (1-x)^{\theta/b-1} \mathbf{1}_{[0,1]}(x).$$

This result was proved by S. Tavaré [22] in the case where  $\Lambda(dr) = \delta_\infty(dr)$  (pure birth process); it is the exponential case defined previously with  $b = 1$  and  $d = 0$ . His result is robust because we see that in our more general case, the limit distribution does not depend on the lifespan distribution but only on the immigration-to-birth ratio  $\theta/b$ . In biogeography, a typical question is to recover data about population dynamics (immigration times, law of lifespan duration) from the observed diversity patterns. In this model, we see that there is a loss of information about the lifespan duration. However, the ratio  $\theta/b$  can be estimated thanks to the species abundance distribution. We will prove Theorem 2.4 in Subsection 5.1.

In Model II, we consider a discrete spectrum with nonzero macroscopic relative abundances. It is close from Model I but now types are given a priori and types of immigrants are independently drawn according to some probability  $p = (p_i, i \geq 1)$ . When a population is initiated (i.e. at each time of the  $\theta$ -Poisson point process), it is of type  $i$  with probability  $p_i > 0$ .

**Theorem 2.5** (Model II). For  $i \geq 1$ , denote by  $I_i(t)$  the number of individuals of type  $i$  at time  $t$  and set  $\alpha_i := \frac{\theta p_i}{b}$ . Then

$$\lim_{t \rightarrow \infty} I(t)^{-1} (I_1(t), I_2(t), \dots) = (P'_1, P'_2, \dots) \quad a.s.$$

where for  $i \geq 1$

$$P'_i \stackrel{(d)}{=} B'_i \prod_{j=1}^{i-1} (1 - B'_j)$$

and  $(B'_i)_{i \geq 1}$  is a sequence of independent random variables such that

$$B'_i \sim \text{Beta} \left( \alpha_i, \frac{\theta}{b} \sum_{j \geq i+1} p_j \right).$$

In particular, for  $i \geq 1$ ,  $P'_i$  has a Beta distribution  $B(\alpha_i, \theta/b - \alpha_i)$ .

The proof of this theorem will be done in Subsection 5.2. In this model, the limit only depend on  $\theta/b$  and the metacommunity spectrum  $(p_i, i \geq 1)$ .

**Remark 2.6.** If the number of possible types  $n$  is finite, then

$$\sum_{i=1}^n P'_i = \sum_{i=1}^n \frac{I_i}{I} = 1, \quad \sum_{i=1}^n \alpha_i = \frac{\theta}{b}$$

and the joint density of  $(P'_1, \dots, P'_n)$  is

$$\frac{\Gamma(\theta/b)}{\prod_{i=1}^n \Gamma(\alpha_i)} \left( \prod_{i=1}^{n-1} x_i^{\alpha_i-1} \mathbf{1}_{\{x_i > 0\}} \right) (1 - x_1 - \dots - x_{n-1})^{\alpha_n-1} \mathbf{1}_{\{x_1 + \dots + x_{n-1} < 1\}}.$$

This is the joint density of a Dirichlet distribution  $\text{Dir}(\alpha_1, \dots, \alpha_n)$ .

In Model III, we consider a continuous spectrum of possible types and we slightly modify the immigration process: when an individual arrives on the island, it starts a new population with an immigration rate proportional to its abundance on the metacommunity. More precisely, let  $\Pi$  be a Poisson point process on  $\mathbb{R}_+ \times \mathbb{R}_+$  with intensity  $dt \otimes xf(x)dx$  where  $f$  is a nonnegative function such that  $\alpha := \int_0^\infty xf(x)dx$  is finite. Then, write  $\Pi := ((T_i, \Delta_i), i \geq 1)$  where  $T_1 < T_2 < \dots$  are the times of a  $\alpha$ -linear Poisson point process and  $(\Delta_i, i \geq 1)$  is a sequence of i.i.d random variables whose density is  $\alpha^{-1}xf(x)dx$  which is independent of  $(T_i, i \geq 1)$ . At time  $T_i$ , a new population starts out and it evolves like the continuous-time branching process with immigration defined for the two previous models with an immigration rate  $\Delta_i$ . The interpretation of this model is as follows: for  $x > 0$ ,  $f(x)$  represents the density of species with abundance  $x$  in the metacommunity and at each immigration time, an individual of a species with abundance in  $(x, x + dx)$  is chosen with probability  $\frac{xf(x)}{\alpha}dx$  proportional to its abundance in the metacommunity.

If  $(Z^i(t), t \geq 0)$  is the  $i$ -th oldest family,

$$Z^i(t) = I_{\Delta_i}^i(t - T_i) \mathbf{1}_{\{t \geq T_i\}}, \quad t \geq 0$$

where the  $I_{\Delta_i}^i$ 's are independent copies of  $I_\Delta$ , which, conditional on  $\Delta$ , evolves like the immigration process of the first two models with an immigration rate  $\Delta$ . According to Theorem 2.3(ii), we know that

$$e^{-\eta t} I_\Delta(t) \xrightarrow[t \rightarrow \infty]{} G \text{ a.s.}$$

where conditional on  $\Delta$ ,  $G \sim \text{Gamma}(\Delta/b, c)$ . We denote by  $F$  its distribution tail

$$F(v) := \mathbb{P}(G \geq v) = \int_0^\infty dx \frac{xf(x)}{\alpha} \int_v^\infty \frac{e^{-ct} t^{x/b-1} c^{x/b}}{\Gamma(x/b)} dt.$$

Hence, we also have



**Proposition 2.7.** For  $i \geq 1$ ,

$$e^{-\eta t} Z^i(t) \xrightarrow[t \rightarrow \infty]{} e^{-\eta T_i} G_i \text{ a.s.}$$

where  $(G_i, i \geq 1)$  is a sequence of i.i.d. r.v. with the same distribution as  $G$  and independent of  $(T_i, i \geq 1)$ .

We again denote by  $I(t)$  the total population at time  $t$ :  $I(t) := \sum_{i \geq 1} Z^i(t)$  and we obtain a result similar to Theorem 2.3 concerning the asymptotic behavior of  $I(t)$ .

**Proposition 2.8.** If  $\int_0^\infty x^2 f(x) dx < \infty$  we have

$$e^{-\eta t} I(t) \xrightarrow[t \rightarrow \infty]{a.s.} \sum_{i \geq 1} e^{-\eta T_i} G_i$$

and the Laplace transform of  $\sigma := \sum_{i \geq 1} e^{-\eta T_i} G_i$  is

$$\mathbb{E}[e^{-s\sigma}] = \exp\left(-\frac{\alpha}{\eta} \int_0^\infty \frac{F(v)}{v} (1 - e^{-sv}) dv\right).$$

Moreover,

$$\mathbb{E}[\sigma] = \frac{1}{\eta bc} \int_0^\infty x^2 f(x) dx < \infty.$$

We also have a result about abundances of different types

**Theorem 2.9** (Model III). We have

$$\left(\frac{Z^1(t)}{I(t)}, \frac{Z^2(t)}{I(t)}, \dots\right) \xrightarrow[t \rightarrow \infty]{} \left(\frac{\sigma_1}{\sigma}, \frac{\sigma_2}{\sigma}, \dots\right) \text{ a.s.}$$

where  $(\sigma_i, i \geq 1)$  are the points of a non-homogeneous Poisson point process on  $(0, \infty)$  with intensity measure  $\frac{\alpha}{\eta} \frac{F(y)}{y} dy$  and  $\sigma = \sum_{i \geq 1} \sigma_i$ .

The proofs of these two results will be done in Subsection 5.3. Notice that in this model, the limit only depends on the lifespan measure via the Malthusian parameter  $\eta$ .

### 3. PROOF OF PROPOSITION 2.1

**3.1. Some useful, technical lemmas.** Thereafter, we state some lemmas that will be useful in subsequent proofs.

**Lemma 3.1.** Let  $Y_1, Y_2, \dots$  be a sequence of i.i.d random variables with finite expectation. Then, if  $S := \sup_{n \geq 1} \left(\frac{1}{n} \sum_{i=1}^n Y_i\right)$ ,

$$\mathbb{E}\left[(\log^+ S)^k\right] < \infty, \quad k \geq 1.$$

*Proof.* According to Kallenberg [13, p.184], for  $r > 0$ ,

$$r\mathbb{P}(S \geq 2r) \leq \mathbb{E}[Y_1; Y_1 \geq r].$$

Hence, choosing  $r = e^s/2$ , we have for  $s \geq 0$ ,

$$\mathbb{P}(\log^+ S \geq s) \leq 2e^{-s}\mathbb{E}[Y_1]$$

and

$$\mathbb{E}[(\log^+ S)^k] = \int_0^\infty k s^{k-1} \mathbb{P}(\log^+ S \geq s) ds \leq 2\mathbb{E}[Y_1] k \int_0^\infty s^{k-1} e^{-s} ds < \infty.$$

This completes the proof.  $\square$

**Lemma 3.2.** *Let  $A$  be a homogeneous Poisson process with parameter  $\rho$ . If  $S := \sup_{t>0}(A_t/t)$ , then for  $a > 0$ ,*

$$\mathbb{P}(S > a) = \frac{\rho}{a} \vee 1.$$

In particular,

$$\forall k \geq 1, \mathbb{E} \left[ (\log^+ S)^k \right] < \infty.$$

*Proof.* If  $a < \rho$ , since  $\lim_{t \rightarrow \infty} A_t/t = \rho$ ,  $\mathbb{P}(S > a) = 1$ . Let now  $a$  be a real number greater than  $\rho$ . Then

$$\mathbb{P}(S \leq a) = \mathbb{P}(\forall t \geq 0, at - A_t \geq 0).$$

According to Bertoin [2, chap.VII], since  $(at - A_t, t > 0)$  is a Lévy process with no positive jumps and with Laplace exponent  $\phi(\lambda) = \lambda a - \rho(1 - e^{-\lambda})$ , we have as in (4)

$$\mathbb{P}(S \leq a) = \frac{H(0)}{H(\infty)}$$

where  $H$  is the scale function associated with  $(at - A_t, t > 0)$ . We compute  $H(0)$  and  $H(\infty)$  using Tauberian theorems [2, p.10]:

- $\phi(\lambda) \underset{0}{\sim} \lambda(a - \rho)$  then  $H(x) \underset{\infty}{\sim} (a - \rho)^{-1}$
- $\phi(\lambda) \underset{\infty}{\sim} \lambda a$  then  $H(x) \underset{0}{\sim} a^{-1}$

Hence,

$$\mathbb{P}(S \leq a) = \frac{a - \rho}{a} = 1 - \frac{\rho}{a}, \quad a > \rho.$$

Then,

$$\begin{aligned} \mathbb{E}[(\log^+ S)^k] &= \int_0^\infty kr^{k-1} \mathbb{P}(\log^+ S \geq r) dr \\ &\leq \int_0^{\log^+ \rho} kr^{k-1} dr + \int_{\log^+ \rho}^\infty kr^{k-1} \frac{\rho}{e^r} dr < \infty \end{aligned}$$

and the proof is completed.  $\square$

**3.2. Proof of Proposition 2.1(i).** A. Lambert proved in [16] that  $\mathbb{P}(\text{Ext}) = 1 - \eta/b$  and in [17] that, conditional on  $\text{Ext}^c$ ,

$$e^{-\eta t} X(t) \xrightarrow[t \rightarrow \infty]{\mathcal{L}} E$$

where  $E$  is an exponential random variable with parameter  $c$ . To obtain a.s. convergence, we use [20, Thm 5.4] where O. Nerman gives sufficient conditions for convergence of CMJ processes to hold almost surely. Here, the two conditions of his theorem are satisfied. Indeed, the second one holds if there exists on  $[0, \infty)$  an integrable, bounded, non-increasing positive function  $h$  such that

$$\mathbb{E} \left[ \sup_{t \geq 0} \left( \frac{e^{-\eta t} \mathbf{1}_{\{t < \zeta\}}}{h(t)} \right) \right] < \infty$$

where we recall that  $\zeta$  is the lifespan duration of a typical individual in the CMJ-process  $X$ . Then, choosing  $h(t) = e^{-\eta t}$ , this condition is trivially satisfied.

The first one holds if there exists a non-increasing Lebesgue integrable positive function  $g$  such that

$$(8) \quad \int_0^\infty \frac{1}{g(t)} e^{-\eta t} \mu(dt) < \infty.$$

Taking  $g(t) = e^{-\beta t}$  with  $\eta > \beta > 0$  and recalling that  $\mu(dt) = \int_{(t, \infty)} \Lambda(dr) dt$ , we have

$$\begin{aligned} \int_0^\infty \frac{1}{g(t)} e^{-\eta t} \mu(dt) &= \int_0^\infty e^{(\beta-\eta)t} \int_t^\infty \Lambda(dr) dt = \int_{(0, \infty)} \Lambda(dr) \int_0^r e^{(\beta-\eta)t} dt \\ &= \int_{(0, \infty)} \frac{1}{\eta - \beta} (1 - e^{(\beta-\eta)r}) \Lambda(dr) \\ &\leq C \int_{(0, \infty)} \Lambda(dr) = Cb < \infty \end{aligned}$$

and condition (8) is fulfilled.

**3.3. Proof of Proposition 2.1(ii).** We want to prove that for the homogeneous CMJ-process  $(X(t), t \geq 0)$ ,

$$\mathbb{E} \left[ \left( \log^+ \sup_{t \geq 0} (e^{-\eta t} X(t)) \right)^2 \middle| \text{Ext}^c \right] < \infty$$

According to Theorem 4.4.1.1 in [16], conditional on non-extinction of  $(X(t), t \geq 0)$ ,

$$X(t) = X_t^\infty + X_t^d + X_t^g$$

where

- $X_t^\infty$  is the number of individuals alive at time  $t$  and whose descendance is infinite. In particular,  $(X_t^\infty, t \geq 0)$  is a Yule process with rate  $\eta$ .
- $X_t^d$  is the number of individuals alive at time  $t$  descending from trees grafted on the right hand side of the Yule tree (right refers to the order of the contour of the planar splitting tree)

$$X_t^d := \sum_{i=1}^{\tilde{N}_t} \tilde{X}_i(t - \tilde{T}_i)$$

where

- $(\tilde{X}_i, i \geq 1)$  is a sequence of i.i.d. splitting trees conditional on extinction and independent of  $X^\infty$ . We know that such trees have the same distribution as subcritical splitting trees with lifespan measure  $\tilde{\Lambda}(dr) = e^{-\eta r} \Lambda(dr)$  (cf. [16]).
- Conditionally on  $(X_t^\infty, t \geq 0)$ ,  $(\tilde{N}_t, t \geq 0)$  is a non-homogeneous Poisson process with mean measure  $(b - \eta) X_t^\infty dt$  and independent of  $(\tilde{X}_i)_i$ . We denote its arrival times by  $\tilde{T}_1, \tilde{T}_2, \dots$
- $X_t^g$  is the number of individuals alive at time  $t$  descending from trees grafted on the left hand side of the Yule tree (left also refers to the contour order).

More specifically, let  $(A, R)$  be a couple of random variables with joint law given by

$$(9) \quad \mathbb{P}(A + R \in dz, R \in dr) = e^{-\eta r} dr \Lambda(dz), \quad 0 < r < z$$

and let  $((A_{i,j}, R_{i,j}), i \geq 0, j \geq 1)$  be i.i.d random variables distributed as  $(A, R)$ . We consider the arrival times

$$T_{i,j} = \tau_i + A_{i,1} + A_{i,2} + \cdots + A_{i,j}, \quad i \geq 0, j \geq 1$$

where  $0 = \tau_0 < \tau_1 < \tau_2 < \cdots$  are the splitting times of the Yule tree, that is, on each new infinite branch, we start a new  $A$ -renewal process independent of the others. We define for  $t \geq 0$ ,

$$X_t^g := \sum_{i,j} \hat{X}_{i,j}(t - T_{i,j}) \mathbf{1}_{\{T_{i,j} \geq t\}}.$$

where  $(\hat{X}_{i,j}, i \geq 0, j \geq 1)$  is a sequence of i.i.d. splitting trees independent of  $X^\infty$ , conditioned on extinction and such that the unique ancestor of  $\hat{X}_{i,j}$  has lifetime  $R_{i,j}$ . We denote by  $\tilde{N}_t := \#\{(i,j), T_{i,j} \leq t\}$  the number of graft times before  $t$ .

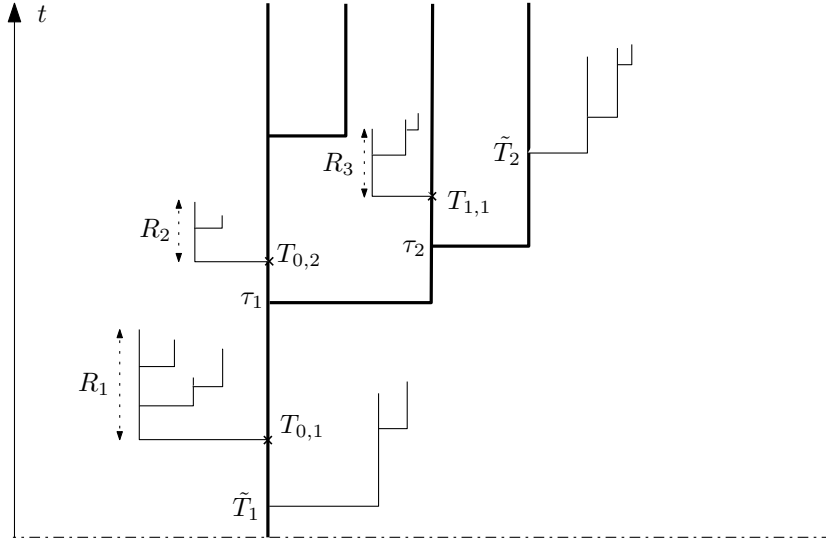

FIGURE 2. Spine decomposition of a splitting tree. In bold, the Yule tree  $X^\infty$  on which we graft on the left (at times  $T_{0,1}, \dots$ ) the trees conditioned on extinction whose ancestors have lifetime durations distributed as  $R$  and on the right (at time  $\tilde{T}_1, \dots$ ) the trees conditioned on extinction.

We will say that a process  $G$  satisfies condition (C) if

$$\mathbb{E} \left[ \left( \log^+ \sup_{t \geq 0} e^{-\eta t} G_t \right)^2 \right] < \infty.$$

Our aim is to prove that  $(X_t, t \geq 0)$  satisfies this condition. To do this, using Minkowski inequality and the inequality

$$\forall x, y \geq 0, \log^+(x + y) \leq \log^+ x + \log^+ y + \log 2,$$

we only have to check that the three processes  $X^\infty, X^g$  and  $X^d$  satisfy (C).

### 3.3.1. Proof of condition (C) for $X^\infty$ .

Since  $(X_t^\infty, t \geq 0)$  is a  $\eta$ -Yule process,  $(e^{-\eta t} X_t^\infty, t \geq 0)$  is a non-negative martingale [1, p.111] and so by Doob's inequality [21],

$$(10) \quad \mathbb{E} \left[ \sup_{t \geq 0} (e^{-\eta t} X_t^\infty)^2 \right] \leq 4 \sup_{t \geq 0} \mathbb{E}[(e^{-\eta t} X_t^\infty)^2]$$

Moreover,  $\mathbb{E}[(X_t^\infty)^2] = 2(e^{2\eta t} - e^{\eta t})$  (again in [1]) and

$$\mathbb{E}[(e^{-\eta t} X_t^\infty)^2] = 2e^{-2\eta t} (e^{2\eta t} - e^{\eta t}) \xrightarrow[t \rightarrow \infty]{} 2.$$

Hence, the supremum in the right hand side of (10) is finite and

$$\mathbb{E} \left[ \left( \sup_{t \geq 0} (e^{-\eta t} X_t^\infty) \right)^2 \right] < \infty.$$

From now on, we will set  $M := \sup_{t \geq 0} e^{-\eta t} X_t^\infty$ . Since  $\mathbb{E}[M^2] < \infty$ , (C) is trivially satisfied by  $X^\infty$ .

### 3.3.2. Proof of condition (C) for $X^d$ .

We recall that

$$X_t^d = \sum_{i=1}^{\tilde{N}_t} \tilde{X}_i(t - \tilde{T}_i).$$

Denote by  $Y_i$  the total progeny of the conditioned splitting tree  $\tilde{X}_i$ , that is, the total number of descendants of the ancestor plus one. Then, a.s for all  $t \geq 0$  and  $i \geq 1$ , we have  $\tilde{X}_i(t - \tilde{T}_i) \leq Y_i$  and

$$X_t^d \leq \sum_{i=1}^{\tilde{N}_t} Y_i \text{ a.s. } t \geq 0.$$

Hence, almost surely for all  $t$ ,

$$e^{-\eta t} X_t^d \leq e^{-\eta t} \sum_{i=1}^{\tilde{N}_t} Y_i = (e^{-\eta t} \tilde{N}_t) \left( \frac{1}{\tilde{N}_t} \sum_{i=1}^{\tilde{N}_t} Y_i \right)$$

and, thanks to Minkowski's inequality,

$$(11) \quad \mathbb{E} \left[ \left( \log^+ \sup_{t \geq 0} (e^{-\eta t} X_t^d) \right)^2 \right]^{1/2} \leq \mathbb{E} \left[ \left( \log^+ \sup_{t \geq 0} (e^{-\eta t} \tilde{N}_t) \right) \right]^{1/2} \\ + \mathbb{E} \left[ \left( \log^+ \sup_{t > 0} \left( \frac{1}{\tilde{N}_t} \sum_{i=1}^{\tilde{N}_t} Y_i \right) \right)^2 \right]^{1/2}$$

We first consider the second term in the right hand side of (11):

$$\mathbb{E} \left[ \left( \log^+ \sup_{t > 0} \left( \frac{1}{\tilde{N}_t} \sum_{i=1}^{\tilde{N}_t} Y_i \right) \right)^2 \right] \leq \mathbb{E} \left[ \left( \log^+ \sup_{n \geq 1} \left( \frac{1}{n} \sum_{i=1}^n Y_i \right) \right)^2 \right]$$

since  $(\tilde{N}_t, t \geq 0)$  is integer-valued. Thanks to Lemma 3.1, this term is finite because  $\mathbb{E}[Y_1]$  is finite. Indeed,  $Y_1$  is the total progeny of a subcritical branching process and it is known [10]

that its mean is finite.

We are now interested in the first term in the r.h.s. of (11). We work conditionally on  $X^\infty =: (f(t), t \geq 0)$ . Since we have  $e^{-\eta t} \int_0^t f(s) ds \leq M$  using the supremum  $M$  of  $(e^{-\eta t} X_t^\infty, t \geq 0)$ ,

$$e^{-\eta t} \tilde{N}_t = e^{-\eta t} \int_0^t f(s) ds \frac{\tilde{N}_t}{\int_0^t f(s) ds} \leq M \frac{\tilde{N}_t}{\int_0^t f(s) ds}$$

Moreover,

$$(\tilde{N}_t, t \geq 0) \stackrel{(d)}{=} (N'_{\int_0^t f(s) ds}, t \geq 0)$$

where  $N'$  is a homogeneous Poisson process with parameter  $b - \eta$ .

Hence, using Minkowski's inequality,

$$\begin{aligned} \mathbb{E} \left[ \left( \log^+ \sup_{t \geq 0} (e^{-\eta t} \tilde{N}_t) \right)^2 \right]^{1/2} &\leq \log^+ M + \mathbb{E} \left[ \left( \log^+ \sup_{t > 0} \left( \frac{N'_{\int_0^t f(s) ds}}{\int_0^t f(s) ds} \right) \right)^2 \right]^{1/2} \\ &= \log^+ M + \mathbb{E} \left[ \left( \log^+ \sup_{t > 0} \left( \frac{N'_t}{t} \right) \right)^2 \right]^{1/2} \end{aligned}$$

and the second term of the r.h.s. is finite using Lemma 3.2.

Hence,  $(\tilde{N}_t, t \geq 0)$  satisfies (C) since  $\mathbb{E}[M^2] < \infty$  and  $X^d$  as well, which ends this paragraph.

### 3.3.3. Proof of condition (C) for $X^g$ .

We have

$$X_t^g = \sum_{i=1}^{\hat{N}_t} \hat{X}_i(t - \hat{T}_i)$$

As in the previous section,

$$e^{-\eta t} X_t^g \leq (e^{-\eta t} \hat{N}_t) \left( \frac{1}{\hat{N}_t} \sum_{i=1}^{\hat{N}_t} \hat{Y}_i \right) \text{ a.s.}$$

where  $\hat{Y}_i$  is the total progeny of the conditioned CMJ-process  $(\hat{X}_i(t), t \geq 0)$ .

Hence,

$$\begin{aligned} \mathbb{E} \left[ \left( \log^+ \sup_{t \geq 0} (e^{-\eta t} X_t^g) \right)^2 \right]^{1/2} &\leq \mathbb{E} \left[ \left( \log^+ \sup_{t \geq 0} (e^{-\eta t} \hat{N}_t) \right)^2 \right]^{1/2} \\ (12) \quad &+ \mathbb{E} \left[ \left( \log^+ \sup_{n > 0} \left( \frac{1}{n} \sum_{i=1}^n \hat{Y}_i \right) \right)^2 \right]^{1/2} \end{aligned}$$

We first prove that the second term in the r.h.s. is finite using Lemma 3.1. We only have to check that  $\mathbb{E}[\hat{Y}_1]$  is finite. We recall that  $\hat{Y}_1$  is the total progeny of a splitting tree whose ancestor has random lifespan  $R_1$  and conditioned on extinction. Conditioning on  $R_1$ , it is also the total progeny of a subcritical Bienaymé-Galton-Watson process starting from a Poisson

random variable with mean  $R_1$ . Hence,  $\mathbb{E}[\hat{Y}_1]$  is finite if  $\mathbb{E}[R_1]$  is finite. As a consequence of (9), we have that  $\mathbb{P}(R_1 \in dr) = e^{-\eta r} \int_r^\infty \Lambda(dz) dr$  and

$$\begin{aligned} \mathbb{E}[R_1] &= \int_{(0,\infty)} \Lambda(dz) \int_0^z r e^{-\eta r} dr \\ &= - \int_{(0,\infty)} \Lambda(dz) \frac{z e^{-\eta z}}{\eta} + \int_{(0,\infty)} \Lambda(dz) \frac{1 - e^{-\eta z}}{\eta^2} \\ &= \frac{\psi'(\eta) - 1}{\eta} + \frac{1}{\eta} = \frac{\psi'(\eta)}{\eta} < \infty. \end{aligned}$$

We are now interested in the first term of the r.h.s. of (12). We need to make calculations on  $\hat{N}_t$  which is the total number of times of graftings  $T_{i,j}$  less than or equal to  $t$ . Recall that for  $i \geq 0, j \geq 1$ ,  $T_{i,j} = \tau_i + \bar{A}_{i,j}$  where  $\bar{A}_{i,j} := A_{i,1} + \dots + A_{i,j}$  and that  $\tau_i$  is the birth time of individual  $i$  and that  $\hat{N}_t$  is the sum of the numbers of graftings before  $t$  on each of the  $X_t^\infty$  branches. For  $i \geq 0$ , denote by  $\alpha_1^i, \alpha_2^i, \dots$ , the birth times of the daughters of individual  $i$  and  $\alpha_0^i = \tau_i$ . For  $k \geq 1$ , denote by  $\tilde{\tau}_k^i := \alpha_k^i - \alpha_{k-1}^i$  the interbirth times. In particular,  $(\tilde{\tau}_k^i, i \geq 0, k \geq 1)$  are i.i.d. exponential r.v. with parameter  $\eta$  since we consider a  $\eta$ -Yule tree.

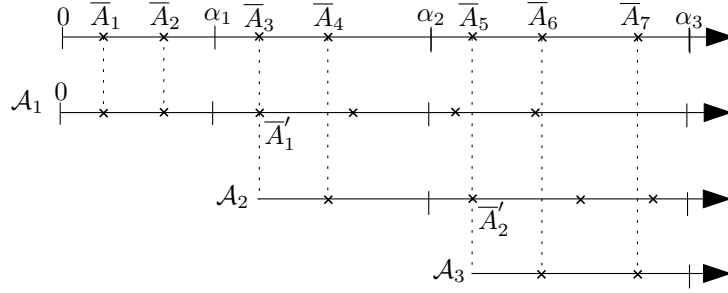

FIGURE 3. Construction of the renewal process  $(\bar{A}_j, j \geq 1)$  by concatenation of the renewal processes  $\mathcal{A}_k$ .

We enlarge the probability space by redefining the renewal processes  $(\bar{A}_{i,j}, j \geq 1)$  from a doubly indexed sequence of i.i.d.  $A$ -renewal processes  $(\mathcal{A}_{i,k}, i \geq 0, k \geq 1)$ . We define the process  $(\bar{A}_{i,j}, j \geq 1)$  recursively by concatenation of the  $\mathcal{A}_{i,k}$ 's as in Figure 3. To simplify notation, we only define  $(\bar{A}_{0,j}, j \geq 1)$  which will be denoted by  $(\bar{A}_j, j \geq 1)$ . Then,

$$\bar{A}'_1 := \inf\{t > \alpha_1 | \mathcal{A}_1 \cap [t, +\infty) \neq \emptyset\}, \quad C_1 := \#\mathcal{A}_1 \cap [0, \alpha_1] + 1,$$

and

$$\bar{A}_j := \inf\{t \geq 0 | \#\mathcal{A}_1 \cap [0, t] = j\}, \quad j = 1, \dots, C_1 + 1.$$

Moreover, for  $l \geq 1$ , if one knows  $C_l$  and  $\bar{A}'_l$ , let  $r_l$  be the unique integer such that  $\bar{A}'_l$  belongs to  $] \alpha_{r_l}, \alpha_{r_l+1} ]$  and define

$$\begin{aligned} \bar{A}'_{l+1} &:= \bar{A}'_l + \inf\{t > \alpha_{r_l+1} - \bar{A}'_l | \mathcal{A}_{r_l+1} \cap [t, +\infty) \neq \emptyset\}, \\ C_{l+1} &:= \#\mathcal{A}_{r_l+1} \cap [0, \alpha_{r_l+1} - \bar{A}'_l] + 1, \end{aligned}$$

and

$$\bar{A}_{C_1+\dots+C_{l+j}} := \bar{A}'_l + \inf\{t \geq 0 \mid \#\mathcal{A}_{r_{l+1}} \cap [0, t] = j\}, \quad j = 1, \dots, C_{l+1}.$$

Then,  $(\bar{A}_j, j \geq 1)$  is a  $A$ -renewal process because we concatenated the independent renewal processes  $(\mathcal{A}_k)$  stopped at the first renewal time after a given time. Indeed, one can see a renewal process as the range of a compound Poisson process whose jumps are distributed as  $A_1$ . The renewal process stopped at the first point after  $t$  is then the range of a compound Poisson process stopped at the first hitting time  $T$  of  $[t, \infty)$ , which is a stopping time. Then  $(\bar{A}_j, j \geq 1)$ , as the range of the concatenation of independent compound Poisson processes killed at stopping times, is a compound Poisson process, by the strong Markov property. In conclusion,  $(\bar{A}_j, j \geq 1)$  is a  $A$ -renewal process.

According to previous computations, we have

$$\hat{N}_t \leq \sum_{i \geq 0, l \geq 1} C_l^i \mathbf{1}_{\{\alpha_{r_{l,i}}^i \leq t\}}$$

where  $C_l^i$  and  $r_{l,i}^i$  are the analogous notations as  $C_l$  and  $r_l$  for individual  $i$ . Then if

$$D_k^i := \#\mathcal{A}_{i,k} \cap [0, \tilde{\tau}_k^i] + 1 \quad k \geq 1, i \geq 0,$$

since  $\alpha_{r_{l,i+1}}^i - \bar{A}'_{l,i} \leq \alpha_{r_{l,i+1}}^i - \alpha_{r_{l,i}}^i = \tilde{\tau}_{r_{l,i}}^i$ , then  $C_l^i \leq D_{r_{l,i}}^i$  and

$$(13) \quad \hat{N}_t \leq \sum_{i \geq 0, l \geq 1} D_{r_{l,i}}^i \mathbf{1}_{\{\alpha_{r_{l,i}}^i \leq t\}} \leq \sum_{i \geq 0, k \geq 1} D_k^i \mathbf{1}_{\{\alpha_k^i \leq t\}} \text{ a.s.}$$

Moreover, the random variables  $(D_k^i, i \geq 0, k \geq 1)$  are independent and identically distributed as 1 plus the value of a  $A$ -renewal process at an independent exponential time  $E$  with parameter  $\eta$

$$D := \sup\{j \geq 1, A_1 + \dots + A_j \leq E\} + 1.$$

The sum of the r.h.s. of (13) has  $2X_t^\infty - 1$  terms. Indeed, each individual of the Yule tree contributes to  $1 + n_i$  terms in the sum where  $n_i$  is the number of daughters of individual  $i$

born before  $t$ . Then, there is  $X_t^\infty + \sum_{i=0}^{X_t^\infty - 1} n_i$  terms in the sum and  $\sum_i n_i$  is the number of descendants of the individual 0 born before  $t$  which equals  $X_t^\infty - 1$ .

Hence, using Minkowski's inequality,

$$(14) \quad \mathbb{E} \left[ \left( \log^+ \sup_{t \geq 0} \left( e^{-\eta t} \hat{N}_t \right) \right)^2 \right]^{1/2} \leq \mathbb{E} \left[ \left( \log^+ \sup_{t \geq 0} \left( e^{-\eta t} (2X_t^\infty - 1) \right) \right)^2 \right]^{1/2} \\ + \mathbb{E} \left[ \left( \log^+ \sup_{n > 0} \left( \frac{1}{n} \sum_{i=1}^n D_i \right) \right)^2 \right]^{1/2}$$

where  $(D_i, i \geq 1)$  are i.i.d. r.v. distributed as  $D$ . The first term of (14) is smaller than  $\mathbb{E}[(\log^+(2M))^2]^{1/2}$  and the second term is finite by another use of Lemma 3.1 if  $\mathbb{E}[D_1] < \infty$ . Denote by  $(C_t, t \geq 0)$  the renewal process whose arrival times are distributed as  $A$ . A little calculation from (9) gives us that  $\mathbb{E}[A] = \frac{m-1}{\eta} > 0$ . Thus, according to Theorem 2.3 of Chapter 5 in [6], we have

$$\lim_{t \rightarrow \infty} \frac{\mathbb{E}[C_t]}{t} = \frac{\eta}{m-1}$$



and so there exists  $\kappa > 0$  such that  $\mathbb{E}[C_t] \leq \kappa t$  for  $t \geq 0$ . Then,

$$\mathbb{E}[D_1] = 1 + \mathbb{E}[C_E] = 1 + \int_0^\infty \eta e^{-\eta t} dt \mathbb{E}[C_t] \leq 1 + \kappa \int_0^\infty \eta e^{-\eta t} dt = 1 + \frac{\kappa}{\eta} < \infty.$$

Finally, the r.h.s. of (14) and (12) are finite and  $X^g$  satisfies condition (C).

#### 4. PROOF OF THEOREM 2.3

**4.1. Some preliminary lemmas.** We start with some properties about  $W$  the scale function associated with  $\psi$  and defined by (3).

**Lemma 4.1.** (i)  $W(0) = 1$ ,  
(ii)  $e^{-\eta t} W(t) \rightarrow c^{-1}$  as  $t \rightarrow \infty$ ,  
(iii)  $W$  is differentiable and  $W \star \Lambda = bW - W'$  where  $\star$  is convolution product.

*Proof.* (i) We have

$$\int_0^\infty e^{-\lambda t} W(t) dt = \frac{1}{\psi(\lambda)} \underset{\lambda \rightarrow \infty}{\sim} \frac{1}{\lambda}$$

because  $\psi(\lambda) = \lambda - b + \int_{(0, \infty)} e^{-\lambda r} \Lambda(dr)$ . Then, by a Tauberian theorem [2, p10],  $\lim_{t \rightarrow 0} W(t) = 1$ .

(ii) (From [17]) For  $\lambda > 0$ , using a Taylor expansion and  $\psi(\eta) = 0$ ,

$$\psi(\lambda + \eta) \underset{\lambda \rightarrow 0}{\sim} \lambda \psi'(\eta) = \lambda c.$$

Then

$$\int_0^\infty W(t) e^{-\eta t} e^{-\lambda t} dt \underset{\lambda \rightarrow 0}{\sim} \frac{1}{\lambda c}$$

and another Tauberian theorem entails that  $W(t) e^{-\eta t}$  converges to  $1/c$  as  $t \rightarrow \infty$ .

(iii) We first compute the Laplace transform of  $W \star \Lambda$ . Let  $\lambda > \eta$

$$\begin{aligned} \int_0^\infty e^{-\lambda t} W \star \Lambda(t) dt &= \int_0^\infty e^{-\lambda t} W(t) dt \int_{(0, \infty)} e^{-\lambda r} \Lambda(dr) \\ &= \frac{1}{\psi(\lambda)} (\psi(\lambda) - \lambda + b) \end{aligned}$$

Integrating by parts and using (i) and (ii),

$$\int_0^\infty e^{-\lambda t} W'(t) dt = \left[ e^{-\lambda t} W(t) \right]_0^\infty + \lambda \int_0^\infty e^{-\lambda t} W(t) dt = -1 + \frac{\lambda}{\psi(\lambda)}$$

and so the Laplace transform of  $bW - W'$  is  $b/\psi(\lambda) + 1 - \lambda/\psi(\lambda)$  which equals that of  $W \star \Lambda$ . This completes the proof.  $\square$

The following lemma deals with the convergence of random series:

**Lemma 4.2.** Let  $(\zeta_i, i \geq 1)$  be a sequence of i.i.d. positive random variables such that  $\mathbb{E}[\log^+ \zeta_1]$  is finite and let  $(\tau_i, i \geq 1)$  be the arrival times of a Poisson point process with parameter  $\epsilon$  independent of  $(\zeta_i, i \geq 1)$ . Then for any  $r > 0$ , the series  $\sum_{i \geq 1} e^{-r\tau_i} \zeta_i$  converges a.s.

*Proof.* We have

$$(15) \quad \sum_{i \geq 1} e^{-r\tau_i} \zeta_i \leq \sum_{i \geq 1} \exp \left( -i \left[ r \frac{\tau_i}{i} - \frac{\log^+ \zeta_i}{i} \right] \right)$$

We use the following consequence of Borel-Cantelli's lemma: if  $\xi_1, \xi_2, \dots$  are i.i.d. non-negative random variables,

$$\limsup_{n \rightarrow \infty} \frac{\xi_n}{n} = 0 \text{ or } \infty \text{ a.s.}$$

according to whether  $\mathbb{E}[\xi_1]$  is finite or not. We use it with  $\xi_i = \log^+ \zeta_i$ . Hence, since  $\mathbb{E}[\log^+ \zeta_1]$  is finite,  $\lim_{i \rightarrow \infty} \log^+ \zeta_i / i = 0$  a.s. Moreover, by the strong law of large numbers,  $\tau_i / i$  converges almost surely to  $1/\epsilon$  as  $i$  goes to infinity. Then,

$$r \frac{\tau_i}{i} - \frac{\log^+ \zeta_i}{i} \xrightarrow{i \rightarrow \infty} \frac{r}{\epsilon} > 0 \text{ a.s.}$$

So the series in (15) converges a.s. □

**4.2. Proof of Theorem 2.3(i).** In order to find the law of  $I(t)$  the total population at time  $t$ , we use the fact that it is the sum of a Poissonian number of population sizes. More specifically, if we denote by  $N_t$  the number of populations at time  $t$ ,  $(N_t, t \geq 0)$  is a Poisson process with parameter  $\theta$  and conditionally on  $\{N_t = k\}$ , the  $k$ -tuple  $(T_1, \dots, T_k)$  has the same distribution as  $(U_{(1)}, \dots, U_{(k)})$  which is the reordered  $k$ -tuple of  $k$  independent uniform random variables on  $[0, t]$ . Hence, conditionally on  $\{N_t = k\}$ ,

$$I(t) \stackrel{(d)}{=} \sum_{i=1}^k X_i(t - U_{(i)}) \stackrel{(d)}{=} \sum_{i=1}^k X_i(t - U_i) \stackrel{(d)}{=} \sum_{i=1}^k X_i(U_i)$$

since all  $U_{(i)}$ 's appear in the sum and the  $U_i$ 's are independent from the  $X_i$ 's. Hence, conditionally on  $\{N_t = k\}$ ,  $I(t)$  has the same distribution as a sum of  $k$  i.i.d. r.v. with law  $X(U)$ . Then,

$$(16) \quad \begin{aligned} G_t(s) &= \sum_{k \geq 0} \mathbb{E} \left[ s^{I(t)} \mid N_t = k \right] \mathbb{P}(N_t = k) \\ &= \sum_{k \geq 0} \mathbb{E} \left[ s^{X_1(U_1)} \right]^k \frac{(t\theta)^k}{k!} e^{-\theta t} \\ &= e^{-\theta t} \exp \left( t\theta \mathbb{E} \left[ s^{X_1(U_1)} \right] \right) \end{aligned}$$

We now compute the law of  $X(t)$  for  $t > 0$  and then we will compute the law of  $X_1(U_1)$ . Using (1), (2) and Lemma 4.1(iii), we have

$$\begin{aligned} \mathbb{P}(X(t) = 0) &= \int_{(0, \infty)} \tilde{\mathbb{P}}_r(X(t) = 0) \frac{\Lambda(dr)}{b} = \int_{(0, \infty)} \frac{W(t-x)}{W(t)} \frac{\Lambda(dr)}{b} \\ &= \frac{1}{bW(t)} W \star \Lambda(t) = 1 - \frac{W'(t)}{bW(t)} \end{aligned}$$

and for  $n \in \mathbb{N}^*$ ,

$$\begin{aligned} \mathbb{P}(X(t) = n) &= \int_{(0, \infty)} \tilde{\mathbb{P}}_r(X(t) = n) \frac{\Lambda(dr)}{b} \\ &= \frac{1}{bW(t)} \left(1 - \frac{1}{W(t)}\right)^{n-1} \left(b - W(t)^{-1}W \star \Lambda(t)\right) \\ &= \left(1 - \frac{1}{W(t)}\right)^{n-1} \frac{W'(t)}{bW(t)^2}. \end{aligned}$$

We now compute  $\mathbb{P}(X_1(U_1) = n)$

$$\begin{aligned} \mathbb{P}(X_1(U_1) = 0) &= \frac{1}{t} \int_0^t \mathbb{P}(X_1(u) = 0) du = 1 - \frac{1}{tb} \int_0^t \frac{W'(u)}{W(u)} du \\ &= 1 - \frac{\log W(t)}{tb} \end{aligned}$$

because  $W(0) = 1$ . For  $n > 0$ ,

$$\begin{aligned} \mathbb{P}(X_1(U_1) = n) &= \frac{1}{t} \int_0^t \mathbb{P}(X_1(u) = n) du = \frac{1}{t} \int_0^t \left(1 - \frac{1}{W(u)}\right)^{n-1} \frac{W'(u)}{bW(u)^2} du \\ &= \frac{1}{bt} \int_{W(t)^{-1}}^1 \frac{(1-u)^{n-1}}{n} du = \frac{(1 - 1/W(t))^n}{bnt}. \end{aligned}$$

We are now able to compute the generating function of  $X_1(U_1)$ . For  $s, t > 0$ ,

$$\begin{aligned} \mathbb{E} \left[ s^{X_1(U_1)} \right] &= \frac{1}{bt} \sum_{n \geq 1} \frac{s^n}{n} \left(1 - \frac{1}{W(t)}\right)^n + 1 - \frac{\log W(t)}{tb} \\ &= 1 - \frac{1}{bt} \left[ \log \left(1 - s(1 - 1/W(t))\right) + \log W(t) \right] \\ &= 1 - \frac{1}{bt} \log \left( W(t) + s(1 - W(t)) \right). \end{aligned}$$

Finally for  $t, s > 0$ , according to (16),

$$G_t(s) = e^{-\theta t} \exp \left( t \theta \mathbb{E} \left[ s^{X_1(U_1)} \right] \right) = (W(t) + s(1 - W(t)))^{-\theta/b}.$$

which is the p.g.f. of a negative binomial distribution with parameters  $1 - W(t)^{-1}$  and  $\theta/b$ .

**4.3. Proof of Theorem 2.3(ii).** We first prove the almost sure convergence. Splitting  $I(t)$  between the surviving and the non-surviving populations, we have

$$(17) \quad e^{-\eta t} I(t) = \sum_{i \geq 1} e^{-\eta t} Z^{(i)}(t) + \sum_{i \geq 1} e^{-\eta t} X_i(t - T_i) \mathbf{1}_{\{t \geq T_i\} \cap \text{Ext}_i}$$

where for  $i \geq 1$ ,  $\text{Ext}_i$  denotes the extinction of the process  $X_i$ . We will show that for each of these two terms, we can exchange summation and limit, so that in particular, the second term vanishes as  $t \rightarrow \infty$ .

We first treat the second term of the r.h.s. of (17). We have

$$C_t := \sum_{i \geq 1} X_i(t - T_i) \mathbf{1}_{\{t \geq T_i\} \cap \text{Ext}_i} \leq \sum_{i \geq 1} \mathbf{1}_{\{t \geq T_i\}} Y_i \mathbf{1}_{\text{Ext}_i} \text{ a.s.}$$

where  $Y_i$  is the total progeny of the  $i$ -th population which does not survive. Moreover,  $\mathbb{E}[Y_1 \mathbf{1}_{\text{Ext}_1}] \leq \mathbb{E}[Y_1]$ ,  $Y_1$  is the total progeny of a subcritical Bienaymé-Galton-Watson process so its mean is finite. Hence, since the r.h.s. in the previous equation is a compound Poisson process with finite mean, it grows linearly and  $e^{-\eta t} C_t$  vanishes as  $t \rightarrow \infty$ .

To exchange summation and limit in the first term of the r.h.s. of (17), we will use the dominated convergence theorem. By Proposition 2.2, we already know that  $e^{-\eta t} Z^{(i)}(t)$  a.s. converges as  $t$  goes to infinity to  $e^{-\eta T^{(i)}} E_i$ . Hence, it is sufficient to prove that

$$(18) \quad \sum_{i \geq 1} \sup_{t \geq 0} \left( e^{-\eta t} Z^{(i)}(t) \right) < \infty \text{ a.s.}$$

Since

$$\sup_{t \geq 0} \left( e^{-\eta t} Z^{(i)}(t) \right) = e^{-\eta T^{(i)}} \sup_{t \geq 0} \left( e^{-\eta t} X_{(i)}(t) \right),$$

we have

$$\sum_{i \geq 1} \sup_{t \geq 0} \left( e^{-\eta t} Z^{(i)}(t) \right) = \sum_{i \geq 1} e^{-\eta T^{(i)}} J_i$$

where  $J_i := \sup_{t \geq 0} \left( e^{-\eta t} X_{(i)}(t) \right)$  for  $i \geq 1$  and  $J_1, J_2, \dots$  are i.i.d. Thus, using Lemmas 4.2, this series a.s. converges if  $\mathbb{E}[\log^+ J_1]$  is finite, which is checked thanks to Proposition 2.1(ii).

Then we get (18) and using the dominated convergence theorem,

$$I := \lim_{t \rightarrow \infty} e^{-\eta t} I(t) = \sum_{i \geq 1} e^{-\eta T^{(i)}} E_i \text{ a.s.}$$

In order to find the law of  $I$ , we compute its Laplace transform. For  $a > 0$ , using part(i) of this theorem,

$$\mathbb{E} \left[ e^{-ae^{-\eta t} I(t)} \right] = G_t(e^{-ae^{-\eta t}}) = \left( e^{-ae^{-\eta t}} + \left( 1 - e^{-ae^{-\eta t}} \right) W(t) \right)^{-\theta/b}$$

and

$$e^{-ae^{-\eta t}} + \left( 1 - e^{-ae^{-\eta t}} \right) W(t) \underset{t \rightarrow \infty}{\sim} 1 + ae^{-\eta t} W(t) \underset{t \rightarrow \infty}{\rightarrow} 1 + \frac{a}{c}$$

using Lemma 4.1 (ii). Then,

$$\mathbb{E} \left[ e^{-aI} \right] = \left( \frac{c}{a+c} \right)^{\theta/b}$$

which is the Laplace transform of a Gamma( $\theta/b, c$ ) random variable.

## 5. OTHER PROOFS

**5.1. Proof for Model I.** To prove Theorem 2.4, we will follow Tavaré's proof [22]. We begin with a technical lemma which will be useful in the proof of this theorem and in forthcoming proofs.

**Lemma 5.1.** *Let  $(T_i, i \geq 1)$  be the arrival times of a Poisson process with parameter  $\alpha$  and  $\zeta_1, \zeta_2, \dots$  be i.i.d. r.v. independent of the  $T_i$ 's. Denote by  $g$  the density of  $\zeta_1$  with respect to Lebesgue measure and by  $F(v) := \mathbb{P}(\zeta_1 \geq v)$  its distribution tail. Then for  $r > 0$ ,  $(e^{-rT_i} \zeta_i, i \geq 1)$  are the points of a non-homogeneous Poisson point process on  $(0, \infty)$  with intensity measure  $\frac{\alpha}{r} \frac{F(v)}{v} dv$ .*

*Proof.* We first study the collection  $\Pi = \{(T_i, \zeta_i), i \geq 1\}$ . This is a Poisson point process on  $(0, \infty) \times (0, \infty)$  with intensity measure  $\alpha g(y) dt dy$ . Then,  $(e^{-rT_i} \zeta_i, i \geq 1)$  is a Poisson point process whose intensity measure is the image of  $\alpha g(y) dt dy$  by  $(t, y) \mapsto e^{-rt} y$ . We now compute it. Let  $h$  be a non-negative mapping. Changing variables, we get

$$\begin{aligned} \int_0^\infty \int_0^\infty h(e^{-rt} y) \alpha g(y) dt dy &= \frac{\alpha}{r} \int_0^\infty h(v) dv \int_0^1 g\left(\frac{v}{u}\right) \frac{du}{u^2} \\ &= \frac{\alpha}{r} \int_0^\infty h(v) \frac{F(v)}{v} dv \end{aligned}$$

and the proof is completed.  $\square$

We are now able to prove Theorem 2.4. By Proposition 2.2 and Theorem 2.3,

$$I(t)^{-1}(Z^{(1)}(t), Z^{(2)}(t), \dots) = \frac{e^{-\eta t}(Z^{(1)}(t), Z^{(2)}(t), \dots)}{e^{-\eta t} I(t)} \xrightarrow[t \rightarrow \infty]{} \left(\frac{\sigma_1}{\sigma}, \frac{\sigma_2}{\sigma}, \dots\right) \quad \text{a.s.}$$

where  $\sigma_i := \exp(-\eta T^{(i)}) E_i$  and  $\sigma := \sum_{i \geq 1} \sigma_i$ .

Moreover, the  $(\sigma_i)_{i \geq 1}$  are the points of a non-homogeneous Poisson point process on  $(0, \infty)$  with intensity measure  $\frac{\theta}{b} \frac{e^{-cy}}{y} dy$  thanks to Lemma 5.1 with  $\alpha = \theta\eta/b$ ,  $r = \eta$  and  $F(v) = e^{-cv}$  because  $(T^{(i)})_{i \geq 1}$  is a Poisson process of rate  $\theta\eta/b$  and  $(E_i)_{i \geq 1}$  is an independent sequence of i.i.d. exponential variables with parameter  $c$ .

According to [3, p. 89], the Poisson point process  $(\sigma_i)_{i \geq 1}$  satisfies  $\sigma = \sum_{i \geq 1} \sigma_i < \infty$  (actually  $\sigma$  has a Gamma distribution) and the vector

$$\left(\frac{\sigma_1}{\sigma}, \frac{\sigma_2}{\sigma}, \dots\right)$$

follows the GEM distribution with parameter  $\theta/b$  and is independent of  $\sigma$ .

**5.2. Proof for Model II.** We will prove Theorem 2.5. We recall that in Model II, immigrants are of type  $i$  with probability  $p_i$ . Denote by  $N^i(t)$  the number of immigrants of type  $i$  which arrived before time  $t$ . Then,  $(N^i(t), t \geq 0)$  is a Poisson process with parameter  $\theta p_i$  and the processes  $(N^i, i \geq 1)$  are independent. Hence,  $I_1(t), I_2(t), \dots$  are independent and their asymptotic behaviors are the same as  $I(t)$  in Theorem 2.3, replacing  $\theta$  with  $\theta p_i$ . Then we have

$$e^{-\eta t} I_i(t) \xrightarrow[t \rightarrow \infty]{} I_i \quad \text{a.s.} \quad i \geq 1$$

where the  $I_i$ 's are independent and  $I_i$  has a Gamma distribution  $\Gamma(\alpha_i, c)$  (recall that  $\alpha_i = \theta p_i/b$ ).

Moreover,

$$e^{-\eta t} I(t) \xrightarrow[t \rightarrow \infty]{} I \quad \text{a.s.}$$

where  $I \sim \Gamma(\theta/b, c)$ . Therefore, for  $r \geq 1$ ,

$$\lim_{t \rightarrow \infty} I(t)^{-1}(I_1(t), \dots, I_r(t)) = \left(\frac{I_1}{I}, \dots, \frac{I_r}{I}\right) \quad \text{a.s.}$$

In order to investigate the law of this  $r$ -tuple, we prove that

$$(19) \quad I = \sum_{i \geq 1} I_i \quad \text{a.s.}$$

First, by Fatou's lemma,

$$\liminf_{t \rightarrow \infty} e^{-\eta t} \sum_{i \geq 1} I_i(t) \geq \sum_{i \geq 1} \liminf_{t \rightarrow \infty} e^{-\eta t} I_i(t) \text{ a.s.}$$

and so

$$I \geq \sum_{i \geq 1} I_i \text{ a.s.}$$

Second,

$$\mathbb{E} \left[ \sum_{i \geq 1} I_i \right] = \sum_{i \geq 1} \frac{\alpha_i}{c} = \frac{\theta}{bc} = \mathbb{E}[I].$$

The last two equations yield (19). For  $1 \leq i \leq r$ , we can write

$$\frac{I_i}{I} = \frac{I_i}{I_1 + \dots + I_r + I^*}$$

where  $I^*$  is independent of  $(I_i, 1 \leq i \leq r)$  and has a Gamma distribution  $\Gamma(\theta/b - \bar{\alpha}_r, c)$  with  $\bar{\alpha}_r := \sum_{i=1}^r \alpha_i$ . Hence, one can compute the joint density of the  $r$ -tuple  $(I_1/I, \dots, I_r/I)$  as follows

$$f(x_1, \dots, x_r) = \frac{\Gamma(\theta/b)}{\Gamma(\theta/b - \bar{\alpha}_r) \prod_{i=1}^r \Gamma(\alpha_i)} x_1^{\alpha_1-1} \dots x_r^{\alpha_r-1} (1 - x_1 - \dots - x_r)^{\theta/b - \bar{\alpha}_r - 1}$$

for  $x_1, \dots, x_r > 0$  satisfying  $x_1 + \dots + x_r < 1$ . This joint density is exactly that of  $(P'_1, \dots, P'_r)$  defined in the statement of the theorem.

**5.3. Proofs for Model III.** We first prove the almost sure convergence in Proposition 2.8. In order to do that, we use the same arguments as in the proof of Theorem 2.3(ii): we will use the dominated convergence theorem for the sum

$$e^{-\eta t} I(t) = \sum_{i \geq 1} e^{-\eta t} I_{\Delta_i}^i(t - T_i) \mathbf{1}_{\{t \geq T_i\}}.$$

As in a previous proof, this sum is bounded by  $\sum_{i \geq 1} e^{-\eta T_i} \sup_{t \geq 0} (e^{-\eta t} I_{\Delta_i}^i(t))$  which, according to

Lemma 4.2, is a.s. finite if

$$\mathbb{E} \left[ \log^+ \sup_{t \geq 0} (e^{-\eta t} I_{\Delta}^1(t)) \right] < \infty.$$

However,  $I_{\Delta}^1(t) = \sum_{i \geq 1} X^i(t - \tilde{T}_i) \mathbf{1}_{\{t \geq \tilde{T}_i\}}$  where conditionally on  $\Delta$ ,  $(\tilde{T}_i, i \geq 1)$  is a Poisson process with parameter  $\Delta$ . Hence,

$$\sup_{t \geq 0} (e^{-\eta t} I_{\Delta}(t)) \leq \sum_{i \geq 1} e^{-\eta \tilde{T}_i} \sup_{t \geq 0} (e^{-\eta t} X^i(t)) = \sum_{i \geq 1} e^{-\eta \tilde{T}_i} J_i$$

where  $J_1, J_2, \dots$  is an i.i.d. sequence of random variables independent from  $\tilde{T}_1, \tilde{T}_2, \dots$  distributed as  $\sup_{t \geq 0} (e^{-\eta t} X(t))$  where  $(X(t), t \geq 0)$  is a homogeneous CMJ-process. According to Proposition 2.1(ii), we know that  $\mathbb{E}[(\log^+ J_1)^2] < \infty$ .

We define for  $i \geq 1$ ,  $\varsigma_i := e^{-\eta \tilde{T}_i} J_i$  and  $\varsigma := \sum_{i \geq 1} \varsigma_i$  and we have to prove that  $\mathbb{E}[\log^+ \varsigma]$  is finite. To do that, we first work conditionally on  $\Delta$ . According to Lemma 5.1, we know

that  $(\varsigma_i, i \geq 1)$  are the points of a non-homogeneous Poisson process on  $(0, \infty)$  with intensity measure  $\frac{\Delta}{\eta} \frac{L(v)}{v} dv$  where  $L(v) := \mathbb{P}(J \geq v)$ . Then, using the inequality

$$\log^+(x + y) \leq \log^+ x + \log^+ y + \log 2, \quad x, y \geq 0,$$

we have

$$(20) \quad \mathbb{E}[\log^+ \varsigma] \leq \log 2 + \mathbb{E} \left[ \log^+ \sum_{i \geq 1} \varsigma_i \mathbf{1}_{\{\varsigma_i \leq 1\}} \right] + \mathbb{E} \left[ \log^+ \sum_{i \geq 1} \varsigma_i \mathbf{1}_{\{\varsigma_i > 1\}} \right]$$

We first consider the second term of the r.h.s.

$$(21) \quad \mathbb{E} \left[ \log^+ \sum_{i \geq 1} \varsigma_i \mathbf{1}_{\{\varsigma_i \leq 1\}} \right] \leq \mathbb{E} \left[ \sum_{i \geq 1} \varsigma_i \mathbf{1}_{\{\varsigma_i \leq 1\}} \right] = \int_0^1 v \frac{\Delta}{\eta} \frac{L(v)}{v} dv \leq \frac{\Delta}{\eta}.$$

Then, we compute the third term of the r.h.s. of (20): if  $A := \sup_i \varsigma_i$ ,

$$\begin{aligned} \mathbb{E} \left[ \log^+ \sum_{i \geq 1} \varsigma_i \mathbf{1}_{\{\varsigma_i > 1\}} \right] &\leq \mathbb{E} [\log^+ (A \cdot \#\{i \geq 1 | \varsigma_i > 1\})] \\ &\leq \mathbb{E} [\log^+ A] + \mathbb{E} [\log^+ \#\{i \geq 1 | \varsigma_i > 1\}] \end{aligned}$$

Furthermore, the number of  $\varsigma_i$  greater than 1 has a Poisson distribution with parameter  $\int_1^\infty \frac{\Delta}{\eta} \frac{L(v)}{v} dv$ . Since  $\mathbb{E}[\log^+ J] < \infty$ ,

$$\int_0^\infty \mathbb{P}(\log^+ J \geq s) ds = \int_0^\infty \mathbb{P}(J \geq e^s) ds = \int_1^\infty \frac{L(v)}{v} dv < \infty.$$

Then,

$$(22) \quad \mathbb{E} [\log^+ \#\{i \geq 1 | \varsigma_i > 1\}] \leq \mathbb{E} [\#\{i \geq 1 | \varsigma_i > 1\}] = \frac{\Delta}{\eta} \int_1^\infty \frac{L(v)}{v} dv \leq C \Delta$$

where  $C$  is a finite constant which does not depend on  $\Delta$ .

We now want to study  $A$ :

$$\mathbb{P}(A \leq x) = \mathbb{P}(\#\{i \geq 1 | \varsigma_i > x\} = 0) = \exp \left( - \int_x^\infty \frac{\Delta}{\eta} \frac{L(v)}{v} dv \right), \quad x > 0.$$

So that

$$\mathbb{P}(A \in dx) = \frac{\Delta}{\eta} \frac{L(x)}{x} \exp \left( - \int_x^\infty \frac{\Delta}{\eta} \frac{L(v)}{v} dv \right) dx.$$

Then,

$$\begin{aligned} \mathbb{E}[\log^+ A] &= \int_1^\infty \log x \frac{\Delta}{\eta} \frac{L(x)}{x} \exp \left( - \int_x^\infty \frac{\Delta}{\eta} \frac{L(v)}{v} dv \right) dx \\ &\leq \frac{\Delta}{\eta} \int_1^\infty \log x \frac{L(x)}{x} dx = \frac{\Delta}{\eta} \int_0^\infty u L(e^u) du \\ (23) \quad &\leq \frac{\Delta}{\eta} \int_0^\infty u \mathbb{P}(\log^+ J \geq u) du \leq C' \Delta \end{aligned}$$

where  $C'$  is a finite constant since  $\mathbb{E}[(\log^+ J)^2] < \infty$  according to Proposition 2.1(ii). Hence, with (21), (22) and (23) we have

$$\mathbb{E}[\log^+ \varsigma | \Delta] \leq \log 2 + C'' \Delta.$$

Then,  $\mathbb{E}[\log^+ \varsigma]$  is finite because  $\mathbb{E}[\Delta] = \alpha^{-1} \int_0^\infty x^2 f(x) dx < \infty$ . and, using the dominated convergence theorem,  $e^{-\eta t} I(t)$  a.s. converges toward  $\sigma = \sum_{i \geq 1} e^{-\eta T_i} G_i$  as  $t \rightarrow \infty$ .

We now compute the law of the limit  $\sigma$ . We define  $\sigma_i := \exp(-\eta T_i) G_i$  for  $i \geq 1$ . Then, using Lemma 5.1,  $(\sigma_i)_{i \geq 1}$  are the points of a non-homogeneous Poisson point process on  $(0, \infty)$  with intensity measure  $\frac{\alpha}{\eta} \frac{F(y)}{y} dy$  where  $F(y) = \mathbb{P}(G \geq y)$ . To compute the Laplace transform of  $\sigma$ , we use the exponential formula for Poisson processes: for  $s > 0$ ,

$$\mathbb{E}[e^{-s\sigma}] = \exp\left(-\frac{\alpha}{\eta} \int_0^\infty \frac{F(v)}{v} (1 - e^{-sv}) dv\right).$$

and to get the expectation of  $\sigma$ , we differentiate the last displayed equation at 0:

$$\mathbb{E}[\sigma] = \frac{\alpha}{\eta} \int_0^\infty F(v) dv = \frac{\alpha}{\eta} \mathbb{E}[G]$$

and

$$\mathbb{E}[G] = \alpha^{-1} \int_0^\infty x f(x) \frac{x}{b} \frac{1}{c} dx < \infty$$

Hence,

$$\mathbb{E}[\sigma] = \frac{1}{\eta bc} \int_0^\infty x^2 f(x) dx < \infty$$

which ends the proof of Proposition 2.8.

It remains to prove Theorem 2.9 that is to show that the vector  $(Z^1(t), Z^2(t), \dots)/I(t)$  a.s. converges to a Poisson point process with intensity measure  $\frac{\alpha}{\eta} \frac{F(y)}{y} dy$ . It is straightforward using previous calculations, Propositions 2.7 and 2.8.

**Remark 5.2.** Thanks to similar calculations as in Theorem 2.3(i), we can compute the generating function of  $I(t)$

$$\mathbb{E}[s^{I(t)}] = \exp\left(-\int_0^t du \left(\alpha - \int_0^\infty \frac{x f(x)}{(W(u)(1-s) + s)^{x/b}} dx\right)\right), \quad s \in [0, 1].$$

and we can deduce the law of  $\sigma$  in another way.

#### ACKNOWLEDGMENTS

I want to thank my supervisor, Amaury Lambert, for his very helpful remarks.

#### REFERENCES

- [1] ATHREYA, K. B. AND NEY, P. E. (1972). *Branching processes*. Springer-Verlag, New York. Die Grundlehren der mathematischen Wissenschaften, Band 196.
- [2] BERTOIN, J. (1996). *Lévy processes* vol. 121 of *Cambridge Tracts in Mathematics*. Cambridge University Press, Cambridge.
- [3] BERTOIN, J. (2006). *Random fragmentation and coagulation processes* vol. 102 of *Cambridge Studies in Advanced Mathematics*. Cambridge University Press, Cambridge.
- [4] CASWELL, H. (1976). Community structure: A neutral model analysis. *Ecological Monographs* **46**, 327–354.
- [5] DONNELLY, P. AND TAVARÉ, S. (1986). The ages of alleles and a coalescent. *Adv. in Appl. Probab.* **18**, 1–19.



- [6] DURRETT, R. (1999). *Essentials of stochastic processes*. Springer Texts in Statistics. Springer-Verlag, New York.
- [7] ETHIER, S. N. (1990). The distribution of the frequencies of age-ordered alleles in a diffusion model. *Adv. in Appl. Probab.* **22**, 519–532.
- [8] FISHER, R., CORBET, A. AND WILLIAMS, C. (1943). The relation between the number of species and the number of individuals in a random sample of an animal population. *Journal of Animal Ecology* **12**, 42–58.
- [9] GEIGER, J. AND KERSTING, G. (1997). Depth-first search of random trees, and Poisson point processes. In *Classical and modern branching processes (Minneapolis, MN, 1994)*. vol. 84 of *IMA Vol. Math. Appl.* Springer, New York pp. 111–126.
- [10] HARRIS, T. E. (1963). *The theory of branching processes*. Die Grundlehren der Mathematischen Wissenschaften, Bd. 119. Springer-Verlag, Berlin.
- [11] HUBBELL, S. (2001). *The Unified Neutral Theory of Biodiversity and Biogeography*. Princeton Univ. Press, NJ.
- [12] JAGERS, P. (1975). *Branching processes with biological applications*. Wiley-Interscience, London.
- [13] KALLENBERG, O. (2002). *Foundations of modern probability* second ed. Probability and its Applications (New York). Springer-Verlag, New York.
- [14] KARLIN, S. AND MCGREGOR, J. (1967). The number of mutant forms maintained in a population. *Proc. 5th Berkeley Symposium Math. Statist. Prob.* **IV**, 415–438.
- [15] KENDALL, D. G. (1948). On some modes of population growth leading to R. A. Fisher’s logarithmic series distribution. *Biometrika* **35**, 6–15.
- [16] LAMBERT, A. (2008). Population dynamics and random genealogies. *Stoch. Models* **24**, 45–163.
- [17] LAMBERT, A. (2010). The contour of splitting trees is a Lévy process. *Ann. Probab.* **38**, 348–395.
- [18] LAMBERT, A. (2010). Species abundance distributions in neutral models with immigration or mutation and general lifetimes. Preprint available at [http://www.proba.jussieu.fr/pageperso/amaury/index\\_fichiers/MigraMut.pdf](http://www.proba.jussieu.fr/pageperso/amaury/index_fichiers/MigraMut.pdf). To appear in *J. Math. Biol.*
- [19] MACARTHUR, R. AND WILSON, E. (1967). *The Theory of Island Biogeography*. Princeton Univ. Press, NJ.
- [20] NERMAN, O. (1981). On the convergence of supercritical general (C-M-J) branching processes. *Z. Wahrsch. Verw. Gebiete* **57**, 365–395.
- [21] REVUZ, D. AND YOR, M. (1999). *Continuous martingales and Brownian motion* third ed. vol. 293 of *Grundlehren der Mathematischen Wissenschaften [Fundamental Principles of Mathematical Sciences]*. Springer-Verlag, Berlin.
- [22] TAVARÉ, S. (1987). The birth process with immigration, and the genealogical structure of large populations. *J. Math. Biol.* **25**, 161–168.
- [23] TAVARÉ, S. (1989). The genealogy of the birth, death, and immigration process. In *Mathematical evolutionary theory*. Princeton Univ. Press, Princeton, NJ pp. 41–56.
- [24] VOLKOV, I., BANAVAR, J. R., HUBBELL, S. P. AND MARITAN, A. (2003). Neutral theory and relative species abundance in ecology. *Nature* **424**, 1035–7.
- [25] WATTERSON, G. A. (1974). Models for the logarithmic species abundance distributions. *Theoret. Population Biology* **6**, 217–250.
- [26] WATTERSON, G. A. (1974). The sampling theory of selectively neutral alleles. *Advances in Appl. Probability* **6**, 463–488.