

Lab-scale prototype for on-line monitoring and energy diagnosis in buildings

Thierry Talbert, Benjamin Paris, Julien Eynard, Stéphane Grieu and Olivier Fruchier
 ELIAUS laboratory, University of Perpignan Via Domitia, Perpignan, France
 {talbert; benjamin.paris; julien.eynard; grieu; olivier.fruchier}@univ-perp.fr

Introduction

Regarding to greenhouse gases emission or supplying cost, energy consumption in buildings is nowadays a problem. So, an appropriate energy management in buildings is mandatory for enhancing energy savings and promoting renewable energy resources. Thus, the present paper focuses on presenting a lab-scale prototype for (i) on-line monitoring energy consumption, (ii) on-line computing a global energy indicator and (iii) estimating the renewable energy potential of a location. These three points define an energy diagnosis based on energy consumption segmentation. The main goal of developing a lab-scale prototype is testing some usable tools for achieving an energy management in buildings by means of the above-mentioned energy diagnosis.

The lab-scale prototype is composed of a building mock-up, a monitoring system and a data post-treatment software. The monitoring system is being developed, in collaboration with industrial partners, APEX-BP SOLAR, Pyrescom and the "Centre Scientifique et Technique du Bâtiment" (CSTB), for measuring and recording both mock-up temperatures and energy consumption. In addition, this monitoring system records also outdoor parameters, such as solar radiation and wind speed, for estimating the real renewable energy potential of the location.

This paper presents, first, the energetic situation in France and the related documentation, and, secondly, a detailed presentation of the lab-scale prototype. A conclusion ends the paper.

Energetic situation in France

Fossil energy consumption is due to different sectors such as transport or industry. In France, the building sector represents 42 % of the overall energy consumed and 25 % of greenhouse gases emissions [1]. So, the main objective of the French "*Grenelle de l'Environnement*" is about reducing energy consumption of 20 % in existing buildings during the five next years.

French energy documentations

Enhancing the energy performance of buildings, for promoting energy savings, is already encouraged by the legal documentation, e.g. the RT 2005 "Réglementation Thermique 2005" [2]. RT 2005 provides the material energy performance to respect

and the conventional energy consumptions for the future building, taking into account heating, ventilation, cooling and electricity consumptions. Conventional energy consumptions also serve of reference for HPE ("Haute Performance Energétique") and THPE ("Très Haute Performance Energétique") labels, respectively 10 % and 20 % of consumption reductions.

Moreover, the DPE ("Diagnostic de Performance Energétique") [3] was created to characterize the existing buildings (figure 1), using a global energy indicator: kWh,m⁻²,year⁻¹. Some others European labels exist, PassivHaus and Minergie, using approximately the same reasoning and the same indicator.

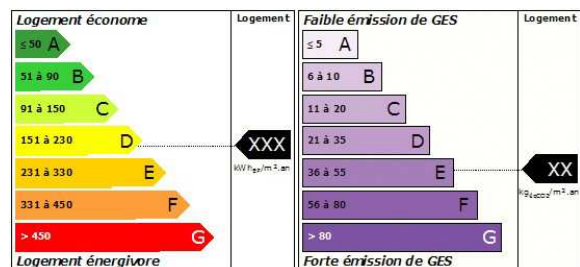

Fig 1: DPE results.

Software, such as "3CL Excel®" (CSTB), which are based on building materials parameters (thermal conductivity insulation, glazing losses ...), on the building design or equipment, can be used to compute DPE to classify buildings according to their levels of energy consumption.

The DPE is the first step of an energy diagnosis, because it is just a "static calculation". It is more interesting and real to diagnose the energy performance of a building in real time. Indeed, to improve energy management of buildings, we can consider two complementary approaches:

- optimize the buildings structurally by the choice of efficient materials,
- use the monitoring tools to control the use of renewable energy and fossil fuels.

The work presented in this article meet the second approach to control the energy building behavior.

Energy indicator calculation

Global energy indicator, i.e. kWh,m⁻²,year⁻¹, used in the different documentations, can be performed to

enhance energy management in building. It serves of reference to characterize a building.

The energy indicator calculation is done almost as follow:

- 1 register all the energy consumptions of the building,
- 2 measured the different energy consumptions with appropriate sensors,
- 3 compute the global energy consumption in real time,
- 4 add the building area.

From this study, we are able to generate a real global indicator to define a building. Then, this buildings could be compared at others buildings, using the scale of the figure 1, or for example HPE and THPE labels consumption references (for a same type of building).

To compute this indicator and work on energy performance and building classification, a lab-scale prototype is designed. In addition, the lab-scale serves to test different controllers on energy facilities to enhance energy management (see post treatment software),

Lab-scale prototype

The prototype is divided into two parts:

- a building mock-up, with a complete set of sensors and two heating resources,
- an electronic device to compute in real time the mock-up energy indicator, and to control the heating sources.

Why have-we chosen a mock-up instead of a real building?

We are looking for a building:

- with several measurements (temperature, electricity, environmental parameters, ...),
- we can manage (whatever the day of the year and the external temperature),
- where we can easily add sensors, change command rules etc,
- where two different heating resources are available (electricity and/or renewable energy).

Thus, we have to solve 3 problems if we want to present a real time solution that compute energy diagnosis:

- 1 a building with all the sensors. This is possible but need an human and material investment too important at this point of the project,
- 2 a building using two different heating resources (the buildings of the University of Perpignan use electricity and fuel for heating but none renewable energy resources),

- 3 a building we can control. That's maybe the bigger problem we have to solve. Changing regulation to test the monitoring is not possible if people are there. And more important, we have to by-pass the regulation integrated into air-conditioner, hot pump heaters etc. with all the consequences (destruction of electronic and/or mechanical, loss of warranty etc).

That's why we have developed this lab-scale prototype, we'll present on the following paragraphs.

Building mock-up

The prototype of the building is a a mock-up (figure 2), which scale is 1/27, based on a real one floor house of 128 m². With this size, the small house allows fast and simple sensor modifications. This flexibility provides (i) constructing a simple and reliable electronic, (ii) choosing the best position for sensors (iii) the replacement of the heaters.

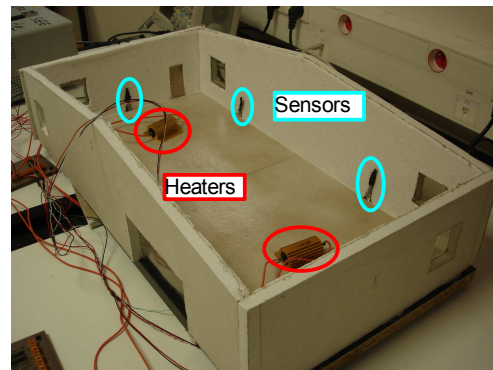

Fig 2: Building mock-up.

The mock-up design is done three steps:

- 1 the physical scale,
- 2 the materials choice,
- 3 the instrumentation.

Physical scale

The main idea is the ratio between a real height of concrete floor (almost 20 cm) and the substitute material. Indeed, we chose a 6 mm height ceramic tile for the floor: homogeneity is approximately equal to concrete. From this ratio, the walls and windows thickness are directly determined like the building insulation.

Materials choice

The material choices answers at a few recommendations:

- the thickness must to respect the predefined scale,
- the thermal and hygrometry behaviour must to be more as possible the same as a real wall.

Thus, we choose 13 mm of plasterboard (BA13) for

the walls, 4 mm of polystyrene for insulation and 4 µm of polyane for the windows.

Instrumentation

Sheath for sensors and actuators cables are located along the walls and go through the tile. Half of the roof can be detached in order to modify sensor and actuators localisation. Eight temperature sensors composed the mock-up instrumentation: seven indoor sensors and one outdoor sensor. In addition, two resistors represent the fossil and the renewable energy resources, The power of the resistor is estimated in the following section.

Heating power

To estimate the heating power, several points are essentials:

1. thermal conductivity for each materials ($W, m^{-1} \cdot ^\circ C^{-1}$),
2. calculated thermal resistivity ($m^2 \cdot ^\circ C, W^{-1}$) using the material thickness,
3. all the wall areas,
4. calculated losses coefficient D_{bat} of the mock-up, including thermal bridges.

The maximum value of the power used to heat the mock-up is given by an empirical formula (equation 1):

$$P(W) = D_{bat} \cdot S \cdot (T_{sp} - T_{out}) \quad (\text{eq: 1})$$

where

- D_{bat} : losses coefficient $W, m^{-2} \cdot ^\circ C^{-1}$,
- S : heating area m^2 ,
- T_{sp} : temperature set point $^\circ C$,
- T_{out} : reference of the outdoor temperature.

If we chose a temperature set point at 19 $^\circ C$, and a reference outdoor temperature of -5 $^\circ C$, the minimal value of the heaters is 55 W. This value explains the two resistors of 22 Ω under 24 VDC inside the mock-up.

After the building mock-up, the electronic device is detailed.

Electronic device

The electronic device is realised in collaboration with industrial partners: Pyrescom SA, Apex-BP Solar and CSTB. The monitoring station (i) implementation should be easy and (ii) total cost should remain rather low. The prototypes of the station is implemented at three different locations (Apex BP Solar and Pyrescom headquarters and at the University of Perpignan). The device presented on this paper are the laboratory prototypes with heaters interface (this part is not present on the industrial version).

The monitoring system is divided into two separated parts: (i) a core-bloc (composed of a low power processor, is corresponding memory (RAM and FLASH), and integrated hosts controllers), and (ii) a set of adaptable bloc sensors, which means that it is possible to record and process different data. This electronic device also uses a Controlled Area Network (CAN) bus, a low power consumption processor and an encrypted communication system to secure data access.

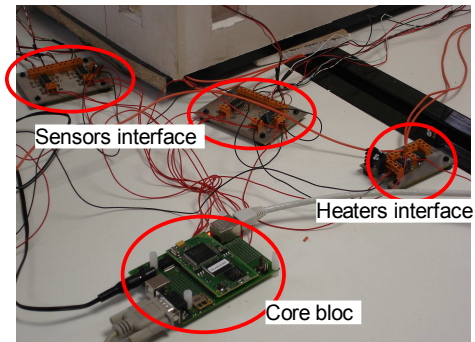

Fig 3: Laboratory monitoring station without IHM.

As mentioned, with the chosen architecture, it is possible to use both, informations concerning energy consumptions and operating conditions measurements. The smart transducers transmit data to the monitoring system, through preferably a CAN bus.

Figure 4 and 5 shows the electronic device example of the University's offices, where one of the laboratory experimental device is under evaluation.

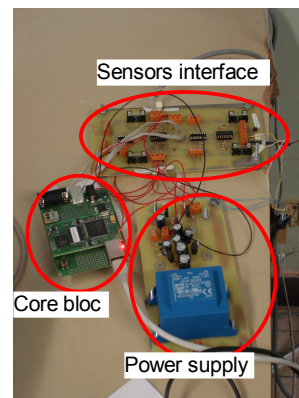

Fig 4: Prototype of office monitoring.

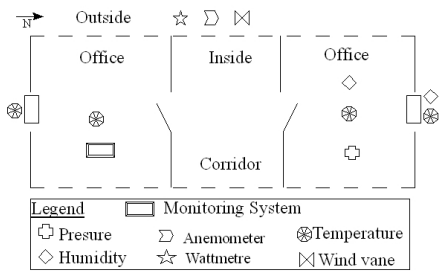

Fig 5: Smart transducers and monitoring system localization (University Offices).

Researches on heating control systems or on energetic efficiency showed that north front temperature and inside temperature measurements are definitely musts for heating control purposes.

In addition, a compromise was found between the number of transducers, avoiding information redundancy and total cost. To generalize this approach to a broader range of customers, indirect measurements were preferred whenever possible. All these sensors can interact with the processor described.

The core bloc use an ARM9[®] processor instead of a micro controller, which is typically used in the metrology literature, since:

- a low level of energy consumption,
- hosts controllers are already integrated for: (i) connectivity, (ii) control purposes, (iii) human interface (CSI, Keypad...), (iv) memory expansion (MMC, PCMCIA...), and (v) providing e.g. Bluetooth communication,
- computation power is higher (4-8 bits versus 32-64 bits, 40 MHz versus 100-400 MHz),
- its high level of memory allows handling a higher number of different kinds of signals.
- control laws can be implemented, e.g. fault diagnosis, fuzzy logics, or energy consumption prediction.

Figure 6 shows how the station is connected to the mock-up. The core block use a Linux operating system. So,

- network is active to control and update the firmware (TCP/IP protocols), no need to program this communication feature.
- security (i.e. encryption) protocols are enabled. Controlling, uploading, downloading files (measurements done by sensors, parameters for sampling and for scaling sensors etc.) are done on a secured environment.
- a web server is active. It uses a small memory footprint, thus following activity of

the station (measured data, error detection, sensor failure etc.) is possible even if we are not directly connected to it.

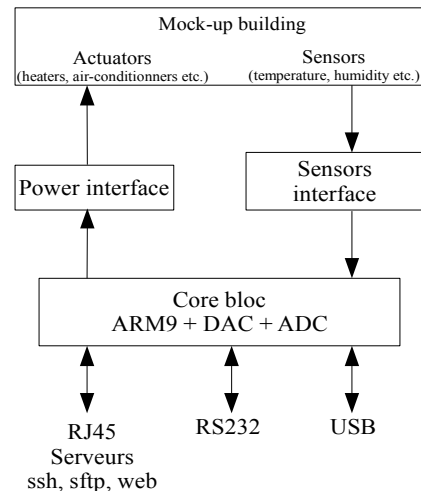

Fig 6: Monitoring station input/output and mock-up connections.

In parallel, the electricity consumption measurement of the monitoring system must be performed to be complete concerning the energy management. Results are shown on Figure 7,

We can establish three working parts:

- Part A: This is the boot of the system. The loader of the station is waiting 30s for a command (like uploading a new firmware, changing boot parameters etc.) and if there is no actions, the boot of the operating system is started. At this point all the components are powered-up but with no activity, except the processor ARM9, the RAM and the RS232 connector. Power consumption is only 1,33 W.
- Part B: This is the boot of the operating system. It operates first by running the Linux kernel (section B1), and next loading all the necessary software (web, acquisition, secure access etc.) in section B2. On the first stage, access are only between the processor and the RAM. On the second stage, this is between the processor, the RAM and the FLASH where is stored the OS. Thus, the power consumption is higher than on the previous stage: 0,28 W more important.
- Part C: here the processor is 90% of its time idle. The 10 % remaining, is recovering data from sensors, compute indicators, save data on the FLASH and verify heaters command. So, power consumption is almost the same as section A of the figure (1,33 W). The 3 spots (C1, C2 and C3)

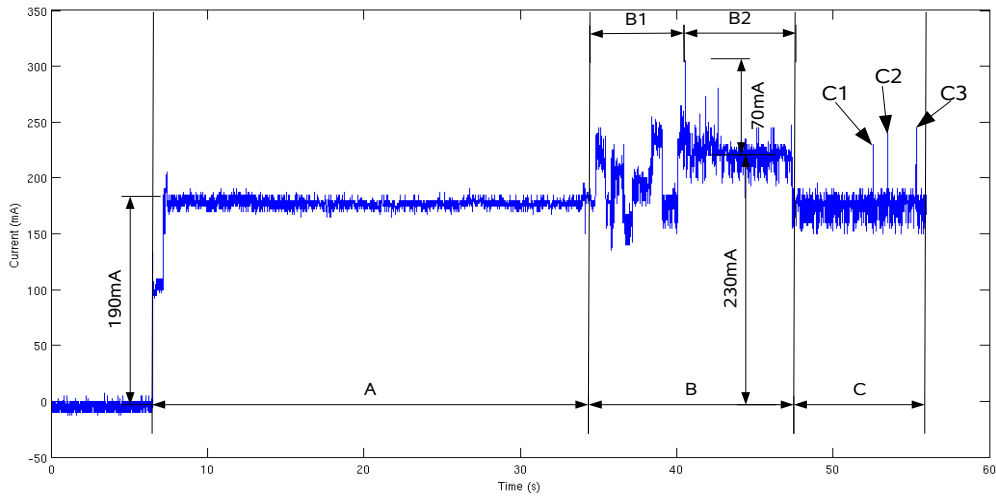

Fig 7: Boot consumption of the station.

represented on figure 7, show when the processor retrieve data from the sensors (C1 and C3) and when the data is stored (C2). Power consumption is higher because, the CPU work at 100 % and all the communication channels are active (FLASH/CPU, CPU/RAM, CPU/SPI, CPU/CAN bus etc.).

Furthermore on figure 10 and 11, on-line measurements and heaters status are available on a web site (loaded all the five minutes).

With this structure, we can complete the monitoring system with actuators and with optimal regulation to increase energy building efficiency.

On-line measurements

Figure 8 and 9 focus on the lab-scale on-line measurements using the electronic device, Several heating powers are send to the electronic device, and all the mock-up temperatures are recorded,

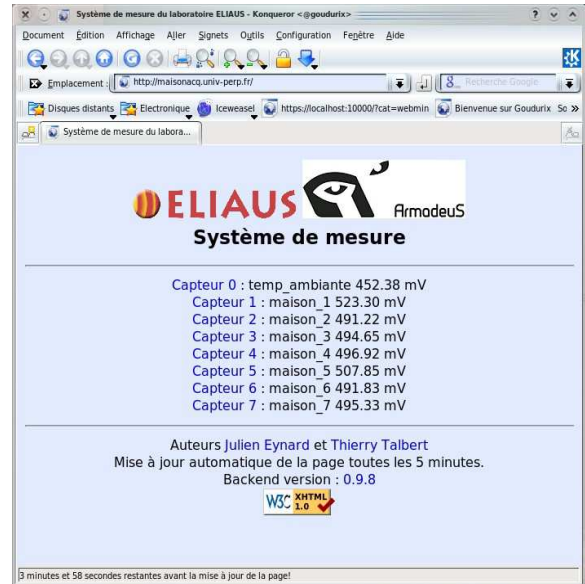

Fig 10: Real-time temperature measurements done inside and outside the mock-up. (Values are shown in mV, and scaled in °C by the station main program.)

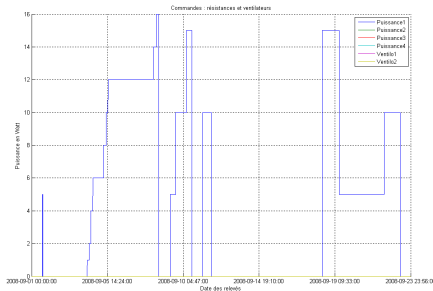

Fig 8: Heating powers.

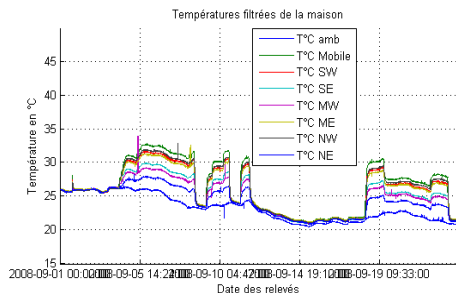

Fig 9: Mock-up temperatures.



Fig 11: On-line measurement of a heating power.

Post-treatment software

The post-treatment software proposes three main works:

- the computation of the global energy indicator already explained
- the use of advance heating controllers
- the calculation of different renewable energy potentials of a location.

First, some alterations to the monitoring software allows adapting the calculation of the global energy indicator to European labels such as the German PassivHaus or Swiss Minergie labels. Indeed, each labels takes into account different energy consumptions (heating, cooling, ventilation,...) and several parameters, The monitoring device is adaptable to gather all the different data required,

Secondly, different advance heating controllers [4] such as PID, MPC, fuzzy logic..., can also be added for enhancing the use of renewable energy resources and the energy savings. The post-treatment software controls for example the mean temperature of a room, with several temperature set points.

In the end, the post-treatment software determines, after an installation of the electronic device into a building, the real potential of the location concerning solar (figure 12) and wind (figure 13) renewable energies. A set of sensors composed by a spektron 300 (solar radiation), an anemometer and a weathercock (made at the laboratory) are connected to the device (figure 14).

The solar and wind speed measurements allow proposing renewable energy resources integration (in this case photovoltaic, solar thermal and wind

turbine). Cost of the modification(s) is evaluated and the return of investment (ROI) also.

In addition, with the energy diagnosis, an evaluation of buildings modifications, to increase efficiency (including material changes, new sources integration etc.) can be realized.



Fig 12: Anemometer and waethercock sensors on the roof of the University.

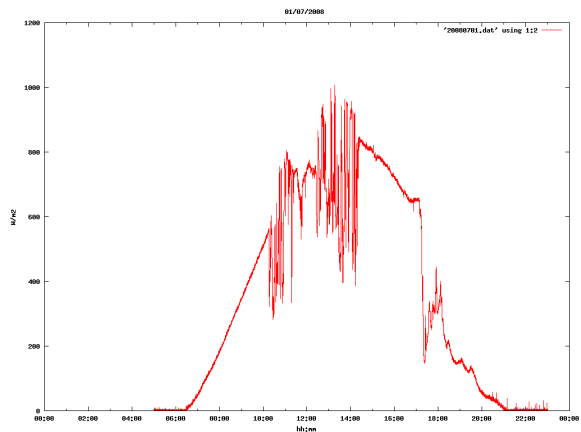

Fig 13: Solar radiation measured the 2008/07/01.

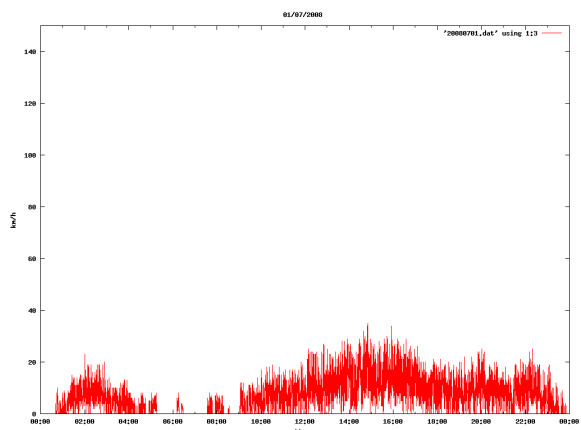

Fig 14: Wind speed measurement done the 2008/07/01.

Conclusions

The aim of the present paper is presenting a plug and play electronic device, connected to a full set of sensors, for evaluating in real-time the energetic efficiency of buildings. This low-cost and low-

consumption device allows measuring energy consumptions and computing an energetic indicator for carrying out an energy diagnosis. This diagnosis is done during a data post-treatment phase which provides the real renewable energy potential and allows controlling energy facilities [5]. A building mock-up has been designed for testing, in real running conditions, the above-mentioned electronic device and its applications.

A commercial version of both electronic device and post-treatment software is under development by our above-mentioned industrial partners.

Future work will now focus on implementing the developed electronic device on real buildings, starting from industrial partner's offices.

Acknowledgements

The authors acknowledges the financial support received from FCE (Fonds de Compétitivité des Entreprises). We want also to thank our partners, the enterprises: Pyrescom SA, Apex-BP Solar and CSTB (Centre Scientifique et Technique du Bâtiment). Without them, this work would not have been

possible.

References

- 1 ADEME (Agence De l'Environnement et de la Maîtrise de l'Energie), « Les chiffres clés du bâtiment en 2006 », Publications de l'ADEME, France, 2007
- 2 République française, « Décret n°2006-592 du 24 mai 2006 relatif aux caractéristiques thermiques et à la performance énergétique des constructions », Journal Officiel, France, 2006.
- 3 République Française, « Décret n°2006-11-47 du 14 septembre 2006 relatif au diagnostic de performance énergétique et à l'état de l'installation intérieure », Journal Officiel, France, 2006.
- 4 B. Paris, J. Eynard, G. François, T. Talbert and M. Polit, « A prototype for on-line monitoring and control of energy performance for renewable energy buildings », ICINCO 2008, 5th International Conference on Informatics in Control, Automation & Robotics, Funchal, Portugal, pp. 125:130, 2008.
- 5 B. Paris, J. Eynard, F. Thiery, A. Traoré, T. Talbert and S. Grieu « Fuzzy-PID control for multisource energy management in buildings », IREED 2008, Montpellier.