



HAL
open science

An LPV Approach for Semi-Active Suspension Control

Anh Lam Do, Olivier Sename, Luc Dugard, Sébastien Aubouet, Ricardo A. Ramirez-Mendoza

► **To cite this version:**

Anh Lam Do, Olivier Sename, Luc Dugard, Sébastien Aubouet, Ricardo A. Ramirez-Mendoza. An LPV Approach for Semi-Active Suspension Control. PACAM XI - 11th Pan-American Congress of Applied Mechanics, Jan 2010, Foz do Iguaçu, Paraná, Brazil. pp.PAC0546. hal-00496934

HAL Id: hal-00496934

<https://hal.science/hal-00496934>

Submitted on 1 Jul 2010

HAL is a multi-disciplinary open access archive for the deposit and dissemination of scientific research documents, whether they are published or not. The documents may come from teaching and research institutions in France or abroad, or from public or private research centers.

L'archive ouverte pluridisciplinaire **HAL**, est destinée au dépôt et à la diffusion de documents scientifiques de niveau recherche, publiés ou non, émanant des établissements d'enseignement et de recherche français ou étrangers, des laboratoires publics ou privés.

AN LPV APPROACH FOR SEMI-ACTIVE SUSPENSION CONTROL

Do Anh-Lam, anh-lam.do@gipsa-lab.grenoble-inp.fr
Sename Olivier, olivier.sename@gipsa-lab.grenoble-inp.fr
Dugard Luc, luc.dugard@gipsa-lab.grenoble-inp.fr
Aubouet Sebastien, sebastien.aubouet@gipsa-lab.grenoble-inp.fr

GIPSA-lab, Control Systems Dept, CNRS-Grenoble INP, ENSE3, BP 46, F-38402 St Martin d'Hères cedex, France

Ricardo Ramirez-Mendoza, ricardo.ramirez@itesm.mx

Mechatronics Department, Tecnológico de Monterrey, Calle del Puente 222 Col. Ejidos de Huipulco Tlalpan, 14380, México, D.F.

Abstract. *In this paper, a new LPV control approach for semi-active automotive suspension equipped with a Magneto-Rheological (MR) damper is presented. The interest of the approach is (1) to embed the model of semi-active suspension in a linear system design and (2) to allow limiting the damper force so that the controlled semi-active suspension works within its admissible region. First, a semi-active suspension model of an MR damper is reformulated in the LPV framework, which provides an LPV model for the vertical car behaviour. Then, by using the H_∞ control approach for polytopic systems, an LPV controller is synthesized to improve the passenger comfort while keeping the road-holding performances. The performances of the LPV controller are analyzed, based on simulations using the embedded nonlinear model of the MR damper.*

Keywords: *automotive control, semi-active suspension model, LPV system, robust control.*

1. INTRODUCTION

In recent years, automotive systems have been widely studied in research and in industry. Among many tackled problems, passenger comfort and safety remain the most important ones. Although a new trend to design a global controller to ensure both comfort and safety has been focused on in the last few years (Ag, 2003; Zin, 2005), the study of single-performance-controller to improve either comfort or safety is still an interesting problem. For the safety oriented problems, efforts are made on stabilizing the vehicle in critical situations by controlling the braking or/and steering systems (Savaresi *et al.*, 2007; Baslamisli *et al.*, 2007) as the well-known ABS, EPS... For the comfort problem, the use of active components such as controlled suspension systems, has allowed to improve the driving comfort thanks to different control approaches like Skyhook (Savaresi & Spelta, 2007; Poussot-Vassal *et al.*, 2006) or H_2/H_∞ (Sammier *et al.*, 2003; Jager, 1997) ones. Recently, it has been shown that suspension system control design is very important because it can improve not only the comfort but also the car safety. The road holding, which is important to be considered in critical driving situations, stands as a key example (Sammier *et al.*, 2003). In (Hac, 2002) for instance, the authors proved that the rollover stability index would be improved by taking into account the effect of suspension design.

Three types of suspension systems exist: passive, semi-active and active dampers. As mentioned previously, many papers have been devoted to the suspension control but most of them have been concerned with active suspensions while semi-active ones (like friction dampers (FD), magnetorheological dampers (MRD)...) are more and more used today in automotive industry because of their small weight and volume, low energy consumption, low price, good performance... A recent solution for the semi-active suspension control problem has been proposed by Poussot-Vassal *et al.* (2008), where a control strategy for the semi-active suspension was introduced using the LPV technique. A scheduling parameter is indeed defined as the difference between the real controlled damper force and the required one, given by the controller.

The main contribution of the present paper is to propose a new LPV approach for controlling the semi-active automotive suspension equipped with MR dampers. First the nonlinear static model of semi-active suspensions presented in (Guo *et al.*, 2006), which accounts for the bi-viscous and hysteretic behaviors of the MR damper, is rewritten as a linear model with varying parameters (LPV). This model is then incorporated in a quarter car model. This gives an LPV controlled oriented model where the scheduling parameters are the bounded continuous functions of deflection and deflection velocity of the damper. The interest of the modeling is that the dissipativity problem is brought into the problem of actuator saturation which may be tackled by recent control methods (for example, anti-windup design). Here the saturation problem is approached using a specific weighting function on the control input.

This paper is organized as follows. In Sec. 2, the LPV model for the quarter car with MR damper is developed and the performance objectives are discussed. In Sec. 3, some outlines about the H_∞ control problem for polytopic systems are presented and a controller for semi-active suspension is designed. In Sec. 4, the results obtained in simulation with a nonlinear quarter car model are discussed. Finally, some conclusions and perspectives are given in Sec. 5.

2. PROBLEM FORMULATION

2.1 System description

Consider a simple quarter vehicle model (see Fig. 1) made up of sprung (m_s) and unsprung masses (m_{us}). A spring with stiffness coefficient k_s and an MR damper connect both masses. The wheel tire is represented by a spring with the stiffness coefficient k_t . In this model, z_s (respectively z_{us}) is the vertical position of m_s (respectively m_{us}) and z_r is the road profile. It is assumed that the wheel-road contact is ensured.

In this paper, the behavior of the semi-active suspension is generated using the following nonlinear model for MR damper (see (Guo *et al.*, 2006)):

$$F_{mr} = a_2 \left(\dot{z}_{def} + \frac{v_0}{x_0} z_{def} \right) + a_1 \tanh \left(a_3 \left(\dot{z}_{def} + \frac{v_0}{x_0} z_{def} \right) \right) \quad (1)$$

with

$z_{def} = z_s - z_{us}$: damper deflection (assumed to be measured or estimated).

$\dot{z}_{def} = \dot{z}_s - \dot{z}_{us}$: deflection velocity (can be directly computed from z_{def}).

where a_2, a_3, v_0 and x_0 are considered as constant parameters, and a_1 varies between a minimum and a maximum value $0 < a_{1min} < a_1 < a_{1max}$.

The dynamical equations of a quarter vehicle are governed by:

$$\begin{cases} m_s \ddot{z}_s = -k_s z_{def} - F_{mr} \\ m_{us} \ddot{z}_{us} = k_s z_{def} + F_{mr} - k_t (z_{us} - z_r) \end{cases} \quad (2)$$

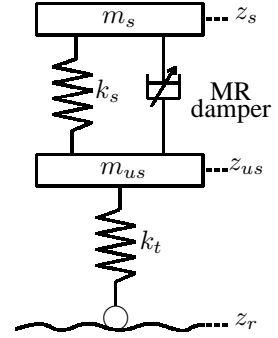

Figure 1. Model of quarter vehicle with MR damper.

2.2 LPV formulation

As seen in 2.1, Eq. (2) represents a non-linear system. In this section, it will be reformulated in the LPV framework by defining new variables. Denoting:

$$\begin{aligned} \rho_1 &= \tanh \left(a_3 \left(\dot{z}_{def} + \frac{v_0}{x_0} z_{def} \right) \right), \\ a_1 &: \text{controllable force,} \\ c_{mr} &= a_2 : \text{MR damper damping coefficient,} \\ k_{mr} &= a_2 \frac{v_0}{x_0} : \text{MR damper stiffness coefficient,} \end{aligned} \quad (3)$$

a state-space representation of the quarter vehicle model (2) can be rewritten from (2) and (3) as follows:

$$\begin{cases} \dot{x}_s = A_s x_s + B_s \rho_1 a_1 + B_{s1} w \\ z = C_{s1} x_s + D_{s1} \rho_1 a_1 \\ y = C_s x_s \end{cases} \quad (4)$$

where

$$x_s = (z_s \quad \dot{z}_s \quad z_{us} \quad \dot{z}_{us})^T, w = z_r, z \text{ represents the controlled outputs and } y \text{ the measured outputs,}$$

$$A_s = \begin{pmatrix} 0 & 1 & 0 & 0 \\ -\frac{k_s+k_{mr}}{m_s} & -\frac{c_{mr}}{m_s} & \frac{k_s+k_{mr}}{m_s} & \frac{c_{mr}}{m_s} \\ 0 & 0 & 0 & 1 \\ \frac{k_s+k_{mr}}{m_{us}} & \frac{c_{mr}}{m_{us}} & -\frac{k_s+k_{mr}+k_t}{m_{us}} & -\frac{c_{mr}}{m_{us}} \end{pmatrix}, B_s = \begin{pmatrix} 0 \\ -\frac{1}{m_s} \\ 0 \\ \frac{1}{m_{us}} \end{pmatrix}, B_{s1} = \begin{pmatrix} 0 \\ 0 \\ 0 \\ \frac{k_t}{m_{us}} \end{pmatrix}$$

C_{s1}, C_s and D_{s1} will be mentioned later in Section 3.

Two main problems: The control signal a_1 must be positive ($0 < a_{1min} < a_1 < a_{1max}$) so that the dissipative constraint is satisfied, and the input matrices ($B_s \rho_1$ and $D_{s1} \rho_1$) in Eq. (4) must be constant (i.e not parameter dependent) to satisfy the LPV/ H_∞ design assumption.

The positivity problem can be solved by defining $u = a_1 - F_0$ where F_0 is the mean value of a_1 (i.e $F_0 = (a_{1min} + a_{1max})/2$). The constraint of positivity of a_1 is recast as a saturation constraint on u (u can take values in $[-F_0; +F_0]$ only). The term $c_{mr} \dot{z}_{def} + k_{mr} z_{def} + F_0 \rho_1$ corresponds to a nominal MR damper force. With this modification, the state-space representation of quarter vehicle model (4) is given as follows:

$$\begin{cases} \dot{x}_s = (A_s + B_{s2} \frac{\rho_1}{C_{s2} x_s} C_{s2}) x_s + B_s \rho_1 u + B_{s1} w \\ z = C_{s1} x_s + D_{s1} \rho_1 u \\ y = C_s x_s \end{cases} \quad (5)$$

$$\text{where } B_{s2} = \left(0; -\frac{F_0}{m_s}; 0; \frac{F_0}{m_{u_s}} \right)^T \quad C_{s2} = \left(\frac{a_3 v_0}{x_0}; a_3; -\frac{a_3 v_0}{x_0}; -a_3 \right)^T$$

The latter problem (concerning the LPV/ H_∞ design assumption) can be solved by adding a strictly proper filter into Eq. (5) to make the controlled input matrices independent from the scheduling parameter (as proposed by Apkarian & Gahinet (1995)):

$$\mathfrak{F} : \begin{pmatrix} \dot{x}_f \\ u \end{pmatrix} = \begin{pmatrix} A_f & B_f \\ C_f & 0 \end{pmatrix} \begin{pmatrix} x_f \\ u_c \end{pmatrix} \quad (6)$$

where A_f, B_f, C_f are constant matrices.

From Eq. (5) and Eq. (6) and denoting $\rho_2 = \frac{\rho_1}{C_{s2}x_s}$, the vertical dynamics of quarter vehicle with MR damper can be now represented by an LPV system with two scheduling parameters ρ_1 and ρ_2 (notice that ρ_1 and ρ_2 are not independent):

$$\begin{cases} \dot{x} = A(\rho_1, \rho_2)x + Bu_c + B_1w \\ z = C_1(\rho_1, \rho_2)x \\ y = Cx \end{cases} \quad (7)$$

where:

$$x = \begin{pmatrix} x_s & x_f \end{pmatrix}^T$$

$$A(\rho_1, \rho_2) = \begin{pmatrix} A_s + \rho_2 B_{s2} C_{s2} & \rho_1 B_s C_f \\ 0 & A_f \end{pmatrix}, B = \begin{pmatrix} 0 \\ B_f \end{pmatrix}, B_1 = \begin{pmatrix} B_{s1} \\ 0 \end{pmatrix}$$

$$C_1(\rho_1, \rho_2) = \begin{pmatrix} C_{s1} & \rho_1 D_{s1} C_f \end{pmatrix}, C = \begin{pmatrix} C_s & 0 \end{pmatrix}$$

In this model the scheduling parameters are defined by:

$$\begin{aligned} \rho_1 &= \tanh(C_{s2}x_s) && \in [-1; 1] \\ \rho_2 &= \frac{\tanh(C_{s2}x_s)}{C_{s2}x_s} && \in [0; 1] \end{aligned} \quad (8)$$

3. CONTROLLER SYNTHESIS

In order to improve the driving comfort (see (Poussot-Vassal *et al.*, 2008)), the "frequency response" from the road disturbance z_r to the vehicle body acceleration \ddot{z}_s (denoted \ddot{z}_s/z_r , by abuse of language) must be kept small in the frequency range [0.5-10] Hz. The frequency response z_s/z_r must be small in [0-4] Hz. Moreover, the actuator saturation must be taken into account (i.e the controlled force must be kept in the range $[-F_0; +F_0]$) so that the dissipativity constraint is satisfied. The frequency response z_{def}/z_r will be a posteriori evaluated to guarantee that the MR damper deflection z_{def} will be kept in a limited range. To carry out a controller satisfying these objectives, the H_∞ design method for LPV systems is used. Note that the computation of the frequency responses, also referred to as Pseudo-Bode plot, is described in (Poussot-Vassal, 2008).

3.1 LPV systems and H_∞ controller

Definition 1 LPV generalized system.

A dynamical LPV system can be described in the following form:

$$\Sigma(\theta) : \begin{pmatrix} \dot{x} \\ z \\ y \end{pmatrix} = \begin{pmatrix} A(\theta) & B_1(\theta) & B_2(\theta) \\ C_1(\theta) & D_{11}(\theta) & D_{12}(\theta) \\ C_2(\theta) & D_{21}(\theta) & D_{22}(\theta) \end{pmatrix} \begin{pmatrix} x \\ w \\ u \end{pmatrix} \quad (9)$$

where x, w and u define the state, the exogenous and control input, respectively; z and y hold for the controlled output and system measurement, respectively. $\theta(\cdot) \in \Theta$ is the set of varying parameters that describe a set of systems. $A \in \mathbb{R}^{n \times n}$, $B_1 \in \mathbb{R}^{n \times n_w}$, $B_2 \in \mathbb{R}^{n \times n_u}$, $C_1 \in \mathbb{R}^{n_z \times n}$, $D_{11} \in \mathbb{R}^{n_z \times n_w}$, $D_{12} \in \mathbb{R}^{n_z \times n_u}$, $C_2 \in \mathbb{R}^{n_y \times n}$, $D_{21} \in \mathbb{R}^{n_y \times n_w}$ and $D_{22} \in \mathbb{R}^{n_y \times n_u}$ are affine in θ .

Definition 2 LPV/ H_∞ controller.

An LPV controller is defined by

$$K(\theta) : \begin{pmatrix} \dot{x}_c \\ u \end{pmatrix} = \begin{pmatrix} A_c(\theta) & B_c(\theta) \\ C_c(\theta) & D_c(\theta) \end{pmatrix} \begin{pmatrix} x_c \\ y \end{pmatrix} \quad (10)$$

where x_c, y and u are the state, the input and output, respectively, of the controller associated to the system (9). $\theta(\cdot) \in \Theta$ is the set of the varying parameters associated to the controller. $A_c(\cdot) \in \mathbb{R}^{n \times n}$, $B_c(\cdot) \in \mathbb{R}^{n \times n_y}$, $C_c(\cdot) \in \mathbb{R}^{n_u \times n}$ and $D_c(\cdot) \in \mathbb{R}^{n_u \times n_y}$ are obtained by solving a LMI problem s.t the closed-loop system is quadratically stable and that, for a given positive real γ , the L_2 -induced norm of the operator mapping the external inputs w into the controlled outputs z is bounded by γ for all parameter values.

The LPV controller is obtained by solving an LMI problem. For details and explanations, see Apkarian & Gahinet (1995) and Scherer *et al.* (1997) or the PhD thesis by Poussot-Vassal (2008). For a polytopic set of parameters, the controller solution is a convex combination of the controllers computed at each vertex of the polytope, as:

$$K(\theta) = \text{Co}\left\{ \begin{pmatrix} A_{c_k} & B_{c_k} \\ C_{c_k} & D_{c_k} \end{pmatrix} \right\} \quad (11)$$

where $k = 1 : 2^i$, i is the number of vertices of the polytope, $\begin{pmatrix} A_{c_k} & B_{c_k} \\ C_{c_k} & D_{c_k} \end{pmatrix}$ is the controller corresponding to the k^{th} vertex (see (Poussot-Vassal, 2008) for more details).

3.2 Controller design for semi-active suspension

With the performance objectives mentioned previously, \ddot{z}_s and z_s are chosen as the controlled outputs. The measurement output is $y = z_s - z_{us}$. The generalized system (4) is completed by defining the following matrices:

$$C_{s1} = \begin{pmatrix} -\frac{k_s+k_{mr}}{m_s} & -\frac{c_{mr}}{m_s} & \frac{k_s+k_{mr}}{m_s} & \frac{c_{mr}}{m_s} \\ 1 & 0 & 0 & 0 \end{pmatrix} \quad D_{s1} = \begin{pmatrix} -\frac{1}{m_s} \\ 0 \end{pmatrix} \quad C_s = \begin{pmatrix} 1 & 0 & -1 & 0 \end{pmatrix}$$

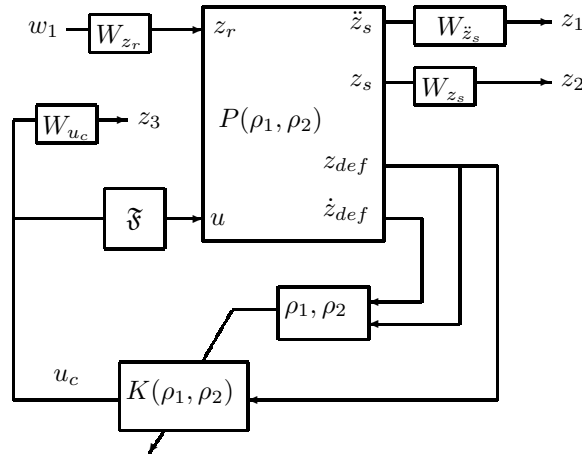

Figure 2. Block diagram for the semi-active suspension control.

To account for performance specifications, some weighting functions are added as usual in the H_∞ control approach. W_{u_c} has been chosen to constraint the control force u and achieve $u \in [-F_0; +F_0]$.

$$W_{\ddot{z}_s} = \frac{s^2 + 2\xi_{11}\Omega_1 s + \Omega_1^2}{s^2 + 2\xi_{12}\Omega_1 s + \Omega_1^2}, \quad W_{z_s} = \frac{s^2 + 2\xi_{21}\Omega_2 s + \Omega_2^2}{s^2 + 2\xi_{22}\Omega_2 s + \Omega_2^2}, \quad W_{z_r} = 3 \times 10^{-2}, \quad W_{u_c} = \frac{0.02}{F_0}$$

where $\Omega_1 = 2\pi f_1 = 70$, $\xi_{11} = 10$, $\xi_{12} = 1$, $\Omega_2 = 2\pi f_2 = 1$, $\xi_{21} = 7$, $\xi_{22} = 0.1$.

The H_∞ control problem for the LVP system $P(\rho_1, \rho_2)$ consists in finding an LPV controller $K(\rho_1, \rho_2)$ such that the closed-loop system is quadratically stable and that, for a given positive real γ , the L_2 -induced norm of the operator mapping w into z is bounded by γ for all possible trajectories (ρ_1, ρ_2) (where $w = w_1$ is the external weighted input vector and $z = [z_1 \ z_2 \ z_3]^T$ the weighted controlled output vector).

As mentioned in Eq. (7), due to the self-dependence between ρ_1 and ρ_2 , the set of parameters (ρ_1, ρ_2) is not convex. In this preliminary study, ρ_1 and ρ_2 are considered to be independent i.e an arbitrary point (ρ_1, ρ_2) belongs to a box with 4 vertices $(\rho_{1max}, \rho_{2max}) = (1, 1)$, $(\rho_{1max}, \rho_{2min}) = (1, 0)$, $(\rho_{1min}, \rho_{2max}) = (-1, 1)$, $(\rho_{1min}, \rho_{2min}) = (-1, 0)$ (see Eq. (8)). A controller for this LPV system is easily found by applying the H_∞ design method - for polytopic systems, as presented above.

4. SIMULATION AND RESULTS

The "Renault Mégane Coupé" model (see (Zin *et al.*, 2004)) is used in this simulation. The considered parameters for the controller design are $m_s = 315$ kg, $m_{us} = 37.5$ kg, $k_s = 29500$ N/m, $k_t = 210000$ N/m. The damper model parameters have been chosen according to the MR damper model (as in (Nino-Juarez *et al.*, 2008)): $a_2 = 800$ Ns/m, $a_3 = 129$ s/m, $v_0 = 0.788 \times 10^{-3}$ m/s, $x_0 = 1.195 \times 10^{-3}$ m, $F_0 = 250$ N. In the sequel, the different cases are considered for the performance evaluation of the proposed methodology:

- Passive = Renault Mégane Car equipped with an optimized passive damper.
- Nominal = Renault Mégane Car equipped with a nominal MR damper (not controlled, $a_1 = (a_{1max} + a_{1min})/2$).

- LPV/H_∞ = Renault Mégane Car equipped with a semi-active damper controlled by the proposed methodology.

As seen in Fig. 3, the "frequency response" \ddot{z}_s/z_r in the LPV/H_∞ case is better than that in passive case in [0-9] Hz allowing to improve the passenger comfort. z_s/z_r is also improved in [0-7.5] Hz and z_{def}/z_r is slightly degraded. An interesting result is also that the frequency response z_{us}/z_r in the LPV/H_∞ case is slightly better than that in passive case in most of the frequency range. So the road holding capacity is also improved.

In the time domain simulation, z_r is a uniformly distributed random signal with a magnitude between [-2.0 cm ; 2.0 cm] and a 1s period. As seen in (Fig. 4), the input force u remains in the range [-250 ; +250] N so the dissipativity constraint is satisfied. By comparison with the passive case, the vehicle acceleration \ddot{z}_s and the vehicle travel z_s in LPV/H_∞ case have a better shape. ρ_1 and ρ_2 mostly vary for significant changes of z_r .

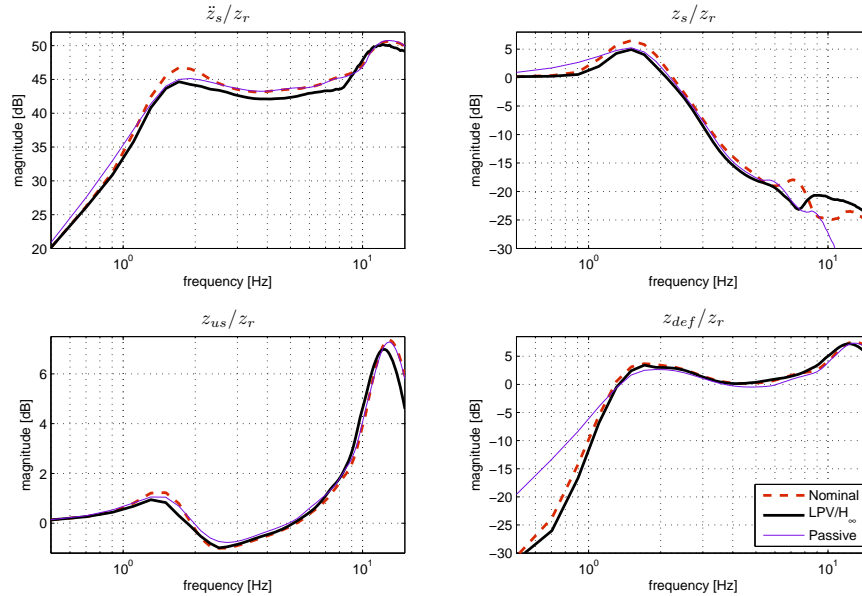

Figure 3. Nonlinear frequency responses (Pseudo-Bode).

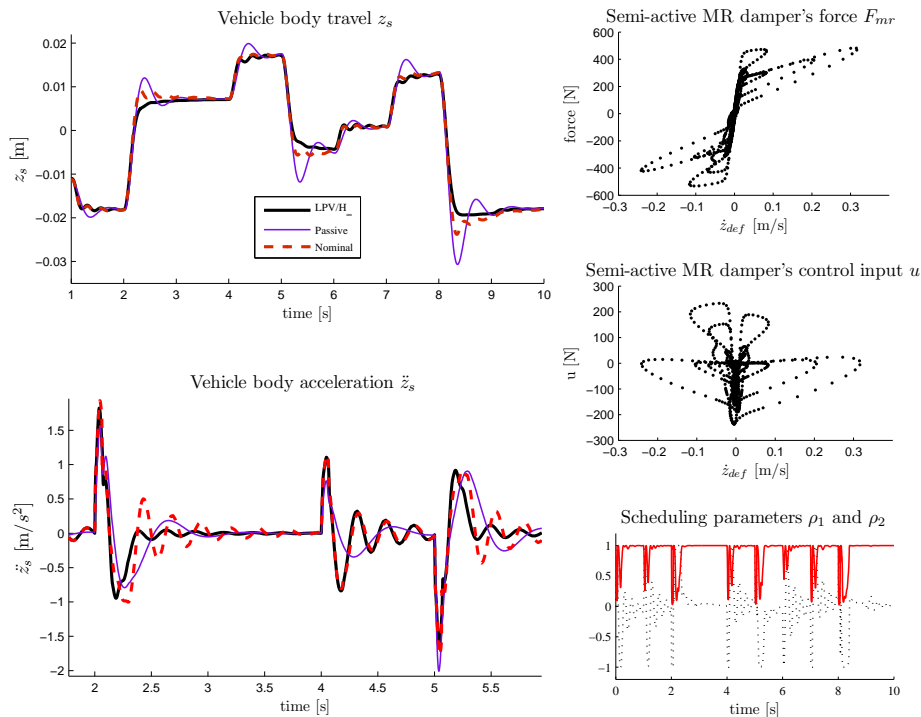

Figure 4. Time responses.

5. CONCLUSION

In this paper, a new method for semi-active suspension control has been proposed. An LPV model for a quarter vehicle with an MR damper is formulated and an LPV controller is synthesized to improve the driving comfort while maintaining the road holding capacity. The simulation results in the frequency and time domains have shown that the performance objectives can be reached while satisfying the dissipativity constraint for some road profiles. Future works will concern the solution of the theoretical problem of actuator saturation (or dissipativity constraint). Besides, to enhance the performance, the reduction of the conservatism in controller design, which mainly concerns the self-dependence of scheduling parameters, will be also considered. The variation of the MR damper parameters (a_3 , v_0 , x_0 and specially a_2) will be taken into account so that the controller better copes with real applications.

6. REFERENCES

- Ag, C. (2003). Global chassis control - integration of chassis systems. *Automatisierungstechnik*, **51**, 300–312.
- Apkarian, P. & Gahinet, P. (1995). A convex characterization of gain scheduled \mathcal{H}_∞ controllers. *IEEE Transaction on Automatic Control*, **40**, 853–864.
- Baslamisli, S., Köse, I. & Anlas, G. (2007). Robust control of anti-lock brake system. *Vehicle System Dynamics*, **45**, 217–232.
- Guo, S., Yang, S. & Pan, C. (2006). Dynamic modeling of magnetorheological damper behaviors. *Journal of Intelligent Material Systems And Structures*, **17**, 3–14.
- Hac, A. (2002). Rollover stability index including effects of suspension design. *SAE Trans.*, **2002-01-0965**.
- Jager, B.D. (1997). Robust \mathcal{H}_2 optimal control of an active suspension. In *Proceedings of the 1997 IEEE International Conference on Control Applications*, 761–766, Hartford.
- Nino-Juarez, E., Morales-Menendez, R., Ramirez-Mendoza, R. & Dugard, L. (2008). Minimizing the frequency in a black box model of a mr damper. In *11th Mini Conf on Vehicle Sys. Dyn., Ident. and Anomalies*, Budapest, Hungary.
- Poussot-Vassal, C. (2008). *Robust Multivariable Linear Parameter Varying Automotive Global Chassis Control*. PhD thesis (in english), Grenoble INP, GIPSA-lab, Control System dpt., Grenoble, France.
- Poussot-Vassal, C., Sename, O., Dugard, L., Ramirez-Mendoza, R. & Flores, L. (2006). Optimal Skyhook control for semi-active suspensions. In *Proceedings of the 4th IFAC Symposium on Mechatronics Systems*, 608–613, Heidelberg, Germany.
- Poussot-Vassal, C., Sename, O., Dugard, L., Gáspár, P., Szabó, Z. & Bokor, J. (2008). New semi-active suspension control strategy through LPV technique. *Control Engineering Practice*, **16**, 1519–1534.
- Sammier, D., Sename, O. & Dugard, L. (2003). Skyhook and \mathcal{H}_∞ control of active vehicle suspensions: some practical aspects. *Vehicle System Dynamics*, **39**, 279–308.
- Savaresi, S. & Spelta, C. (2007). Mixed sky-hook and ADD: Approaching the filtering limits of a semi-active suspension. *ASME Transactions: Journal of Dynamic Systems, Measurement and Control*, **129**, 382–392.
- Savaresi, S., Tanelli, M. & Cantoni, C. (2007). Mixed slip-deceleration control in automotive braking systems. *ASME Transactions: Journal of Dynamic Systems, Measurement and Control*, **129**, 20–31.
- Scherer, C., Gahinet, P. & Chilali, M. (1997). Multiobjective output-feedback control via LMI optimization. *IEEE Transaction on Automatic Control*, **42**, 896–911.
- Zin, A. (2005). *Robust automotive suspension control toward global chassis control*. PhD thesis (in french), INPG, Laboratoire d'Automatique de Grenoble (new GIPSA-lab), Grenoble, France.
- Zin, A., Sename, O., Basset, M., Dugard, L. & Gissinger, G. (2004). A nonlinear vehicle bicycle model for suspension and handling control studies. In *Proceedings of the IFAC Conference on Advances in Vehicle Control and Safety (AVCS)*, 638–643, Genova, Italy.

7. RESPONSIBILITY NOTICE

The authors are the only responsible for the printed material included in this paper