



HAL
open science

The glycosylation of human synovial lubricin: implications for its role in inflammation

Ruby P. Estrella, John M Whitelock, Nicolle H. Packer, Niclas G Karlsson

► To cite this version:

Ruby P. Estrella, John M Whitelock, Nicolle H. Packer, Niclas G Karlsson. The glycosylation of human synovial lubricin: implications for its role in inflammation. *Biochemical Journal*, 2010, 429 (2), pp.359-367. 10.1042/BJ20100360 . hal-00495493

HAL Id: hal-00495493

<https://hal.science/hal-00495493>

Submitted on 28 Jun 2010

HAL is a multi-disciplinary open access archive for the deposit and dissemination of scientific research documents, whether they are published or not. The documents may come from teaching and research institutions in France or abroad, or from public or private research centers.

L'archive ouverte pluridisciplinaire **HAL**, est destinée au dépôt et à la diffusion de documents scientifiques de niveau recherche, publiés ou non, émanant des établissements d'enseignement et de recherche français ou étrangers, des laboratoires publics ou privés.

The glycosylation of human synovial lubricin: implications for its role in inflammation

Ruby P. ESTRELLA^{*}, John M. WHITELOCK^{*}, Nicolle H. PACKER[†] and Niclas G. KARLSSON^{‡1}

^{*} Graduate School of Biomedical Engineering, University of New South Wales, Sydney NSW 2052 Australia

[†] Department of Chemistry and Biomolecular Sciences, Biomolecular Frontiers Research Centre, Macquarie University, Sydney, NSW 2109, Australia

[‡] Medical Biochemistry, University of Gothenburg, Gothenburg, Sweden

¹To whom correspondence should be addressed; Niclas Karlsson, Medical Biochemistry, University of Gothenburg, P.O. Box 440, 405 30 Gothenburg, Sweden, Phone +46 31 7866528, Fax +46 31 416108, email niclas.karlsson@medkem.gu.se

SYNOPSIS

Acidic proteins were isolated from synovial fluid from two osteoarthritic and two rheumatoid arthritic patients and identified by mass spectrometry. It was found that the most abundant protein in all the samples was the mucin-like protein lubricin. Further characterization of lubricin from the different patients by liquid chromatography-mass spectrometry of released oligosaccharides showed that the core 1 *O*-linked oligosaccharides NeuAc α 2-3Gal β 1-3GalNAc and NeuAc α 2-3Gal β 1-3(NeuAc α 2-6)GalNAc were the dominating structures on lubricin. The latter was found to be more prevalent in the rheumatoid arthritis samples, indicating that sialylation is up-regulated as part of the inflammatory response. In addition to these dominating structures, core 2 structures were also found in low amounts, where the largest was the disialylated hexasaccharide corresponding to the sequence NeuAc α 2-3Gal β 1-3(NeuAc α 2-3Gal β 1-3/4GlcNAc β 1-6)GalNAc. It was also found that a small proportion of the core 2 oligosaccharides carried sulfate. The ability of lubricin to present complex glycosylation reflecting the state of the joint tissue makes lubricin a candidate as a carrier of inflammatory oligosaccharide epitopes. In particular, it was shown that lubricin from inflamed arthritic tissue was recognized by the antibody MECA-79 and thus carried the sulfated epitope proposed to be part of the L-selectin ligand that is responsible for recruitment of leukocytes to inflammatory sites.

Short title: Sulfation and Sialylation of lubricin

Keywords: lubricin, MECA-79, inflammation L-selectin, Mass spectrometry, glycosylation

Abbreviations used: HEV, high endothelial venules; HRP, horse radish peroxidase; PRG4, proteoglycan 4; OA, osteoarthritis; PNA, Peanut Agglutinin *Arachis hypogea*; RA, rheumatoid arthritis; SF, synovial fluid; TBS, tris buffered saline; TBST, Tris buffered Saline 0.01% Tween; Tricine, *N*-tris(hydroxymethyl)methylglycine; Tris, *tris*(hydroxymethyl)aminomethane;

INTRODUCTION

Lubricin is a mucin-like molecule encoded by the PRG4 (proteoglycan 4) gene. The protein, also known by the name megakaryocyte stimulating factor[1] and superficial zone protein[2], consists of an approximately 1400 residue apoprotein with a 500 amino acid mucin domain containing 59 imperfectly repeated sequences of KEPATTP. This domain is flanked by a C terminal hemopexin domain and two somatomedin domains at the N-terminal. The synovial variant of lubricin is secreted by multiple cell types present in the articular cartilage[2], the meniscus[3] the synovial lining [4] and the tendon[5]. The name lubricin highlights the functional aspect of the protein with regards to lubrication and chondroprotection, as demonstrated by the PRG4 gene knockout mice model which displays hyperplastic synovium and cartilage deterioration with both leading to joint failure[6].

The earliest characterization of lubricin was through the work of Swann *et al* and colleagues where it was found to be the lubricating component of synovial fluid(SF)[4, 7], and was comprised of 40% (w/w) of carbohydrate, predominantly consisting of Gal, GalNAc, and NeuAc [7-10]. The presence of mucin-type core 1 oligosaccharides with or without sialic acid has been confirmed on lubricin[11], but not much else is known about its glycosylation. Whilst the name proteoglycan 4 indicates that lubricin is a proteoglycan, the evidence for this is either circumstantial or speculative based on an altered migration of bovine lubricin in gel chromatography after chondroitinase ABC digestion[2] and the presence of a single putative CS consensus attachment sequence, DEAGSG, at AA 210-215 [12-14].

Lubricin has mucin-type properties such as the presence of a mucin domain (high content of proline, serine and threonine)that provides a scaffold for glycosylation, which affect its physical properties such as high viscosity and low friction. In addition, it has recently been shown that lubricin molecules are capable of forming intramolecular disulfide bridges, similar to the gel forming mucins such as MUC2, MUC5B, MUC5AC and MUC6[15]. In the case of lubricin, this reaction appears to be limited to generating dimers of lubricin[16], while in the case of some mucins, multimers are generated [17].

The main arthritic diseases of the joint, OA (osteoarthritis) and RA (rheumatoid arthritis), cause a considerable amount of pain and disability to those affected. Current treatment regimens have limited efficacy, therefore it is imperative to understand the biochemical factors related to these diseases in order to assist in early diagnosis and development of prevention and treatment strategies. Whilst OA and RA are very different in pathological etiology and disease manifestation, a common symptom is cartilage degeneration that can be detected by the deposition of proteoglycan fragments into the SF. This nutritious fluid, produced mainly by the synoviocytes in the synovium, provides lubrication and nourishment via the secretion of growth factors, cytokines, proteoglycans and hyaluronic acid to the neighboring articular cartilage. In addition, SF also contains a plethora of other components ranging from protease degradation products of cartilage extracellular matrix components such as cartilage oligomeric matrix protein, type II collagen, and aggrecan [18-19] to the influx of inflammatory markers and immune cells. With inflammation of the

synovium being the significant difference in the disease manifestation between OA and RA, the development of HEV (high endothelial venules) in RA provide the mechanism for recruitment of macrophages and leukocytes to the inflamed tissue. With the upregulation of the HEV specific sulfotransferase [20] and potentially other alterations to the glycosylation machinery due to inflammation of the synovium, mining the SF for the secreted glycoproteome from joint tissue is likely to provide insight into the mechanisms of progression of RA compared to the non-inflammatory OA. In this study, acidic glycoproteins, including lubricin, were enriched from SF by DEAE anion exchange chromatography and separated by SDS-PAGE. Proteomic and glycomic analysis were carried out by LC-MS after tryptic digestion and after release of *O*-linked oligosaccharides, respectively. The aim of this study was to determine the main acidic SF glycoproteins present in OA and RA pathology and examine the changes in glycoprotein structure that may be indicative of disease.

EXPERIMENTAL

Chemicals were purchased from Sigma-Aldrich (St Louis, MO) of highest analytical grade if not stated otherwise.

Enrichment of acidic proteins from SF

Human SF samples (2 each from OA and RA patients) were obtained through Professor Nagata from Kurume University Hospital, Japan. All samples were stored at -70°C until use. SF samples were thawed quickly prior to use and diluted 1/10 in starting buffer consisting of 250mM NaCl, 20mM Tris (tris(hydroxymethyl)aminomethane)-HCl, 10mM EDTA (pH 7.5) and 0.01% (w/v) protease inhibitor cocktail (Sigma-Aldrich). The proteoglycan containing fractions were isolated by anion exchange chromatography[21] using a VP HPLC System (Shimadzu Corporation, Kyoto Japan) and a 1 mL DEAE FF Hi-trap column (GE Biosciences, Uppsala, Sweden). The acidic protein fraction was eluted with 1M NaCl, 20mM Tris, 10mM EDTA pH 7.5 and precipitated with 80% ethanol for 16 h at -20°C . The precipitate was collected after centrifugation at 4000g for 30 min and air-dried.

Gel Electrophoresis

Ethanol-precipitated pellets were reconstituted in 0.75 M Tris HCl at pH 8.1, 20%(v/v) glycerol, 2% (w/v) SDS and 0.01% (w/v) bromophenol blue and concentrated using YM-100 Microcon filters (Millipore, Bedford, MA). Samples were reduced with 10mM dithioereitol (Sigma-Aldrich) to 95°C for 20 min, alkylated with 25mM iodoacetamide (1 h) and applied to 3-8% Tris Acetate Gel (Nu-PAGE, Invitrogen, Carlsbad CA USA) electrophoresed at 30mA per gel using Tricine (*N*-tris(hydroxymethyl) methylglycine) SDS running buffer (100mM Tris base pH 8.5, 100mM Tricine, 0.1% (w/v) SDS, pH 8.3). The gels were immersed in a solution of Coomassie Blue G250 (0.1% (w/v) Coomassie Brilliant Blue G250, 2% (v/v) phosphoric acid, 10% (w/v) ammonium sulfate, 20% (v/v) methanol) or Alcian Blue (0.125% (w/v) Alcian Blue, 25% (v/v) ethanol, 10% (v/v) acetic acid) and incubated at ambient temperature for 16 h on a plate shaker and destained in 50% (v/v) methanol or in 25%(v/v) ethanol with 10% (v/v) acetic acid. For Western and lectin

blotting the gels were transferred onto Immobilon P membranes, (Millipore) using an ElectrophoretIQ™ semi-dry blotter (Proteome Systems Ltd. North Ryde, Sydney Australia) [22].

Enzymatic deglycosylation of lubricin

A psoriatic arthritic patient SF sample was obtained through Dr. Peter Youssef and Ms. Dot Fowler of the Department of Rheumatology, Royal Prince Alfred Hospital, Sydney, Australia. Acidic proteins was isolated as described above and dissolved in 50 mM sodium phosphate (pH 6.0). The samples (14 μ L aliquots) were treated with 10 mU sialidase A (Prozyme, San Leandro, CA) and 2.5 mU *O*-glycanase at 37°C for 16 hours. The reaction was stopped by adding SDS-PAGE sample buffer described above with 10 mM dithiothreitol and denatured at 95°C for 5 min before subjecting the samples to SDS-PAGE.

Antibody and Lectin staining

Proteins blotted onto Immobilon P membranes were blocked for 1-16 h at 4°C in 1% BSA-TBST buffer (1% (w/v) BSA with Tris buffered Saline 0.01% (w/v) Tween), and then incubated with primary antibodies or biotinylated lectins at the appropriate concentration diluted in 1% BSA-TBST for 16 h at 4°C. Blots were washed 3 times 10 min with TBST and incubated for 1 h at ambient temperature with secondary antibody or streptavidin labeled with HRP (horse radish peroxidase). After three washes with TBST as above, excess Tween was removed by 3 additional washes in TBS. Antibody and lectin binding were detected using Super Signal West Femto luminal enhancer solutions and stable peroxide buffers (Pierce Biotechnology, Rockford IL USA). The primary antibodies used were anti-Lubricin antibody 378 (0.01mg/mL a generous gift from Drs. Carl Flannery and Aled Jones of Wyeth, Cambridge, MA USA), anti-MECA-79 (1 μ g/mL, Roche Diagnostics, Mannheim Germany), anti-sialyl Lewis X (CSLEX1, 1 μ g/mL, BD Biosciences, San Jose, CA), Peanut Agglutinin *Arachis hypogea* PNA lectin (Peanut Agglutinin *Arachis hypogea*, detecting Gal β 1-3GalNAc, 1 μ g/mL, Vector Labs, Burlingame, CA). Secondary antibodies used were HRP Anti mouse IgG (1/50,000, Chemicon, Temecula, CA) and HRP Anti rat Ig (1/50,000, GE Healthcare) and for lectin detection HRP streptavidin (1 μ g/mL, Sigma-Aldrich).

Protein identification

Coomassie stained protein bands in SDS-PAGE gels were excised and placed into wells of a 96-well microtitre plate. After repeated destaining (50% (v/v) acetonitrile and 50 mM NH₄HCO₃) the gel pieces were washed with 100% acetonitrile and dried in oven. Trypsin (15 μ L, sequencing grade modified, Promega, Madison WI) at a final concentration of 20ng/ μ L in 50mM NH₄HCO₃ was added and the plate was sealed and incubated at 30°C for 16 h. After digestion, 10 μ L of 50mM NH₄HCO₃ was added and the wells sonicated for 5 min. This process was repeated 3 times and each sample was transferred to a new microtitre plate and dried down to 10 μ L. Peptides were analysed by nano LC-MS using an LCQ-DECA XP mass spectrometer (Thermo Scientific, San Jose, CA)[23] and proteins identified by SEQUEST using SwissProt/Tremble and NCBI (Homo sapiens, 2005 version). Positive protein

matches were assigned according to the criteria of at least 2 peptide sequences with manual inspection of tandem mass spectra showing at least 4 consecutive *b* or *y* overlapping ions, an $X_{corr} > 2.0$ and a $\Delta C_n > 0.1$ [24].

Oligosaccharide Characterization

O-linked oligosaccharides were released by reductive β -elimination from the Alcian blue stained bands corresponding to the area where lubricin was detected. Bands were excised and dehydrated in a vacuum centrifuge (Eppendorf, Hamburg Germany). Once dried, 50 μ L of 1.0 M NaBH_4 in 100 mM NaOH was added to cover the entire gel piece and incubated for 16 hours at 50°C. Reactions were quenched with 1.0 μ L of glacial acetic acid, samples desalted and dried for capillary graphitized carbon LC-MS and LC-MS² in negative ion mode [22]. Oligosaccharides were identified from their MS² spectra using the GlycoMIQ module of GlycosuiteDB (August 2005, version 8.0, Proteome Systems) (Joshi et al. 2004). GlycoWorkbench (version 1.0.3110, May 2008) was used for symbolic notation of oligosaccharides [25].

RESULTS

Identification of lubricin as the major acidic protein in human SF

Proteoglycans are acidic proteins in synovial fluid (SF) that are believed to be important components which sustain lubrication and protect the cartilage in synovial joints. In order to compare the acidic glycoproteins from OA and RA patients, the retained proteoglycan containing fraction of proteins separated by DEAE anion exchange chromatography from each SF sample were collected [21] (Fig. 1A). Based on the UV response compared to the flow through, it was suggested that the acidic proteins only made up less than 2% of the total protein content in SF, and there was no apparent difference detected between OA and RA patients.

SDS-PAGE showed that all samples displayed a major component with an apparent molecular mass of approximately 350 kDa, stained with Coomassie blue (protein) (Figure 1B) and Alcian blue (acidic oligosaccharides) (Figure 1C). The latter indicates the presence of acidic type oligosaccharides and/or sulfated GAGs on this major glycoprotein. There appeared to be no other major distinct bands that stained with Alcian blue in any of the samples (Figure 1C), while the Coomassie staining showed that other acidic proteins were present in low abundance.

Individual bands were excised from the Coomassie stained SDS-PAGE bands and subjected to tryptic digestion and subsequent identification of proteins using LC-MS² (Table 1 and supplementary material). The main Coomassie and Alcian blue stained glycoprotein detected in the approximately 350 kDa band was identified as lubricin, also known as megakaryocyte stimulating factor, superficial zone protein or Proteoglycan 4 and is a mucin-like glycoprotein. This finding was consistent with an earlier characterization where it was shown to be a 345 kDa glycoprotein from cartilage extracts [2]. Only 6-10% (19-32% if the indigestible mucin domain is excluded) of predicted lubricin peptides were detected by LC-MS (Table 1), predominantly from the C-terminus of the protein core. This low coverage is consistent with mucin type molecules where the large mucin domain (tandem repeat sequence of KEPAPPTT in lubricin) generates a large heterogeneously glycosylated

peptide impossible to analyze with conventional LC-MS/MS protein identification approaches. Sequences found in all 4 samples involved predominantly regions of exons 6-7, 8 and 10, and a peptide from the *N*-terminal exon 3 was found in the samples with the highest abundance of lubricin (Table 1), indicating that full length lubricin was present in these preparations. Using antibody 378 against anti-lubricin exon 3, it was confirmed that the lubricin identified from all OA and RA patients contained the *N*-terminal in addition to the *C*-terminal detected by LC-MS² (Figure 1D). The samples with the highest lubricin load (OA2 and RA2), showed additional bands at the 250 kDa and in the low mass region 37-75 kDa confirming that human lubricin may undergo post translational modifications and cleavages. The lower identified fragments are potentially from the *N*-terminal region generated by a subtilisin-like enzyme, which are thought to occur as part of normal processing/turnover of lubricin [6]. These *N*-terminal region fragments appear to be at low abundance, since they were not identified by LC-MS² and were only visible by antibody staining indicating that little cleavage is occurring, compared to the major component of full length lubricin at 350 kDa.

LC-MS² analysis of the Coomassie blue stained gels confirmed that additional acidic proteins, including proteoglycans such as versican, aggrecan and lumican were also present in SF (Table 1). The commonality of these detected proteoglycans is that they all contain repeat sequences with oligosaccharides attached either as CS, KS or small *O*-linked structures, making them highly acidic and retained by the anion exchange column. For a full list of proteins detected in the acidic fraction of SF see Supplementary material.

Identification of two forms of lubricin after sialidase/*O*-glycanase treatment

Since lubricin previously has been shown to contain core 1 *O*-linked structures with one or two additional sialic acids attached, the treatment of a combination of sialidase and *O*-glycanase should significantly lower the apparent molecular mass of lubricin in SDS-PAGE. The extensive sialylation of lubricin was confirmed by sialidase treatment of lubricin which was then found as a disperse band about 70kDa less than the untreated sample (Figure 2a). Sialidase treatment concomitantly exposed core 1 disaccharides of the *O*-linked structures on lubricin as detected by peanut agglutinin lectin (Figure 2b). Further digestion with *O*-glycanase abolished the peanut agglutinin reaction and two lubricin bands estimated to be 225 and 250 kDa were detected. Using these approximate mass changes the *O*-linked oligosaccharides can be estimated to comprise about 30-35% of the total molecular weight of lubricin, thus highlighting their significant contribution to the structure of lubricin. The presence of two isoforms of lubricin after the digestions indicated that the sialidase/*O*-glycanase treatment may not have removed all *O*-linked structures.

Mass spectrometric analysis of *O*-linked oligosaccharides present on lubricin from OA and RA patients

In order to determine if there were more complex *O*-linked oligosaccharides present on lubricin, the *O*-linked oligosaccharides were released from the SDS-PAGE separated protein by reductive β -elimination and analyzed by negative ion graphitized carbon LC-MS and LC-MS². The dominating structures in all the samples (90-95%

of the total ion count of detected oligosaccharides) were the monosialylated and disialylated core 1 structures with sequences corresponding to Neu5Ac α 2-3Gal β 1-3GalNAc (detected as an alditol with $[M - H]^-$ -ion of m/z 675) and Neu5Ac α 2-3Gal β 1-3(Neu5Ac α 2-6)GalNAc (detected as an alditol with $[M - H]^-$ -ion of m/z 966) (Table 2 and Figure 3). A small amount of an isomeric form of the monosialylated core 1 structure corresponding to the structure Gal β 1-3(Neu5Ac α 2-6)GalNAc in one of the samples (OA2) was also detected (Table 2). The reported un-sialylated structure Gal β 1-3GalNAc was only detected by PNA lectin blotting (Figure 2) as it was not retained by the graphitized carbon column of the LC-MS.

Thus all samples of lubricin contained the four core 1 structures previously suggested [11]. Interestingly, the lubricin isolated from the SF of the OA patients showed a higher relative intensity of the monosialylated species compared to the disialylated (Figure 3 and Table 2). This suggests that the inflammatory stress of RA may influence the sialylation of lubricin and implicates an increased activity of the α 2,6 sialyltransferase. Without having access to healthy control samples, speculation of disease related alterations of sialyltransferase activity in RA and OA can not be made.

In addition to the core 1 structures it was also found that the lubricin oligosaccharides could be extended further into core 2 structures which were seen at low abundance (Table 2). All the samples, 4-8% of the total ion count of the detected oligosaccharides corresponded to a sequence corresponding to Neu5Ac α 2-3Gal β 1-3(Neu5Ac α 2-3Gal β 1-4/(3)GlcNAc β 1-6)GalNAc (detected as an alditol with $[M - H]^-$ -ion of m/z 1331). In the samples with a higher protein concentration core 2 oligosaccharides were also found corresponding to biosynthetic precursors of this disialylated hexasaccharide ($[M - H]^-$ -ions of m/z 74 and m/z 1040; Table 2). The detection of two isomers of the $[M - H]^-$ -ions of m/z 1040 shows that both isomers corresponding to the sequences Neu5Ac α 2-3Gal β 1-3(Gal β 1-4/(3)GlcNAc β 1-6)GalNAc and to Gal β 1-3(Neu5Ac α 2-3Gal β 1-4/(3)GlcNAc β 1-6)GalNAc are present on lubricin.

There were also low abundant ions with masses corresponding to sulfated *O*-linked core 2 oligosaccharides in the OA2 sample (Table 2). The MS² spectra of the $[M - H]^-$ -ions of m/z 829 and m/z 1120 (Figure 4) confirmed that they were monosulfated oligosaccharides with and without sialylation respectively. The low intensities of these ions meant that only limited structural information could be obtained on the linkage of these structures. With the presence of other core 2 structures in the samples it could be speculated that the detected ions corresponded to sulfated versions of the core 2 structure Gal β 1-3(Gal β 1-3/4GlcNAc β 1-6)GalNAc. The addition of sialic acid to the higher mass parent ion is consistent with the MS² spectrum (Figure 4b), where the dominating fragment ion (m/z 829) is the loss of the sialic acid mass of m/z 291.

Oligosaccharides on synovial lubricin express MECA-79 epitope in psoriatic arthritis.

Sulfated ligands (via up-regulation of HEV specific 6-sulfotransferase[20, 26]) has been shown to mediate L-selectin leukocyte rolling. Therefore, an arthritic SF sample was probed with the MECA-79 antibody (specific to part of the L-selectin epitope) by Western blotting (Figure 5). This showed that the lubricin containing band was

MECA-79 positive. However, using an antibody against sialyl Lewis x (specific to the fucosylated part of the structure of the L-selectin epitope), there was no staining of lubricin band. This is consistent with the type of oligosaccharides on lubricin detected by mass spectrometry in the previous paragraph, since no fucosylated structures were detected. The data indicate that while the MECA-79 epitope is indeed present on lubricin, it does not contain the full ligand for L-selectin (reported to be 6 sulfo sialyl Lewis x) [27]. Hence, the MECA-79 epitope and sulfotransferase may have a function in arthritic inflammation different to just the recruitment of leucocytes to the area of inflammation.

DISCUSSION

The identification of lubricin as the most dominant component amongst the acidic glycoprotein and proteoglycan fraction in SF was unexpected, as current arthritic biomarker research have been focused on the detection of the glycosaminoglycan and protein content of proteoglycans such as aggrecan. With the knowledge that lubricin is important for joint lubrication, it is tempting to speculate about the significance of the finding of lubricin as a major SF constituent. As a boundary lubricant covering the cartilage surface, one of the first stages of arthritic disease involves the compromised integrity of cartilage through fibrillation of the cartilage surface[28].

Chondroprotection is one of the functions of lubricin and therefore the changes and loss of lubricin at the cartilage surface could occur before the loss of aggrecan, collagen and other components from the cartilage extracellular matrix just below the lamina splendens. Thus lubricin in diseased SF could be a mixed population of secreted lubricin molecules, and detached lubricin that were previously associated with cartilage and synovium surfaces.

Mass spectrometric analysis of the glycosylation of lubricin has revealed that there are at least 9 different of *O*-linked oligosaccharides residing on lubricin, including disialylated core 1, disialylated core 2 and sulfated core 2 oligosaccharides. Previous descriptions of lubricin glycosylation have been performed describing only a core 1 disaccharide and sialylated trisaccharide [11]. This study offers a more sensitive and detailed description of *O*-linked oligosaccharide structures on lubricin with the use of analysis of the released oligosaccharides by graphitized carbon LC- MS. The higher proportion of the disialylated tetrasaccharide compared to the singly sialylated trisaccharide in RA samples compared to OA samples has biosynthetic consequences. The disialylated structure NeuAca α 2-3Gal β 1-3(NeuAca α 2-6)GalNAc is considered to be a “dead-end” structure because it cannot be modified any further by glycosyltransferases in the Golgi [29]. Presence of increased amounts of sialylated structures suggest a shift towards higher expression levels of sialyltransferases, which can shunt the biosynthetic pathway away from core 2 oligosaccharide biosynthesis towards oligosaccharide extension termination (Figure 6). This shift towards core 1 synthesis would lead to shorter and less diverse oligosaccharides, which would dominate the overall glycosylation profile. Considering the results in the base peak LC-MS (Figure 3 and Table 2), there were fewer oligosaccharide types and shorter structures in the RA samples compared to the OA samples. In addition, more than half of the total oligosaccharide population in the RA samples was composed of the disialylated core 1 oligosaccharide. This change to a less complex type of *O*- linked glycosylation is a hallmark of human malignant states such as cancer and

inflammation, in which mucins from diseased tissues exhibited higher sialylation compared to mucins from normal tissues [30]. Altered sialylation is also shown to occur in other glycoproteins in RA such as fibronectin [31] and IgG [32]. In the case of the latter molecule it has been speculated that sialylation on the Fc portion of IgG may lead to a protective and anti-inflammatory effect on the autoantibody pathology in RA [33]. Increase of disialylated structures can increase the negative charge density within the glycosylated domains in lubricin and thus can also have other functional implications. Other researchers have shown that lubrication is not totally dependent on sialic acid and that its removal did not impair lubrication [11]. However, if there is relatively more sialic acid residues, lubrication may be enhanced through an increase of repellent charge forces due to the increase in negative charge around lubricin [34-36]. Thus, in the RA, increased sialylated lubricin may be a response to combat disease progression by increasing the lubricating ability of lubricin on cartilage surfaces, or in OA the decrease of sialylation may impair the lubrication and exacerbate the disease. The validation of this speculation on the effects of altered sialylation is currently under investigation in our laboratory.

The detection of the sulfated core 2 oligosaccharides in OA may be a result of the regulation of the α 2,6 sialyltransferase reflected in the increased sialylation of core 1 oligosaccharides seen in RA compared to OA (Figure 3). A down regulation of this sialyltransferase would allow more core 1 oligosaccharides to be extended into core 2 oligosaccharides in OA, which could then be sulfated (Figure 6). Sulfated *O*-linked oligosaccharides have been shown to have roles in cell signaling, adhesion and inflammation and our finding of sulfated epitopes on lubricin will lead to further investigation into the presence of such sulfated oligosaccharide epitopes on lubricin as markers for inflammatory conditions.

It was also found that the epitope MECA-79 (but not sialyl Lewis x) is carried by lubricin. MECA-79 is a subset of the L-selectin ligand structure with a minimum requirement for MECA-79 binding as GlcNAc-6S [27]. Fucosylation of L-selectin ligands regulates leukocyte rolling along endothelial cell surfaces [37] and thus the fucosylated sialyl Lewis x L-selectin structures align the path from lymph nodes and blood vessels to help leukocytes travel to the localized sites of inflammation [38]. The function of sulfation of oligosaccharides in inflammation is unknown and the non-fucosylated sulfated oligosaccharide structure exhibited by lubricin may be unique to inflammation of the joint tissues. Further functional studies are needed and are being carried out to determine the functional importance of this modification in arthritis.

ACKNOWLEDGEMENTS

Dr. Peter Youssef and Ms. Dot Fowler of the Department of Rheumatology, Royal Prince Alfred Hospital, Sydney, Australia and Professor Kensei Nagata from Kurume University Hospital, Japan are gratefully acknowledged for providing SF samples from their clinics. Drs. Carl Flannery and Aled Jones of Wyeth, Cambridge, MA USA are acknowledged for their generous gift of the lubricin 378 antibody.

FUNDING

We would like to acknowledge the generous support of the Australian Government

for funding through the Australian Research Council Linkage Grants Scheme (LP0445407) and Proteome Systems Pty Ltd (now Tyrian Diagnostics Pty Ltd, Sydney, Australia). This study was in part funded by an EU Marie Curie Program grants (no. PIRG-GA-2007- 205302)

REFERENCES

- 1 Merberg, D. M., Fitz, L. J., Temple, P., Giannotti, J., Murtha, P., Fitzgerald, M., Scaltreto, H., Kelleher, K., Preissner, K., Kriz, R., Jacobs, K. and Turner, K. (1993) A Comparison of Vitronectin and Megakaryocyte Stimulating Factor. In *Biology of Vitronectins and Their Receptors*. (Preissner, K. T., Rosenblatt, S., Kost, C., Wegerhoff, J. and Mosher, D. F., eds.). pp. 45-52, Elsevier Science BV, Amsterdam
- 2 Schumacher, B. L., Block, J. A., Schmid, T. M., Aydelotte, M. B. and Kuettner, K. E. (1994) A novel proteoglycan synthesized and secreted by chondrocytes of the superficial zone of articular cartilage. *Arch. Biochem. Biophys.* **311**, 144-152
- 3 Schumacher, B. L., Schmidt, T. A., Voegtline, M. S., Chen, A. C. and Sah, R. L. (2005) Proteoglycan 4 (PRG4) synthesis and immunolocalization in bovine meniscus. *J. Orthop. Res.* **23**, 562-568
- 4 Radin, E. L., Swann, D. A. and Weisser, P. A. (1970) Separation of a hyaluronate-free lubricating fraction from synovial fluid. *Nature* **228**, 377-378
- 5 Rees, S. G., Davies, J. R., Tudor, D., Flannery, C. R., Hughes, C. E., Dent, C. M. and Caterson, B. (2002) Immunolocalisation and expression of proteoglycan 4 (cartilage superficial zone proteoglycan) in tendon. *Matrix Biol.* **21**, 593-602
- 6 Rhee, D. K., Marcelino, J., Baker, M., Gong, Y., Smits, P., Lefebvre, V., Jay, G. D., Stewart, M., Wang, H., Warman, M. L. and Carpten, J. D. (2005) The secreted glycoprotein lubricin protects cartilage surfaces and inhibits synovial cell overgrowth. *J. Clin. Invest.* **115**, 622-631
- 7 Swann, D. A., Sotman, S., Dixon, M. and Brooks, C. (1977) The isolation and partial characterization of the major glycoprotein (LGP-I) from the articular lubricating fraction from bovine synovial fluid. *Biochem. J.* **161**, 473-485
- 8 Garg, H. G., Swann, D. A. and Glasgow, L. R. (1979) The structure of the O-glycosylally-linked oligosaccharide chains of LPG-I, a glycoprotein present in articular lubricating fraction of bovine synovial fluid. *Carbohydr. Res.* **78**, 79-88
- 9 Swann, D. A., Silver, F. H., Slayter, H. S., Stafford, W. and Shore, E. (1985) The molecular structure and lubricating activity of lubricin isolated from bovine and human synovial fluids. *Biochem. J.* **225**, 195-201
- 10 Swann, D. A., Slayter, H. S. and Silver, F. H. (1981) The molecular structure of lubricating glycoprotein-I, the boundary lubricant for articular cartilage. *J. Biol. Chem.* **256**, 5921-5925
- 11 Jay, G. D., Harris, D. A. and Cha, C. J. (2001) Boundary lubrication by lubricin is mediated by O-linked $\beta(1-3)\text{Gal-GalNAc}$ oligosaccharides. *Glycoconj. J.* **18**, 807-815
- 12 Flannery, C. R., Hughes, C. E., Schumacher, B. L., Tudor, D., Aydelotte, M. B., Kuettner, K. E. and Caterson, B. (1999) Articular cartilage superficial zone

- protein (SZP) is homologous to megakaryocyte stimulating factor precursor and is a multifunctional proteoglycan with potential growth-promoting, cytoprotective, and lubricating properties in cartilage metabolism. *Biochem. Biophys. Res. Commun.* **254**, 535-541
- 13 Ikegawa, S., Sano, M., Koshizuka, Y. and Nakamura, Y. (2000) Isolation, characterization and mapping of the mouse and human PRG4 (proteoglycan 4) genes. *Cytogenet. Cell Genet.* **90**, 291-297
- 14 Schumacher, B. L., Hughes, C. E., Kuettner, K. E., Caterson, B. and Aydelotte, M. B. (1999) Immunodetection and partial cDNA sequence of the proteoglycan, superficial zone protein, synthesized by cells lining synovial joints. *J. Orthop. Res.* **17**, 110-120
- 15 Zappone, B., Greene, G. W., Oroudjev, E., Jay, G. D. and Israelachvili, J. N. (2008) Molecular aspects of boundary lubrication by human lubricin: effect of disulfide bonds and enzymatic digestion. *Langmuir* **24**, 1495-1508
- 16 Schmidt, T. A., Plaas, A. H. and Sandy, J. D. (2009) Disulfide-bonded multimers of proteoglycan 4 PRG4 are present in normal synovial fluids. *Biochim. Biophys. Acta* **1790**, 375-384
- 17 Sheehan, J. K. and Thornton, D. J. (2000) Heterogeneity and size distribution of gel-forming mucins. *Methods Mol. Biol.* **125**, 87-96
- 18 Lohmander, L. S. (2004) Markers of altered metabolism in osteoarthritis. *J. Rheumatol. Suppl.* **70**, 28-35
- 19 Matyas, J. R., Atley, L., Ionescu, M., Eyre, D. R. and Poole, A. R. (2004) Analysis of cartilage biomarkers in the early phases of canine experimental osteoarthritis. *Arthritis Rheum.* **50**, 543-552
- 20 Pablos, J. L., Santiago, B., Tsay, D., Singer, M. S., Palao, G., Galindo, M. and Rosen, S. D. (2005) A HEV-restricted sulfotransferase is expressed in rheumatoid arthritis synovium and is induced by lymphotoxin-alpha/beta and TNF-alpha in cultured endothelial cells. *BMC Immunol.* **6**, 6
- 21 Whitelock, J. M. and Iozzo, R. V. (2002) Isolation and purification of proteoglycans. *Methods Cell Biol.* **69**, 53-67
- 22 Schulz, B. L., Packer, N. H. and Karlsson, N. G. (2002) Small-scale analysis of O-linked oligosaccharides from glycoproteins and mucins separated by gel electrophoresis. *Anal. Chem.* **74**, 6088-6097
- 23 Olson, F. J., Ludowyke, R. I. and Karlsson, N. G. (2009) Discovery and identification of serine and threonine phosphorylated proteins in activated mast cells: implications for regulation of protein synthesis in the rat basophilic leukemia mast cell line RBL-2H3. *J. Proteome Res.* **8**, 3068-3077
- 24 Eng, J. K., McCormack, A. L. and Yates, J. R. (1994) An approach to correlate tandem mass spectral data of peptides with amino acid sequences in a protein database. *J. Am. Soc. Mass Spectrom.* **5**, 976-989
- 25 Ceroni, A., Maass, K., Geyer, H., Geyer, R., Dell, A. and Haslam, S. M. (2008) GlycoWorkbench: a tool for the computer-assisted annotation of mass spectra of glycans. *J. Proteome Res.* **7**, 1650-1659
- 26 Yang, J., Rosen, S. D., Bendele, P. and Hemmerich, S. (2006) Induction of PNAd and N-acetylglucosamine 6-O-sulfotransferases 1 and 2 in mouse collagen-induced arthritis. *BMC Immunol.* **7**, 12
- 27 Bruehl, R. E., Bertozzi, C. R. and Rosen, S. D. (2000) Minimal sulfated carbohydrates for recognition by L-selectin and the MECA-79 antibody. *J. Biol. Chem.* **275**, 32642-32648

- 28 Poole, A. R. (1999) An introduction to the pathophysiology of osteoarthritis. *Front. Biosci.* **4**, D662-670
- 29 Brockhausen, I. (1999) Pathways of O-glycan biosynthesis in cancer cells. *Biochim. Biophys. Acta* **1473**, 67-95
- 30 Lloyd, K. O., Burchell, J., Kudryashov, V., Yin, B. W. and Taylor-Papadimitriou, J. (1996) Comparison of O-linked carbohydrate chains in MUC-1 mucin from normal breast epithelial cell lines and breast carcinoma cell lines. Demonstration of simpler and fewer glycan chains in tumor cells. *J. Biol. Chem.* **271**, 33325-33334
- 31 Przybysz, M., Maszczak, D., Borysewicz, K., Szechinski, J. and Katnik-Prastowska, I. (2007) Relative sialylation and fucosylation of synovial and plasma fibronectins in relation to the progression and activity of rheumatoid arthritis. *Glycoconj. J.* **24**, 543-550
- 32 Rudd, P. M., Elliott, T., Cresswell, P., Wilson, I. A. and Dwek, R. A. (2001) Glycosylation and the immune system. *Science* **291**, 2370-2376
- 33 Nimmerjahn, F., Anthony, R. M. and Ravetch, J. V. (2007) Agalactosylated IgG antibodies depend on cellular Fc receptors for in vivo activity. *Proc. Natl. Acad. Sci. U S A* **104**, 8433-8437
- 34 Chang, D. P., Abu-Lail, N. I., Guilak, F., Jay, G. D. and Zauscher, S. (2008) Conformational mechanics, adsorption, and normal force interactions of lubricin and hyaluronic acid on model surfaces. *Langmuir* **24**, 1183-1193
- 35 Jay, G. D., Torres, J. R., Warman, M. L., Laderer, M. C. and Breuer, K. S. (2007) The role of lubricin in the mechanical behavior of synovial fluid. *Proc. Natl. Acad. Sci. U S A* **104**, 6194-6199
- 36 Zappone, B., Ruths, M., Greene, G. W., Jay, G. D. and Israelachvili, J. N. (2007) Adsorption, lubrication, and wear of lubricin on model surfaces: polymer brush-like behavior of a glycoprotein. *Biophys. J.* **92**, 1693-1708
- 37 Uchimura, K. and Rosen, S. D. (2006) Sulfated L-selectin ligands as a therapeutic target in chronic inflammation. *Trends Immunol.* **27**, 559-565
- 38 Hiraoka, N., Kawashima, H., Petryniak, B., Nakayama, J., Mitoma, J., Marth, J. D., Lowe, J. B. and Fukuda, M. (2004) Core 2 branching beta1,6-N-acetylglucosaminyltransferase and high endothelial venule-restricted sulfotransferase collaboratively control lymphocyte homing. *J. Biol. Chem.* **279**, 3058-3067

Accepted Article

FIGURE LEGENDS

Figure 1 Analysis of acidic proteins from SF

(A) Elution profiles of the acidic fractions from DEAE anion exchange chromatography from four SF samples (two osteoarthritis OA1 and OA2 and two rheumatoid arthritis RA1 and RA2). (B) (C) and (D) shows acidic fraction analyzed by SDS-PAGE (3-8% Tris-Acetate gels) and stained with (B) Coomassie blue (B), Alcian blue (C) or probed with an antibody (378) against human lubricin (D).

Figure 2 Western and lectin blot analyses of the glycosylation of lubricin

SDS-PAGE (3- 8% Tris-Acetate gels) of the acidic SF protein fraction. (A) Western blot probed with anti-lubricin antibody 378 of the undigested (lane 1), digested with sialidase alone (lane 2) and digested with sialidase and *O*-glycanase (lane 3). (B) Lectin blot of the same arthritic SF sample undigested vs. digested, probed with PNA lectin specific for the *O*- linked disaccharides Gal β 1-3GalNAc α 1-

Figure 3 Analysis of *O*-linked oligosaccharides released from lubricin

(A) Partial base peak chromatograms showing the major NeuAc α 2-3Gal β 1-3GalNAc α 1 and NeuAc α 2-3Gal β 1-3(NeuAc α 2-6)GalNAc α 1 structures from the in-gel β -elimination of the Alcian Blue stained bands (Figure 1C) showing differential expression of the major ions between OA and RA patients. Additional detected oligosaccharides can be seen in Table 2. Proposed structures as featured in each inset were created with Glycoworkbench[25]. (B) Comparison of the MS intensities of NeuAc α 2-3Gal β 1-3GalNAc α 1 (white bars) and NeuAc α 2-3Gal β 1-3(NeuAc α 2-6)GalNAc α 1 (grey bars) from the two OA and the two RA samples, including standard deviation of the sample set.

Figure 4 Negative ion MS² spectra of sulfated core 2 oligosaccharides on lubricin

(A) MS² spectrum of the singly charged alditol [M – H]⁻ ion at *m/z* 829. (B) MS² spectrum of the singly charged alditol [M – H]⁻ ion at *m/z* 1120. Proposed structures as featured in each inset were created with Glycoworkbench[25]. For key to monosaccharide symbols see Figure 3

Figure 5 Inflammatory oligosaccharide epitopes on lubricin.

Western blot analysis of lubricin from arthritic synovial fluid (lane 1 in all blots, equivalent to 100 μ L fluid) and saliva as positive control for MECA-79 (lane 2 in all blots, equivalent to 10 μ L saliva). The DEAE eluate fraction of an arthritic SF sample was reduced and alkylated prior to run on 3-8% Tris acetate gels and blotted on to Immobilon P. (A) Western blot probed with 378, (B) MECA-79 and (C) anti-sialyl Lewis x antibody CSLEX1, showing correlation of 378 positive band with MECA-79 reactivity in the same arthritic SF sample. The same sample did not show reactivity with CSLEX1, indicating that lubricin did not contain the fucosylated sialyl Lewis x epitope.

Figure 6 Biosynthesis of *O*-linked oligosaccharides found on lubricin

Detected [M – H]⁻ ions of oligosaccharides in Table 2 and their proposed biosynthetic pathway. Cartoon of structures were created with Glycoworkbench[25]. Oligosaccharides detected on lubricin is labeled with their [M – H]⁻ ion. For key to

monosaccharide symbols see Figure 3.

THIS IS NOT THE VERSION OF RECORD - see doi:10.1042/BJ20100360

Accepted Manuscript

Table 1 Proteoglycan/mucin type proteins in synovial fluid by LC-MS²

Protein (Uniprot)	MW ^a (KDa)	Sample (# sequence matches/% peptide coverage /intensity of staining)			
		OA1	OA2	RA1	RA2
<u>Main component</u>					
Lubricin	350	6/7.2% **** ^b	8/8.0% ****	6/6.1% ****	10/10.4% ****
<i>Peptide sequences/AA position/exon</i>					
CFESFER/74-80/3		nd	x ^c	nd	x
DSQYWR/1213-1218/9		nd	nd	x	x
DAGYPKPIFK/1225-1234/9		nd	x	nd	nd
GGSIQQYIYK/1265-1274/10		x	x	x	x
ITEVWGIPSPIDTVFTR/1185-1201/8		x	nd	x	x
NWPESVYFFK/1254-1263/9		x	x	x	x
PALNYPVYGETTQVR/1286-1300/10		nd	x	nd	x
RPALNYPVYGETTQVR/1285-1300/10		nd	x	nd	x
SEDAGGAEGETPHMLLR/1094-1110/6		x	nd	nd	nd
SEDAGGAEGETPHMLLRPHVFMPEVTPDMDYLPR/1094-1127/6		nd	nd	nd	x
TFFFK/1208-1212/8		x	x	x	x
VPNQGIINPMLSDETNICNGKPV DGLTTLR/1128-1158/6-7		x	x	x	x
<u>Minor components</u>					
Versican	>350	nd ^d	4/1.8% **	4/2.0% *	nd
Aggrecan	188	nd	2/1.1%	nd *	nd
Cartilage oligomeric matrix protein	114	4/8.5% *	7/13.2% **	nd	11/24.7 **
	102	nd	17/29.0% **	14/28.2% *	10/19.7% *
	93	nd	15/29.5% **	nd	nd
Lumican	66	7/27.1% *	10/37.3% **	nd	nd
	55	4/14.1% *	10/37.3% **	10/34.8% **	10/34.6% **
	40	nd	6/22.6% *	4/13.1% *	7/23.2% *
Fibronectin	245	nd	31/16.5% **	9/5.1% **	17/10.3% **
IGHG1 protein	35-40	nd	nd	8/16.9% *	5/14.5% *

^aMolecular weight estimated from bands from SDS-PAGE (Figure 1)^bCoomassie Intensity criteria, ****= most intense, *= least intense^cnd = not detected/non-match according to peptide ID LC-MS²^dx means peptide identified by LC-MS²

Table 2 Relative ion intensity of O-linked oligosaccharides detected by graphitized carbon LC-MS in arthritic synovial fluid samples

[M - H] ⁻	Proposed Structure ^a	Sample			
		OA1	OA2	RA1	RA2
675		41%	51%	38%	35%
675		nd ^b	0.9%	nd	nd
749		nd	0.3%	nd	nd
829		nd	<0.3%	nd	nd
966		34%	32%	51%	57%
1040		nd	0.7%	nd	0.8%
1040		nd	1%	nd	0.4%
1120		nd	2%	nd	nd
1331		4%	3%	9%	4%

^afor key to monosaccharide symbols see Figure 3.

^bnd means not detected

Mass spectrometric data and structures are submitted to the UniCarbDB database (<http://glycobase.nibrt.ie/UniCarbDB>).

Accepted Manuscript

THIS IS NOT THE VERSION OF RECORD - see doi:10.1042/BJ20100360

Figure 1

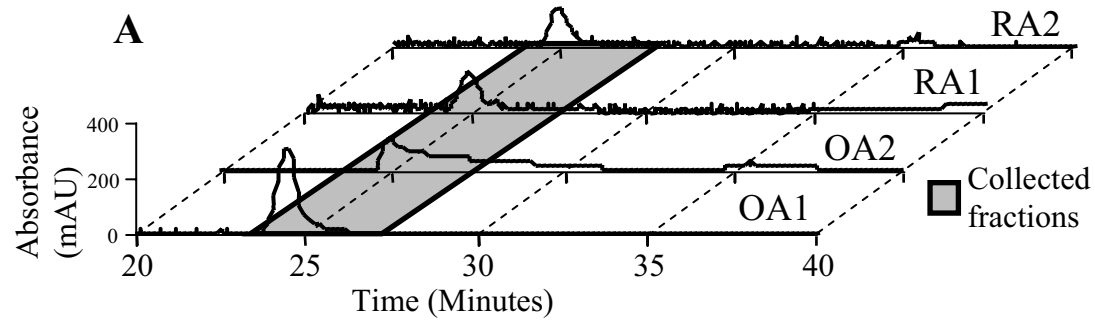

B

OA1 OA2 RA1 RA2



C

OA1 OA2 RA1 RA2



D

OA1 OA2 RA1 RA2

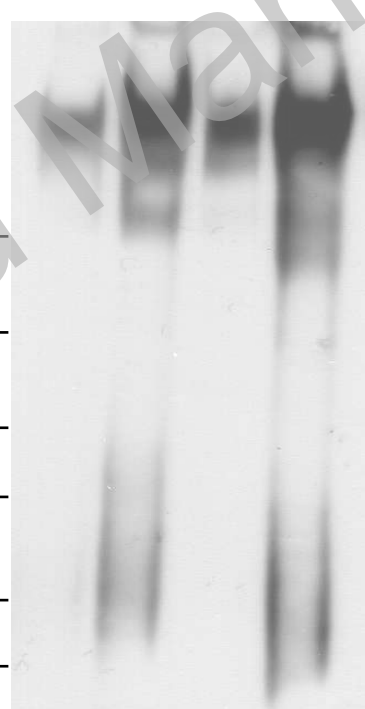
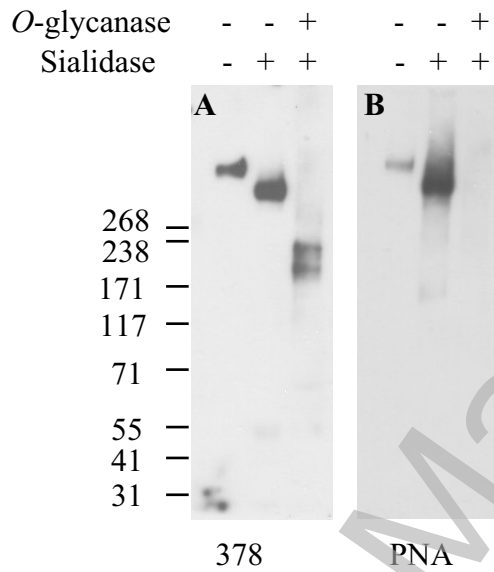

Figure 2



THIS IS NOT THE VERSION OF RECORD - see doi:10.1042/BJ20100360

Accepted Manuscript

Figure 3

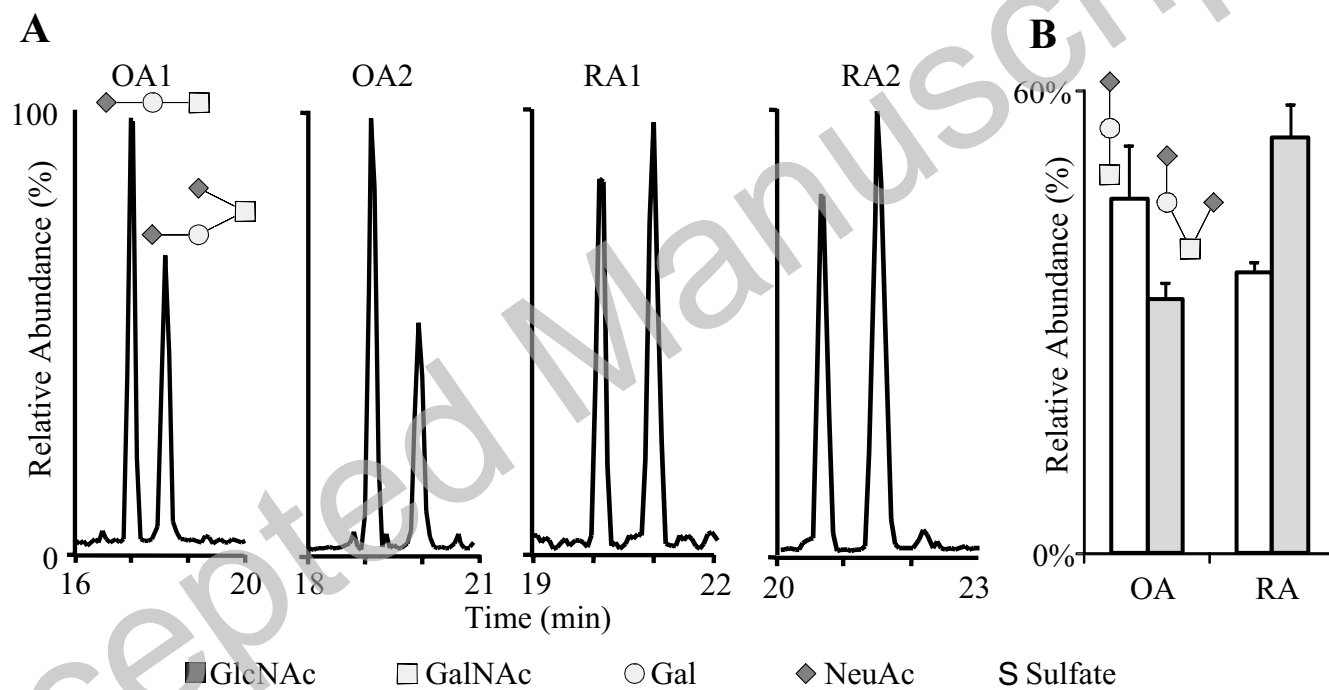
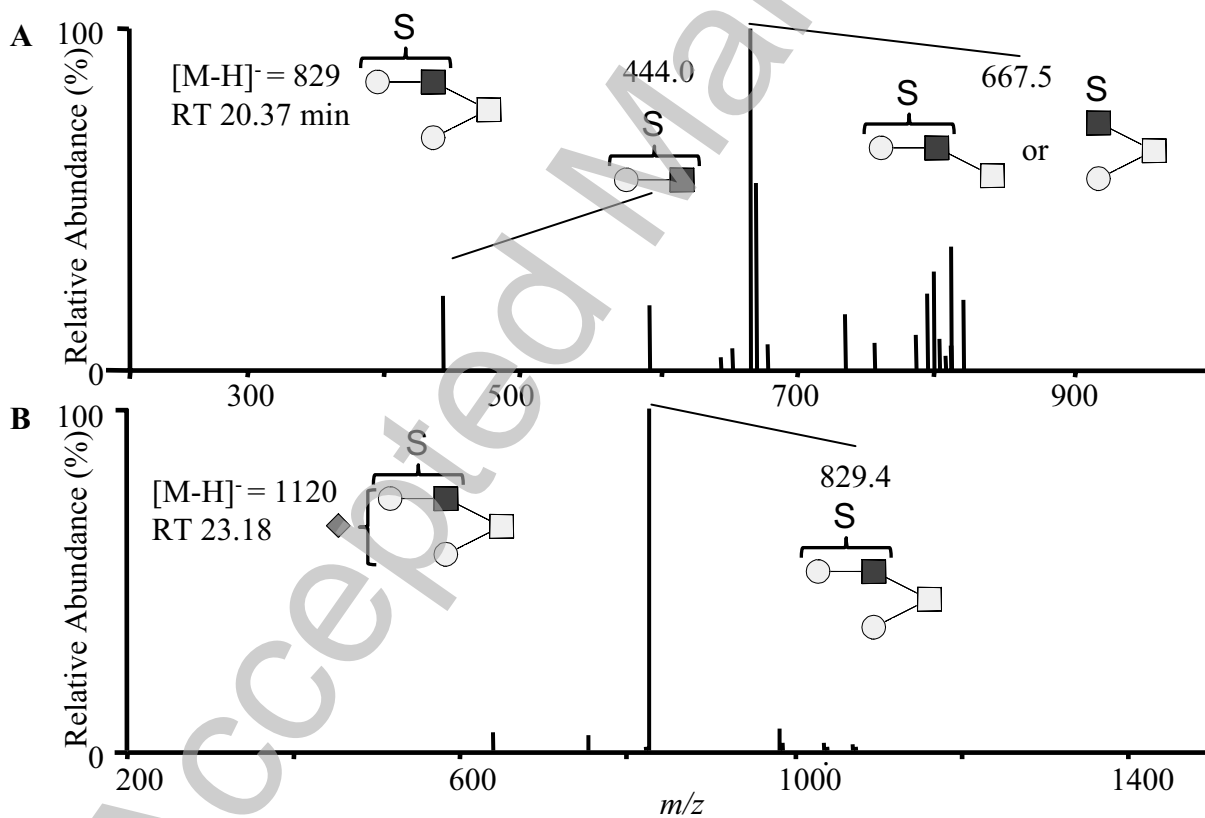

Figure 4



THIS IS NOT THE VERSION OF RECORD - see doi:10.1042/BJ20100360

Figure 5

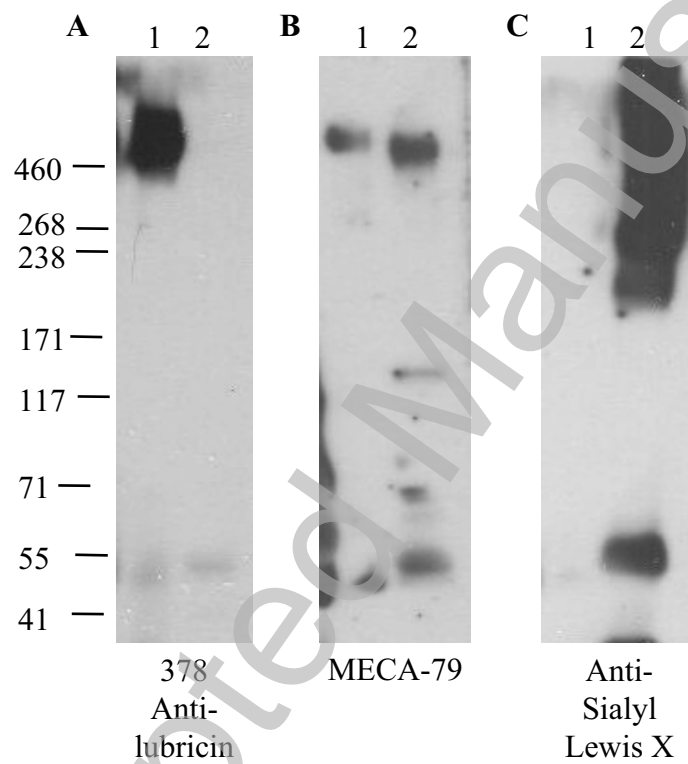
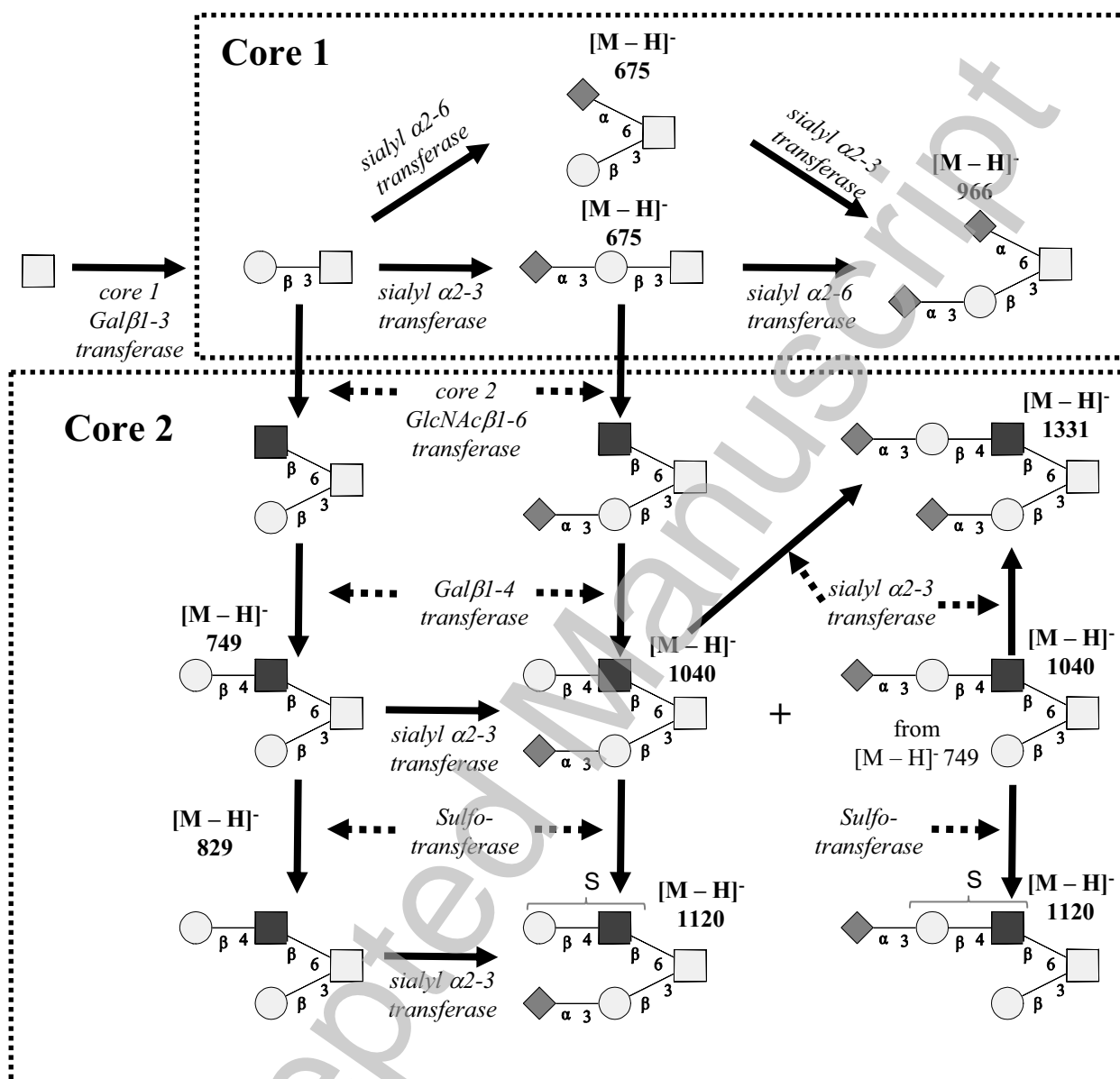

Figure 6



THIS IS NOT THE VERSION OF RECORD - see doi:10.1042/BJ20100360

Accepted