



**HAL**  
open science

## Formaldehyde hyperbaric fixation

André Clique, Jean-François Ponge, Dominique Especel, Daniel Sellos

► **To cite this version:**

André Clique, Jean-François Ponge, Dominique Especel, Daniel Sellos. Formaldehyde hyperbaric fixation. Collection Forum, 2007, 22 (1-2), pp.37-44. hal-00495358

**HAL Id: hal-00495358**

**<https://hal.science/hal-00495358>**

Submitted on 25 Jun 2010

**HAL** is a multi-disciplinary open access archive for the deposit and dissemination of scientific research documents, whether they are published or not. The documents may come from teaching and research institutions in France or abroad, or from public or private research centers.

L'archive ouverte pluridisciplinaire **HAL**, est destinée au dépôt et à la diffusion de documents scientifiques de niveau recherche, publiés ou non, émanant des établissements d'enseignement et de recherche français ou étrangers, des laboratoires publics ou privés.

**Author to whom correspondence should be addressed:**

André Clique

Mailing address: Muséum National d'Histoire Naturelle, UMR5178, Concarneau Marine  
Station, Place de la Croix, 29900 Concarneau, France

E-mail adress: [clique@mnhn.fr](mailto:clique@mnhn.fr)

Tel.: +33 2 98504285

## **Formaldehyde hyperbaric fixation**

A. Clique\*, J.F. Ponge\*\*, Yves Le Gal\*, D. Especel \*\*\*

\* Museum National d'Histoire Naturelle, UMR5178, Concarneau Marine Station, Place de la Croix, 29900 Concarneau, France

\*\* Muséum National d'Histoire Naturelle, CNRS UMR 7179, 4 avenue du Petit-Château, 91800 Brunoy, France

\*\*\* Museum National d'Histoire Naturelle, Health and Safety Department, 43 rue Buffon, 75005 Paris, France

### **Abstract**

The technique that we describe here relates to the fixation of fish in formaldehyde under hyperbaric conditions. Samples are placed in a chamber containing 5% formaldehyde. A film of oil is provided to create an interface between the liquid and the 2.5 bar air atmosphere. The minimum contact time at this pressure is 24 h. The tissues are then desaturated in stages. At the end of the cycle the samples are rinsed and placed under ethanol. The formaldehyde is neutralized. All of the operations are performed with the principal concern being to expose the researcher to as little formaldehyde vapor as possible.

## **Introduction**

Formaldehyde is a gas, sold in the form of a 40% aqueous solution, commonly referred to as formalin. It is generally used in a proportion of a few percent of stock solution in water. New regulations regarding carcinogenic, mutagenic and reprotoxic (CMR) products (INRS, 2006) require that if a product cannot be replaced by a substitute, the quantities handled should be reduced and the workers maximally protected from exposure. We worked within this framework on the fixation of small-to-medium size fish. The basic principle is one of saturating tissue under pressure in order to ensure that samples are fixed to their core. Desaturation is carried out with a “decompression-stages” protocol modeled on those stages observed for resurfacing divers. The formaldehyde is neutralized during the final phase.

### **Principle of fixing tissue in formaldehyde under hyperbaric conditions:**

The working principle is one of the directly saturating tissues with dissolved, pressurized formaldehyde gas. From a physiological point of view (Haldane model), various groups of tissues, the so-called “compartments” (Juvenspan and Thomas, 1997), are thought to exist. This classification is based on the fact that tissues are more or less readily in contact with gases (in the lungs, for example) or circulating blood. Tissues saturated with the latter include bone and fat. According to American (US Navy, 2005) and French (FFESSM, 2000) diving table data, saturation of all tissue groups is completed after seven periods totaling 720 min (12 h). It should be noted that the present study involves dead tissues, i.e., neither ventilated nor irrigated. Nevertheless, the values to be used are those of the two tissue groups mentioned above (bone and fat), even if the present paper relates more to muscle tissues.

After the period at 2 bar (roughly a 12-hour dive at -20 m), the tissues are thoroughly saturated with formaldehyde. The process of depressurization in stages begins next (as when resurfacing during a long-lasting conventional dive). Desaturation continues, in stages of several hours at various intermediate pressures, until all tissues are desaturated. The stage protocols are based on the above-mentioned French Navy tables, extended to diving at -60 m, and provide a factor-three safety margin (FFESSM, 2000). These stage parameters, starting at -20 m, were modified and adapted to our fixation requirements.

## **Experimental procedure**

### *Determination of pressure and time constants for the desaturation stages*

Initially, we sought to work directly in a phase of saturating, pressurized formaldehyde vapor. We were dissuaded, however, by the experiment's inherent danger, as well as the fact that formaldehyde breaks down in the presence of oxygen (Batista & Iwasita, 2006). Nevertheless, we made use of the initial experimental set-up to develop the stage protocol.

A diagram of the test bench is presented in Figure 1. For reasons of asepsis (samples are tested over several days at room temperature), the following protocol was chosen:

- 1) The samples are placed in the 'gas reservoir'.
  
- 2) A small amount of 5% formaldehyde is placed in the 'liquid reservoir'. A Divac 1.2 (100 mm Hg) vacuum pump/compressor depressurizes the 'liquid reservoir', thus turning the formaldehyde into vapor form and sending it to the 'gas reservoir' after a few minutes.

3) A device for bubbling air in a sulfite bath is then put in place in order to eliminate oxygen in the air for the compression sequence.

4) The same pump, now switched to compression, pressurizes the samples at 2.0 bar for approximately 24 h.

5) A micro-flow valve is then used to reduce the pressure in stages (residual vapors are trapped in a final outflow filter). The presence of a small amount of formaldehyde in vapor form is insufficient to fix the samples, but it ensures that the samples are partially sterilized, which helps to avoid decomposition at room temperature.

Various stage protocols were tested on various species. The following values were selected for the intermediate-stage pressures: 1.7 bar, 1.4 bar, 1.0 bar, 0.6 bar, 0.3 bar. The parameters for each stage are indicated in Table 1. For depressurization rates (Table 2), minimal values are expressed as the equivalent of a diver's surfacing rate in meters per minute (1 m/min is roughly 0.1 bar/min). The visual test selected to evaluate the proper execution of the desaturation procedure was the presence of bubbles in the vitreous humor of the eye, in accordance with hyperbaric ophthalmic medicine (<http://www.snof.org/maladies/diving.html> [in French]).

The fishes tested included breams, cods, mackerels and sardines. In fresh sardines (5 specimens), bubbles were not observed in the eye cavities using a binocular dissecting microscope (Fig. 2). On the other hand, two animals had damaged skin. It was not possible to know if this deterioration was due to the fact that the fish had spent a number of hours at room

temperature or if this phenomenon was a problem of desaturation, given that sardines are by their nature fragile to handle. For mackerel, cod and bream we did not observe damage to the surface of or the presence of bubbles in the vitreous humor.

*Fixation of samples (fish) under hyperbaric conditions*

The test bench modified in July 2007 is presented in Figure 3 and the start-up procedure is presented in Figure 4.

- 1) The 'transfer reservoir' is filled with 10 l of water; a film of oil (50 ml) is then deposited on the surface of the liquid. Formaldehyde QSP is added with a 50 ml syringe.
- 2) The samples are placed in the 'experimental chamber'.
- 3) The air circuit's release valve and the outlet gate are opened. The 'experimental chamber' fills by gravitational force. The outlet gate and the valve are closed.
- 4) Pressurization using a compressor (2 bar).
- 5) Fixation (24 or 48 h) at 2.0 bar.
- 6) Stages: the micro-flow valve is opened to control the transition between pressure levels. Flow is bubble by bubble. Once the required pressure is reached, the valve is closed until the following stage.

7) Draining after return to atmospheric pressure: the outlet gate is opened and approximately 0.15 bar is injected into the chamber. The liquid and the oil are forced back into the transfer reservoir. The three-way control valve isolates the system.

8) The experimental chamber is opened. The samples, under a film of oil, are rinsed and placed under ethanol.

9) If no new samples are to be treated the remaining formaldehyde can be neutralized by emptying it into a neutralization tank containing an aqueous solution of ammonium bicarbonate or carbonate (Kawamata and Kodera, 2004).

Several tests were carried out in July 2007 on batches of 4 or 5 frozen mackerels.

No specific difficulties were encountered. The animals appeared properly fixed compared to controls treated conventionally (one week in a 5% bath).

#### *Rinsing after fixation*

For rinsing the animals after fixation, and in order to save water and to shield the manipulator from residual formaldehyde vapor, we took advantage of an isolation spraying system which we developed and whose diagram is presented in Figure 5. This apparatus also makes it possible to treat small quantities of animals with formaldehyde at atmospheric pressure in a completely sealed manner.

#### *Packaging under alcohol*



For samples of reasonable size (30 cm maximum) we also developed a novel technique for limiting the researcher's exposure to alcohol vapor. Heat-sealed pouches were produced and the alcohol was stored at  $-30\text{ }^{\circ}\text{C}$ . The fixed sample is placed in the pouch,  $-30\text{ }^{\circ}\text{C}$  alcohol is added and the entirety heat-sealed. The procedure is low-risk since the vapor pressure of alcohol is very low at this temperature (Figs. 6 and 7). Another advantage of the method is a substantial decrease in alcohol requirement, 30% less compared to conventional packaging. For larger animals, storage in drums remains useful.

## **Discussion**

This novel method meets our three initial objectives:

- 1) To improve researcher' security by eliminating exposure to formaldehyde vapor, in accordance with new European Community's CMR regulations (INRS, 2006)
- 2) To decrease the time lapse samples are in contact with formaldehyde
- 3) To produce a device that can be used as well in the laboratory as in the field

The problem of vapor exposure is solved: the system is completely sealed in its hyperbaric phase. Workers are exposed a little during the rinsing process: the thin film of oil covering the samples upon exit from the chamber greatly reduces exposure by formaldehyde vapor. The film of oil is eliminated during the rinsing phase, which is carried out in a closed chamber and is autonomous. The formaldehyde is then neutralized by ammonium bicarbonate. The process (gravity) is such that the oil comes to the surface after neutralization. Any vapors are thus

very few. In our view, ammonium bicarbonate is the most appropriate solution for neutralization: ammonia, which neutralizes formaldehyde by forming hexamine (Frosin et al., 1980), was also tested (hospital technique), as well as sodium hypochloride (bleach). The latter two products require the use of masks whereas ammonium bicarbonate, a skin irritant, requires only gloves. Moreover, bleach can, under certain conditions, react with formaldehyde with explosive results (Walker, 1975) and form bis(chloromethyl)ether, a powerful carcinogen (<http://www.ch-aix.fr/pro/theme/anapath/prevrisques.htm>). We did not test the destruction of aldehydes by potassium permanganate (Picot and Grenouillet, 1992).

Reducing the time necessary for the fixation of tissues was also an original objective. Saturation of tissues under hyperbaric conditions meets this aim. Maceration time under formaldehyde is clearly less compared to the conventional immersion method: for example, large samples typically requiring roughly one month of contact in a formaldehyde bath, not including rinsing time, can be treated in 48-72 h.

Rinsing in an isolated system uses water economically: the typical rinsing process consumes roughly 7,200 liters of water (5 l/min) compared to 5 x 10 liters for our method. Note that in the chamber, the volume of compressed air is small compared to that of the water/formaldehyde mixture (this is also a pressurized-explosion safety criterion). However, the presence of micro-leaks over long periods can jeopardize the experiment. As a safety measure, we coat our seals/joints with Loctite 5923<sup>®</sup>, a so-called “tacky film”.

Determining decompression stages proved to be empirical in the absence of data on dead tissues. It should be noted, however, that the observation of bubbles in animal eyes

(<http://www.snof.org/maladies/diving.html>) remains a rather reliable criterion for the success or failure of the decompression procedure.

All of our experiments were performed in the laboratory. This does not mean that development of a field method has been neglected. Most laboratories have basic equipment such as electric compressors, for example. Manual pressurization or a supply of pressurized gas from a scuba-diving tank, for example, could be considered for use in a field setting. All our decompression stages were carried out manually thus they are immediately applicable in the field. Nothing, however, prevents the use of an automated stage controller system fed by pressure sensors (either in the laboratory using its electrical supply or in the field using a battery source). There are two principal advantages of a computer-controlled system: on one hand, it would be possible to automatically compensate for possible micro-leaks, on the other, the researcher would no longer be restricted to a schedule governed by the requirements of the decompression schedule.

The entirety of our process has been filed with France's *Institut National de la Propriété Intellectuelle* (INPI Soleau fund).

### **References:**

Batista, E.A., and T. Iwasita. 2006. Adsorbed intermediates of formaldehyde oxidation and their role in the reaction mechanism. *Langmuir* 22:7912-7916.

FFEFFSM. 2000. Tables de la Marine Nationale 1990 MN90, version 12/1/2000.

<http://plongee.asparis7.com/pdf/mn90.pdf>

Frosin, V.N., V.B. Tsibikov, G.I. Izvekova, B.Y. Rabin'kii, S.V. Pakhomov, N.V. Ramkova, M.I. Alekseeva, N.V. Kareev, T.V. Likhtman, P.I. Ryabov, and N.I. Komarkova. 1980. Selection of a mode for formaldehyde-gas sterilization. *Biomedical Engineering* 14:178-181.

INRS, 2006. Produits chimiques cancérrogènes, mutagènes, toxiques pour la reproduction. Classification réglementaire, Aide-mémoire Technique ED 976.

Juvensenspan H., and C. Thomas. 1997. Plonger aux mélanges. Eugen Ulmer, Paris, 186 pages.

Kawamata, S., and H. Koderu. 2004. Reduction of formaldehyde concentrations in the air and cadaveric tissues by ammonium carbonate. *Anatomical Science International* 79:152-157.

Picot, P. and P. Grenouillet. 1992. La sécurité en laboratoire de chimie et de biochimie. Lavoisier, Paris.

U.S. Navy. 2005. Diving Manual, Revision 5.

<http://www.supsalv.org/manuals/diveman5/divManual5.htm>

Walker, J.F. 1975. Formaldehyde, 3rd ed. Krieger, Huntington, New York.

## **Acknowledgements**

Special thanks are due to Ms. Elena Luchetti and Mr. S. Iglésias of the Marine Biology Station in Concarneau for their technical assistance, as well as to the French National Museum of Natural History's Health and Safety Department for its support and encouragement.

**Table 1.** Parameters for each depressurization stage

<b>Pressure (in bars)</b>	<b>Time under pressure</b>
Initial = 2.0	24 h
Stage 1 = 1.7	1 h
Stage 2 = 1.4	2 h
Stage 3 = 1.0	3 h
Stage 4 = 0.6	4 h
Stage 5 = 0.3	12 h

**Table 2.** Depressurization rates during each stage of the process

<b>Depressurization stages (in bars)</b>	<b>Rate during each stage (in m/min)</b>
2.0 → 1.7	0.6
1.7 → 1.4	0.3
1.4 → 1.0	0.3
1.0 → 0.7	0.3
0.7 → 0.3	0.15
0.3 → atm	0.06

**Figure captions**

**Fig. 1** Component parts of the initial test bench

**Fig. 2** Absence of bubbles in the vitreous humor of sardines in comparison with a hyperbaric accident in the rat (bubbles in the eye of a rat subjected to high pressure followed by sudden decompression; the bubbles are visible evidence of a decompression accident). Radiograph provided by Dr. Lanphier at <http://www.snof.org>

**Fig. 3** Test bench modified for a liquid phase process

**Fig. 4** Summary of the fixation process

**Fig. 5** Formaldehyde-treatment and rinsing apparatus (pressure of circulating liquid = 3 bars): in fixation mode, release via the spray-heads ensures the formaldehyde is vaporized throughout the chamber

**Fig. 6** Packaging under alcohol at low temperature

**Fig. 7** Samples of mackerel packaged in plastic pouches



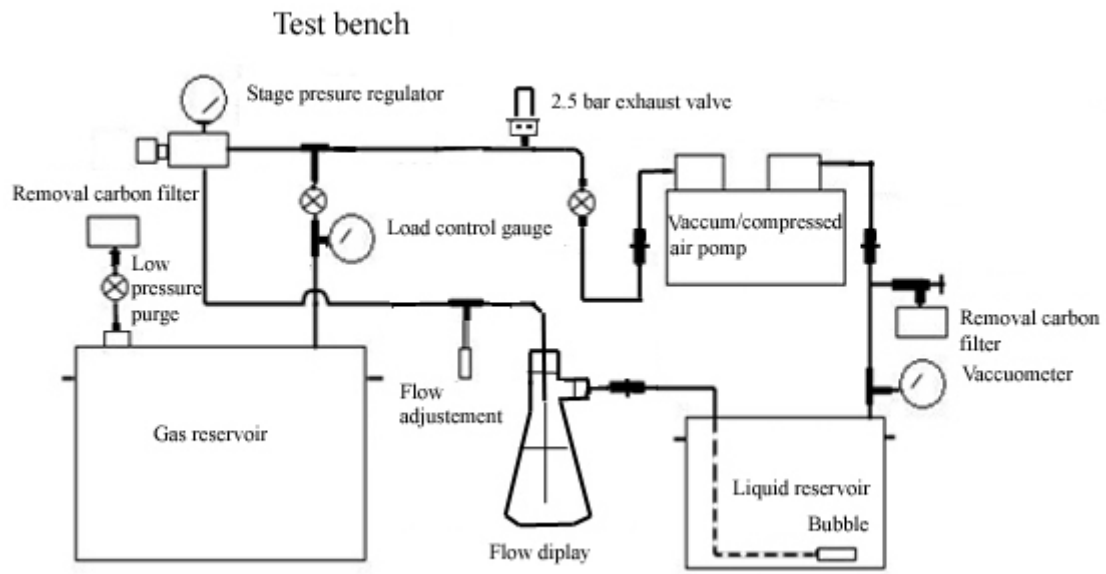

Fig. 1

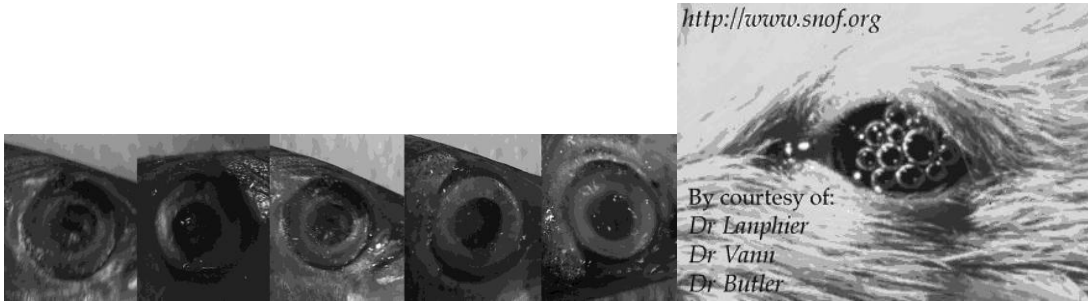

Fig. 2

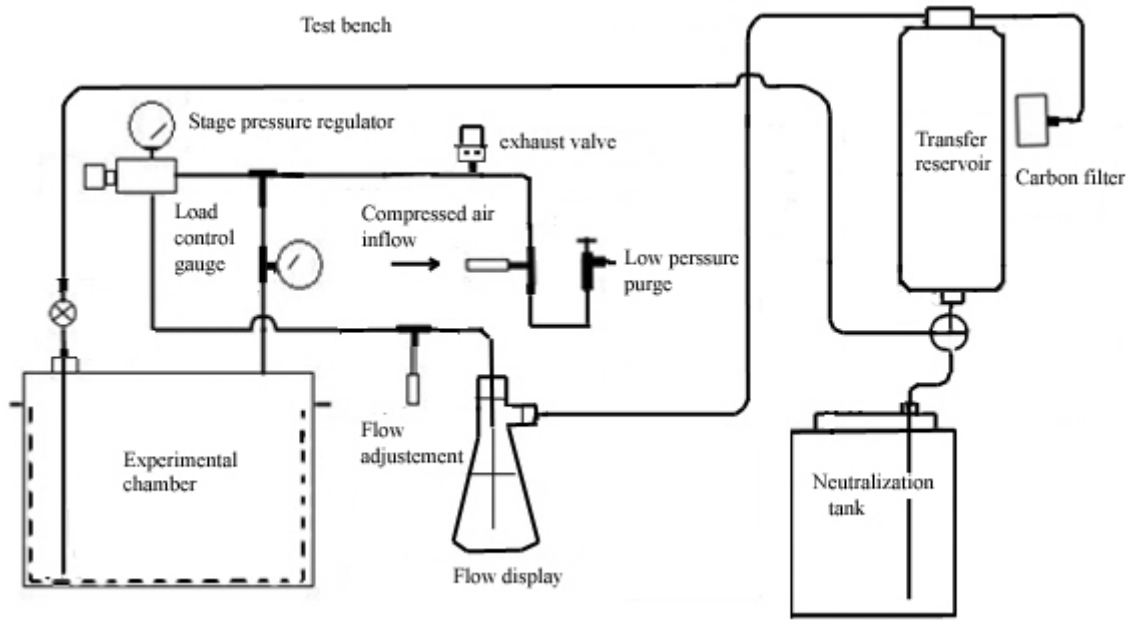

Fig. 3

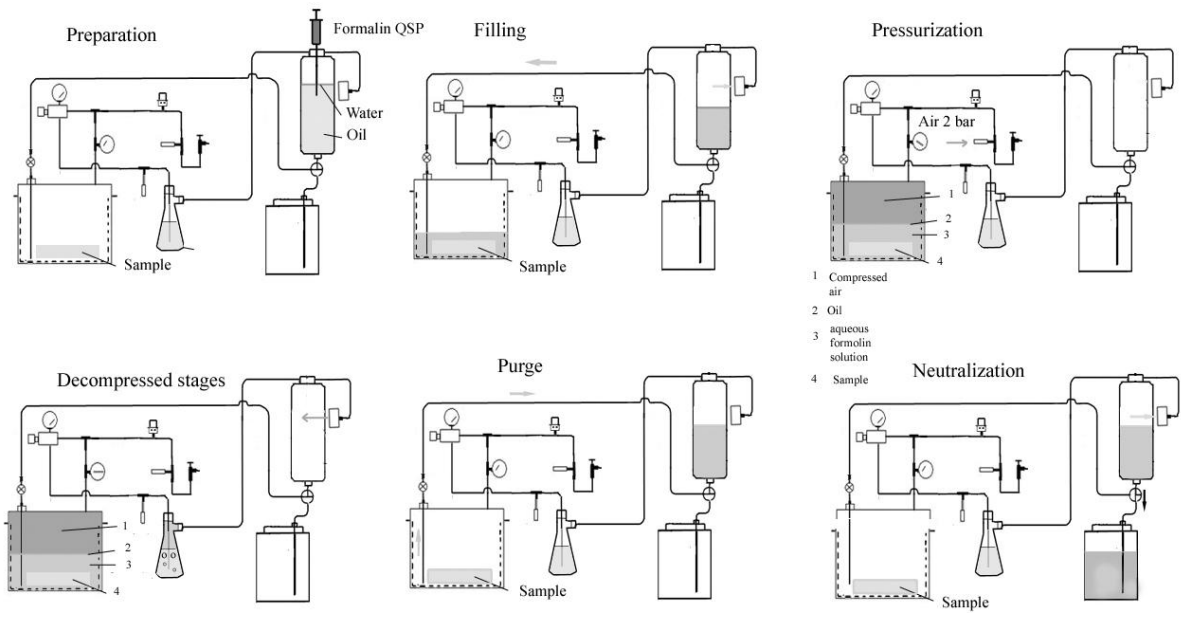
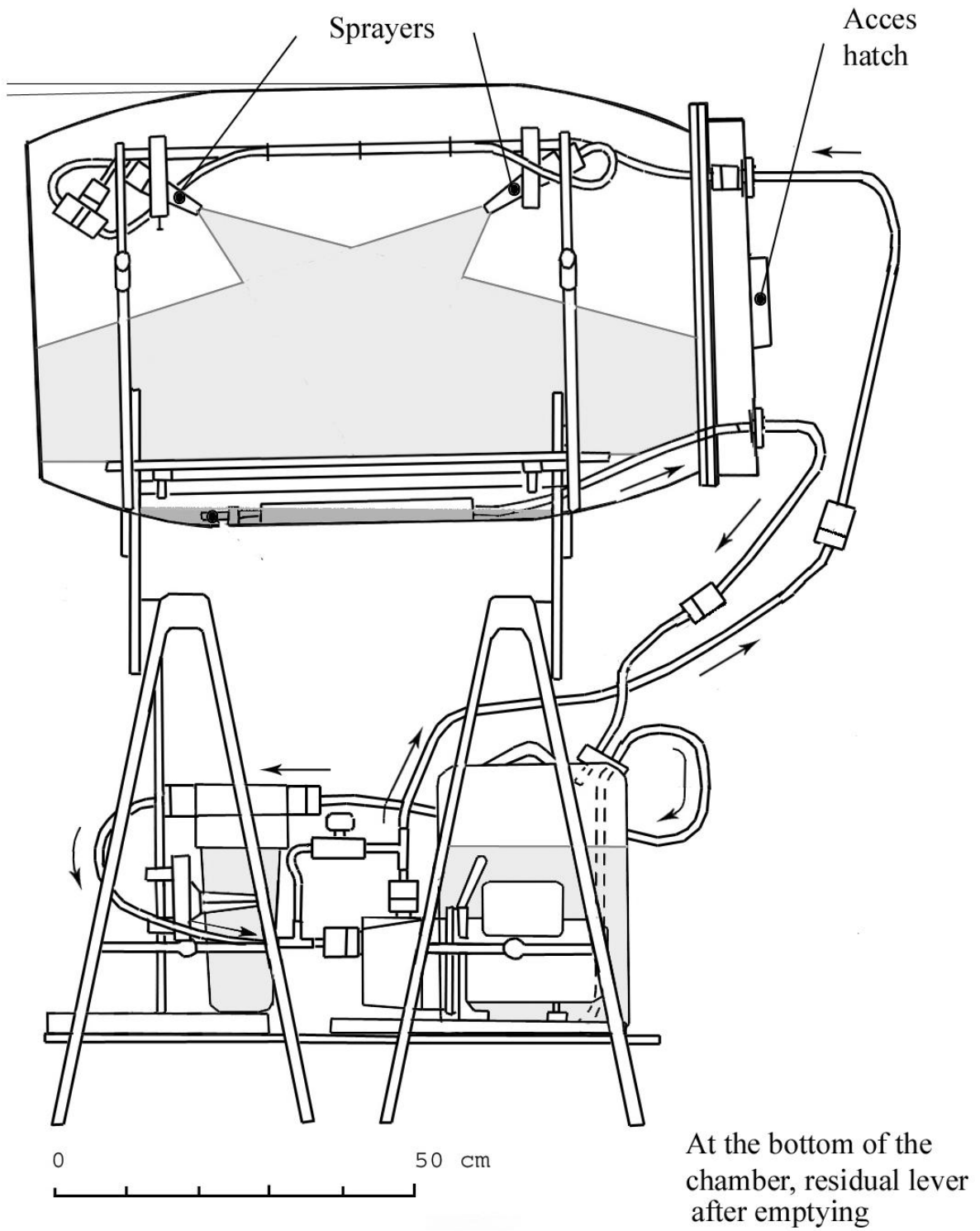

Fig. 4



Fluid circulation diagram

Fig. 5

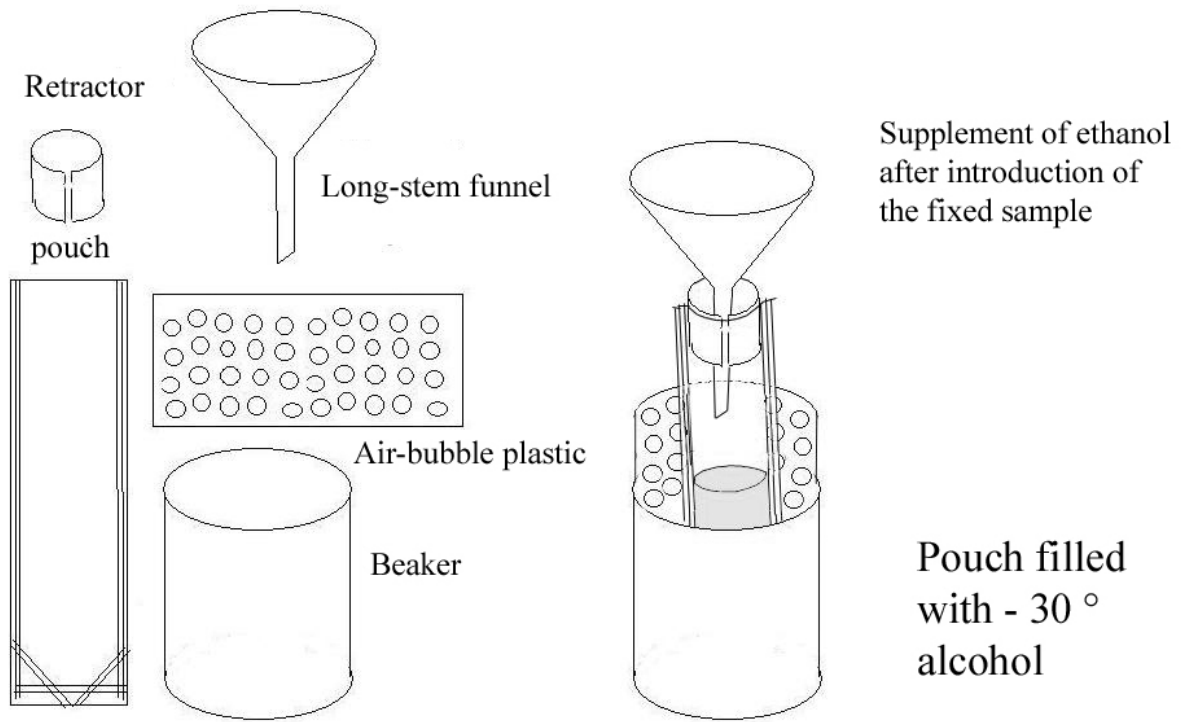

Fig. 6



Fig. 7