



HAL
open science

Characterisation of semiconductor optical amplifiers for all-optical regeneration

Minh Nguyet Ngo, Mathilde Gay, Laurent Bramerie, Gwenaëlle Girault, Quang Trung Le, Jean-Claude Simon, Romain Brenot, Guang-Hua Duan, Douglas A. Reid, Liam P. Barry

► **To cite this version:**

Minh Nguyet Ngo, Mathilde Gay, Laurent Bramerie, Gwenaëlle Girault, Quang Trung Le, et al.. Characterisation of semiconductor optical amplifiers for all-optical regeneration. International Workshop on Photonics and Applications 2008 (IWPA 2008), Sep 2008, Nha Trang, Vietnam. pp.B-35. hal-00490845

HAL Id: hal-00490845

<https://hal.science/hal-00490845>

Submitted on 9 Jun 2010

HAL is a multi-disciplinary open access archive for the deposit and dissemination of scientific research documents, whether they are published or not. The documents may come from teaching and research institutions in France or abroad, or from public or private research centers.

L'archive ouverte pluridisciplinaire **HAL**, est destinée au dépôt et à la diffusion de documents scientifiques de niveau recherche, publiés ou non, émanant des établissements d'enseignement et de recherche français ou étrangers, des laboratoires publics ou privés.

CHARACTERISATION OF SEMICONDUCTOR OPTICAL AMPLIFIERS FOR ALL-OPTICAL REGENERATION

M. N. Ngo ^a, M. Gay ^a, L. Bramerie ^a, G. Girault ^a, Q. T. Le ^a, J.-C. Simon ^a, R. Brenot ^b, G.-H. Duan ^b, D. Reid ^c, L. Barry ^c

^a) FOTON-CNRS, ENSSAT / Université de Rennes 1, 6 rue de Kerampont, 22305 Lannion, France, ngo@enssat.fr

^b) Alcatel Thales III-V Lab, Route Départementale 128, 91767 Palaiseau, France, guanghua.duan@3-5lab.fr

^c) RINCE, Dublin City University, Glasnevin, Dublin 9. Ireland, liam.barry@dcu.ie

Abstract: We report on the characterisations of different semiconductor optical amplifiers (SOA) which are designed and fabricated for All-Optical Regeneration. Dynamic measurements in pump-probe configuration show short time response of around 50 ps. Chirp measurements by FROG technique are also reported. The characterisations demonstrate the potential of these components to be associated with interferometer and optical filtering in order to achieve regeneration functions at bit rates of 40 Gbit/s and above.

Key words: *Semiconductor optical amplifiers, all-optical regeneration*

1. Introduction

Until now, signal processing in long distance transmission systems is performed by optoelectronic repeaters. However the higher the bit rate, the more expensive and complex the optoelectronic repeaters. In this circumstance, all-optical devices become attractive solutions. Therefore, an all-optical solution should have criteria such as stability, compactness, simplicity of operation and low-power consumption. The two functionalities which are closest to implementation in real systems are wavelength conversion and regeneration.

Regenerators are principally fibre-based [1-3] or semiconductor-based devices [4-6]. These last ones offer many advantages: small size, simple electrical pumping, broad spectral range and opportunities for integration and mass production. Among these components, the semiconductor optical amplifier (SOA) with gain saturation, low optical and electrical power consumption and fast response is a good candidate. Moreover, novel generation of SOAs [7], quantum-dot SOA, and new SOA based technique [8] show performances at high bit rates, 40 Gbit/s for regeneration and up to 320 Gbit/s for wavelength conversion. Especially quantum dots SOAs are predicted to have a very fast response [9] and could induce lower additional chirp in the modulated signal than bulk ones, thereby allowing a longer transmission distance [10]. These results give strong motivations to exploit SOAs for all-optical regeneration. In this paper, we present characterisations of different SOA which are designed and fabricated for all-optical regeneration applications. All these SOAs emit in the C-band. Their gain recovery time responses are measured via pump-probe experiments. This parameter is primary to evaluating patterning effects and the bit rate at which these SOAs could be operated. At last, the study of chirp induction to evaluate linewidth enhancement factor (Henry factor) is also presented. The Henry factor is important in case of association with interferometers or shifted filtering techniques.

2. Characterized devices

Various SOAs from Alcatel-Thales III-V lab were characterized in the framework of the French project FUTUR. These SOAs, presented in table 1, are designed and fabricated in order to perform different functions of regeneration at 40 Gbit/s and 160 Gbit/s. As far as bulk

structure based SOAs, two chips were studied with the same length but with different confinement factor (20% and 80%). This last parameter affects significantly the time response which is important when the bit rate increases. These bulk structures were compared to a quantum dot SOA.

Table 1. Description of measured SOAs.

SOA	Active structure	Optical confinement (%)	Chip length (mm)
1	Bulk	20	1
2	Bulk	80	1
3	Q. Dot	~1	2

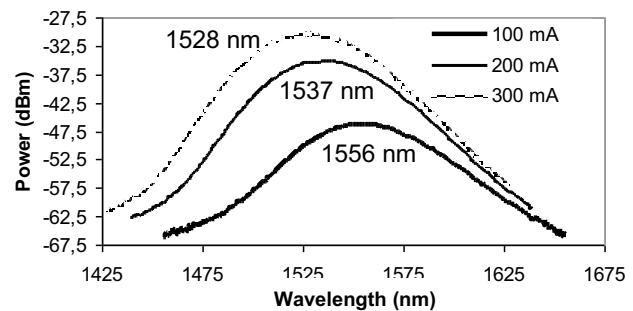

Figure 1. Amplified spontaneous emission of QD-SOA for different bias currents.

The two bulk SOAs had a gain peak around 1550 nm and an internal gain around 30 dB. For the QD-SOA, its spectral emission is displayed in figure 1 for different bias current. The emission peak is located in the C-band at bias current lower than 300 mA and covers almost the entire C-band for currents lower than 300 mA. In the literature, one of the first quantum dot structures emitting in the C-band was published in 2003 [11] and a little later some quantum dots structure have been exploited for all-optical regeneration [7, 12]. The internal gain of QD structure is 20 dB.

3. Gain dynamic measurement

SOA-based wavelength conversion and regeneration schemes exploit gain modulation, cross-phase modulation or four-wave mixing. When the gain modulation is used, attention must be paid to the gain recovery time of the SOA. More exactly, we consider this time response as the time that gain needs to recover from 10% to 90% of its steady-state value. We measure this time via a pump-probe configuration. The experimental measurement set-up is shown in the figure 2.

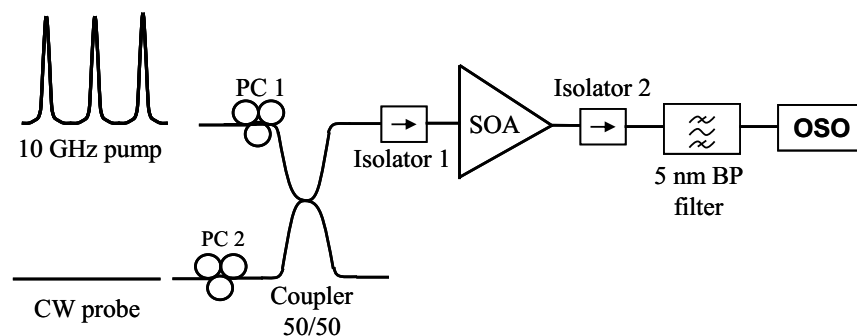

Figure 2. Scheme of gain dynamic measurement

A 10 GHz optical clock is injected into the SOA to modulate its gain. For each measured SOA, the pump wavelength is selected as the peak of the amplified spontaneous emission spectrum. The probe is provided by a CW tunable laser. A 5 nm optical Band Pass (BP) filter is used to reject the pump and select the probe to Optical Sampling Oscilloscope (OSO) with a time resolution of 1 ps. The gain recovery time is measured for different SOA and for different gain compressions. Results are shown in figure 3.

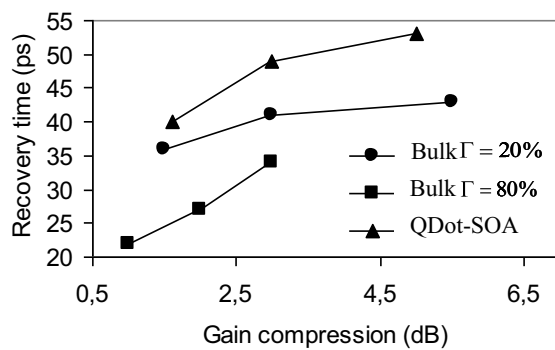

Figure 3. Gain recovery time as a function of gain compression.

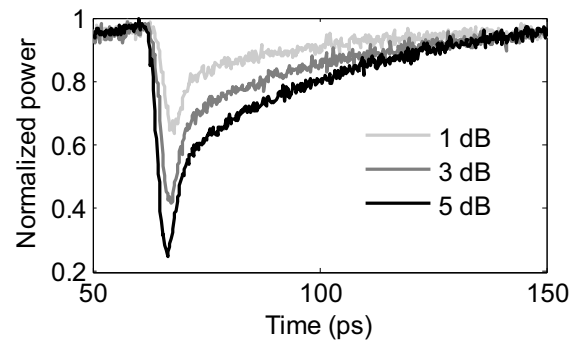

Figure 4. Waveforms of CW probe light at the QD-SOA output for various gain compressions, modulated by a 2.3 ps pulse pump.

In each case, the gain recovery times of the three SOAs increase with their gain compressions. This result could be explained by the fact that the greater the gain compression, the greater depletion of electrons in excited states by stimulated emission. The SOA#1 (See table 1) has a gain recovery time around 40 ps for 3 dB of gain compression and the second one has a smaller time around 27 ps for the same gain compression. The two SOA have the same length of waveguide. The gain recovery time of the 2nd structure is shorter because the gain recovery time is inversely proportional to the confinement factor [13]. At 40 Gbit/s, the bit slot is 25 ps long, therefore the slow time response of the SOA#1 may introduce patterning effects which could lead to signal degradations. On the contrary, the SOA#2 could be exploited at this bit rate with small gain compression (<3dB).

Sample 3 (QD-SOA) presents a gain recovery time of around 50 ps for 3 dB of gain compression. In the figure 4, we present the waveforms of the modulated probe at the QD-SOA output and for different gain compressions and a pump pulse width of 2.3 ps. Similar waveforms were also achieved with the SOA#1 and the SOA#2. These curves show the presence of ultrafast gain dynamic, which is dominated by intraband processes, and the presence of slower gain dynamic, which is linked to interband recombinations [14]. The two time constants were evaluated by combining two simple exponential functions, giving a time-constant of 2 ps for fast processes and a time-constant of 65 ps for slow processes. The measured time-constant of fast processes is limited by the input pump pulsewidth ; this time should be measured more exactly with shorter pulses and a higher time resolution device. Because of the slow processes, this SOA is not fast enough to operate at bit rate above 40 Gbit/s. However this time response was achieved with a SOA whose confinement factor was only 1%. If this parameter could be increased, we could significantly reduce the gain recovery time of the QD-SOA. Then we could expect a time response smaller than 10 ps with a confinement factor greater than 10% as it is shown thanks to simulations in the reference [9].

4. Induced chirp measurement

In some cases, it is useful to have SOAs which induce low chirp to avoid limited transmission distances. On the contrary, in the case of shifted filtering [8], or in interferometer configuration [15], the chirp induced plays an important role and it could be useful to evaluate Henry factor. By using the FROG (Frequency Resolved Optical Gating) technique, we have measured the induced chirp of a 10 GHz optical clock signal injected directly in the investigated SOA. The pulse-width is about 2 ps and initial pulses have a linear chirp. At the output of the SOA, the signal is analysed in phase and amplitude with a FROG to deduce

additional chirp. We investigated and compared the induced chirp by the two bulk SOAs, SOA#1 and SOA#2. Results are shown in the figure 5.

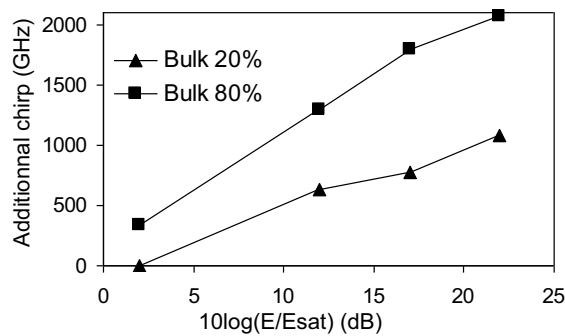

Figure 5. Induced chirp by SOA as a function of E/Esat.

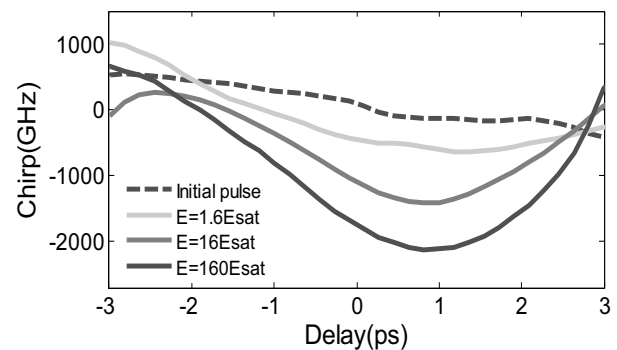

Figure 6. Chirp-form changes by SOA 80% confinement factor of a pulse for various E/Esat.

Because of the pump pulsewidth (2.3 ps) is much smaller than the gain recovery time of the two SOAs (superior to 20 ps), the SOAs are in saturation regime by energy. Then the additional chirp is measured for different values of ratio between the pulse and the SOAs saturation energies E/Esat. An additional chirp of 2000 GHz, which is measured at its maximum, is obtained with SOA#2 when the pulse energy was E=160Esat (or 10log(E/Esat)=22). With both bulk SOAs, the induced chirp increases rapidly when E/Esat increases. This result can be explained by the fact that the induced chirp is proportional to the rate of change of the gain compression and this increases with E/Esat. As expected, SOA#2 which possessed a high confinement factor (80%) induced twice as much chirp as SOA#1 with its lower confinement factor (20%). The higher frequency deviation is due to faster carrier dynamics of SOA#2. In figure 6, the chirp is plotted as a function of time indicating the chirp profiles of pulses before and after SOA#2. The initial pulse presents a linear chirp. At the output, the chirp is non-linear, typically with a pseudo-parabolic profile. This non-linear shape of the chirp could be difficult to compensate for, but the great induced chirp should be useful and exploitable in configurations in which phase modulation is used.

5. Conclusion

We characterized various SOAs in bulk and quantum-dot structures. The bulk SOA with the higher confinement factor has shown some potential to operate regeneration at 40 Gbit/s in weak gain compression (<3dB) regimes thanks to its fast gain dynamic (gain recovery time <25 ps). The QD-SOA has shown the presence of ultra-fast processes and slow processes and an effective 10%-90% gain recovery time of around 50 ps for 3 dB gain compression in spite of its small confinement factor (~1%). We also quantified the high level of chirp induced (2000 GHz) by bulk SOA, which could be exploited in configurations in which phase modulation is used.

Acknowledgments

This work has been carried out in the framework of the French research program FUTUR and the European project ERA-SPOT1 (ORION 160). These programs are supported by "Région Bretagne", by FEDER and by "Ministère de la recherche". Results were achieved in the PERSYST platform and RINCE laboratory.

References

1. P. Mamyshev, *Proc. ECOC1998*, pp. 475-476, 1998.
2. M. Asobe, T. Kanamori, K. I. Kubodera, *J. Quantum Electron.*, vol. 29, no. 8, pp. 2325-2333, 1993.

3. N. J. Dohan, D. Wood, *Opt. Lett.*, vol. 13, no. 1, pp. 56-58, 1998.
4. R. J. Manning, D. A. O. Devies, A. D. Ellis, D. M. Patrick, Proc. *Topical Meeting Opt. Amplifiers and their Applicat. (OAA '95)*, SaC1, Davos (Suisse), pp. 226-229, 1995.
5. K. Nishimura, R. Inohara, M. Tsurukawa, M. Usami, *Optical Fiber Communication Conference 2003*, paper TuP5, 2003.
6. O. Leclerc, G. Aubin, P. Brindal, J. Mangedey, H. Choumane, S. Barre, J. L. Oudar, *Electron. Lett.*, vol. 36, no. 23, pp. 1944, 2000.
7. T. Akiyama, M. Ekawa, M. Sugawara, K. Kawaguchi, H. Sudo, H. Kuwatsuka, H. Ebe, A. Kuramata, and Y. Arakawa, *Optical Fiber Communication Conference 2005*, paper OWM2, 2005.
8. Y. Liu, E. Tangdionga, Z. Li, H. de Waardt, A. M. J. Koonen, G. D. Khoe and H. J. S. Dorren, *Optical Fiber Communication Conference 2006*, paper PDP28, 2006.
9. M. Sugawara, T. Akiyama, N. Hatori, Y. Nakata, H. Ebe and H. Ishikawa, *Measurement Science and Technology*, vol. 13, pp. 1683-1691, 2002.
10. R. Brenot, M. D. Manzanedo, J.-G. Provost, O. Legouezigou, F. Pommereau, F. Poingt, L. Legouezigou, E. Derouin, O. Drisse, B. Rousseau, F. Martin, F. Lelarge, and G. H. Duan, *Proc. ECOC2007*, paper 08.6.6_1569044496, 2007.
11. C. Paranthoen, C. Platz, G. Moreau, N. Bertru, O. Dehaese, A. Le Corre, P. Miska, J. Even, H. Folliot, C. Labbe, et al., *J. Crystal Growth*, vol. 251, no. 1, pp. 230-235, 2003.
12. J. Renaudier, B. Lavigne, M. Jourdran, P. Gallion, F. Lelarge, B. Dagens, A. Accard, O. Legouezigou, and G. H. Duan, *Proc. ECOC 2005*, Th 4.3.4, 2005.
13. L. Zhang, I. Kang, A. Bhardwaj, N. Sauer, S. Cabot, J. Jaques, and D. T. Neilson, *Photon. Technol. Lett.*, vol. 18, no. 22, pp. 2323-2325, 2006.
14. M. van der Poel, E. Gehrig, O. Hess, D. Birkedal, and J. Hvam, "Ultrafast gain dynamics in quantum-dot amplifiers: Theoretical analysis and experimental investigations", *J. Quantum Electron.*, vol. 41, no. 9, pp. 1115-1123, 2005.
15. J. Leuthold, C.H. Joyner, B. Mikkelsen, G. Raybon, J.L. Pleumeekers, B.I. Miller, K. Dreyer and C.A. Burrus, *Electron. Lett.*, vol. 36, no. 13, pp. 1129-1130, 2000.