



HAL
open science

Analytic Regularity for Linear Elliptic Systems in Polygons and Polyhedra

Martin Costabel, Monique Dauge, Serge Nicaise

► **To cite this version:**

Martin Costabel, Monique Dauge, Serge Nicaise. Analytic Regularity for Linear Elliptic Systems in Polygons and Polyhedra. 2010. hal-00454133v1

HAL Id: hal-00454133

<https://hal.science/hal-00454133v1>

Preprint submitted on 8 Feb 2010 (v1), last revised 28 Oct 2011 (v3)

HAL is a multi-disciplinary open access archive for the deposit and dissemination of scientific research documents, whether they are published or not. The documents may come from teaching and research institutions in France or abroad, or from public or private research centers.

L'archive ouverte pluridisciplinaire **HAL**, est destinée au dépôt et à la diffusion de documents scientifiques de niveau recherche, publiés ou non, émanant des établissements d'enseignement et de recherche français ou étrangers, des laboratoires publics ou privés.

ANALYTIC REGULARITY FOR LINEAR ELLIPTIC SYSTEMS IN POLYGONS AND POLYHEDRA

MARTIN COSTABEL, MONIQUE DAUGE AND SERGE NICAISE

ABSTRACT. We prove weighted anisotropic analytic estimates for solutions of model elliptic boundary value problems in polyhedra. The weighted analytic classes which we use are the same as those introduced by B. Guo in 1993 in view of establishing exponential convergence for hp methods in polyhedra. We first give a simple proof of the weighted analytic regularity in a polygon, relying on new elliptic a priori estimates with analytic control of derivatives in smooth domains. The technique is based on dyadic partitions near the corners. This technique can be successfully extended to polyhedra, but only isotropic analytic regularity can be proved in this way. We therefore combine it with a nested open set technique to obtain the three-dimensional anisotropic analytic result. Our proofs are global and do not rely on the analysis of singularities.

CONTENTS

Title page	1
Introduction	2
1. Local analytic estimates in smooth domains	4
2. Local analytic estimates in plane sectors	5
2.1. Weighted spaces with homogeneous norms	6
2.2. Weighted spaces with non-homogeneous norms	8
3. Analytic weighted regularity shift in polygons	10
4. Local anisotropic analytic estimates in dihedral domains	13
4.1. Isotropic estimates: natural regularity shift	13
4.2. Tangential regularity along the edge (homogeneous norms)	14
4.3. Anisotropic estimates in dihedral domains (homogeneous norms)	18
4.4. Anisotropic estimates in dihedral domains (non-homogeneous norms)	21
5. Analytic anisotropic weighted regularity shift in polyhedra	24
5.1. Edge and corner neighborhoods	24
5.2. Anisotropic weighted spaces with homogeneous norms	26
5.3. Anisotropic weighted spaces with non-homogeneous norms	30
6. Analytic weighted regularity of variational solutions	33
6.1. Regularity of variational solutions in polygons	35
6.2. Regularity of variational solutions in polyhedra	37
7. Generalization to non-homogeneous boundary data and variable coefficients	38
7.1. Trace spaces	39

Date: February 9, 2010.

2000 Mathematics Subject Classification. 35B65, 35J25, 65N30 .

Key words and phrases. weighted anisotropic Sobolev spaces, regularity estimates.

7.2. Weighted spaces with homogeneous norms	40
7.3. Weighted spaces with non-homogeneous norms	41
7.4. Three-dimensional problems	44
8. Generalization to other operators and systems	44
References	45

INTRODUCTION

Elliptic boundary value problems in domains with corners and edges have been investigated by many authors. Let us quote the pioneering papers of V. A. Kondrat'ev [21] and of V. Maz'ya and B. Plamenevskii [24, 25, 26, 27]. In these works, the regularity of the solution and its singular behavior near edges and corners is described in terms of weighted Sobolev spaces. Besides their own theoretical interest, these results are the basis for the convergence analysis of finite element approximations of the boundary value problems. But whereas these classical results allow to prove optimal convergence estimates for the h version or the p version of the finite element method, they are not sufficient for proving the (numerically observed) exponential convergence rate of the hp -version of the finite element method. Indeed, as has been shown for two-dimensional problems by I. Babuška and B. Guo in [2, 3], the convergence analysis of the hp -FEM requires the introduction of weighted spaces with analytic-type control of all derivatives, so-called “countably normed spaces”. Babuška and Guo proved corresponding regularity results for several model problems [2, 3, 14, 17].

In three-dimensional domains, as soon as *edges* are present, the hp -version introduces anisotropic refinement, performed only in the direction transverse to the edge. Thus the corresponding weighted spaces have to take this anisotropy into account. In [15, 16] Babuška and Guo have started proving such estimates in a model situation.

For three-dimensional polyhedra (containing edges and corners) Guo has introduced the corresponding relevant spaces in 1993 [13]: The anisotropy along edges has to combine with the distance to corners. Since that time, the proof that the regularity of solutions of elliptic boundary value problems with analytic right hand sides is described by these spaces has been an open problem, even for the simplest cases of the Laplace equation with Dirichlet or Neumann boundary conditions. In the error analysis of hp -FEM, such regularity estimates have been taken as an assumption [13, 18, 32].

In this paper, we first give a simple proof of the 2D result on polygons, for Dirichlet and Neumann conditions, using a dyadic partition technique. Then, relying on a nested open set technique, we prove anisotropic regularity along edges in the framework of the anisotropic weighted spaces introduced and used in [6, 7], but now with analytic-type estimates for all derivatives. Combining the previous two steps with a 3D dyadic partition technique at polyhedral corners, we obtain the desired analytic weighted regularity in a 3D polyhedron.

We use two types of weighted spaces of analytic functions. The first type is constructed from weighted Sobolev spaces of Kondrat'ev type. These spaces with “homogeneous norms” are suitable for the description of the regularity in the presence of Dirichlet boundary conditions. For Neumann conditions, a new class of weighted analytic function

spaces, constructed from Maz'ya-Plamenevskii-type weighted Sobolev spaces with “non-homogeneous norms”, has to be used.

It is important to notice that the above spaces naturally contain the singular parts of solutions, and give an accurate account of their generic regularity. Thus, in contrast with investigations such as [19], we do not need to address separately vertex, edge and edge-vertex singularities. Our estimates cover regular and singular parts at the same time.

Our proof of analytic regularity estimates is modular in the sense that it starts from low-regularity a-priori estimates on smooth domains and proceeds to singular points, edges, and finally polyhedral corners by employing the two techniques of dyadic partitions and nested open sets. In order to avoid drowning this clear structure in too many technical difficulties, we mainly restrict ourselves to the situation of homogeneous elliptic equations with constant coefficients. Generalizations to operators with lower order terms and variable coefficients will be briefly indicated. They will be discussed in more detail in our forthcoming book [9].

PLAN OF THE PAPER

In section 1 we quote from [10] an elliptic a priori estimate with analytic control of derivatives. This estimate improves the readability and efficiency of classical proofs of analytic regularity in smooth domains as can be found in [31, 30, 23]. We refine this estimate in view of tackling problems of Neumann type. In section 2, we make use of a dyadic partition technique to construct weighted analytic estimates in plane sectors. This technique is a powerful tool to prove what we call *natural regularity shift* results near corners. This expression means that from two ingredients, namely *basic* regularity, i.e. a certain weighted Sobolev regularity of low order, of the *solution*, and *improved* regularity, i.e. high order weighted Sobolev regularity or weighted analytic regularity of the *right hand side*, one deduces improved regularity of the solution. The technique of dyadic partitions has been used in a similar framework in [4] for weighted Gevrey regularity. It has been employed earlier for domains with edges [26] and for the Laplace operator on a polygon with non-linear boundary conditions [20]. In section 3, we combine the local estimates to obtain the analytical regularity shift in polygons.

In section 4 we start the three-dimensional investigation with estimates along an edge. We introduce anisotropic weighted spaces in which derivatives along the direction of the edge are less singular towards the edge. Under the assumption of a certain local a priori estimate of low order at the neighborhood of an edge point, we prove local analytic anisotropic regularity shift along this edge, by combining dyadic partition technique and the classical (and delicate) tool of nested open sets. In section 5, we treat polyhedral corners. Relying on suitable definitions of various families of weighted spaces with anisotropy along edges (as in [29]) we are able to prove the analytic regularity shift for polyhedra by dyadic partitions around each corner of a polyhedron.

In section 6, we combine our analytic regularity shift results with known estimates giving basic regularity of the solution for the case of problems in variational form. On polygons, we use for this purpose Kondrat'ev's classical regularity results in weighted Sobolev spaces, and on polyhedra, we use recent regularity results by Maz'ya and Rossmann [29]. In this way, we finally obtain the weighted analytic regularity of variational solutions in the

right functional classes of [13]. For polygons, we thus prove again in a different and simpler way results which were first established by Babuška and Guo [2, 14]. For polyhedra, the results are new.

We conclude our paper in sections 7 and 8 by discussing various generalizations of our results. For our proofs, we choose in this paper the simplest possible framework of second order homogeneous systems with constant coefficients and zero boundary data on domains with piecewise straight or plane boundaries. In dimension 2, it is a mere technicality to generalize these proofs to the case of second order elliptic systems with analytic coefficients and non-zero boundary data. In dimension 3, the possible variation of coefficients along edges introduces more serious complications and would require to estimate commutators in a systematic way as in [10, Lemmas 1.6.2 & 2.6.2]. In comparison, the generalization to homogeneous transmission problems with constant coefficients on a polyhedral partition would be much less difficult. Whereas the Stokes system could be considered similarly, things are different for regularized harmonic Maxwell equations, for which it is necessary to detach the first singularity if one wants to obtain a valuable result, see [11] in dimension two.

We denote by $H^m(\Omega)$ the usual Hilbert Sobolev space of exponent m , by $\|\cdot\|_{m;\Omega}$ and $|\cdot|_{m;\Omega}$ its norm and semi-norm. The $L^2(\Omega)$ -norm is denoted by $\|\cdot\|_{0;\Omega}$ or simply by $\|\cdot\|_{\Omega}$. Boldface letters like $\mathbf{H}^m(\Omega)$ indicate spaces of vector functions.

1. LOCAL ANALYTIC ESTIMATES IN SMOOTH DOMAINS

The starting and key point is a local analytic estimate in smooth domains that is proved by using nested open sets on model problems and a Faà di Bruno formula for local maps, see [10, Theorem 2.7.1] for details.

Theorem 1.1. *Let Ω be a bounded domain in \mathbb{R}^n , $n \geq 2$. Let Γ be an analytic part of the boundary of Ω . Let L be a $N \times N$ elliptic system of second order operators with analytic coefficients over $\Omega \cup \Gamma$. Let $\{T, D\}$ be a set of boundary operators on Γ of order 1 and 0, respectively, with analytic coefficients, satisfying the Shapiro-Lopatinskii covering condition with respect to L on Γ . Let two bounded subdomains $\widehat{\Omega} = \mathcal{U} \cap \Omega$ and $\widehat{\Omega}' = \mathcal{U}' \cap \Omega$ be given with \mathcal{U} and \mathcal{U}' open in \mathbb{R}^n and $\overline{\mathcal{U}} \subset \mathcal{U}'$. We assume that $\widehat{\Gamma}' := \partial\widehat{\Omega}' \cap \partial\Omega$ is contained in Γ . Then there exists a constant A such that any $\mathbf{u} \in \mathbf{H}^2(\widehat{\Omega})$ satisfies for all $k \in \mathbb{N}$, $k \geq 2$, the improved a priori estimates (“finite analytic estimates”)*

$$(1.1) \quad \frac{1}{k!} |\mathbf{u}|_{k;\widehat{\Omega}} \leq A^{k+1} \left\{ \sum_{\ell=0}^{k-2} \frac{1}{\ell!} \left(|L\mathbf{u}|_{\ell;\widehat{\Omega}'} + \|T\mathbf{u}\|_{\ell+\frac{1}{2};\widehat{\Gamma}'} + \|D\mathbf{u}\|_{\ell+\frac{3}{2};\widehat{\Gamma}'} \right) + \|\mathbf{u}\|_{1;\widehat{\Omega}'} \right\}.$$

For boundary value problems of Neumann type, it will be convenient to replace in the right-hand side of (1.1) the H^1 -norm by the H^1 -semi-norm. When L , T and D are homogeneous with constant coefficients, this version is a consequence of the previous result, obtained by a simple argument based on the Bramble-Hilbert lemma. In the following statement, we present a general version of such estimates using semi-norms in the right-hand side.

Corollary 1.2. *We assume that the operators L , T and D are homogeneous with constant coefficients. Let $m \geq 1$. There exists a constant A independent of k such that there hold the following estimates for all $k \geq m$ and all \mathbf{u} satisfying the zero boundary conditions $T\mathbf{u} = 0$ and $D\mathbf{u} = 0$ on $\hat{\Gamma}$:*

$$(1.2) \quad \frac{1}{k!} |\mathbf{u}|_{k; \hat{\Omega}} \leq A^{k+1} \left\{ \sum_{\ell=m-1}^{k-2} \frac{1}{\ell!} |L\mathbf{u}|_{\ell; \hat{\Omega}'} + |\mathbf{u}|_{m; \hat{\Omega}'} \right\}.$$

Proof. We start with any $\mathbf{u} \in \mathbf{H}^k(\hat{\Omega}')$ and use estimate (1.1). We split the right hand side of the inequality into two pieces according to:

$$\sum_{\ell=0}^{k-2} \frac{1}{\ell!} \left(|L\mathbf{u}|_{\ell; \hat{\Omega}'} + \|T\mathbf{u}\|_{\ell+\frac{1}{2}; \hat{\Gamma}'} + \|D\mathbf{u}\|_{\ell+\frac{3}{2}; \hat{\Gamma}'} \right) + \|\mathbf{u}\|_{1; \hat{\Omega}'} = B^*(\mathbf{u}) + B_*(\mathbf{u})$$

with

$$\begin{aligned} B^*(\mathbf{u}) &= \sum_{\ell=m-1}^{k-2} \frac{1}{\ell!} \left(|L\mathbf{u}|_{\ell; \hat{\Omega}'} + |T\mathbf{u}|_{\ell+\frac{1}{2}; \hat{\Gamma}'} + \sum_{j=m-1}^{\ell} |T\mathbf{u}|_{j; \hat{\Gamma}'} + |D\mathbf{u}|_{\ell+\frac{3}{2}; \hat{\Gamma}'} + \sum_{j=m}^{\ell+1} |D\mathbf{u}|_{j; \hat{\Gamma}'} \right) \\ B_*(\mathbf{u}) &= \sum_{\ell=0}^{m-2} \frac{1}{\ell!} \left(|L\mathbf{u}|_{\ell; \hat{\Omega}'} + |T\mathbf{u}|_{\ell+\frac{1}{2}; \hat{\Gamma}'} + |D\mathbf{u}|_{\ell+\frac{3}{2}; \hat{\Gamma}'} \right) \\ &\quad + \sum_{\ell=0}^{k-2} \frac{1}{\ell!} \left(\sum_{j=0}^{\min\{\ell, m-2\}} |T\mathbf{u}|_{j; \hat{\Gamma}'} + \sum_{j=0}^{\min\{\ell+1, m-1\}} |D\mathbf{u}|_{j; \hat{\Gamma}'} \right) + \|\mathbf{u}\|_{1; \hat{\Omega}'} \end{aligned}$$

Since the orders of L , T and D are 2, 1 and 0 respectively, we obtain

$$B_*(\mathbf{u}) \leq C_m \|\mathbf{u}\|_{m; \hat{\Omega}'}$$

Since, moreover, the operators L , T and D are homogeneous, we have the invariance of $B^*(\mathbf{u})$ by subtraction of polynomials of degree less than $m-1$

$$B^*(\mathbf{u} - \varphi) = B^*(\mathbf{u}), \quad \forall \varphi \in \mathbb{P}^{m-1}(\hat{\Omega}').$$

Altogether, using (1.1) for $\mathbf{u} - \varphi$ we obtain for all $k \geq m$

$$\frac{1}{k!} |\mathbf{u}|_{k; \hat{\Omega}} \leq A^{k+1} \{ B^*(\mathbf{u}) + C_m \|\mathbf{u} - \varphi\|_{m; \hat{\Omega}'} \}, \quad \forall \varphi \in \mathbb{P}^{m-1}(\hat{\Omega}').$$

With the Bramble-Hilbert lemma [5], this gives

$$\frac{1}{k!} |\mathbf{u}|_{k; \hat{\Omega}} \leq A^{k+1} \{ B^*(\mathbf{u}) + C'_m |\mathbf{u}|_{m; \hat{\Omega}'} \}.$$

Applying this to functions \mathbf{u} satisfying zero boundary conditions, we obtain (1.2). \square

2. LOCAL ANALYTIC ESTIMATES IN PLANE SECTORS

The model singular domains in two dimensions are the infinite plane sectors. Let \mathcal{K} be an infinite sector with vertex at the coordinate origin $\mathbf{0} = (0, 0)$. In polar coordinates (r, θ) such a sector can be described as

$$(2.1) \quad \mathcal{K} = \{ \mathbf{x} \in \mathbb{R}^2 : \omega_1 < \theta < \omega_2 \},$$

where $\omega_2 = \omega_1 + \omega$ with $\omega_1 \in (-\pi, \pi)$ and $\omega \in (0, 2\pi]$ is the opening of the sector \mathcal{K} . For $i = 1, 2$, let Γ_i be the side $\theta = \omega_i$ of \mathcal{K} .

We consider an elliptic system of order 2, homogeneous with constant coefficients, covered on each side Γ_i by a set $\{T_i, D_i\}$ of boundary conditions. For any subdomain \mathcal{W}' of \mathcal{K} , we consider the system of local interior and boundary equations

$$(2.2) \quad \begin{cases} L\mathbf{u} = \mathbf{f} & \text{in } \mathcal{K} \cap \mathcal{W}', \\ T_i \mathbf{u} = 0 & \text{on } \Gamma_i \cap \overline{\mathcal{W}'}, \quad i = 1, 2, \\ D_i \mathbf{u} = 0 & \text{on } \Gamma_i \cap \overline{\mathcal{W}'}, \quad i = 1, 2, \end{cases}$$

which is the localization to \mathcal{W}' of the elliptic boundary value problem $L\mathbf{u} = \mathbf{f}$ in \mathcal{K} , with zero boundary conditions on Γ_1 and Γ_2 .

2.1. Weighted spaces with homogeneous norms. These spaces coincide with those introduced by KONDRAT'EV in his pioneering study of corner problems [21]. The weight depends on the order of the derivatives. We adopt a different convention than [21] in our notation in order to make the definition of corresponding analytic classes more natural (see (3.6) below).

Definition 2.1. Let β be a real number called the *weight exponent*, and let $m \geq 0$ be an integer called the *Sobolev exponent*. Let \mathcal{W} be a subdomain of \mathcal{K} .

The *weighted space with homogeneous norm* $\mathbf{K}_\beta^m(\mathcal{W})$ is defined, with the distance $r = |\mathbf{x}|$ to the vertex $\mathbf{0}$, by

$$(2.3) \quad \mathbf{K}_\beta^m(\mathcal{W}) = \{u \in \mathbf{L}_{\text{loc}}^2(\mathcal{W}) : r^{\beta+|\alpha|} \partial_{\mathbf{x}}^\alpha u \in \mathbf{L}^2(\mathcal{W}), \quad \forall \alpha, |\alpha| \leq m\}$$

and endowed with semi-norm and norm respectively defined as

$$(2.4) \quad |u|_{m,\beta;\mathcal{W}}^2 = \sum_{|\alpha|=m} \|r^{\beta+|\alpha|} \partial_{\mathbf{x}}^\alpha u\|_{0;\mathcal{W}}^2 \quad \text{and} \quad \|u\|_{\mathbf{K}_\beta^m(\mathcal{W})}^2 = \sum_{k=0}^m |u|_{k,\beta;\mathcal{W}}^2.$$

Theorem 2.2. Let \mathcal{W} and \mathcal{W}' be the intersections of \mathcal{K} with the balls centered at $\mathbf{0}$ of radii 1 and $1 + \delta$, respectively. Let $\beta \in \mathbb{R}$ and $n \in \mathbb{N}$. Let $\mathbf{u} \in \mathbf{H}_{\text{loc}}^2(\overline{\mathcal{W}'}) \setminus \{\mathbf{0}\}$ be a solution of problem (2.2). Then the following implication holds

$$(2.5) \quad \mathbf{u} \in \mathbf{K}_\beta^1(\mathcal{W}') \quad \text{and} \quad \mathbf{f} \in \mathbf{K}_{\beta+2}^n(\mathcal{W}') \quad \implies \quad \mathbf{u} \in \mathbf{K}_\beta^{n+2}(\mathcal{W})$$

and there exists a constant $C \geq 1$ independent of \mathbf{u} and n such that for any integer k , $0 \leq k \leq n + 2$, we have

$$(2.6) \quad \frac{1}{k!} \left(\sum_{|\alpha|=k} \|r^{\beta+|\alpha|} \partial_{\mathbf{x}}^\alpha \mathbf{u}\|_{0;\mathcal{W}}^2 \right)^{\frac{1}{2}} \leq C^{k+1} \left\{ \sum_{\ell=0}^{k-2} \frac{1}{\ell!} \left(\sum_{|\alpha|=\ell} \|r^{\beta+2+|\alpha|} \partial_{\mathbf{x}}^\alpha \mathbf{f}\|_{0;\mathcal{W}'}^2 \right)^{\frac{1}{2}} + \sum_{|\alpha| \leq 1} \|r^{\beta+|\alpha|} \partial_{\mathbf{x}}^\alpha \mathbf{u}\|_{0;\mathcal{W}'} \right\}.$$

Proof. Let us assume that $\mathbf{u} \in \mathbf{K}_\beta^1(\mathcal{W}')$ and $L\mathbf{u} = \mathbf{f} \in \mathbf{K}_{\beta+2}^n(\mathcal{W}')$. Let us prove estimate (2.6). By definition of the weighted spaces, the right-hand side of (2.6) is bounded. The

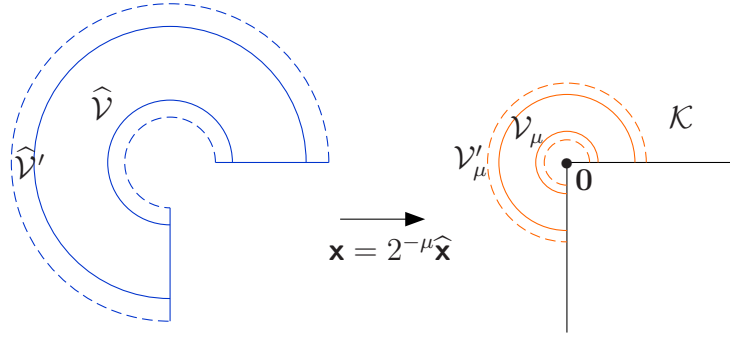

FIGURE 1. Reference and scaled annuli for a sector \mathcal{K} of opening $3\pi/2$

proof of the estimate is based on a locally finite dyadic covering of \mathcal{W} and \mathcal{W}' . Let us introduce the reference annuli, see Fig. 1

$$(2.7) \quad \widehat{\mathcal{V}} = \{\mathbf{x} \in \mathcal{K} : \frac{1}{4} < r(\mathbf{x}) < 1\} \quad \text{and} \quad \widehat{\mathcal{V}}' = \{\mathbf{x} \in \mathcal{K} : \frac{1}{4} - \delta < r(\mathbf{x}) < 1 + \delta\}.$$

and for $\mu \in \mathbb{N}$ the scaled annuli:

$$\mathcal{V}_{\mu} = 2^{-\mu}\widehat{\mathcal{V}} \quad \text{and} \quad \mathcal{V}'_{\mu} = 2^{-\mu}\widehat{\mathcal{V}}'.$$

We check immediately that

$$\mathcal{W} = \bigcup_{\mu \in \mathbb{N}} \mathcal{V}_{\mu} \quad \text{and} \quad \mathcal{W}' = \bigcup_{\mu \in \mathbb{N}} \mathcal{V}'_{\mu}.$$

STEP 1. We are going to apply Theorem 1.1 in two regions which separate the two sides Γ_1 and Γ_2 of \mathcal{K} where the boundary conditions can be distinct. We recall that the sector \mathcal{K} is defined by the angular inequalities $\omega_1 < \theta < \omega_2$. Let $\omega_3 := \frac{1}{2}(\omega_1 + \omega_2)$. We define the sectors \mathcal{K}_1 and \mathcal{K}_2 by

$$\mathcal{K}_1 = \{\mathbf{x} \in \mathbb{R}^2 : \omega_1 < \theta < \omega_3\} \quad \text{and} \quad \mathcal{K}_2 = \{\mathbf{x} \in \mathbb{R}^2 : \omega_3 < \theta < \omega_2\}.$$

Let $\delta < \frac{1}{2}(\omega_2 - \omega_1)$. We define the larger sectors \mathcal{K}'_1 and \mathcal{K}'_2 by

$$\mathcal{K}'_1 = \{\mathbf{x} \in \mathbb{R}^2 : \omega_1 < \theta < \omega_3 + \delta\} \quad \text{and} \quad \mathcal{K}'_2 = \{\mathbf{x} \in \mathbb{R}^2 : \omega_3 - \delta < \theta < \omega_2\}.$$

Let $i \in \{1, 2\}$. Since the system L is elliptic and covered by its boundary conditions $\{T_i, D_i\}$ on Γ_i , the reference domains $\widehat{\mathcal{V}} \cap \mathcal{K}_i$ and $\widehat{\mathcal{V}}' \cap \mathcal{K}'_i$ satisfy the assumptions of Theorem 1.1, and there exists a positive constant A_i such that for all $k \in \mathbb{N}, k \geq 2$, we have:

$$(2.8) \quad \frac{1}{k!} |\widehat{\mathbf{u}}|_{k; \widehat{\mathcal{V}} \cap \mathcal{K}_i} \leq A_i^{k+1} \left\{ \sum_{\ell=0}^{k-2} \frac{1}{\ell!} |\widehat{\mathbf{f}}|_{\ell; \widehat{\mathcal{V}}' \cap \mathcal{K}'_i} + \sum_{\ell=0}^1 |\widehat{\mathbf{u}}|_{\ell; \widehat{\mathcal{V}}' \cap \mathcal{K}'_i} \right\},$$

for any function $\widehat{\mathbf{u}}$ satisfying the boundary conditions of (2.2) and $\widehat{\mathbf{f}} := L\widehat{\mathbf{u}}$. From these estimates for $i = 1, 2$ we deduce immediately, with $A = \max\{A_1, A_2\}$

$$(2.9) \quad \frac{1}{k!} |\widehat{\mathbf{u}}|_{k; \widehat{\mathcal{V}}} \leq 2A^{k+1} \left\{ \sum_{\ell=0}^{k-2} \frac{1}{\ell!} |\widehat{\mathbf{f}}|_{\ell; \widehat{\mathcal{V}'}} + \sum_{\ell=0}^1 |\widehat{\mathbf{u}}|_{\ell; \widehat{\mathcal{V}'}} \right\},$$

STEP 2. Since $r(\widehat{\mathbf{x}}) \simeq 1$ on $\widehat{\mathcal{V}'}$, we can insert weights in the reference estimate (2.9): There exists a positive constant B such that for all $k \in \mathbb{N}, k \geq 2$

$$(2.10) \quad \frac{1}{k!} \left(\sum_{|\alpha|=k} \|r(\widehat{\mathbf{x}})^{\beta+|\alpha|} \partial_{\widehat{\mathbf{x}}}^{\alpha} \widehat{\mathbf{u}}\|_{0; \widehat{\mathcal{V}}}^2 \right)^{\frac{1}{2}} \leq B^{k+1} \left\{ \sum_{\ell=0}^{k-2} \frac{1}{\ell!} \left(\sum_{|\alpha|=\ell} \|r(\widehat{\mathbf{x}})^{\beta+2+|\alpha|} \partial_{\widehat{\mathbf{x}}}^{\alpha} \widehat{\mathbf{f}}\|_{0; \widehat{\mathcal{V}'}}^2 \right)^{\frac{1}{2}} + \sum_{|\alpha| \leq 1} \|r(\widehat{\mathbf{x}})^{\beta+|\alpha|} \partial_{\widehat{\mathbf{x}}}^{\alpha} \widehat{\mathbf{u}}\|_{0; \widehat{\mathcal{V}'}} \right\}.$$

By the change of variables $\widehat{\mathbf{x}} \rightarrow \mathbf{x} = 2^{-\mu} \widehat{\mathbf{x}}$ that maps $\widehat{\mathcal{V}}$ onto \mathcal{V}_{μ} (resp. $\widehat{\mathcal{V}'}$ onto \mathcal{V}'_{μ}) coupled with the change of functions

$$\widehat{\mathbf{u}}(\widehat{\mathbf{x}}) := \mathbf{u}(\mathbf{x}) \quad \text{and} \quad \widehat{\mathbf{f}}(\widehat{\mathbf{x}}) := L\widehat{\mathbf{u}} \quad \text{which implies} \quad \widehat{\mathbf{f}}(\widehat{\mathbf{x}}) = 2^{-2\mu} \mathbf{f}(\mathbf{x}),$$

we deduce from estimate (2.10) that

$$\begin{aligned} \frac{1}{k!} 2^{\mu\beta-\mu} \left(\sum_{|\alpha|=k} \|r(\mathbf{x})^{\beta+|\alpha|} \partial_{\mathbf{x}}^{\alpha} \mathbf{u}\|_{0; \mathcal{V}_{\mu}}^2 \right)^{\frac{1}{2}} &\leq B^{k+1} \left\{ \right. \\ &\sum_{\ell=0}^{k-2} \frac{1}{\ell!} 2^{\mu(\beta+2)-\mu} \left(\sum_{|\alpha|=\ell} 2^{-2\mu} \|r(\mathbf{x})^{\beta+2+|\alpha|} \partial_{\mathbf{x}}^{\alpha} \mathbf{f}\|_{0; \mathcal{V}'_{\mu}}^2 \right)^{\frac{1}{2}} + 2^{\mu\beta-\mu} \sum_{|\alpha| \leq 1} \|r(\mathbf{x})^{\beta+|\alpha|} \partial_{\mathbf{x}}^{\alpha} \mathbf{u}\|_{0; \mathcal{V}'_{\mu}} \left. \right\}. \end{aligned}$$

Multiplying this identity by $2^{-\mu\beta+\mu}$, the above estimate is equivalent to

$$\begin{aligned} \frac{1}{k!} \left(\sum_{|\alpha|=k} \|r(\mathbf{x})^{\beta+|\alpha|} \partial_{\mathbf{x}}^{\alpha} \mathbf{u}\|_{0; \mathcal{V}_{\mu}}^2 \right)^{\frac{1}{2}} &\leq B^{k+1} \left(\sum_{\ell=0}^{k-2} \frac{1}{\ell!} \left(\sum_{|\alpha|=\ell} \|r(\mathbf{x})^{\beta+2+|\alpha|} \partial_{\mathbf{x}}^{\alpha} \mathbf{f}\|_{0; \mathcal{V}'_{\mu}}^2 \right)^{\frac{1}{2}} \right. \\ &\quad \left. + \sum_{|\alpha| \leq 1} \|r(\mathbf{x})^{\beta+|\alpha|} \partial_{\mathbf{x}}^{\alpha} \mathbf{u}\|_{0; \mathcal{V}'_{\mu}} \right). \end{aligned}$$

Summing up the square of this estimate over all μ and considering that only a finite number of the \mathcal{V}'_{μ} overlap, we get the desired estimate (2.6). \square

2.2. Weighted spaces with non-homogeneous norms. In these spaces the weight exponent does not depend on the order of derivatives. Standard unweighted Sobolev spaces are a special case. The weighted Sobolev spaces with nonhomogeneous norms allow an accurate description of the regularity of functions with non-trivial Taylor expansion at the corners. In particular, they are useful for studying variational problems of Neumann type, because the variational space H^1 does not fit properly into the scale K_{β}^1 .

Definition 2.3. Let β be a real number and $m \geq 0$ an integer.

Let \mathcal{W} be a subdomain of \mathcal{K} . The *weighted space with non-homogeneous norm* $J_\beta^m(\mathcal{W})$ is defined by

$$(2.11) \quad J_\beta^m(\mathcal{W}) = \{u \in L_{\text{loc}}^2(\mathcal{W}) : r^{\beta+m} \partial_{\mathbf{x}}^\alpha u \in L^2(\mathcal{W}), \quad \forall \alpha, |\alpha| \leq m\}$$

with its norm

$$\|u\|_{J_\beta^m(\mathcal{W})}^2 = \sum_{|\alpha| \leq m} \|r^{\beta+m} \partial_{\mathbf{x}}^\alpha u\|_{0; \mathcal{W}}^2.$$

Note that the semi-norm of $J_\beta^m(\mathcal{W})$ coincides with the semi-norm of $K_\beta^m(\mathcal{W})$. They are both denoted by $|\cdot|_{m, \beta; \mathcal{W}}$. With this notation, we have

$$(2.12) \quad \|u\|_{J_\beta^m(\mathcal{W})}^2 = \sum_{k=0}^m |u|_{k, \beta+m-k; \mathcal{W}}^2.$$

We recall from [8] the ‘‘step-weighted’’ characterization of J_β^m in the case of two space dimensions:

Proposition 2.4. *Let $\beta \in \mathbb{R}$ and $m \in \mathbb{N}$ such that $\beta + m > -1$. Let σ be any real number in the interval $(-1, \beta + m]$. Then the norm in the space $J_\beta^m(\mathcal{W})$ is equivalent to*

$$(2.13) \quad \left(\sum_{|\alpha| \leq m} \|r^{\max\{\beta+|\alpha|, \sigma\}} \partial_{\mathbf{x}}^\alpha u\|_{0; \mathcal{W}}^2 \right)^{\frac{1}{2}}.$$

Corollary 2.5. *Let $\beta \in \mathbb{R}$. Let m be a natural number such that $\beta + m > -1$. Then $J_\beta^{m+1}(\mathcal{W}) \subset J_\beta^m(\mathcal{W})$.*

Theorem 2.6. *Let \mathcal{W} and \mathcal{W}' be the intersections of \mathcal{K} with the balls centered at $\mathbf{0}$ of radii 1 and $1 + \delta$, respectively. Let β be a real number and let $m \geq 1$ be an integer. We assume that $\beta + m > -1$. Let $n \geq m - 1$ be another integer. Let $\mathbf{u} \in \mathbf{H}_{\text{loc}}^2(\overline{\mathcal{W}'} \setminus \{\mathbf{0}\})$ be a solution of problem (2.2). Then the following implication holds*

$$(2.14) \quad \mathbf{u} \in \mathbf{J}_\beta^m(\mathcal{W}') \text{ and } \mathbf{f} \in \mathbf{J}_{\beta+2}^n(\mathcal{W}') \implies \mathbf{u} \in \mathbf{J}_\beta^{n+2}(\mathcal{W})$$

and there exists a constant $C \geq 1$ independent of \mathbf{u} and n such that for all integer k , $m \leq k \leq n + 2$, we have

$$(2.15) \quad \frac{1}{k!} \left(\sum_{|\alpha|=k} \|r^{\beta+|\alpha|} \partial_{\mathbf{x}}^\alpha \mathbf{u}\|_{0; \mathcal{W}}^2 \right)^{\frac{1}{2}} \leq C^{k+1} \left\{ \sum_{\ell=m-1}^{k-2} \frac{1}{\ell!} \left(\sum_{|\alpha|=\ell} \|r^{\beta+2+|\alpha|} \partial_{\mathbf{x}}^\alpha \mathbf{f}\|_{0; \mathcal{W}'}^2 \right)^{\frac{1}{2}} + \sum_{|\alpha|=m} \|r^{\beta+|\alpha|} \partial_{\mathbf{x}}^\alpha \mathbf{u}\|_{0; \mathcal{W}'} \right\}.$$

Proof. Let us assume that $\mathbf{u} \in \mathbf{J}_\beta^m(\mathcal{W}')$ is such that $\mathbf{f} \in \mathbf{J}_{\beta+2}^n(\mathcal{W}')$. Let $k, m < k \leq n + 2$. Let us prove estimate (2.15). Since $\beta + m > -1$, we have $\beta + 2 + |\alpha| > -1$ for all α with length $\geq m - 1$. Therefore, as a consequence of Proposition 2.4, the right-hand side of (2.15) is bounded.

Then, in a similar way as in the proof of Theorem 2.2, we start from estimate (1.2) written for the reference domains $\widehat{\mathcal{V}}$ and $\widehat{\mathcal{V}}'$ and we apply the same dyadic covering technique. We arrive directly at the estimate (2.15).

It remains to prove that $\mathbf{u} \in \mathbf{J}_\beta^{n+2}(\mathcal{W})$. Since \mathcal{W} is bounded, estimate (2.15) implies that $r^{\beta+n+2}\partial_{\mathbf{x}}^\alpha \mathbf{u}$ belongs to $\mathbf{L}^2(\mathcal{W})$ for all α , $m \leq |\alpha| \leq n+2$. Since $\mathbf{u} \in \mathbf{J}_\beta^m(\mathcal{W}')$, we deduce that $r^{\beta+n+2}\partial_{\mathbf{x}}^\alpha \mathbf{u}$ also belongs to $\mathbf{L}^2(\mathcal{W})$ when $|\alpha| < m$, which ends the proof. \square

3. ANALYTIC WEIGHTED REGULARITY SHIFT IN POLYGONS

Let Ω be a polygonal domain. This means that the boundary of Ω is the union of a finite number of line segments (the sides $\Gamma_{\mathbf{s}}$, for indices $\mathbf{s} \in \mathcal{S}$). We do not assume that Ω is a Lipschitz domain, that is we include the presence of cracks in our analysis. The vertices \mathbf{c} are the ends of the edges. Let us denote by \mathcal{C} the set of vertices and

$$(3.1) \quad r_{\mathbf{c}}(\mathbf{x}) = \text{dist}(\mathbf{x}, \mathbf{c}).$$

There exists $\varepsilon > 0$ such that, setting

$$(3.2a) \quad \Omega_{\mathbf{c}} = \{\mathbf{x} \in \Omega : r_{\mathbf{c}} < \varepsilon\},$$

we have

$$(3.2b) \quad \overline{\Omega}_{\mathbf{c}} \cap \overline{\Omega}_{\mathbf{c}'} = \emptyset, \quad \forall \mathbf{c} \neq \mathbf{c}'.$$

Choosing $\varepsilon'' < \varepsilon$ and setting $\Omega_{\mathbf{c}}'' = \{\mathbf{x} \in \Omega : r_{\mathbf{c}} < \varepsilon''\}$, we define

$$(3.2c) \quad \Omega_0 = \Omega \setminus \bigcup_{\mathbf{c} \in \mathcal{C}} \overline{\Omega}_{\mathbf{c}}''.$$

We also define larger neighborhoods choosing $\varepsilon' > \varepsilon$ such that

$$(3.2d) \quad \Omega'_{\mathbf{c}} = \{\mathbf{x} \in \Omega : r_{\mathbf{c}} < \varepsilon'\}, \quad \overline{\Omega}'_{\mathbf{c}} \cap \overline{\Omega}'_{\mathbf{c}'} = \emptyset, \quad \forall \mathbf{c} \neq \mathbf{c}',$$

and we finally set

$$(3.2e) \quad \Omega'_0 = \Omega \setminus \bigcup_{\mathbf{c} \in \mathcal{C}} \overline{\Omega}_{\mathbf{c}}.$$

For each corner there is a plane sector $\mathcal{K}_{\mathbf{c}}$ with vertex $\mathbf{0}$ such that the translation $\mathbf{x} \mapsto \mathbf{x} - \mathbf{c}$ sends $\Omega_{\mathbf{c}}$ onto $\mathcal{K}_{\mathbf{c}} \cap \mathcal{B}(\mathbf{0}, \varepsilon)$.

Let $\underline{\beta} = (\beta_{\mathbf{c}})_{\mathbf{c} \in \mathcal{C}} \in \mathbb{R}^{\#\mathcal{C}}$ be a weight multi-exponent and $m \in \mathbb{N}$ a Sobolev exponent. By localization we define the weighted semi-norm on any domain $\mathcal{V} \subset \Omega$:

$$(3.3) \quad |u|_{m, \underline{\beta}; \mathcal{V}}^2 = \sum_{|\alpha|=m} \left(\|\partial_{\mathbf{x}}^\alpha u\|_{0; \mathcal{V} \cap \Omega_0}^2 + \sum_{\mathbf{c} \in \mathcal{C}} \|r_{\mathbf{c}}^{\beta_{\mathbf{c}}+|\alpha|} \partial_{\mathbf{x}}^\alpha u\|_{0; \mathcal{V} \cap \Omega_{\mathbf{c}}}^2 \right),$$

and the norms, cf. (2.4) and (2.12)

$$(3.4) \quad \|u\|_{\mathbf{K}_{\underline{\beta}}^m(\mathcal{V})}^2 = \sum_{k=0}^m |u|_{k, \underline{\beta}; \mathcal{V}}^2 \quad \text{and} \quad \|u\|_{\mathbf{J}_{\underline{\beta}}^m(\Omega)}^2 = \sum_{k=0}^m |u|_{k, \underline{\beta}+m-k; \mathcal{V}}^2,$$

defining the spaces $\mathbf{K}_{\underline{\beta}}^m(\mathcal{V})$ and $\mathbf{J}_{\underline{\beta}}^m(\mathcal{V})$, respectively. If all weight exponents $\beta_{\mathbf{c}}$ coincide with the same number β , these spaces are simply denoted by $\mathbf{K}_\beta^m(\mathcal{V})$ and $\mathbf{J}_\beta^m(\mathcal{V})$, respectively. Boldface notations $\mathbf{K}_{\underline{\beta}}^m(\mathcal{V})$ and $\mathbf{J}_{\underline{\beta}}^m(\mathcal{V})$ indicate vector-valued functions.

Remark 3.1. The semi-norm $|u|_{m,\underline{\beta};\Omega}$ is equivalent to the globally defined semi-norm

$$(3.5) \quad \left\{ \sum_{|\alpha|=m} \left\| \left(\prod_{\mathbf{c} \in \mathcal{C}} r_{\mathbf{c}}^{\beta_{\mathbf{c}}+|\alpha|} \right) \partial_{\mathbf{x}}^{\alpha} u \right\|_{0;\Omega}^2 \right\}^{\frac{1}{2}}.$$

We define on any domain $\mathcal{V} \subset \Omega$ the corresponding weighted analytic classes.

(i) With homogeneous norm:

$$(3.6) \quad A_{\underline{\beta}}(\mathcal{V}) = \left\{ u \in \bigcap_{m \geq 0} K_{\underline{\beta}}^m(\mathcal{V}) : \exists C > 0, \forall m \in \mathbb{N}, |u|_{m,\underline{\beta};\mathcal{V}} \leq C^{m+1} m! \right\}.$$

(ii) With non-homogeneous norm: For a multi-exponent $\underline{\beta}$ let

$$(3.7) \quad \eta := \max_{\mathbf{c} \in \mathcal{C}} -\beta_{\mathbf{c}} - 1.$$

As a consequence of Proposition 2.4, for all $m > \eta$ we have the continuous embedding of $J_{\underline{\beta}}^{m+1}(\mathcal{V})$ into $J_{\underline{\beta}}^m(\mathcal{V})$. We introduce

$$(3.8) \quad B_{\underline{\beta}}(\mathcal{V}) = \left\{ u \in \bigcap_{m > \eta} J_{\underline{\beta}}^m(\mathcal{V}) : \exists C > 0, \forall m > \eta, |u|_{m,\underline{\beta};\mathcal{V}} \leq C^{m+1} m! \right\}.$$

Remark 3.2. (i) The classes $A_{\underline{\beta}}(\Omega)$ and $B_{\underline{\beta}}(\Omega)$ can be equivalently defined replacing semi-norms $|u|_{m,\underline{\beta};\Omega}$ by the global semi-norms (3.5).

(ii) The classes $A_{\underline{\beta}}(\Omega)$ can also be equivalently defined locally i.e.

$$A_{\underline{\beta}}(\Omega) = \{ u \in L_{\text{loc}}^2(\Omega) : u|_{\Omega_0} \in A(\Omega_0) \text{ and } u|_{\Omega_{\mathbf{c}}} \in A_{\beta_{\mathbf{c}}}(\Omega_{\mathbf{c}}) \forall \mathbf{c} \in \mathcal{C} \}.$$

Here $A(\Omega_0)$ is the unweighted class of analytic functions on Ω_0 . The spaces $B_{\underline{\beta}}(\Omega)$ allow analogous local descriptions.

Remark 3.3. (i) Our spaces $B_{\beta}(\Omega)$ coincide with the family of *countably normed spaces* $B_{\beta}^{\ell}(\Omega)$, introduced by Babuška and Guo [2]: The spaces $B_{\beta}^{\ell}(\Omega)$ are defined for $\ell \in \mathbb{N}$ and $0 < \beta < 1$, and there holds

$$(3.9) \quad B_{\beta}^{\ell}(\Omega) = B_{\beta-\ell}(\Omega).$$

(ii) The relation between the classes $A_{\underline{\beta}}(\Omega)$ and $B_{\underline{\beta}}(\Omega)$ follows from the relation between the weighted spaces with homogeneous and nonhomogeneous norms $K_{\underline{\beta}}^m(\Omega)$ and $J_{\underline{\beta}}^m(\Omega)$. On the finite sector $\Omega_{\mathbf{c}}$ there holds [27, 22] (more details are given in [8] and [9, Ch. 11]):

If $\beta > -1$, then $J_{\beta}^m(\Omega_{\mathbf{c}}) = K_{\beta}^m(\Omega_{\mathbf{c}})$ for all $m \in \mathbb{N}$.

If $\beta \leq -1$ and $m \leq -\beta - 1$, then, again, $J_{\beta}^m(\Omega_{\mathbf{c}}) = K_{\beta}^m(\Omega_{\mathbf{c}})$.

If $\beta \leq -1$ and $m > -\beta - 1$, then one has to distinguish two cases:

- the generic case $-\beta \notin \mathbb{N}$, in which one has

$$J_{\beta}^m(\Omega_{\mathbf{c}}) = K_{\beta}^m(\Omega_{\mathbf{c}}) \oplus \mathbb{P}^{[-\beta-1]}$$

where $\mathbb{P}^{[-\beta-1]}$ is the space of polynomials of degree not exceeding $-\beta - 1$;

- the *critical* case $-\beta \in \mathbb{N}$, in which $J_{\beta}^m(\Omega_{\mathbf{c}})$ contains $K_{\beta}^m(\Omega_{\mathbf{c}}) \oplus \mathbb{P}^{-\beta-1}$ as a strict subspace.

As a consequence it follows that for $\beta > -1$ there holds $B_\beta(\Omega_{\mathbf{c}}) = A_\beta(\Omega_{\mathbf{c}})$, whereas for $\beta \leq -1$ one has in the non-critical case $-\beta \notin \mathbb{N}$:

$$(3.10) \quad B_\beta(\Omega_{\mathbf{c}}) = A_\beta(\Omega_{\mathbf{c}}) \oplus \mathbb{P}^{[-\beta-1]}$$

and in the *critical* case $-\beta \in \mathbb{N}$: $B_\beta(\Omega_{\mathbf{c}})$ contains $A_\beta(\Omega_{\mathbf{c}}) \oplus \mathbb{P}^{-\beta-1}$ as a strict subspace.

We consider a ‘‘mixed’’ boundary value problem on the polygonal domain Ω : We suppose that we are given an homogeneous second order elliptic system L with constant coefficients and for each side \mathbf{s} a covering set of boundary operators $\{T_{\mathbf{s}}, D_{\mathbf{s}}\}$ of order 1 and 0, homogeneous with constant coefficients. The boundary value problem under consideration is:

$$(3.11) \quad \begin{cases} L \mathbf{u} = \mathbf{f} & \text{in } \Omega, \\ T_{\mathbf{s}} \mathbf{u} = 0 & \text{on } \Gamma_{\mathbf{s}}, \mathbf{s} \in \mathcal{S}, \\ D_{\mathbf{s}} \mathbf{u} = 0 & \text{on } \Gamma_{\mathbf{s}}, \mathbf{s} \in \mathcal{S}. \end{cases}$$

Note that one of $T_{\mathbf{s}}$ or $D_{\mathbf{s}}$ may be the zero operator, in which case the corresponding boundary condition is empty.

We can now prove the following statement of natural regularity shift in weighted analytic spaces with homogeneous or non-homogeneous semi-norms:

Theorem 3.4. *Let $\underline{\beta} = (\beta_{\mathbf{c}})_{\mathbf{c} \in \mathcal{C}}$ be a weight multi-exponent. Let $\mathbf{u} \in \mathbf{H}_{\text{loc}}^2(\overline{\Omega} \setminus \mathcal{C})$ be a solution of problem (3.11).*

(i) *The following implications hold*

$$(3.12a) \quad \mathbf{u} \in \mathbf{K}_{\underline{\beta}}^1(\Omega) \text{ and } \mathbf{f} \in \mathbf{K}_{\underline{\beta}+2}^n(\Omega) \implies \mathbf{u} \in \mathbf{K}_{\underline{\beta}}^{n+2}(\Omega) \quad (n \in \mathbb{N}).$$

and

$$(3.12b) \quad \mathbf{u} \in \mathbf{K}_{\underline{\beta}}^1(\Omega) \text{ and } \mathbf{f} \in \mathbf{A}_{\underline{\beta}+2}(\Omega) \implies \mathbf{u} \in \mathbf{A}_{\underline{\beta}}(\Omega).$$

(ii) *Let $m \geq 1$ be an integer such that $\beta_{\mathbf{c}} + m > -1$ for all $\mathbf{c} \in \mathcal{C}$. Then the following implications hold*

$$(3.13a) \quad \mathbf{u} \in \mathbf{J}_{\underline{\beta}}^m(\Omega) \text{ and } \mathbf{f} \in \mathbf{J}_{\underline{\beta}+2}^n(\Omega) \implies \mathbf{u} \in \mathbf{J}_{\underline{\beta}}^{n+2}(\Omega) \quad (n \in \mathbb{N}).$$

and

$$(3.13b) \quad \mathbf{u} \in \mathbf{J}_{\underline{\beta}}^m(\Omega) \text{ and } \mathbf{f} \in \mathbf{B}_{\underline{\beta}+2}(\Omega) \implies \mathbf{u} \in \mathbf{B}_{\underline{\beta}}(\Omega).$$

Proof. The finite regularity shift results in (3.12a) and (3.13a) are obvious consequences of Theorems 2.2 and 2.6. Let us prove (3.12b). The uniform estimate (2.6) is valid between $\Omega_{\mathbf{c}}$ and $\Omega'_{\mathbf{c}}$ for all $\mathbf{c} \in \mathcal{C}$. The uniform estimate (1.1) of the smooth case is valid between Ω_0 and Ω'_0 . Combining these estimates we obtain the global uniform estimate for all integer $k \geq 2$

$$\frac{1}{k!} |\mathbf{u}|_{k, \underline{\beta}; \Omega} \leq C^{k+1} \left(\sum_{\ell=0}^{k-2} \frac{1}{\ell!} |\mathbf{f}|_{\ell, \underline{\beta}+2; \Omega} + \|\mathbf{u}\|_{\mathbf{K}_{\underline{\beta}}^1(\Omega)} \right).$$

If $\mathbf{f} \in \mathbf{A}_{\beta+2}(\Omega)$, it satisfies $|\mathbf{f}|_{\ell, \underline{\beta}; \Omega} \leq F^{\ell+1} \ell!$ for some constant $F > 1$. Thus the previous estimate yields

$$|\mathbf{u}|_{k, \underline{\beta}; \Omega} \leq k! C^{k+1} \left(\sum_{\ell=0}^{k-2} F^{\ell+1} + \|\mathbf{u}\|_{\mathbf{K}_{\underline{\beta}}^1(\Omega)} \right) = k! C^{k+1} \left(\frac{F^k - F}{F - 1} + \|\mathbf{u}\|_{\mathbf{K}_{\underline{\beta}}^1(\Omega)} \right).$$

Hence $\mathbf{u} \in \mathbf{A}_{\underline{\beta}}(\Omega)$. The proof of (3.13b) is similar, based on estimate (2.15). \square

4. LOCAL ANISOTROPIC ANALYTIC ESTIMATES IN DIHEDRAL DOMAINS

Infinite dihedral domains (or wedges) are the model domains for polyhedra which have the lowest level of complexity. In this section, we consider dihedral domains \mathcal{D} in a model configuration, that is there exists a plane sector \mathcal{K} with vertex $\mathbf{0}$ so that

$$(4.1) \quad \mathcal{D} = \mathcal{K} \times \mathbb{R} \quad \text{and} \quad \mathbf{x} = (x_1, x_2, x_3) = (\mathbf{x}_{\perp}, x_3) \in \mathcal{D} \Leftrightarrow \mathbf{x}_{\perp} \in \mathcal{K}, x_3 \in \mathbb{R}.$$

The edge \mathbf{e} of the dihedral domain \mathcal{D} is the line $x_1 = x_2 = 0$.

Let \mathcal{V} be any subdomain of \mathcal{D} . We consider the system of local interior and boundary equations

$$(4.2) \quad \begin{cases} L\mathbf{u} = \mathbf{f} & \text{in } \mathcal{D} \cap \mathcal{V}, \\ T_i \mathbf{u} = 0 & \text{on } (\Gamma_i \times \mathbb{R}) \cap \overline{\mathcal{V}}, \quad i = 1, 2, \\ D_i \mathbf{u} = 0 & \text{on } (\Gamma_i \times \mathbb{R}) \cap \overline{\mathcal{V}}, \quad i = 1, 2, \end{cases}$$

where the operators L , T_i and D_i are homogeneous with constant coefficients and form an elliptic system. The system (4.2) is the localization to \mathcal{V} of the elliptic boundary value problem $L\mathbf{u} = \mathbf{f}$ in \mathcal{D} , with zero boundary conditions on $\Gamma_1 \times \mathbb{R}$ and $\Gamma_2 \times \mathbb{R}$.

4.1. Isotropic estimates: natural regularity shift. The weighted spaces for the dihedron are defined by the same formulas as in the case of a plane sector:

Definition 4.1. Let β be a real number and let $m \geq 0$ be an integer. Let $\mathcal{W} \subset \mathcal{D}$.

The *isotropic weighted spaces* $\mathbf{K}_{\beta}^m(\mathcal{W})$ and $\mathbf{J}_{\beta}^m(\mathcal{W})$ are defined, with the distance $r := |\mathbf{x}_{\perp}| = \sqrt{x_1^2 + x_2^2}$ to the edge \mathbf{e} , by

$$\begin{aligned} \mathbf{K}_{\beta}^m(\mathcal{W}) &= \{u \in \mathbf{L}_{\text{loc}}^2(\mathcal{W}) : r^{\beta+|\alpha|} \partial_{\mathbf{x}}^{\alpha} u \in \mathbf{L}^2(\mathcal{W}), \quad \forall \alpha, |\alpha| \leq m\} \\ \mathbf{J}_{\beta}^m(\mathcal{W}) &= \{u \in \mathbf{L}_{\text{loc}}^2(\mathcal{W}) : r^{\beta+m} \partial_{\mathbf{x}}^{\alpha} u \in \mathbf{L}^2(\mathcal{W}), \quad \forall \alpha, |\alpha| \leq m\} \end{aligned}$$

endowed with their natural semi-norms and norms. Recall that $\partial_{\mathbf{x}}^{\alpha}$ denotes the derivative with respect to the three variables x_1, x_2, x_3 .

We call these spaces *isotropic*, in opposition with the *anisotropic* spaces $\mathbf{M}_{\beta}^m(\mathcal{W})$ and $\mathbf{N}_{\beta}^n(\mathcal{W})$ which will be introduced in the next subsection.

We gather in one statement the results concerning the K and the J spaces. Here we set

$$(4.3) \quad \begin{aligned} \mathcal{W} &= (\mathcal{K} \cap \mathcal{B}(\mathbf{0}, 1)) \times (-1, 1) \\ \mathcal{W}_{\varepsilon} &= (\mathcal{K} \cap \mathcal{B}(\mathbf{0}, 1 + \varepsilon)) \times (-1 - \varepsilon, 1 + \varepsilon), \quad \varepsilon > 0. \end{aligned}$$

Theorem 4.2. *Let $\beta \in \mathbb{R}$ and $n \in \mathbb{N}$. Let $\mathbf{u} \in \mathbf{H}_{\text{loc}}^2(\overline{\mathcal{W}}_\varepsilon \setminus \mathbf{e})$ be a solution of problem (4.2) with $\mathcal{V} = \mathcal{W}_\varepsilon$.*

(i) *If $\mathbf{u} \in \mathbf{K}_\beta^1(\mathcal{W}_\varepsilon)$ and $\mathbf{f} \in \mathbf{K}_{\beta+2}^n(\mathcal{W}_\varepsilon)$ then $\mathbf{u} \in \mathbf{K}_\beta^{n+2}(\mathcal{W})$ and there exists a constant $C \geq 1$ independent of \mathbf{u} and n such that for any integer k , $0 \leq k \leq n+2$, we have*

$$(4.4) \quad \frac{1}{k!} \left(\sum_{|\alpha|=k} \|r^{\beta+|\alpha|} \partial_{\mathbf{x}}^\alpha \mathbf{u}\|_{0; \mathcal{W}}^2 \right)^{\frac{1}{2}} \leq C^{k+1} \left\{ \sum_{\ell=0}^{k-2} \frac{1}{\ell!} \left(\sum_{|\alpha|=\ell} \|r^{\beta+2+|\alpha|} \partial_{\mathbf{x}}^\alpha \mathbf{f}\|_{0; \mathcal{W}_\varepsilon}^2 \right)^{\frac{1}{2}} + \sum_{|\alpha| \leq 1} \|r^{\beta+|\alpha|} \partial_{\mathbf{x}}^\alpha \mathbf{u}\|_{0; \mathcal{W}_\varepsilon} \right\}.$$

(ii) *Let $m \geq 1$ be an integer. We assume that $\beta + m > -1$. Let $n \geq m-1$ be another integer. If $\mathbf{u} \in \mathbf{J}_\beta^m(\mathcal{W}_\varepsilon)$ and $\mathbf{f} \in \mathbf{J}_{\beta+2}^n(\mathcal{W}_\varepsilon)$, then $\mathbf{u} \in \mathbf{J}_\beta^{n+2}(\mathcal{W})$ and there exists a constant $C \geq 1$ independent of \mathbf{u} and n such that for any integer k , $m \leq k \leq n+2$, we have*

$$(4.5) \quad \frac{1}{k!} \left(\sum_{|\alpha|=k} \|r^{\beta+|\alpha|} \partial_{\mathbf{x}}^\alpha \mathbf{u}\|_{0; \mathcal{W}}^2 \right)^{\frac{1}{2}} \leq C^{k+1} \left\{ \sum_{\ell=m-1}^{k-2} \frac{1}{\ell!} \left(\sum_{|\alpha|=\ell} \|r^{\beta+2+|\alpha|} \partial_{\mathbf{x}}^\alpha \mathbf{f}\|_{0; \mathcal{W}_\varepsilon}^2 \right)^{\frac{1}{2}} + \sum_{|\alpha|=m} \|r^{\beta+|\alpha|} \partial_{\mathbf{x}}^\alpha \mathbf{u}\|_{0; \mathcal{W}_\varepsilon} \right\}.$$

Proof. Like in the case of Theorems 2.2 and 2.6, the proof relies on a locally finite dyadic covering of \mathcal{W} and \mathcal{W}_ε . The reference domains are now

$$\begin{aligned} \widehat{\mathcal{V}} &= \{\mathbf{x}_\perp \in \mathcal{K} : \frac{1}{4} < |\mathbf{x}_\perp| < 1\} \times (-\frac{1}{2}, \frac{1}{2}) \\ \widehat{\mathcal{V}}' &= \{\mathbf{x}_\perp \in \mathcal{K} : \frac{1}{4} - \varepsilon < |\mathbf{x}_\perp| < 1 + \varepsilon\} \times (-\frac{1}{2} - \varepsilon, \frac{1}{2} + \varepsilon) \end{aligned}$$

and for $\mu \in \mathbb{N}$ and $\nu \in \mathbb{Z}$:

$$\mathcal{V}_{\mu, \nu} = 2^{-\mu} (\widehat{\mathcal{V}} + (0, 0, \frac{\nu}{2})) \quad \text{and} \quad \mathcal{V}'_{\mu} = 2^{-\mu} (\widehat{\mathcal{V}}' + (0, 0, \frac{\nu}{2})).$$

We check immediately that

$$\mathcal{W} = \bigcup_{\mu \in \mathbb{N}} \bigcup_{|\nu| < 2^{\mu+1}} \mathcal{V}_{\mu, \nu} \quad \text{and} \quad \mathcal{W}_\varepsilon \supset \bigcup_{\mu \in \mathbb{N}} \bigcup_{|\nu| < 2^{\mu+1}} \mathcal{V}'_{\mu, \nu}.$$

and that these coverings are locally finite. An a priori estimate between $\mathcal{V}_{\mu, \nu}$ and $\mathcal{V}'_{\mu, \nu}$ is deduced from a reference a priori estimate between $\widehat{\mathcal{V}}$ and $\widehat{\mathcal{V}}'$ by the change of variables $\widehat{\mathbf{x}} \rightarrow \mathbf{x} = 2^{-\mu} (\widehat{\mathbf{x}} + (0, 0, \frac{\nu}{2}))$ that maps $\widehat{\mathcal{V}}$ onto $\mathcal{V}_{\mu, \nu}$ and $\widehat{\mathcal{V}}'$ onto $\mathcal{V}'_{\mu, \nu}$. Here we use the fact that the operators L , T and D are homogeneous with constant coefficients. Then the rest of the proof goes exactly as in the case of the plane sectors. \square

4.2. Tangential regularity along the edge (homogeneous norms). The result in the previous sections only rely on the ellipticity of the boundary value problem under consideration. Now we will require a stronger condition, which is a local Peetre-type a priori estimate in an edge neighborhood. From this condition we will derive analytic type estimates for all derivatives $\partial_{x_3}^j$ in the direction of the edge.

Assumption 4.3. Let $\beta \in \mathbb{R}$. Let \mathcal{W} and $\mathcal{W}' = \mathcal{W}_\varepsilon$ be the domains defined in (4.3) for some $\varepsilon > 0$. We assume that the following a priori estimate holds for problem (4.2) on $\mathcal{V} = \mathcal{W}'$: There is a constant C such that any

$$\mathbf{u} \in \mathbf{K}_\beta^2(\mathcal{W}),$$

solution of problem (4.2) with $\mathbf{f} \in \mathbf{K}_{\beta+2}^0(\mathcal{W}')$, satisfies:

$$(4.6) \quad \|\mathbf{u}\|_{\mathbf{K}_\beta^2(\mathcal{W})} \leq C \left(\|\mathbf{f}\|_{\mathbf{K}_{\beta+2}^0(\mathcal{W}')} + \|\mathbf{u}\|_{\mathbf{K}_{\beta+1}^1(\mathcal{W}')} \right).$$

Remark 4.4. (i) Assumption 4.3 is independent of ε (although the constant C depends on it), and more generally independent of the choice of the domains \mathcal{W} and \mathcal{W}' , if they satisfy the following conditions: There exists a ball with center on the edge \mathbf{e} contained in \mathcal{W} , and \mathcal{W}' contains $\overline{\mathcal{W}} \cap \mathcal{D}$.

(ii) The inequality (4.6) is a Peetre-type estimate, since $\mathbf{K}_\beta^2(\mathcal{W})$ is compactly embedded in $\mathbf{K}_{\beta+1}^1(\mathcal{W})$.

(iii) As a consequence of Theorem 4.2, it is equivalent to postulate the estimate

$$\|\mathbf{u}\|_{\mathbf{K}_\beta^1(\mathcal{W})} \leq C \left(\|\mathbf{f}\|_{\mathbf{K}_{\beta+2}^0(\mathcal{W}')} + \|\mathbf{u}\|_{\mathbf{K}_{\beta+1}^1(\mathcal{W}')} \right).$$

for all $\mathbf{u} \in \mathbf{K}_\beta^1(\mathcal{W}') \cap \mathbf{H}_{\text{loc}}^2(\overline{\mathcal{W}'} \setminus \mathbf{e})$

The first step for higher order estimates is the ρ -estimate for which we control the dependence of the constant C in (4.6) on the ‘‘distance’’ between \mathcal{W} and \mathcal{W}' .

Lemma 4.5. Under Assumption 4.3, let $R \in [0, \varepsilon)$ and $\rho \in (0, \varepsilon - R]$. Assume that $\mathbf{u} \in \mathbf{K}_\beta^2(\mathcal{W}_R)$ is a solution of problem (4.2) with $\mathbf{f} \in \mathbf{K}_{\beta+2}^0(\mathcal{V})$ for $\mathcal{V} = \mathcal{W}_{R+\rho}$. There exists a constant C independent of \mathbf{u} , R and ρ such that

$$(4.7) \quad \|\mathbf{u}\|_{\mathbf{K}_\beta^2(\mathcal{W}_R)} \leq C \left(\|\mathbf{f}\|_{\mathbf{K}_{\beta+2}^0(\mathcal{W}_{R+\rho})} + \rho^{-1} \|\mathbf{u}\|_{\mathbf{K}_{\beta+1}^1(\mathcal{W}_{R+\rho})} + \rho^{-2} \|\mathbf{u}\|_{\mathbf{K}_{\beta+2}^0(\mathcal{W}_{R+\rho})} \right).$$

Proof. We introduce a special family of cut-off functions χ_ρ . Let $\hat{\chi} \in \mathcal{C}^\infty(\mathbb{R})$ be such that $\hat{\chi} \equiv 1$ on $(-\infty, 0]$ and $\hat{\chi} \equiv 0$ on $[1, +\infty)$. Define $\hat{\chi}_\rho$ on \mathbb{R} by:

$$(4.8) \quad \hat{\chi}_\rho(t) = \hat{\chi} \left(\frac{|t| - 1 - R}{\rho} \right).$$

Thus $\hat{\chi}_\rho$ equals 1 in $[-1 - R, 1 + R]$ and 0 outside $(-1 - R - \rho, 1 + R + \rho)$. Then we set

$$(4.9) \quad \chi_\rho(\mathbf{x}) = \hat{\chi}_\rho(|\mathbf{x}_\perp|) \hat{\chi}_\rho(x_3).$$

Thus by construction, cf. (4.3)

$$\chi_\rho \equiv 1 \text{ on } \mathcal{W}_R \quad \text{and} \quad \chi_\rho \equiv 0 \text{ outside } \mathcal{W}_{R+\rho}.$$

We note the following important bound on the derivatives of χ_ρ

$$(4.10) \quad \exists D > 0, \quad \forall \rho > 0, \quad \forall \alpha, \quad |\alpha| \leq 2, \quad |\partial_{\mathbf{x}}^\alpha \chi_\rho| \leq D \rho^{-|\alpha|}.$$

Then in order to prove (4.7), it suffices to apply estimate (4.6) to $\chi_\rho \mathbf{u}$ and to check that the commutator $[L, \chi_\rho]$ applied to \mathbf{u} satisfies

$$(4.11) \quad \|[L, \chi_\rho] \mathbf{u}\|_{\mathbf{K}_{\beta+2}^0(\mathcal{W}_{R+\rho})} \leq C \left(\rho^{-1} \|\mathbf{u}\|_{\mathbf{K}_{\beta+1}^1(\mathcal{W}_{R+\rho})} + \rho^{-2} \|\mathbf{u}\|_{\mathbf{K}_{\beta+2}^0(\mathcal{W}_{R+\rho})} \right).$$

The latter estimate is an obvious consequence of (4.10) and the fact that

$$\|\partial_{\mathbf{x}}^\alpha \mathbf{u}\|_{\mathbf{K}_{\beta+2}^0(\mathcal{W}_{R+\rho})} \leq \|\mathbf{u}\|_{\mathbf{K}_{\beta+|\alpha|}^{2-|\alpha|}(\mathcal{W}_{R+\rho})}$$

for all α , $|\alpha| \leq 1$. \square

Corollary 4.6. *Under the assumptions of Lemma 4.5, if $\partial_{x_3} \mathbf{f} \in \mathbf{K}_{\beta+2}^0(\mathcal{W}_{R+\rho})$, then $\partial_{x_3} \mathbf{u} \in \mathbf{K}_{\beta}^2(\mathcal{W}_R)$ and there exists a constant $C \geq 1$ independent of R , ρ and \mathbf{u} such that*

$$(4.12) \quad \|\partial_{x_3} \mathbf{u}\|_{\mathbf{K}_{\beta}^2(\mathcal{W}_R)} \leq C \left(\|\partial_{x_3} \mathbf{f}\|_{\mathbf{K}_{\beta+2}^0(\mathcal{W}_{R+\rho})} + \rho^{-1} \|\mathbf{u}\|_{\mathbf{K}_{\beta}^2(\mathcal{W}_{R+\rho})} + \rho^{-2} \|\mathbf{u}\|_{\mathbf{K}_{\beta+1}^1(\mathcal{W}_{R+\rho})} \right).$$

Proof. For any $h < \rho/2$, we apply (4.7) in $\mathcal{W}_{R+\rho/2}$ to \mathbf{v}_h defined by

$$\mathbf{v}_h : \mathbf{x} \rightarrow h^{-1}(\mathbf{u}(\mathbf{x} + he_3) - \mathbf{u}(\mathbf{x})),$$

where $e_3 = (0, 0, 1)$. This yields

$$(4.13) \quad \begin{aligned} \|\mathbf{v}_h\|_{\mathbf{K}_{\beta}^2(\mathcal{W}_R)} &\leq 4C \left(\|L\mathbf{v}_h\|_{\mathbf{K}_{\beta+2}^0(\mathcal{W}_{R+\rho/2})} \right. \\ &\quad \left. + \rho^{-1} \|\mathbf{v}_h\|_{\mathbf{K}_{\beta+1}^1(\mathcal{W}_{R+\rho/2})} + \rho^{-2} \|\mathbf{v}_h\|_{\mathbf{K}_{\beta+2}^0(\mathcal{W}_{R+\rho/2})} \right), \end{aligned}$$

where C is the positive constant from Lemma 4.5. By noticing that

$$\mathbf{v}_h = h^{-1} \int_0^h \partial_{x_3} \mathbf{u}(\mathbf{x} + te_3) dt,$$

we check that for all $h < \rho/2$

$$\begin{aligned} \|L\mathbf{v}_h\|_{\mathbf{K}_{\beta+2}^0(\mathcal{W}_{R+\rho/2})} &\leq \|\partial_{x_3} L\mathbf{u}\|_{\mathbf{K}_{\beta+2}^0(\mathcal{W}_{R+\rho})}, \\ \|\mathbf{v}_h\|_{\mathbf{K}_{\beta+1}^1(\mathcal{W}_{R+\rho/2})} &\leq \|\partial_{x_3} \mathbf{u}\|_{\mathbf{K}_{\beta+1}^1(\mathcal{W}_{R+\rho})} \leq \|\mathbf{u}\|_{\mathbf{K}_{\beta}^2(\mathcal{W}_{R+\rho})}, \\ \|\mathbf{v}_h\|_{\mathbf{K}_{\beta+2}^0(\mathcal{W}_{R+\rho/2})} &\leq \|\partial_{x_3} \mathbf{u}\|_{\mathbf{K}_{\beta+2}^0(\mathcal{W}_{R+\rho})} \leq \|\mathbf{u}\|_{\mathbf{K}_{\beta+1}^1(\mathcal{W}_{R+\rho})}. \end{aligned}$$

This shows that the right-hand side of (4.13) is bounded uniformly in h . Therefore passing to the limit in (4.13), we find that $\partial_{x_3} \mathbf{u}$ belongs to $\mathbf{K}_{\beta}^2(\mathcal{W}_R)$ and that (4.12) holds. \square

Corollary 4.7. *Under Assumption 4.3, let $\mathbf{u} \in \mathbf{K}_{\beta}^2(\mathcal{W}_{\varepsilon})$ be a solution of (4.2). Let $R \in [0, \varepsilon/2]$ and $R' \geq \varepsilon/2$ with $R + R' \leq \varepsilon$. Then there exists a constant C independent of R , R' and \mathbf{u} such that for all $\ell \in \mathbb{N}$, we have*

$$(4.14) \quad \frac{1}{\ell!} \|\partial_{x_3}^\ell \mathbf{u}\|_{\mathbf{K}_{\beta}^2(\mathcal{W}_R)} \leq C^{\ell+1} \left\{ \sum_{j=0}^{\ell} \frac{1}{j!} \|\partial_{x_3}^j L\mathbf{u}\|_{\mathbf{K}_{\beta+2}^0(\mathcal{W}_{R+R'})} + \|\mathbf{u}\|_{\mathbf{K}_{\beta+1}^1(\mathcal{W}_{R+R'})} \right\}.$$

Proof. If $\ell = 0$, this is a consequence of estimate (4.6). For $\ell \geq 1$ the proof is divided into two steps. To keep notations simpler we take $R = 0$.

(i) We first prove by induction on ℓ that if $\rho \leq \varepsilon/(2\ell - 1)$, then

$$(4.15) \quad \|\partial_{x_3}^\ell \mathbf{u}\|_{\mathbf{K}_\beta^2(\mathcal{W})} \leq (2C)^\ell \left\{ \sum_{j=1}^{\ell} \rho^{-(\ell-j)} \|\partial_{x_3}^j L\mathbf{u}\|_{\mathbf{K}_{\beta+2}^0(\mathcal{W}_{(2\ell-j)\rho})} \right. \\ \left. + \rho^{-\ell} \|\mathbf{u}\|_{\mathbf{K}_\beta^2(\mathcal{W}_{(2\ell-1)\rho})} + \rho^{-\ell-1} \|\mathbf{u}\|_{\mathbf{K}_{\beta+1}^1(\mathcal{W}_{(2\ell-1)\rho})} \right\},$$

where $C \geq 1$ is the constant from Corollary 4.6.

- If $\ell = 1$, the estimate (4.15) is nothing else than (4.12). Hence it suffices to show that if (4.15) holds for ℓ , it holds for $\ell + 1$.
- For that purpose, we first apply (4.15) to \mathbf{v}_h defined as before by

$$\mathbf{v}_h : \mathbf{x} \rightarrow h^{-1}(\mathbf{u}(\mathbf{x} + he_3) - \mathbf{u}(\mathbf{x})),$$

and passing to the limit in h , we get

$$\|\partial_{x_3}^{\ell+1} \mathbf{u}\|_{\mathbf{K}_\beta^2(\mathcal{W})} \leq (2C)^\ell \left\{ \sum_{j=1}^{\ell} \rho^{-(\ell-j)} \|\partial_{x_3}^{j+1} L\mathbf{u}\|_{\mathbf{K}_{\beta+2}^0(\mathcal{W}_{(2\ell+1-j)\rho})} \right. \\ \left. + \rho^{-\ell} \|\partial_{x_3} \mathbf{u}\|_{\mathbf{K}_\beta^2(\mathcal{W}_{2\ell\rho})} + \rho^{-\ell-1} \|\partial_{x_3} \mathbf{u}\|_{\mathbf{K}_{\beta+1}^1(\mathcal{W}_{2\ell\rho})} \right\}.$$

For the second term of this right-hand side, we apply (4.12) to \mathbf{u} but between $\mathcal{W}_{2\ell\rho}$ and $\mathcal{W}_{(2\ell+1)\rho}$, while for the third term we use the fact that $\|\partial_{x_3} \mathbf{u}\|_{\mathbf{K}_{\beta+1}^1(\mathcal{W}_{2\ell\rho})} \leq \|\mathbf{u}\|_{\mathbf{K}_\beta^2(\mathcal{W}_{2\ell\rho})}$. This leads to

$$\|\partial_{x_3}^{\ell+1} \mathbf{u}\|_{\mathbf{K}_\beta^2(\mathcal{W})} \leq (2C)^\ell \sum_{j=1}^{\ell} \rho^{-(\ell-j)} \|\partial_{x_3}^{j+1} L\mathbf{u}\|_{\mathbf{K}_{\beta+2}^0(\mathcal{W}_{(2\ell+1-j)\rho})} \\ + (2C)^\ell C \rho^{-\ell} \left(\|\partial_{x_3} L\mathbf{u}\|_{\mathbf{K}_{\beta+2}^0(\mathcal{W}_{(2\ell+1)\rho})} + \rho^{-1} \|\mathbf{u}\|_{\mathbf{K}_\beta^2(\mathcal{W}_{(2\ell+1)\rho})} + \rho^{-2} \|\mathbf{u}\|_{\mathbf{K}_{\beta+1}^1(\mathcal{W}_{(2\ell+1)\rho})} \right) \\ + (2C)^\ell \rho^{-\ell-1} \|\mathbf{u}\|_{\mathbf{K}_\beta^2(\mathcal{W}_{2\ell\rho})}.$$

By the change of index $j' = j + 1$ in the sum on j , we finally get (since $(2C)^\ell \leq 2^\ell C^{\ell+1}$)

$$\|\partial_{x_3}^{\ell+1} \mathbf{u}\|_{\mathbf{K}_\beta^2(\mathcal{W})} \leq 2^\ell C^{\ell+1} \sum_{j=1}^{\ell+1} \rho^{-(\ell+1-j)} \|\partial_{x_3}^j L\mathbf{u}\|_{\mathbf{K}_{\beta+2}^0(\mathcal{W}_{(2(\ell+1)-j)\rho})} \\ + (2C)^\ell (C + 1) \rho^{-\ell-1} \|\mathbf{u}\|_{\mathbf{K}_\beta^2(\mathcal{W}_{(2\ell+1)\rho})} + (2C)^\ell C \rho^{-\ell-2} \|\mathbf{u}\|_{\mathbf{K}_{\beta+1}^1(\mathcal{W}_{(2\ell+1)\rho})}.$$

Since $C \geq 1$, $C + 1 \leq 2C$, and this proves that (4.15) holds for $\ell + 1$.

(ii) Now we choose ρ such that

$$\mathcal{W}_{(2\ell-1)\rho} \subset \mathcal{W}_{\varepsilon'} \quad \text{with} \quad \varepsilon' = \varepsilon/2.$$

This holds if we take

$$\rho = \frac{\gamma}{\ell} \quad \text{with} \quad \gamma = \min\left\{\frac{\varepsilon}{4}, 1\right\}.$$

Hence applying (4.15) with this choice of ρ , we obtain for all $\ell \geq 1$

$$(4.16) \quad \begin{aligned} \|\partial_{x_3}^\ell \mathbf{u}\|_{\mathbf{K}_\beta^2(\mathcal{W})} &\leq (2C)^\ell \left\{ \sum_{j=1}^{\ell} (\gamma^{-1})^{(\ell-j)} \ell^{\ell-j} \|\partial_{x_3}^j L\mathbf{u}\|_{\mathbf{K}_{\beta+2}^0(\mathcal{W}_{\varepsilon'})} \right. \\ &\quad \left. + (\gamma^{-1})^\ell \ell^\ell \|\mathbf{u}\|_{\mathbf{K}_\beta^2(\mathcal{W}_{\varepsilon'})} + (\gamma^{-1})^{\ell+1} \ell^{\ell+1} \|\mathbf{u}\|_{\mathbf{K}_{\beta+1}^1(\mathcal{W}_{\varepsilon'})} \right\}. \end{aligned}$$

Since $\gamma \leq 1$, $(\gamma^{-1})^{(\ell-j)} \leq (\gamma^{-1})^\ell$. Moreover by Stirling's formula, one has

$$\ell^\ell \leq S^\ell \ell!$$

for some $S > 1$. We find

$$\frac{\ell^{\ell-j} j!}{\ell!} = \frac{\ell^\ell j!}{\ell! \ell^j} \leq \frac{S^\ell j!}{\ell^j} \leq S^\ell,$$

since $j! \leq j^j \leq \ell^j$. Inserting this into (4.16) gives, with $C_1 = 2C\gamma^{-1}S$,

$$\|\partial_{x_3}^\ell \mathbf{u}\|_{\mathbf{K}_\beta^2(\mathcal{W})} \leq C_1^\ell \left\{ \sum_{j=1}^{\ell} \frac{\ell!}{j!} \|\partial_{x_3}^j L\mathbf{u}\|_{\mathbf{K}_{\beta+2}^0(\mathcal{W}_{\varepsilon'})} + \ell! \|\mathbf{u}\|_{\mathbf{K}_\beta^2(\mathcal{W}_{\varepsilon'})} + \gamma^{-1} \ell! \|\mathbf{u}\|_{\mathbf{K}_{\beta+1}^1(\mathcal{W}_{\varepsilon'})} \right\}.$$

Using the trivial inequality $\ell \leq 2^\ell$, we arrive at

$$\|\partial_{x_3}^\ell \mathbf{u}\|_{\mathbf{K}_\beta^2(\mathcal{W})} \leq C_2^\ell \left\{ \sum_{j=1}^{\ell} \frac{\ell!}{j!} \|\partial_{x_3}^j L\mathbf{u}\|_{\mathbf{K}_{\beta+2}^0(\mathcal{W}_{\varepsilon'})} + \ell! \|\mathbf{u}\|_{\mathbf{K}_\beta^2(\mathcal{W}_{\varepsilon'})} + \ell! \|\mathbf{u}\|_{\mathbf{K}_{\beta+1}^1(\mathcal{W}_{\varepsilon'})} \right\},$$

which, combined with (4.7) between $\mathcal{W}_{\varepsilon'}$ and \mathcal{W}_ε , yields the requested estimate. \square

4.3. Anisotropic estimates in dihedral domains (homogeneous norms). We are now ready to prove the main results of this section, namely the weighted anisotropic regularity of solutions of our local boundary value problem (4.2). For this we introduce the following new class of weighted spaces:

Definition 4.8. Let β be a real number and let $m \geq 0$ be an integer.

Let \mathcal{W} be a subdomain of the dihedral domain \mathcal{D} . We recall that $r = |\mathbf{x}_\perp|$ denotes the distance to the edge $\mathbf{e} \equiv \{\mathbf{x}_\perp = 0\}$. The *anisotropic weighted space with homogeneous norm* $M_\beta^m(\mathcal{W})$ is defined by

$$(4.17) \quad M_\beta^m(\mathcal{W}) = \left\{ u \in L_{\text{loc}}^2(\mathcal{W}) : r^{\beta+|\alpha_\perp|} \partial_{\mathbf{x}}^\alpha u \in L^2(\mathcal{W}), \quad \forall \alpha, |\alpha| \leq m \right\}$$

where for $\alpha = (\alpha_1, \alpha_2, \alpha_3)$, $\alpha_\perp = (\alpha_1, \alpha_2)$ is the component of α in the direction perpendicular to the edge \mathbf{e} . The norm of this space is defined as

$$(4.18) \quad \|u\|_{M_\beta^m(\mathcal{W})}^2 = \sum_{k=0}^m \sum_{|\alpha|=k} \|r^{\beta+|\alpha_\perp|} \partial_{\mathbf{x}}^\alpha u\|_{0;\mathcal{W}}^2.$$

Theorem 4.9. *Under Assumption 4.3, let $\mathbf{u} \in \mathbf{K}_\beta^1(\mathcal{W}_\varepsilon)$ be a solution of problem (4.2). If $\mathbf{f} \in \mathbf{M}_{\beta+2}^n(\mathcal{W}_\varepsilon)$, then $\mathbf{u} \in \mathbf{M}_\beta^n(\mathcal{W})$, and there exists a positive constant C independent of \mathbf{u} and m such that for all integer k , $0 \leq k \leq n$ we have*

$$(4.19) \quad \frac{1}{k!} \left(\sum_{|\alpha|=k} \|r^{\beta+|\alpha_\perp|} \partial_{\mathbf{x}}^\alpha \mathbf{u}\|_{0; \mathcal{W}}^2 \right)^{\frac{1}{2}} \leq C^{k+1} \left\{ \sum_{\ell=0}^k \frac{1}{\ell!} \left(\sum_{|\alpha|=\ell} \|r^{\beta+2+|\alpha_\perp|} \partial_{\mathbf{x}}^\alpha \mathbf{f}\|_{0; \mathcal{W}_\varepsilon}^2 \right)^{\frac{1}{2}} + \|\mathbf{u}\|_{\mathbf{K}_{\beta+1}^1(\mathcal{W}_\varepsilon)} \right\}.$$

Proof. (i) We first apply the isotropic estimate (4.4) between \mathcal{W} and $\mathcal{W}_{\varepsilon/4}$, and combine with (4.6) between $\mathcal{W}_{\varepsilon/4}$ and $\mathcal{W}_{\varepsilon/2}$ (cf. Remark 4.4 (i)). This yields the estimate for all k , $0 \leq k \leq n$, and with $\varepsilon' = \varepsilon/2$

$$\frac{1}{k!} \left(\sum_{|\alpha|=k} \|r^{\beta+|\alpha|} \partial_{\mathbf{x}}^\alpha \mathbf{u}\|_{0; \mathcal{W}}^2 \right)^{\frac{1}{2}} \leq C^{k+1} \left\{ \sum_{\ell=0}^{k-2} \frac{1}{\ell!} \left(\sum_{|\alpha|=\ell} \|r^{\beta+2+|\alpha|} \partial_{\mathbf{x}}^\alpha \mathbf{f}\|_{0; \mathcal{W}_{\varepsilon'}}^2 \right)^{\frac{1}{2}} + \|r^{\beta+2} \mathbf{f}\|_{0; \mathcal{W}_{\varepsilon'}} + \|\mathbf{u}\|_{\mathbf{K}_{\beta+1}^1(\mathcal{W}_{\varepsilon'})} \right\}.$$

In order to absorb the term $\|r^{\beta+2} \mathbf{f}\|_{0; \mathcal{W}_{\varepsilon'}}$ in the sum on the right-hand side (including when $k = 0$ or 1), we write the previous inequality in the slightly weaker form

$$\frac{1}{k!} \left(\sum_{|\alpha|=k} \|r^{\beta+|\alpha|} \partial_{\mathbf{x}}^\alpha \mathbf{u}\|_{0; \mathcal{W}}^2 \right)^{\frac{1}{2}} \leq C_1^{k+1} \left\{ \sum_{\ell=0}^k \frac{1}{\ell!} \left(\sum_{|\alpha|=\ell} \|r^{\beta+2+|\alpha|} \partial_{\mathbf{x}}^\alpha \mathbf{f}\|_{0; \mathcal{W}_{\varepsilon'}}^2 \right)^{\frac{1}{2}} + \|\mathbf{u}\|_{\mathbf{K}_{\beta+1}^1(\mathcal{W}_{\varepsilon'})} \right\}.$$

We reduce the left-hand side to any $\alpha = (\alpha_\perp, 0)$ of length $q \geq 0$, and bound $r^{\beta+2+|\alpha|}$ by $r^{\beta+2+|\alpha_\perp|}$ in the right-hand side (recall that r is bounded in \mathcal{W}_ε) to obtain for all q , $0 \leq q \leq n$

$$(4.20) \quad \frac{1}{q!} \left(\sum_{|\alpha_\perp|=q} \|r^{\beta+|\alpha_\perp|} \partial_{\mathbf{x}_\perp}^{\alpha_\perp} \mathbf{u}\|_{0; \mathcal{W}}^2 \right)^{\frac{1}{2}} \leq C_2^{q+1} \left\{ \sum_{\ell=0}^q \frac{1}{\ell!} \left(\sum_{|\alpha|=\ell} \|r^{\beta+2+|\alpha_\perp|} \partial_{\mathbf{x}}^\alpha \mathbf{f}\|_{0; \mathcal{W}_{\varepsilon'}}^2 \right)^{\frac{1}{2}} + \|\mathbf{u}\|_{\mathbf{K}_{\beta+1}^1(\mathcal{W}_{\varepsilon'})} \right\}.$$

(ii) We now prove that for all $\mu = 0, \dots, n$ and for all $q = 0, \dots, n - \mu$ one has the following estimates with $k := q + \mu$ and a constant C_3 independent of \mathbf{u} , q and μ

$$(4.21) \quad \frac{1}{k!} \left(\sum_{|\alpha_\perp|=q} \|r^{\beta+|\alpha_\perp|} \partial_{\mathbf{x}_\perp}^{\alpha_\perp} \partial_{x_3}^\mu \mathbf{u}\|_{0; \mathcal{W}}^2 \right)^{\frac{1}{2}} \leq C_3^{k+1} \left\{ \sum_{\ell=0}^k \frac{1}{\ell!} \left(\sum_{|\alpha|=\ell} \|r^{\beta+2+|\alpha_\perp|} \partial_{\mathbf{x}}^\alpha \mathbf{f}\|_{0; \mathcal{W}_\varepsilon}^2 \right)^{\frac{1}{2}} + \|\mathbf{u}\|_{\mathbf{K}_{\beta+1}^1(\mathcal{W}_\varepsilon)} \right\}.$$

1. If $\mu = 0$, this estimate is a consequence of (4.20) since $\mathcal{W}_{\varepsilon'} \subset \mathcal{W}_\varepsilon$.

2. If $\mu > 0$ (or equivalently $q < k$), we apply (4.20) to $\partial_{x_3}^\mu \mathbf{u}$ to obtain

$$(4.22) \quad \frac{1}{q!} \left(\sum_{|\alpha_\perp|=q} \|r^{\beta+|\alpha_\perp|} \partial_{\mathbf{x}_\perp}^{\alpha_\perp} \partial_{x_3}^\mu \mathbf{u}\|_{0; \mathcal{W}}^2 \right)^{\frac{1}{2}} \leq C_2^{q+1} \left\{ \sum_{\ell=0}^q \frac{1}{\ell!} \left(\sum_{|\alpha|= \ell} \|r^{\beta+2+|\alpha_\perp|} \partial_{\mathbf{x}}^\alpha \partial_{x_3}^\mu \mathbf{f}\|_{0; \mathcal{W}_{\varepsilon'}}^2 \right)^{\frac{1}{2}} + \|\partial_{x_3}^\mu \mathbf{u}\|_{\mathbf{K}_{\beta+1}^1(\mathcal{W}_{\varepsilon'})} \right\}.$$

The last term of this right-hand side is now estimated with the help of Corollary 4.7. Using that

$$\|\partial_{x_3}^\mu \mathbf{u}\|_{\mathbf{K}_{\beta+1}^1(\mathcal{W}_{\varepsilon'})} \leq \|\partial_{x_3}^{\mu-1} \mathbf{u}\|_{\mathbf{K}_{\beta}^2(\mathcal{W}_{\varepsilon'})},$$

and applying (4.14) between $\mathcal{W}_{\varepsilon'}$ and \mathcal{W}_ε with $\ell = \mu - 1$, we obtain

$$\|\partial_{x_3}^\mu \mathbf{u}\|_{\mathbf{K}_{\beta+1}^1(\mathcal{W}_{\varepsilon'})} \leq C_4^\mu (\mu - 1)! \left(\sum_{j=0}^{\mu-1} \frac{1}{j!} \|\partial_{x_3}^j \mathbf{f}\|_{\mathbf{K}_{\beta+2}^0(\mathcal{W}_\varepsilon)} + \|\mathbf{u}\|_{\mathbf{K}_{\beta+1}^1(\mathcal{W}_\varepsilon)} \right).$$

Using this estimate in (4.22) we obtain that

$$\begin{aligned} \frac{1}{q!} \left(\sum_{|\alpha_\perp|=q} \|r^{\beta+|\alpha_\perp|} \partial_{\mathbf{x}_\perp}^{\alpha_\perp} \partial_{x_3}^\mu \mathbf{u}\|_{0; \mathcal{W}}^2 \right)^{\frac{1}{2}} &\leq C_2^{q+1} \sum_{\ell=0}^q \frac{1}{\ell!} \left(\sum_{|\alpha|= \ell} \|r^{\beta+2+|\alpha_\perp|} \partial_{x_3}^\mu \partial_{\mathbf{x}}^\alpha \mathbf{f}\|_{0; \mathcal{W}_\varepsilon}^2 \right)^{\frac{1}{2}} \\ &+ C_2^{q+1} C_4^\mu (\mu - 1)! \left(\sum_{j=0}^{\mu-1} \frac{1}{j!} \|\partial_{x_3}^j \mathbf{f}\|_{\mathbf{K}_{\beta+2}^0(\mathcal{W}_\varepsilon)} + \|\mathbf{u}\|_{\mathbf{K}_{\beta+1}^1(\mathcal{W}_\varepsilon)} \right). \end{aligned}$$

Multiplying this estimate by $q!(k!)^{-1}$, we find (since $q!(\mu - 1)!(k!)^{-1} \leq 1$)

$$\begin{aligned} \frac{1}{k!} \left(\sum_{|\alpha_\perp|=q} \|r^{\beta+|\alpha_\perp|} \partial_{\mathbf{x}_\perp}^{\alpha_\perp} \partial_{x_3}^\mu \mathbf{u}\|_{0; \mathcal{W}}^2 \right)^{\frac{1}{2}} &\leq C_2^{q+1} \sum_{\ell=0}^q \frac{q!}{\ell! k!} \left(\sum_{|\alpha|= \ell} \|r^{\beta+2+|\alpha_\perp|} \partial_{x_3}^\mu \partial_{\mathbf{x}}^\alpha \mathbf{f}\|_{0; \mathcal{W}_\varepsilon}^2 \right)^{\frac{1}{2}} \\ &+ C_2^{q+1} C_4^\mu \left(\sum_{j=0}^{\mu-1} \frac{1}{j!} \|\partial_{x_3}^j \mathbf{f}\|_{\mathbf{K}_{\beta+2}^0(\mathcal{W}_\varepsilon)} + \|\mathbf{u}\|_{\mathbf{K}_{\beta+1}^1(\mathcal{W}_\varepsilon)} \right). \end{aligned}$$

For the first term of this right-hand side we finally notice that $\partial_{x_3}^\mu \partial^\alpha = \partial^{\alpha+(0,0,\mu)}$ and that $|\alpha + (0, 0, \mu)| = \ell + \mu$. Hence we have to check that

$$\frac{q!}{\ell! k!} \leq \frac{1}{(\ell + \mu)!},$$

which is equivalent to

$$\frac{(\ell + \mu)! q!}{\ell! k!} \leq 1,$$

and holds since $\ell + \mu \leq k$ and $q \leq k$.

Altogether we have proved that (4.21) holds for all $\mu \in \mathbb{N}$ such that $q + \mu = k$.

(iii) Summing the square of this estimate (4.21) on $q = 0, \dots, k$ and $\mu = 0, \dots, k - q$, we arrive at

$$\frac{1}{k!} \left(\sum_{|\alpha|=k} \|r^{\beta+|\alpha_\perp|} \partial^\alpha \mathbf{u}\|_{0; \mathcal{W}}^2 \right)^{\frac{1}{2}} \leq k^2 C_3^{k+1} \left(\sum_{\ell=0}^k \frac{1}{\ell!} \left(\sum_{|\alpha|=\ell} \|r^{\beta+2+|\alpha_\perp|} \partial^\alpha \mathbf{f}\|_{0; \mathcal{W}_\varepsilon}^2 \right)^{\frac{1}{2}} + \|\mathbf{u}\|_{\mathbf{K}_{\beta+1}^1(\mathcal{W}_\varepsilon)} \right).$$

This proves the theorem. \square

4.4. Anisotropic estimates in dihedral domains (non-homogeneous norms). In this last part of section 4 devoted to local estimates in dihedral domains, we investigate the situation where the a priori estimate holds in the J-weighted scale instead the K scale. We set:

Assumption 4.10. Let $m \geq 1$ be an integer. Let $\beta \in \mathbb{R}$ such that $\beta + m > -1$. We assume that the following a priori estimate holds for problem (4.2): There is a constant C such that any

$$\mathbf{u} \in \mathbf{J}_\beta^{m+1}(\mathcal{W}),$$

solution of problem (4.2) in $\mathcal{V} = \mathcal{W}'$ with $\mathbf{f} \in \mathbf{J}_{\beta+2}^{m-1}(\mathcal{W}')$, satisfies:

$$(4.23) \quad \|\mathbf{u}\|_{\mathbf{J}_\beta^{m+1}(\mathcal{W})} \leq C \left(\|\mathbf{f}\|_{\mathbf{J}_{\beta+2}^{m-1}(\mathcal{W}')} + \|\mathbf{u}\|_{\mathbf{J}_{\beta+1}^m(\mathcal{W}')} \right).$$

Remark 4.11. Using the analogue of Proposition 2.4 for dihedral domains, i.e., that the norm in the space $\mathbf{J}_\beta^m(\mathcal{W})$ is equivalent to $\left(\sum_{|\alpha| \leq m} \|r^{\max\{\beta+|\alpha|, \sigma\}} \partial_\mathbf{x}^\alpha u\|_{0; \mathcal{W}}^2 \right)^{\frac{1}{2}}$ for all $\sigma \in (-1, \beta + m]$, we can take $\sigma = 0$ for $\mathbf{J}_\beta^{m+1}(\mathcal{W})$ when $\beta + m > -1$, i.e., $\beta + m + 1 > 0$: We obtain that in the situation of Assumption 4.10 the norm in the space $\mathbf{J}_\beta^{m+1}(\mathcal{W})$ is equivalent to

$$(4.24) \quad \left(\sum_{|\alpha| \leq m+1} \|r^{\max\{\beta+|\alpha|, 0\}} \partial_\mathbf{x}^\alpha u\|_{0; \mathcal{W}}^2 \right)^{\frac{1}{2}}.$$

The non-homogeneous anisotropic weighted spaces are defined as follows on the model of the homogeneous ones (Definition 4.8):

Definition 4.12. Let $m \geq 1$ be an integer. Let $\beta \in \mathbb{R}$ such that $\beta + m > -1$.

Let \mathcal{W} be a subdomain of the dihedral domain \mathcal{D} and $n > m$ be an integer. The *anisotropic weighted space with non-homogeneous norm* $\mathbf{N}_\beta^n(\mathcal{W})$ is defined by

$$(4.25) \quad \mathbf{N}_\beta^n(\mathcal{W}) = \{u \in \mathbf{L}_{\text{loc}}^2(\mathcal{W}) : r^{\max\{\beta+|\alpha_\perp|, 0\}} \partial_\mathbf{x}^\alpha u \in \mathbf{L}^2(\mathcal{W}), \quad \forall \alpha, |\alpha| \leq n\}$$

endowed with its natural norm.

Our aim is to prove the “non-homogeneous” analogue of Theorem 4.9:

Theorem 4.13. *Under Assumption 4.10, let $\mathbf{u} \in \mathbf{J}_\beta^m(\mathcal{W}_\varepsilon)$ be a solution of problem (4.2). If $\mathbf{f} \in \mathbf{N}_{\beta+2}^n(\mathcal{W}_\varepsilon)$ for an integer $n > m$, then $\mathbf{u} \in \mathbf{N}_\beta^n(\mathcal{W})$, and there exists a positive constant*

C independent of \mathbf{u} and n such that for all integer k , $0 \leq k \leq n$ we have

$$(4.26) \quad \frac{1}{k!} \left(\sum_{|\alpha|=k} \|r^{\max\{\beta+|\alpha_\perp|, 0\}} \partial_{\mathbf{x}}^\alpha \mathbf{u}\|_{0; \mathcal{W}}^2 \right)^{\frac{1}{2}} \leq C^{k+1} \left\{ \sum_{\ell=0}^k \frac{1}{\ell!} \left(\sum_{|\alpha|=\ell} \|r^{\max\{\beta+2+|\alpha_\perp|, 0\}} \partial_{\mathbf{x}}^\alpha \mathbf{f}\|_{0; \mathcal{W}_\varepsilon}^2 \right)^{\frac{1}{2}} + \|\mathbf{u}\|_{\mathbf{J}_{\beta+1}^m(\mathcal{W}_\varepsilon)} \right\}.$$

Proof. We review the sequence of steps leading to Theorem 4.9 and adapt them to non-homogeneous norms.

(i) Applying (4.23) to $\chi_\rho \mathbf{u}$ with the function χ_ρ introduced in (4.9), we obtain, – compare with (4.7),

$$\|\mathbf{u}\|_{\mathbf{J}_\beta^{m+1}(\mathcal{W}_R)} \leq C \left(\|\mathbf{f}\|_{\mathbf{J}_{\beta+2}^{m-1}(\mathcal{W}_{R+\rho})} + \sum_{\lambda=0}^m \rho^{-1-\lambda} \|\mathbf{u}\|_{\mathbf{J}_{\beta+1+\lambda}^{m-\lambda}(\mathcal{W}_{R+\rho})} \right).$$

(ii) By the differential quotients technique we deduce, – compare with (4.12),

$$\|\partial_{x_3} \mathbf{u}\|_{\mathbf{J}_\beta^{m+1}(\mathcal{W}_R)} \leq C \left(\|\partial_{x_3} \mathbf{f}\|_{\mathbf{J}_{\beta+2}^{m-1}(\mathcal{W}_{R+\rho})} + \sum_{\lambda=0}^m \rho^{-1-\lambda} \|\mathbf{u}\|_{\mathbf{J}_{\beta+\lambda}^{m+1-\lambda}(\mathcal{W}_{R+\rho})} \right),$$

since $\|\partial_{x_3} \mathbf{u}\|_{\mathbf{J}_{\beta+1+\lambda}^{m-\lambda}(\mathcal{W}_{R+\rho})}$ is bounded by $\|\mathbf{u}\|_{\mathbf{J}_{\beta+\lambda}^{m+1-\lambda}(\mathcal{W}_{R+\rho})}$.

(iii) Iterating this on the model of (4.15) we find for $\ell \geq 1$

$$\|\partial_{x_3}^\ell \mathbf{u}\|_{\mathbf{J}_\beta^{m+1}(\mathcal{W})} \leq (2C)^\ell \left\{ \sum_{j=1}^{\ell} \rho^{-(\ell-j)} \|\partial_{x_3}^j L\mathbf{u}\|_{\mathbf{J}_{\beta+2}^{m-1}(\mathcal{W}_{(2\ell-j)\rho})} + \sum_{\lambda=0}^m \rho^{-\ell-\lambda} \|\mathbf{u}\|_{\mathbf{J}_{\beta+\lambda}^{m+1-\lambda}(\mathcal{W}_{(2\ell-1)\rho})} \right\},$$

leading to the analytic type estimate, – compare with (4.14),

$$(4.27) \quad \frac{1}{\ell!} \|\partial_{x_3}^\ell \mathbf{u}\|_{\mathbf{J}_\beta^{m+1}(\mathcal{W}_R)} \leq C^{\ell+1} \left\{ \sum_{j=0}^{\ell} \frac{1}{j!} \|\partial_{x_3}^j L\mathbf{u}\|_{\mathbf{J}_{\beta+2}^{m-1}(\mathcal{W}_{R+R'})} + \|\mathbf{u}\|_{\mathbf{J}_{\beta+1}^m(\mathcal{W}_{R+R'})} \right\}.$$

(iv) To prove (4.26), we start with the proof of, – compare with (4.20),

$$(4.28) \quad \frac{1}{q!} \left(\sum_{|\alpha_\perp|=q} \|r^{\max\{\beta+|\alpha_\perp|, 0\}} \partial_{\mathbf{x}_\perp}^{\alpha_\perp} \mathbf{u}\|_{0; \mathcal{W}}^2 \right)^{\frac{1}{2}} \leq C_2^{q+1} \left\{ \sum_{\ell=0}^q \frac{1}{\ell!} \left(\sum_{|\alpha|=\ell} \|r^{\max\{\beta+2+|\alpha_\perp|, 0\}} \partial_{\mathbf{x}}^\alpha \mathbf{f}\|_{0; \mathcal{W}_{\varepsilon'}}^2 \right)^{\frac{1}{2}} + \|\mathbf{u}\|_{\mathbf{J}_{\beta+1}^m(\mathcal{W}_{\varepsilon'})} \right\}.$$

• For $q = 0, \dots, m$, we rely on the estimate (4.23) combined with the use of the norm (4.24) for $\mathbf{J}_\beta^{m+1}(\mathcal{W})$: If we restrict the left-hand side to the derivatives of the form $\partial_{\mathbf{x}_\perp}^{\alpha_\perp}$ and replace the weight $r^{\max\{\beta+2+|\alpha|, 0\}}$ by $r^{\max\{\beta+2+|\alpha_\perp|, 0\}}$ in the right-hand side, we obtain (4.28).

- For $q \geq m + 1$, we combine the estimate (4.23) with the isotropic non-homogeneous estimate (4.5) and making the same restriction to $\partial_{\mathbf{x}_\perp}^{\alpha_\perp}$ in the left-hand side and the same change of weights in the right-hand side.

(v) We continue with the proof that for all $\mu = 0, \dots, n$ and for all $q = 0, \dots, n - \mu$ one has the following estimates with $k := q + \mu$ and a constant C_3 independent of \mathbf{u} , q and μ

$$(4.29) \quad \frac{1}{k!} \left(\sum_{|\alpha_\perp|=q} \|r^{\max\{\beta+|\alpha_\perp|, 0\}} \partial_{\mathbf{x}_\perp}^{\alpha_\perp} \partial_{x_3}^\mu \mathbf{u}\|_{0; \mathcal{W}}^2 \right)^{\frac{1}{2}} \leq C_3^{k+1} \left\{ \sum_{\ell=0}^k \frac{1}{\ell!} \left(\sum_{|\alpha|=\ell} \|r^{\max\{\beta+2+|\alpha_\perp|, 0\}} \partial_{\mathbf{x}}^\alpha \mathbf{f}\|_{0; \mathcal{W}_\varepsilon}^2 \right)^{\frac{1}{2}} + \|\mathbf{u}\|_{\mathbf{J}_{\beta+1}^m(\mathcal{W}_\varepsilon)} \right\}.$$

1. If $\mu = 0$, this estimate is a consequence of (4.28) since $\mathcal{W}_{\varepsilon'} \subset \mathcal{W}_\varepsilon$.
2. If $\mu > 0$ (or equivalently $q < k$), we apply (4.28) to $\partial_{x_3}^\mu \mathbf{u}$ to obtain

$$(4.30) \quad \frac{1}{q!} \left(\sum_{|\alpha_\perp|=q} \|r^{\max\{\beta+|\alpha_\perp|, 0\}} \partial_{\mathbf{x}_\perp}^{\alpha_\perp} \partial_{x_3}^\mu \mathbf{u}\|_{0; \mathcal{W}}^2 \right)^{\frac{1}{2}} \leq C_2^{q+1} \left\{ \sum_{\ell=0}^q \frac{1}{\ell!} \left(\sum_{|\alpha|=\ell} \|r^{\max\{\beta+2+|\alpha_\perp|, 0\}} \partial_{\mathbf{x}}^\alpha \partial_{x_3}^\mu \mathbf{f}\|_{0; \mathcal{W}_{\varepsilon'}}^2 \right)^{\frac{1}{2}} + \|\partial_{x_3}^\mu \mathbf{u}\|_{\mathbf{J}_{\beta+1}^m(\mathcal{W}_{\varepsilon'})} \right\}.$$

The last term of this right-hand side is now estimated with the help of (4.27) with $\ell = \mu - 1$

$$\|\partial_{x_3}^\mu \mathbf{u}\|_{\mathbf{J}_{\beta+1}^m(\mathcal{W}_{\varepsilon'})} \leq \|\partial_{x_3}^{\mu-1} \mathbf{u}\|_{\mathbf{J}_\beta^{m+1}(\mathcal{W}_{\varepsilon'})} \leq C_4^\mu (\mu - 1)! \left(\sum_{j=0}^{\mu-1} \frac{1}{j!} \|\partial_{x_3}^j \mathbf{f}\|_{\mathbf{J}_{\beta+2}^{m-1}(\mathcal{W}_\varepsilon)} + \|\mathbf{u}\|_{\mathbf{J}_{\beta+1}^m(\mathcal{W}_\varepsilon)} \right).$$

Using this estimate in (4.30) we obtain that

$$\begin{aligned} & \frac{1}{q!} \left(\sum_{|\alpha_\perp|=q} \|r^{\max\{\beta+|\alpha_\perp|, 0\}} \partial_{\mathbf{x}_\perp}^{\alpha_\perp} \partial_{x_3}^\mu \mathbf{u}\|_{0; \mathcal{W}}^2 \right)^{\frac{1}{2}} \leq \\ & C_2^{q+1} \sum_{\ell=0}^q \frac{1}{\ell!} \left(\sum_{|\alpha|=\ell} \|r^{\max\{\beta+2+|\alpha_\perp|, 0\}} \partial_{\mathbf{x}}^\alpha \partial_{x_3}^\mu \mathbf{f}\|_{0; \mathcal{W}_\varepsilon}^2 \right)^{\frac{1}{2}} \\ & + C_2^{q+1} C_4^\mu (\mu - 1)! \left(\sum_{j=0}^{\mu-1} \frac{1}{j!} \|\partial_{x_3}^j \mathbf{f}\|_{\mathbf{J}_{\beta+2}^{m-1}(\mathcal{W}_\varepsilon)} + \|\mathbf{u}\|_{\mathbf{J}_{\beta+1}^m(\mathcal{W}_\varepsilon)} \right). \end{aligned}$$

We note that the norm in the space $\mathbf{J}_{\beta+2}^{m-1}(\mathcal{W}_\varepsilon)$ is equivalent to (cf. (4.24))

$$\left(\sum_{|\alpha| \leq m-1} \|r^{\max\{\beta+2+|\alpha|, 0\}} \partial_{\mathbf{x}}^\alpha u\|_{0; \mathcal{W}}^2 \right)^{\frac{1}{2}}.$$

Thus dividing the latter estimate by $\mu!$ and recalling that $k = q + \mu$ we deduce

$$\begin{aligned} & \frac{1}{k!} \left(\sum_{|\alpha_\perp|=q} \|r^{\max\{\beta+|\alpha_\perp|, 0\}} \partial_{\mathbf{x}_\perp}^{\alpha_\perp} \partial_{x_3}^\mu \mathbf{u}\|_{0; \mathcal{W}}^2 \right)^{\frac{1}{2}} \leq \\ & C_5^{k+1} \sum_{\ell=0}^q \frac{1}{\ell! \mu!} \left(\sum_{|\alpha|=\ell} \|r^{\max\{\beta+2+|\alpha_\perp|, 0\}} \partial_{\mathbf{x}}^\alpha \partial_{x_3}^\mu \mathbf{f}\|_{0; \mathcal{W}_\varepsilon}^2 \right)^{\frac{1}{2}} \\ & + C_5^{k+1} \left(\sum_{j=0}^{\mu-1} \frac{1}{j!} \sum_{|\alpha| \leq m-1} \|r^{\max\{\beta+2+|\alpha|, 0\}} \partial_{\mathbf{x}}^\alpha \partial_{x_3}^j \mathbf{f}\|_{0; \mathcal{W}_\varepsilon} + \|\mathbf{u}\|_{\mathbf{J}_{\beta+1}^m(\mathcal{W}_\varepsilon)} \right). \end{aligned}$$

From this we deduce (4.29). The final way to (4.26) is very similar to the conclusion of the proof of Theorem 4.9. This ends the proof of Theorem 4.13. \square

Remark 4.14. We note some similarities between our estimates and those obtained in [16] for the Laplace operator. Our argument based on the dyadic partition technique clearly improves the structure of the whole proof.

5. ANALYTIC ANISOTROPIC WEIGHTED REGULARITY SHIFT IN POLYHEDRA

5.1. Edge and corner neighborhoods. Let Ω be a polyhedron in \mathbb{R}^3 , that is a domain whose boundary is a finite union of plane domains (the faces $\Gamma_{\mathbf{s}}$, $\mathbf{s} \in \mathcal{S}$). The faces are polygonal, the segments forming their boundaries are the edges \mathbf{e} of Ω , and the ends of the edges are the corners \mathbf{c} of Ω . We denote the set of edges by \mathcal{E} and the set of corners by \mathcal{C} . Edge openings may be equal to 2π , allowing domains with crack surfaces.

In order to prove global regularity results in suitable weighted Sobolev spaces, we introduce corner, edge and edge-vertex neighborhoods of Ω . For a fixed corner $\mathbf{c} \in \mathcal{C}$, we denote by $\mathcal{E}_{\mathbf{c}}$ the set of edges that have \mathbf{c} as extremities. Similarly for a fixed edge $\mathbf{e} \in \mathcal{E}$, we denote by $\mathcal{C}_{\mathbf{e}}$ the set of corners that are extremities of \mathbf{e} . Now we introduce the following distances:

$$(5.1) \quad r_{\mathbf{c}}(\mathbf{x}) = \text{dist}(\mathbf{x}, \mathbf{c}), \quad r_{\mathbf{e}}(\mathbf{x}) = \text{dist}(\mathbf{x}, \mathbf{e}), \quad \rho_{\mathbf{ce}}(\mathbf{x}) = \frac{r_{\mathbf{e}}(\mathbf{x})}{r_{\mathbf{c}}(\mathbf{x})}.$$

There exists $\varepsilon > 0$ small enough such that if we set

$$(5.2a) \quad \begin{aligned} \Omega_{\mathbf{e}} &= \{\mathbf{x} \in \Omega : r_{\mathbf{e}}(\mathbf{x}) < \varepsilon \text{ and } r_{\mathbf{c}}(\mathbf{x}) > \varepsilon/2 \quad \forall \mathbf{c} \in \mathcal{C}_{\mathbf{e}}\}, \\ \Omega_{\mathbf{c}} &= \{\mathbf{x} \in \Omega : r_{\mathbf{c}}(\mathbf{x}) < \varepsilon \text{ and } \rho_{\mathbf{ce}}(\mathbf{x}) > \varepsilon/2 \quad \forall \mathbf{e} \in \mathcal{E}_{\mathbf{c}}\}, \\ \Omega_{\mathbf{ce}} &= \{\mathbf{x} \in \Omega : r_{\mathbf{c}}(\mathbf{x}) < \varepsilon \text{ and } \rho_{\mathbf{ce}}(\mathbf{x}) < \varepsilon\}, \end{aligned}$$

we have the following properties:

$$(5.2b) \quad \left\{ \begin{array}{l} \overline{\Omega}_{\mathbf{e}} \cap \overline{\Omega}_{\mathbf{e}'} = \emptyset, \quad \forall \mathbf{e}' \neq \mathbf{e}, \\ \overline{\mathcal{B}}(\mathbf{c}, \varepsilon) \cap \overline{\mathcal{B}}(\mathbf{c}', \varepsilon) = \emptyset, \quad \forall \mathbf{c}' \neq \mathbf{c}, \\ \overline{\Omega}_{\mathbf{ce}} \cap \overline{\Omega}_{\mathbf{ce}'} = \emptyset, \quad \forall \mathbf{e}' \neq \mathbf{e}. \end{array} \right.$$

We also define the larger neighborhoods with $\varepsilon'' < \varepsilon < \varepsilon'$

$$(5.2c) \quad \begin{aligned} \Omega'_e &= \{\mathbf{x} \in \Omega : r_e(\mathbf{x}) < \varepsilon' \text{ and } r_c(\mathbf{x}) > \varepsilon''/2 \quad \forall \mathbf{c} \in \mathcal{C}_e\}, \\ \Omega'_c &= \{\mathbf{x} \in \Omega : r_c(\mathbf{x}) < \varepsilon' \text{ and } \rho_{ce}(\mathbf{x}) > \varepsilon''/2 \quad \forall \mathbf{e} \in \mathcal{E}_c\}, \\ \Omega'_{ce} &= \{\mathbf{x} \in \Omega : r_c(\mathbf{x}) < \varepsilon' \text{ and } \rho_{ce}(\mathbf{x}) < \varepsilon'\}, \end{aligned}$$

assuming the ε' and ε'' are sufficiently close to ε for the above properties (5.2b) to hold for Ω'_e , Ω'_c , and Ω'_{ce} . We finally introduce the smaller neighborhoods Ω''_e , Ω''_c , and Ω''_{ce} by inverting the roles of ε' and ε'' and set,

$$(5.2d) \quad \Omega_{\mathcal{C}} = \bigcup_{\mathbf{c} \in \mathcal{C}} \Omega''_{\mathbf{c}}, \quad \Omega_{\mathcal{E}} = \bigcup_{\mathbf{e} \in \mathcal{E}} \Omega''_{\mathbf{e}}, \quad \Omega_{\mathcal{C}\mathcal{E}} = \bigcup_{\mathbf{c} \in \mathcal{C}} \bigcup_{\mathbf{e} \in \mathcal{E}_c} \Omega''_{\mathbf{ce}}.$$

We finally define Ω_0 as the remainder:

$$(5.2e) \quad \Omega_0 = \Omega \setminus \overline{\Omega_{\mathcal{C}} \cap \Omega_{\mathcal{E}} \cap \Omega_{\mathcal{C}\mathcal{E}}}.$$

Note that Ω_0 is far from the singular points of Ω . Replacing Ω''_c , Ω''_e and Ω''_{ce} by Ω_c , Ω_e and Ω_{ce} , respectively, in the definitions (5.2d) and (5.2e), we define the larger ‘‘smooth’’ neighborhood Ω'_0 .

Let \mathcal{V} be any subdomain of Ω . We consider the system of local interior and boundary equations

$$(5.3) \quad \begin{cases} L\mathbf{u} = \mathbf{f} & \text{in } \Omega \cap \mathcal{V}, \\ T_{\mathbf{s}}\mathbf{u} = 0 & \text{on } \Gamma_{\mathbf{s}} \cap \overline{\mathcal{V}}, \quad \mathbf{s} \in \mathcal{S}, \\ D_{\mathbf{s}}\mathbf{u} = 0 & \text{on } \Gamma_{\mathbf{s}} \cap \overline{\mathcal{V}}, \quad \mathbf{s} \in \mathcal{S}, \end{cases}$$

where the operators L , $T_{\mathbf{s}}$ and $D_{\mathbf{s}}$ are homogeneous with constant coefficients and form an elliptic system. The choice $\mathcal{V} = \Omega$ gives back the global boundary value problem on the polyhedron Ω .

Definition 5.1. On $\mathcal{V} \subset \Omega$, for $m \in \mathbb{N}$ and $\underline{\beta} = \{\beta_{\mathbf{c}}\}_{\mathbf{c} \in \mathcal{C}} \cup \{\beta_{\mathbf{e}}\}_{\mathbf{e} \in \mathcal{E}}$, the weighted space with homogeneous norm $\mathcal{K}_{\underline{\beta}}^m(\mathcal{V})$ is defined as follows, cf. [28, 29, 6, 7]

$$(5.4) \quad \mathcal{K}_{\underline{\beta}}^m(\mathcal{V}) = \left\{ u \in L^2_{\text{loc}}(\mathcal{V}) : \forall \alpha, |\alpha| \leq m, \quad \partial_{\mathbf{x}}^{\alpha} u \in L^2(\mathcal{V} \cap \Omega_0) \quad \text{and} \right. \\ \left. \begin{aligned} r_{\mathbf{c}}(\mathbf{x})^{\beta_{\mathbf{c}}+|\alpha|} \partial_{\mathbf{x}}^{\alpha} u &\in L^2(\mathcal{V} \cap \Omega_{\mathbf{c}}) \quad \forall \mathbf{c} \in \mathcal{C}, \\ r_{\mathbf{e}}(\mathbf{x})^{\beta_{\mathbf{e}}+|\alpha|} \partial_{\mathbf{x}}^{\alpha} u &\in L^2(\mathcal{V} \cap \Omega_{\mathbf{e}}) \quad \forall \mathbf{e} \in \mathcal{E}, \\ r_{\mathbf{c}}(\mathbf{x})^{\beta_{\mathbf{c}}+|\alpha|} \rho_{\mathbf{ce}}(\mathbf{x})^{\beta_{\mathbf{e}}+|\alpha|} \partial_{\mathbf{x}}^{\alpha} u &\in L^2(\mathcal{V} \cap \Omega_{\mathbf{ce}}) \quad \forall \mathbf{c} \in \mathcal{C}, \forall \mathbf{e} \in \mathcal{E}_c \end{aligned} \right\},$$

and endowed with its natural semi-norms and norm.

Note that the condition in the edge-vertex neighborhood $\Omega_{\mathbf{ce}}$ can be equivalently written as

$$r_{\mathbf{c}}(\mathbf{x})^{\beta_{\mathbf{c}}-\beta_{\mathbf{e}}} r_{\mathbf{e}}(\mathbf{x})^{\beta_{\mathbf{e}}+|\alpha|} \partial_{\mathbf{x}}^{\alpha} u \in L^2(\mathcal{V} \cap \Omega_{\mathbf{ce}}).$$

Remark 5.2. The semi-norms issued from (5.4) are equivalent to the globally defined semi-norms

$$(5.5) \quad \left\{ \sum_{|\alpha|=k} \left\| \left\{ \prod_{\mathbf{c} \in \mathcal{C}} r_{\mathbf{c}}^{\beta_{\mathbf{c}}+|\alpha|} \right\} \left\{ \prod_{\mathbf{e} \in \mathcal{E}} \left(\frac{r_{\mathbf{e}}}{r_{\mathbf{c}'}} \right)^{\beta_{\mathbf{e}}+|\alpha|} \right\} \partial_{\mathbf{x}}^{\alpha} u \right\|_{0;\mathcal{V}}^2 \right\}^{\frac{1}{2}}, \quad k = 0, \dots, m.$$

Here $r_{\mathcal{C}}$ denotes the distance function to the set \mathcal{C} of corners. With this expression, the relations between our spaces $K_{\underline{\beta}}^m(\Omega)$ and the spaces $V_{\vec{\beta}, \vec{\delta}}^{m,p}(\Omega)$ defined in [28, §1.2] or [29, §7.3] become obvious:

$$(5.6) \quad K_{\underline{\beta}}^m(\Omega) = V_{\vec{\beta}, \vec{\delta}}^{m,p}(\Omega) \quad \text{if } p = 2, \quad \vec{\beta} = \{\beta_{\mathbf{c}} + m\}_{\mathbf{c} \in \mathcal{C}}, \quad \vec{\delta} = \{\beta_{\mathbf{e}} + m\}_{\mathbf{e} \in \mathcal{E}}.$$

5.2. Anisotropic weighted spaces with homogeneous norms. Unlike in the conical case, the weighted spaces $K_{\underline{\beta}}^m$ are in a certain sense too large to describe accurately the regularity of solutions of the elliptic problem (5.3) along the directions of edges. Mimicking the definition of the spaces $M_{\underline{\beta}}^m$ in the pure edge case, cf. (4.17), we particularize for each edge $\mathbf{e} \in \mathcal{E}$, the derivatives in the directions transverse or parallel to that edge by the notations

$$(5.7) \quad \partial_{\mathbf{x}}^{\alpha \perp} \text{ (transverse)} \quad \text{and} \quad \partial_{\mathbf{x}}^{\alpha \parallel} \text{ (parallel)}, \quad (\mathbf{e} \in \mathcal{E}),$$

so that

$$\partial_{\mathbf{x}}^{\alpha} = \partial_{\mathbf{x}}^{\alpha \perp} \partial_{\mathbf{x}}^{\alpha \parallel}.$$

Of course these directions are edge dependent. They are well-defined in each of the domains $\Omega_{\mathbf{e}}$ and $\Omega_{\mathbf{ce}}$ determined by the edge \mathbf{e} .

The following spaces were introduced in [6, 7] for similar purposes:

Definition 5.3. On $\mathcal{V} \subset \Omega$, for $m \in \mathbb{N}$ and $\underline{\beta} = \{\beta_{\mathbf{c}}\}_{\mathbf{c} \in \mathcal{C}} \cup \{\beta_{\mathbf{e}}\}_{\mathbf{e} \in \mathcal{E}}$, we define

$$(5.8) \quad M_{\underline{\beta}}^m(\mathcal{V}) = \left\{ u \in L_{\text{loc}}^2(\mathcal{V}) : \forall \alpha, |\alpha| \leq m, \quad \partial_{\mathbf{x}}^{\alpha} u \in L^2(\mathcal{V} \cap \Omega_0) \quad \text{and} \right. \\ \left. \begin{aligned} r_{\mathbf{c}}(\mathbf{x})^{\beta_{\mathbf{c}} + |\alpha|} \partial_{\mathbf{x}}^{\alpha} u &\in L^2(\mathcal{V} \cap \Omega_{\mathbf{c}}) \quad \forall \mathbf{c} \in \mathcal{C}, \\ r_{\mathbf{e}}(\mathbf{x})^{\beta_{\mathbf{e}} + |\alpha \perp|} \partial_{\mathbf{x}}^{\alpha} u &\in L^2(\mathcal{V} \cap \Omega_{\mathbf{e}}) \quad \forall \mathbf{e} \in \mathcal{E}, \\ r_{\mathbf{c}}(\mathbf{x})^{\beta_{\mathbf{c}} + |\alpha|} \rho_{\mathbf{ce}}(\mathbf{x})^{\beta_{\mathbf{e}} + |\alpha \perp|} \partial_{\mathbf{x}}^{\alpha} u &\in L^2(\mathcal{V} \cap \Omega_{\mathbf{ce}}) \quad \forall \mathbf{c} \in \mathcal{C}, \forall \mathbf{e} \in \mathcal{E}_{\mathbf{c}}, \end{aligned} \right\},$$

We denote by $\|\cdot\|_{M; m, \underline{\beta}; \mathcal{V}}$ and $|\cdot|_{M; m, \underline{\beta}; \mathcal{V}}$ its norm and semi-norm, namely

$$\|\cdot\|_{M; m, \underline{\beta}; \mathcal{V}}^2 = \sum_{\ell=0}^m |\cdot|_{M; \ell, \underline{\beta}; \mathcal{V}}^2$$

with

$$(5.9) \quad |u|_{M; \ell, \underline{\beta}; \mathcal{V}}^2 = \sum_{|\alpha|=\ell} \left(\|\partial_{\mathbf{x}}^{\alpha} u\|_{0; \mathcal{V} \cap \Omega_0}^2 + \sum_{\mathbf{c} \in \mathcal{C}} \|r_{\mathbf{c}}^{\beta_{\mathbf{c}} + |\alpha|} \partial_{\mathbf{x}}^{\alpha} u\|_{0; \mathcal{V} \cap \Omega_{\mathbf{c}}}^2 \right. \\ \left. + \sum_{\mathbf{e} \in \mathcal{E}} \|r_{\mathbf{e}}^{\beta_{\mathbf{e}} + |\alpha \perp|} \partial_{\mathbf{x}}^{\alpha} u\|_{0; \mathcal{V} \cap \Omega_{\mathbf{e}}}^2 + \sum_{\mathbf{c} \in \mathcal{C}} \sum_{\mathbf{e} \in \mathcal{E}_{\mathbf{c}}} \|r_{\mathbf{c}}^{\beta_{\mathbf{c}} + |\alpha|} \rho_{\mathbf{ce}}^{\beta_{\mathbf{e}} + |\alpha \perp|} \partial_{\mathbf{x}}^{\alpha} u\|_{0; \mathcal{V} \cap \Omega_{\mathbf{ce}}}^2 \right).$$

Note that the condition in the edge-vertex neighborhood $\Omega_{\mathbf{ce}}$ can be written equivalently as

$$r_{\mathbf{c}}(\mathbf{x})^{\beta_{\mathbf{c}} - \beta_{\mathbf{e}} + \alpha \parallel} r_{\mathbf{e}}(\mathbf{x})^{\beta_{\mathbf{e}} + |\alpha|} \partial_{\mathbf{x}}^{\alpha} u \in L^2(\mathcal{V} \cap \Omega_{\mathbf{ce}}).$$

We can then define the corresponding analytic class as follows:

Definition 5.4. We say that $u \in A_{\underline{\beta}}(\Omega)$ if $u \in M_{\underline{\beta}}^k(\Omega)$ for all $k \geq 0$ and there exists a positive constant C such that

$$|u|_{M; k; \underline{\beta}; \Omega} \leq C^{k+1} k! \quad \forall k \geq 0.$$

We rephrase Assumption 4.3 for the dihedral neighborhood $\Omega_{\mathbf{e}}$:

Assumption 5.5. Let $\mathbf{e} \in \mathcal{E}$ and $\beta_{\mathbf{e}} \in \mathbb{R}$. We assume the following a priori estimate: There is a constant C such that any

$$\mathbf{u} \in \mathbf{K}_{\beta_{\mathbf{e}}}^2(\Omega_{\mathbf{e}}),$$

solution of problem (5.3) in $\mathcal{V} = \Omega'_{\mathbf{e}}$ with $\mathbf{f} \in \mathbf{K}_{\beta_{\mathbf{e}}+2}^0(\Omega'_{\mathbf{e}})$, satisfies:

$$(5.10) \quad \|\mathbf{u}\|_{\mathbf{K}_{\beta_{\mathbf{e}}}^2(\Omega_{\mathbf{e}})} \leq C \left(\|\mathbf{f}\|_{\mathbf{K}_{\beta_{\mathbf{e}}+2}^0(\Omega'_{\mathbf{e}})} + \|\mathbf{u}\|_{\mathbf{K}_{\beta_{\mathbf{e}}+1}^1(\Omega'_{\mathbf{e}})} \right).$$

We can apply Theorem 4.9 to the edge neighborhood $\Omega_{\mathbf{e}}$. We obtain that under Assumption 5.5, any solution $\mathbf{u} \in \mathbf{K}_{\beta_{\mathbf{e}}}^1(\Omega'_{\mathbf{e}})$ of problem (5.3) with $\mathbf{f} \in \mathbf{M}_{\beta_{\mathbf{e}}+2}^n(\Omega'_{\mathbf{e}})$ satisfies the uniform estimates for $0 \leq k \leq n$

$$(5.11) \quad \frac{1}{k!} \left(\sum_{|\alpha|=k} \|r_{\mathbf{e}}^{\beta_{\mathbf{e}}+|\alpha_{\perp}} \partial_{\mathbf{x}}^{\alpha} \mathbf{u}\|_{0; \Omega_{\mathbf{e}}}^2 \right)^{\frac{1}{2}} \leq C^{k+1} \left\{ \sum_{\ell=0}^k \frac{1}{\ell!} \left(\sum_{|\alpha|=\ell} \|r_{\mathbf{e}}^{\beta_{\mathbf{e}}+2+|\alpha_{\perp}} \partial_{\mathbf{x}}^{\alpha} \mathbf{f}\|_{0; \Omega'_{\mathbf{e}}}^2 \right)^{\frac{1}{2}} + \|\mathbf{u}\|_{\mathbf{K}_{\beta_{\mathbf{e}}+1}^1(\Omega'_{\mathbf{e}})} \right\}.$$

Now we consider the edge-vertex domain $\Omega_{\mathbf{ce}}$.

Proposition 5.6. Let $\mathbf{c} \in \mathcal{C}$ and $\mathbf{e} \in \mathcal{E}_{\mathbf{c}}$. Let $\underline{\beta} = \{\beta_{\mathbf{c}}, \beta_{\mathbf{e}}\}$. Under Assumption 5.5, any solution $\mathbf{u} \in \mathbf{K}_{\underline{\beta}}^1(\Omega'_{\mathbf{ce}})$ of problem (5.3) with $\mathbf{f} \in \mathbf{M}_{\underline{\beta}+2}^n(\Omega'_{\mathbf{ce}})$ belongs to $\mathbf{M}_{\underline{\beta}}^n(\Omega_{\mathbf{ce}})$ and satisfies the uniform estimates for $0 \leq k \leq n$

$$(5.12) \quad \frac{1}{k!} \left(\sum_{|\alpha|=k} \|r_{\mathbf{c}}^{\beta_{\mathbf{c}}+|\alpha|} \rho_{\mathbf{ce}}^{\beta_{\mathbf{e}}+|\alpha_{\perp}} \partial_{\mathbf{x}}^{\alpha} \mathbf{u}\|_{0; \Omega_{\mathbf{ce}}}^2 \right)^{\frac{1}{2}} \leq C^{k+1} \left\{ \sum_{\ell=0}^k \frac{1}{\ell!} \left(\sum_{|\alpha|=\ell} \|r_{\mathbf{c}}^{\beta_{\mathbf{c}}+2+|\alpha|} \rho_{\mathbf{ce}}^{\beta_{\mathbf{e}}+2+|\alpha_{\perp}} \partial_{\mathbf{x}}^{\alpha} \mathbf{f}\|_{0; \Omega'_{\mathbf{ce}}}^2 \right)^{\frac{1}{2}} + \|\mathbf{u}\|_{\mathbf{K}_{\underline{\beta}+1}^1(\Omega'_{\mathbf{ce}})} \right\}.$$

Proof. We mimic the proof of Theorem 2.2. The proof of estimate (5.12) is based on a locally finite dyadic covering of $\Omega_{\mathbf{ce}}$ and $\Omega'_{\mathbf{ce}}$. Define, compare with (5.2a)-(5.2c),

$$\begin{aligned} \widehat{\mathcal{V}} &= \{\mathbf{x} \in \Omega : \frac{\varepsilon}{4} < r_{\mathbf{c}}(\mathbf{x}) < \varepsilon \text{ and } \rho_{\mathbf{ce}} < \varepsilon\} \\ \widehat{\mathcal{V}}' &= \{\mathbf{x} \in \Omega : \frac{\varepsilon^2}{4\varepsilon'} < r_{\mathbf{c}}(\mathbf{x}) < \varepsilon' \text{ and } \rho_{\mathbf{ce}} < \varepsilon'\}, \end{aligned}$$

and for $\mu \in \mathbb{N}$:

$$\mathcal{V}_{\mu} = 2^{-\mu} \widehat{\mathcal{V}} \quad \text{and} \quad \mathcal{V}'_{\mu} = 2^{-\mu} \widehat{\mathcal{V}}'.$$

We check:

$$\Omega_{\mathbf{ce}} = \bigcup_{\mu \in \mathbb{N}} \mathcal{V}_{\mu} \quad \text{and} \quad \Omega'_{\mathbf{ce}} = \bigcup_{\mu \in \mathbb{N}} \mathcal{V}'_{\mu}.$$

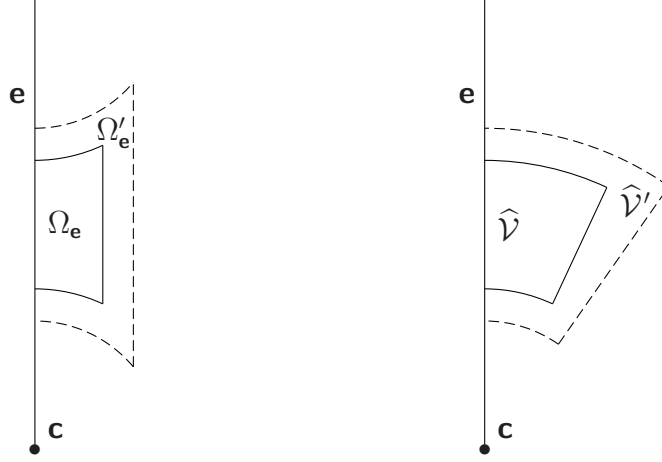

FIGURE 2. Nested edge neighborhoods (section determined by azimuthal angle $\theta_e = \text{constant}$)

The estimate (5.11) between Ω_e and Ω'_e also holds in the configuration of $\hat{\mathcal{V}}$ and $\hat{\mathcal{V}}'$ which is similar: $\hat{\mathcal{V}}$ and $\hat{\mathcal{V}}'$ are *nested edge neighborhoods* which do not touch any corner, see Fig. 2.

Since r_c is bounded from above and from below by strictly positive constants, the distance r_e is equivalent to ρ_{ce} on the reference domains: We have

$$\frac{1}{k!} \left(\sum_{|\alpha|=k} \|\rho_{ce}(\hat{\mathbf{x}})^{\beta_e+|\alpha_\perp|} \partial_{\hat{\mathbf{x}}}^\alpha \hat{\mathbf{u}}\|_{0; \hat{\mathcal{V}}}^2 \right)^{\frac{1}{2}} \leq C^{k+1} \left\{ \sum_{\ell=0}^k \frac{1}{\ell!} \left(\sum_{|\alpha|=\ell} \|\rho_{ce}(\hat{\mathbf{x}})^{\beta_e+2+|\alpha_\perp|} \partial_{\hat{\mathbf{x}}}^\alpha \hat{\mathbf{f}}\|_{0; \hat{\mathcal{V}}'}^2 \right)^{\frac{1}{2}} + \sum_{|\alpha| \leq 1} \|\rho_{ce}(\hat{\mathbf{x}})^{\beta_e+|\alpha|} \partial_{\hat{\mathbf{x}}}^\alpha \hat{\mathbf{u}}\|_{0; \hat{\mathcal{V}}} \right\}.$$

for any reference function $\hat{\mathbf{u}}$ satisfying the boundary conditions of (5.3) and $\hat{\mathbf{f}} := L\hat{\mathbf{u}}$.

For the same reason, we can insert powers of r_c in the above estimate, to obtain our new reference estimate

$$(5.13) \quad \frac{1}{k!} \left(\sum_{|\alpha|=k} \|r_c(\hat{\mathbf{x}})^{\beta_c+|\alpha|} \rho_{ce}(\hat{\mathbf{x}})^{\beta_e+|\alpha_\perp|} \partial_{\hat{\mathbf{x}}}^\alpha \hat{\mathbf{u}}\|_{0; \hat{\mathcal{V}}}^2 \right)^{\frac{1}{2}} \leq C^{k+1} \left\{ \sum_{\ell=0}^k \frac{1}{\ell!} \left(\sum_{|\alpha|=\ell} \|r_c(\hat{\mathbf{x}})^{\beta_c+2+|\alpha|} \rho_{ce}(\hat{\mathbf{x}})^{\beta_e+2+|\alpha_\perp|} \partial_{\hat{\mathbf{x}}}^\alpha \hat{\mathbf{f}}\|_{0; \hat{\mathcal{V}}'}^2 \right)^{\frac{1}{2}} + \sum_{|\alpha| \leq 1} \|r_c(\hat{\mathbf{x}})^{\beta_c+|\alpha|} \rho_{ce}(\hat{\mathbf{x}})^{\beta_e+|\alpha|} \partial_{\hat{\mathbf{x}}}^\alpha \hat{\mathbf{u}}\|_{0; \hat{\mathcal{V}}} \right\}.$$

The change of variables $\hat{\mathbf{x}} \rightarrow \mathbf{x} = 2^{-\mu} \hat{\mathbf{x}}$ maps $\hat{\mathcal{V}}$ to \mathcal{V}_μ (resp. $\hat{\mathcal{V}}'$ to \mathcal{V}'_μ). We note that

$$\rho_{ce}(\hat{\mathbf{x}}) = \rho_{ce}(\mathbf{x}) \quad \text{and} \quad r_c(\hat{\mathbf{x}}) = 2^\mu r_c(\mathbf{x}).$$

With the change of functions

$$\widehat{\mathbf{u}}(\widehat{\mathbf{x}}) := \mathbf{u}(\mathbf{x}) \quad \text{and} \quad \widehat{\mathbf{f}}(\widehat{\mathbf{x}}) := L\widehat{\mathbf{u}}, \quad \text{which implies} \quad \widehat{\mathbf{f}}(\widehat{\mathbf{x}}) = 2^{-2\mu}\mathbf{f}(\mathbf{x}),$$

we deduce from estimate (5.13) that

$$\begin{aligned} \frac{1}{k!} 2^{\mu\beta_{\mathbf{c}}} \left(\sum_{|\alpha|=k} \|r_{\mathbf{c}}(\mathbf{x})^{\beta+|\alpha|} \rho_{\mathbf{c}\mathbf{e}}(\mathbf{x})^{\beta_{\mathbf{e}}+|\alpha_{\perp}|} \partial_{\mathbf{x}}^{\alpha} \mathbf{u}\|_{0; \mathcal{V}}^2 \right)^{\frac{1}{2}} &\leq C^{k+1} \left\{ \right. \\ &\sum_{\ell=0}^k \frac{1}{\ell!} 2^{\mu(\beta_{\mathbf{c}}+2)} \left(\sum_{|\alpha|=\ell} 2^{-2\mu} \|r_{\mathbf{c}}(\mathbf{x})^{\beta+2+|\alpha|} \rho_{\mathbf{c}\mathbf{e}}(\mathbf{x})^{\beta_{\mathbf{e}}+2+|\alpha_{\perp}|} \partial_{\mathbf{x}}^{\alpha} \mathbf{f}\|_{0; \mathcal{V}'}^2 \right)^{\frac{1}{2}} \\ &\left. + \left(2^{\mu\beta_{\mathbf{c}}} \sum_{|\alpha|\leq 1} \|r_{\mathbf{c}}(\mathbf{x})^{\beta_{\mathbf{c}}+|\alpha|} \rho_{\mathbf{c}\mathbf{e}}(\mathbf{x})^{\beta_{\mathbf{e}}+|\alpha|} \partial_{\mathbf{x}}^{\alpha} \mathbf{u}\|_{0; \mathcal{V}'}^2 \right)^{\frac{1}{2}} \right\}. \end{aligned}$$

Multiplying this identity by $2^{-\mu\beta}$, taking squares, and summing up over all μ , we get the requested estimate (5.12). \square

The estimates in pure vertex domains $\Omega_{\mathbf{c}}$ (i.e., close to corners but “relatively far” from the edges) are similar to those in obtained in Theorem 2.2 for plane sectors:

Proposition 5.7. *Let $\mathbf{c} \in \mathcal{C}$ and $\underline{\beta} = \{\beta_{\mathbf{c}}\}$. Any solution $\mathbf{u} \in \mathbf{K}_{\underline{\beta}}^1(\Omega'_{\mathbf{c}})$ of problem (5.3) with $\mathbf{f} \in \mathbf{M}_{\underline{\beta}+2}^{n-2}(\Omega'_{\mathbf{c}})$ belongs to $\mathbf{M}_{\underline{\beta}}^n(\Omega_{\mathbf{c}})$ and satisfies the uniform estimates for $0 \leq k \leq n$*

$$(5.14) \quad \frac{1}{k!} \left(\sum_{|\alpha|=k} \|r_{\mathbf{c}}^{\beta_{\mathbf{c}}+|\alpha|} \partial_{\mathbf{x}}^{\alpha} \mathbf{u}\|_{0; \Omega_{\mathbf{c}}}^2 \right)^{\frac{1}{2}} \leq C^{k+1} \left\{ \right. \\ \left. \sum_{\ell=0}^{k-2} \frac{1}{\ell!} \left(\sum_{|\alpha|=\ell} \|r_{\mathbf{c}}^{\beta_{\mathbf{c}}+2+|\alpha|} \partial_{\mathbf{x}}^{\alpha} \mathbf{f}\|_{0; \Omega'_{\mathbf{c}}}^2 \right)^{\frac{1}{2}} + \|\mathbf{u}\|_{\mathbf{K}_{\underline{\beta}+1}^1(\Omega'_{\mathbf{c}})} \right\}.$$

Proof. The proof is again based on the argument of dyadic partitions with reference domains defined as

$$\widehat{\mathcal{V}} = \{\mathbf{x} \in \Omega_{\mathbf{c}}, \quad \frac{\varepsilon}{4} < r_{\mathbf{c}}(\mathbf{x}) < \varepsilon\} \quad \text{and} \quad \widehat{\mathcal{V}}' = \{\mathbf{x} \in \Omega'_{\mathbf{c}}, \quad \frac{\varepsilon^2}{4\varepsilon'} < r_{\mathbf{c}}(\mathbf{x}) < \varepsilon'\}.$$

and for $\mu \in \mathbb{N}$:

$$\mathcal{V}_{\mu} = 2^{-\mu}\widehat{\mathcal{V}} \quad \text{and} \quad \mathcal{V}'_{\mu} = 2^{-\mu}\widehat{\mathcal{V}}'.$$

We check:

$$\Omega_{\mathbf{c}} = \bigcup_{\mu \in \mathbb{N}} \mathcal{V}_{\mu} \quad \text{and} \quad \Omega'_{\mathbf{c}} = \bigcup_{\mu \in \mathbb{N}} \mathcal{V}'_{\mu}.$$

We can apply the a priori estimates of the smooth case between $\widehat{\mathcal{V}}$ and $\widehat{\mathcal{V}}'$, cf. (2.9) and deduce (5.14) in the same way. \square

We obtain now the anisotropic regularity shift in homogeneous weighted spaces on polyhedra :

Theorem 5.8. *Let Ω be a polyhedron and $\underline{\beta} = \{\beta_{\mathbf{c}}, \beta_{\mathbf{e}}\}$ be a weight multi-exponent. Let Assumption 5.5 be satisfied for all edges $\mathbf{e} \in \mathcal{E}$. Let $\mathbf{u} \in \mathbf{H}_{\text{loc}}^2(\overline{\Omega} \setminus \mathcal{E})$ be a solution of problem (5.3). Then the following implications hold*

$$(5.15a) \quad \mathbf{u} \in \mathbf{K}_{\underline{\beta}}^1(\Omega) \text{ and } \mathbf{f} \in \mathbf{M}_{\underline{\beta}+2}^m(\Omega) \implies \mathbf{u} \in \mathbf{M}_{\underline{\beta}}^m(\Omega) \quad (m \in \mathbb{N}),$$

$$(5.15b) \quad \mathbf{u} \in \mathbf{K}_{\underline{\beta}}^1(\Omega) \text{ and } \mathbf{f} \in \mathbf{A}_{\underline{\beta}+2}(\Omega) \implies \mathbf{u} \in \mathbf{A}_{\underline{\beta}}(\Omega).$$

Proof. The proof is a consequence of

- (i) elliptic estimates in the smooth case applied between Ω_0 and Ω'_0 ,
- (ii) pure corner estimates (5.14),
- (iii) edge estimates (5.11) between the pure edge domains $\Omega_{\mathbf{e}}$ and $\Omega'_{\mathbf{e}}$,
- (iv) edge-vertex estimates (5.12).

□

5.3. Anisotropic weighted spaces with non-homogeneous norms. For the same reason as in the two-dimensional case, it is valuable to have alternative statements to (5.15a) and (5.15b) in which the a priori condition $\mathbf{u} \in \mathbf{K}_{\underline{\beta}}^1(\Omega)$ can be replaced by the weaker condition $\mathbf{u} \in \mathbf{J}_{\underline{\beta}}^1(\Omega)$.

Definition 5.9. For $\underline{\beta} = \{\beta_{\mathbf{c}}, \beta_{\mathbf{e}}\}$ and $n \in \mathbb{N}$, let us introduce the isotropic weighted space

$$(5.16) \quad \mathbf{J}_{\underline{\beta}}^n(\mathcal{V}) = \left\{ u \in \mathbf{L}_{\text{loc}}^2(\mathcal{V}) : \forall \alpha, |\alpha| \leq n, \quad \partial_{\mathbf{x}}^{\alpha} u \in \mathbf{L}^2(\mathcal{V} \cap \Omega_0) \quad \text{and} \right. \\ \left. \begin{aligned} r_{\mathbf{c}}(\mathbf{x})^{\beta_{\mathbf{c}}+n} \partial_{\mathbf{x}}^{\alpha} u &\in \mathbf{L}^2(\mathcal{V} \cap \Omega_{\mathbf{c}}) \quad \forall \mathbf{c} \in \mathcal{C}, \\ r_{\mathbf{e}}(\mathbf{x})^{\beta_{\mathbf{e}}+n} \partial_{\mathbf{x}}^{\alpha} u &\in \mathbf{L}^2(\mathcal{V} \cap \Omega_{\mathbf{e}}) \quad \forall \mathbf{e} \in \mathcal{E}, \\ r_{\mathbf{c}}(\mathbf{x})^{\beta_{\mathbf{c}}+n} \rho_{\mathbf{ce}}(\mathbf{x})^{\beta_{\mathbf{e}}+n} \partial_{\mathbf{x}}^{\alpha} u &\in \mathbf{L}^2(\mathcal{V} \cap \Omega_{\mathbf{ce}}) \quad \forall \mathbf{c} \in \mathcal{C}, \forall \mathbf{e} \in \mathcal{E}_{\mathbf{c}} \end{aligned} \right\},$$

and its anisotropic companion, for $n > -\min\{\min_{\mathbf{c} \in \mathcal{C}} \beta_{\mathbf{c}}, \min_{\mathbf{e} \in \mathcal{E}} \beta_{\mathbf{e}}\}$, cf. (4.25)

$$(5.17) \quad \mathbf{N}_{\underline{\beta}}^n(\mathcal{V}) = \left\{ u \in \mathbf{L}_{\text{loc}}^2(\mathcal{V}) : \forall \alpha, |\alpha| \leq n, \quad \partial_{\mathbf{x}}^{\alpha} u \in \mathbf{L}^2(\mathcal{V} \cap \Omega_0) \quad \text{and} \right. \\ \left. \begin{aligned} r_{\mathbf{c}}(\mathbf{x})^{\max\{\beta_{\mathbf{c}}+|\alpha|, 0\}} \partial_{\mathbf{x}}^{\alpha} u &\in \mathbf{L}^2(\mathcal{V} \cap \Omega_{\mathbf{c}}) \quad \forall \mathbf{c} \in \mathcal{C}, \\ r_{\mathbf{e}}(\mathbf{x})^{\max\{\beta_{\mathbf{e}}+|\alpha|, 0\}} \partial_{\mathbf{x}}^{\alpha} u &\in \mathbf{L}^2(\mathcal{V} \cap \Omega_{\mathbf{e}}) \quad \forall \mathbf{e} \in \mathcal{E}, \\ r_{\mathbf{c}}(\mathbf{x})^{\max\{\beta_{\mathbf{c}}+|\alpha|, 0\}} \rho_{\mathbf{ce}}(\mathbf{x})^{\max\{\beta_{\mathbf{e}}+|\alpha|, 0\}} \partial_{\mathbf{x}}^{\alpha} u &\in \mathbf{L}^2(\mathcal{V} \cap \Omega_{\mathbf{ce}}) \quad \forall \mathbf{c} \in \mathcal{C}, \forall \mathbf{e} \in \mathcal{E}_{\mathbf{c}} \end{aligned} \right\}.$$

We note that, like in the case of \mathbf{K} -weighted spaces, the semi-norms issued from (5.16) are equivalent to the globally defined semi-norms, compare with (5.5)

$$(5.18) \quad \left\{ \sum_{|\alpha|=k} \left\| \left\{ \prod_{\mathbf{c} \in \mathcal{C}} r_{\mathbf{c}}^{\beta_{\mathbf{c}}+n} \right\} \left\{ \prod_{\mathbf{e} \in \mathcal{E}} \left(\frac{r_{\mathbf{e}}}{r_{\mathbf{c}}} \right)^{\beta_{\mathbf{e}}+n} \right\} \partial_{\mathbf{x}}^{\alpha} u \right\|_{0; \mathcal{V}}^2 \right\}^{\frac{1}{2}}, \quad k = 0, \dots, n.$$

It is useful to introduce, in the same spirit as in [29], a full range of intermediate spaces between $\mathbf{K}_{\underline{\beta}}^n(\Omega)$ and $\mathbf{J}_{\underline{\beta}}^n(\Omega)$.

Definition 5.10. Let us flag a subset \mathcal{C}_0 of corners and a subset \mathcal{E}_0 of edges, and define $J_{\underline{\beta}}^n(\mathcal{V}; \mathcal{C}_0, \mathcal{E}_0)$ as the space of functions such that all semi-norms

$$(5.19) \quad \left\| \left\{ \prod_{\mathbf{c} \in \mathcal{C}_0} r_{\mathbf{c}}^{\beta_{\mathbf{c}} + |\alpha|} \right\} \left\{ \prod_{\mathbf{c} \in \mathcal{C} \setminus \mathcal{C}_0} r_{\mathbf{c}}^{\beta_{\mathbf{c}} + n} \right\} \left\{ \prod_{\mathbf{e} \in \mathcal{E}_0} \left(\frac{r_{\mathbf{e}}}{r_{\mathcal{E}}} \right)^{\beta_{\mathbf{e}} + |\alpha|} \right\} \left\{ \prod_{\mathbf{e} \in \mathcal{E} \setminus \mathcal{E}_0} \left(\frac{r_{\mathbf{e}}}{r_{\mathcal{E}}} \right)^{\beta_{\mathbf{e}} + n} \right\} \partial_{\mathbf{x}}^{\alpha} u \right\|_{0; \mathcal{V}}$$

are finite for $|\alpha| \leq n$. Anisotropic spaces $N_{\underline{\beta}}^n(\mathcal{V}; \mathcal{C}_0, \mathcal{E}_0)$ are defined similarly, replacing in (5.17) the weight $r_{\mathbf{c}}^{\max\{\beta_{\mathbf{c}} + |\alpha|, 0\}}$ by $r_{\mathbf{c}}^{\beta_{\mathbf{c}} + |\alpha|}$ when $\mathbf{c} \in \mathcal{C}_0$, and $\{r_{\mathbf{e}}, \rho_{\mathbf{ce}}\}^{\max\{\beta_{\mathbf{e}} + |\alpha|, 0\}}$ by $\{r_{\mathbf{e}}, \rho_{\mathbf{ce}}\}^{\beta_{\mathbf{e}} + |\alpha|}$ when $\mathbf{e} \in \mathcal{E}_0$. The sum of the squares of these contributions for $|\alpha| = n$ defines the squared semi-norm

$$|u|_{N_{\underline{\beta}}^n(\mathcal{V}; \mathcal{C}_0, \mathcal{E}_0)}^2.$$

Note that with $\mathcal{C}_0 = \mathcal{E}_0 = \emptyset$, we obtain the maximal spaces already introduced in (5.16) and (5.17):

$$(5.20) \quad J_{\underline{\beta}}^n(\mathcal{V}) = J_{\underline{\beta}}^n(\mathcal{V}; \emptyset, \emptyset); \quad N_{\underline{\beta}}^n(\mathcal{V}) = N_{\underline{\beta}}^n(\mathcal{V}; \emptyset, \emptyset).$$

The corresponding analytic class is defined as usual:

Definition 5.11. We say that $u \in B_{\underline{\beta}}(\Omega; \mathcal{C}_0, \mathcal{E}_0)$ if $u \in N_{\underline{\beta}}^k(\Omega; \mathcal{C}_0, \mathcal{E}_0)$ for all $k > k_{\underline{\beta}} := -\min\{\min_{\mathbf{c} \in \mathcal{C}} \beta_{\mathbf{c}}, \min_{\mathbf{e} \in \mathcal{E}} \beta_{\mathbf{e}}\}$ and there exists a positive constant C such that

$$|u|_{N_{\underline{\beta}}^k(\Omega; \mathcal{C}_0, \mathcal{E}_0)} \leq C^{k+1} k! \quad \forall k > k_{\underline{\beta}}.$$

In accordance with (5.20), we write $B_{\underline{\beta}}(\Omega)$ for $B_{\underline{\beta}}(\Omega; \emptyset, \emptyset)$.

Remark 5.12. (i) Choosing $\mathcal{C}_0 = \mathcal{C}$ and $\mathcal{E}_0 = \mathcal{E}$, we find that the spaces $J_{\underline{\beta}}^n(\Omega; \mathcal{C}, \mathcal{E})$, $N_{\underline{\beta}}^n(\Omega; \mathcal{C}, \mathcal{E})$ and $B_{\underline{\beta}}(\Omega; \mathcal{C}, \mathcal{E})$ coincide with the homogeneous spaces $K_{\underline{\beta}}^n(\Omega)$, $M_{\underline{\beta}}^n(\Omega)$ and $A_{\underline{\beta}}(\Omega)$, respectively.

(ii) The following relations hold between our spaces $J_{\underline{\beta}}^m(\Omega; \mathcal{C}_0, \mathcal{E}_0)$ and the spaces $W_{\vec{\beta}, \vec{\delta}}^{m,p}(\Omega)$ of Maz'ya and Rossmann [29]:

$$(5.21) \quad J_{\underline{\beta}}^m(\Omega; \mathcal{C}, \emptyset) = W_{\vec{\beta}, \vec{\delta}}^{m,p}(\Omega) \quad \text{if } p = 2, \quad \vec{\beta} = \{\beta_{\mathbf{c}} + m\}_{\mathbf{c} \in \mathcal{C}}, \quad \vec{\delta} = \{\beta_{\mathbf{e}} + m\}_{\mathbf{e} \in \mathcal{E}}.$$

In these spaces, the non-homogeneity is only related to *edges*. Under the same condition as in (5.21), the intermediate spaces $W_{\vec{\beta}, \vec{\delta}}^{m,p}(\Omega; \tilde{J})$ of [29, § 7.3] coincide with our spaces $J_{\underline{\beta}}^m(\Omega; \mathcal{C}, \mathcal{E}_0)$ if \mathcal{E}_0 is chosen as the same set of edges as \tilde{J} .

(iii) Our analytic class $B_{\underline{\beta}}(\Omega)$ coincides with the so-called countably normed spaces $B_{\vec{\beta}}^{\ell}(\Omega)$ introduced by Guo in [13]: If Guo's edge and corner exponents $\beta_{ij} \in (0, 1)$ and $\beta_m \in (0, \frac{1}{2})$ satisfy $\beta_{ij} = \beta_{\mathbf{e}} + \ell$ and $\beta_m = \beta_{\mathbf{c}} + \ell$, respectively, then $B_{\vec{\beta}}^{\ell}(\Omega) = B_{\underline{\beta}}(\Omega)$.

We state the assumption for J-weighted spaces corresponding to Assumption 4.10 for the dihedral neighborhood $\Omega_{\mathbf{e}}$:

Assumption 5.13. Let $\mathbf{e} \in \mathcal{E}$. Let $m \geq 1$ be an integer. Let $\beta_{\mathbf{e}} \in \mathbb{R}$ such that $\beta_{\mathbf{e}} + m > -1$. We assume the following a priori estimate: There is a constant C such that any

$$\mathbf{u} \in \mathbf{J}_{\beta_{\mathbf{e}}}^{m+1}(\Omega_{\mathbf{e}}),$$

solution of problem (5.3) in $\mathcal{V} = \Omega'_e$ with $\mathbf{f} \in \mathbf{J}_{\beta_e+2}^{m-1}(\Omega'_e)$, satisfies:

$$(5.22) \quad \|\mathbf{u}\|_{\mathbf{J}_{\beta_e}^{m+1}(\Omega_e)} \leq C \left(\|\mathbf{f}\|_{\mathbf{J}_{\beta_e+2}^{m-1}(\Omega'_e)} + \|\mathbf{u}\|_{\mathbf{J}_{\beta_e+1}^m(\Omega'_e)} \right).$$

We then have the following anisotropic regularity shift result in the *non-homogeneous* weighted spaces $\mathbf{N}_{\underline{\beta}}^n(\Omega; \mathcal{C}, \emptyset)$ and $\mathbf{B}_{\underline{\beta}}(\Omega; \mathcal{C}, \emptyset)$:

Theorem 5.14. *Let Ω be a polyhedron and $\underline{\beta} = \{\beta_c, \beta_e\}$ be a weight multi-exponent. Let $m \geq 1$ be an integer such that $\beta_e + m > -1$ for all edges. Let Assumption 5.13 be satisfied for all $\mathbf{e} \in \mathcal{E}$. Let $\mathbf{u} \in \mathbf{H}_{\text{loc}}^2(\overline{\Omega} \setminus \mathcal{E})$ be a solution of problem (5.3) in $\mathcal{V} = \Omega$. Then the following implications hold*

$$(5.23) \quad \begin{aligned} \mathbf{u} \in \mathbf{J}_{\underline{\beta}}^m(\Omega; \mathcal{C}, \emptyset) \text{ and } \mathbf{f} \in \mathbf{N}_{\underline{\beta}+2}^n(\Omega; \mathcal{C}, \emptyset) &\implies \mathbf{u} \in \mathbf{N}_{\underline{\beta}}^n(\Omega; \mathcal{C}, \emptyset) \quad (n > m), \\ \mathbf{u} \in \mathbf{J}_{\underline{\beta}}^m(\Omega; \mathcal{C}, \emptyset) \text{ and } \mathbf{f} \in \mathbf{B}_{\underline{\beta}+2}(\Omega; \mathcal{C}, \emptyset) &\implies \mathbf{u} \in \mathbf{B}_{\underline{\beta}}(\Omega; \mathcal{C}, \emptyset). \end{aligned}$$

Proof. The proof is a consequence of suitable a priori estimates with analytic control in the four types of regions in the polyhedron:

(i) Elliptic estimates in the smooth case can be applied between Ω_0 and Ω'_0 .

(ii) Pure corner estimates (5.14) are valid here: We note that in the pure corner region Ω_c the norms in K and J spaces, or in M and N spaces, are the same.

(iii) The edge estimates (4.26) are valid between the pure edge domains Ω_e and Ω'_e .

(iv) Finally, edge-vertex estimates are proved by the dyadic partition argument starting from the same reference domains $\widehat{\mathcal{V}}$ and $\widehat{\mathcal{V}}'$ as in the proof of Proposition 5.6. The reference estimate can be written as

$$(5.24) \quad \frac{1}{k!} \left(\sum_{|\alpha|=k} \|r_{\mathbf{e}}^{\max\{\beta_e+|\alpha_{\perp}|, 0\}} \partial_{\mathbf{x}}^{\alpha} \widehat{\mathbf{u}}\|_{0; \widehat{\mathcal{V}}}^2 \right)^{\frac{1}{2}} \leq C^{k+1} \left\{ \sum_{\ell=0}^k \frac{1}{\ell!} \left(\sum_{|\alpha|=\ell} \|r_{\mathbf{e}}^{\max\{\beta_e+2+|\alpha_{\perp}|, 0\}} \partial_{\mathbf{x}}^{\alpha} \widehat{\mathbf{f}}\|_{0; \widehat{\mathcal{V}}'}^2 \right)^{\frac{1}{2}} + \left(\sum_{|\alpha| \leq m} \|r_{\mathbf{e}}^{\max\{\beta_e+|\alpha|, 0\}} \partial_{\mathbf{x}}^{\alpha} \widehat{\mathbf{u}}\|_{0; \widehat{\mathcal{V}}'}^2 \right)^{\frac{1}{2}} \right\}.$$

Since r_c and $(r_c)^{-1}$ are bounded on the reference domains, we can

- replace $r_{\mathbf{e}}$ by $\rho_{\mathbf{ce}}$
- insert powers of r_c

in the previous estimate, thus obtaining

$$\frac{1}{k!} \left(\sum_{|\alpha|=k} \|r_{\mathbf{c}}^{\beta_c+|\alpha|} \rho_{\mathbf{ce}}^{\max\{\beta_e+|\alpha_{\perp}|, 0\}} \partial_{\mathbf{x}}^{\alpha} \widehat{\mathbf{u}}\|_{0; \widehat{\mathcal{V}}}^2 \right)^{\frac{1}{2}} \leq C^{k+1} \left\{ \sum_{\ell=0}^k \frac{1}{\ell!} \left(\sum_{|\alpha|=\ell} \|r_{\mathbf{c}}^{\beta_c+2+|\alpha|} \rho_{\mathbf{ce}}^{\max\{\beta_e+2+|\alpha_{\perp}|, 0\}} \partial_{\mathbf{x}}^{\alpha} \widehat{\mathbf{f}}\|_{0; \widehat{\mathcal{V}}'}^2 \right)^{\frac{1}{2}} + \left(\sum_{|\alpha| \leq m} \|r_{\mathbf{c}}^{\beta_c+|\alpha|} \rho_{\mathbf{ce}}^{\max\{\beta_e+|\alpha|, 0\}} \partial_{\mathbf{x}}^{\alpha} \widehat{\mathbf{u}}\|_{0; \widehat{\mathcal{V}}'}^2 \right)^{\frac{1}{2}} \right\}.$$

Owing to the homogeneity of the weights with respect to $r_{\mathbf{c}}$, the dyadic partition argument yields the desired edge-vertex estimate, which allows to conclude the proof of the theorem. \square

Remark 5.15. (i) If we replace Assumption 5.13 by Assumption 5.5 for edges \mathbf{e} in the flagged subset \mathcal{E}_0 , we can prove, instead of (5.23), the implications

$$(5.25) \quad \begin{aligned} \mathbf{u} \in \mathbf{J}_{\underline{\beta}}^m(\Omega; \mathcal{C}, \mathcal{E}_0) \text{ and } \mathbf{f} \in \mathbf{N}_{\underline{\beta}+2}^n(\Omega; \mathcal{C}, \mathcal{E}_0) &\implies \mathbf{u} \in \mathbf{N}_{\underline{\beta}}^n(\Omega; \mathcal{C}, \mathcal{E}_0), \\ \mathbf{u} \in \mathbf{J}_{\underline{\beta}}^m(\Omega; \mathcal{C}, \mathcal{E}_0) \text{ and } \mathbf{f} \in \mathbf{B}_{\underline{\beta}+2}(\Omega; \mathcal{C}, \mathcal{E}_0) &\implies \mathbf{u} \in \mathbf{B}_{\underline{\beta}}(\Omega; \mathcal{C}, \mathcal{E}_0). \end{aligned}$$

(ii) Under Assumption 5.13, the implications in the maximal non-homogeneous spaces, i.e., with $\mathcal{C}_0 = \mathcal{E}_0 = \emptyset$, are also true:

$$(5.26) \quad \begin{aligned} \mathbf{u} \in \mathbf{J}_{\underline{\beta}}^m(\Omega) \text{ and } \mathbf{f} \in \mathbf{N}_{\underline{\beta}+2}^n(\Omega) &\implies \mathbf{u} \in \mathbf{N}_{\underline{\beta}}^n(\Omega), \\ \mathbf{u} \in \mathbf{J}_{\underline{\beta}}^m(\Omega) \text{ and } \mathbf{f} \in \mathbf{B}_{\underline{\beta}+2}(\Omega) &\implies \mathbf{u} \in \mathbf{B}_{\underline{\beta}}(\Omega). \end{aligned}$$

If $\beta_{\mathbf{c}} > -\frac{3}{2}$ for any corner \mathbf{c} , the statements (5.23) and (5.26) coincide, since in this case the spaces $\mathbf{J}_{\underline{\beta}}^m(\Omega; \mathcal{C}, \emptyset)$ and $\mathbf{J}_{\underline{\beta}}^m(\Omega)$ are the same (consequence of Hardy's inequality). In the general case (5.26) can be proved by two different methods:

- Deduced from (5.23) by an argument of corner asymptotics (at each corner, the asymptotics modulo $\mathbf{J}_{\underline{\beta}}^m(\Omega; \mathcal{C}, \emptyset)$ contains only polynomials): For instance when $m = 1$, if $\beta_{\mathbf{c}} \in (-\frac{5}{2}, -\frac{3}{2})$ for all corners \mathbf{c} , any element of $\mathbf{u} \in \mathbf{J}_{\underline{\beta}}^m(\Omega)$ splits as

$$\mathbf{u} = \mathbf{u}_{\mathbf{c}} + \mathbf{w}_{\mathbf{c}} \quad \text{in } \Omega_{\mathbf{c}}, \quad \text{with } \mathbf{u}_{\mathbf{c}} \in \mathbf{J}_{\underline{\beta}}^m(\Omega; \mathcal{C}; \emptyset), \quad \mathbf{w}_{\mathbf{c}} \in \mathbb{C}^N,$$

and we can apply (5.23) locally near each corner, to each function $\mathbf{u}_{\mathbf{c}}$.

- Directly proved by the same method as for Theorem 5.14, starting with the reference estimate for $k \geq m$

$$\begin{aligned} \frac{1}{k!} \left(\sum_{|\alpha|=k} \|r_{\mathbf{e}}^{\max\{\beta_{\mathbf{e}}+|\alpha_{\perp}|, 0\}} \partial_{\mathbf{x}}^{\alpha} \widehat{\mathbf{u}}\|_{0; \widehat{\mathcal{V}}}\|^2 \right)^{\frac{1}{2}} &\leq C^{k+1} \left\{ \right. \\ &\quad \sum_{\ell=m-1}^k \frac{1}{\ell!} \left(\sum_{|\alpha|=\ell} \|r_{\mathbf{e}}^{\max\{\beta_{\mathbf{e}}+2+|\alpha_{\perp}|, 0\}} \partial_{\mathbf{x}}^{\alpha} \widehat{\mathbf{f}}\|_{0; \widehat{\mathcal{V}}'}\|^2 \right)^{\frac{1}{2}} \\ &\quad \left. + \left(\sum_{|\alpha|=m} \|r_{\mathbf{e}}^{\max\{\beta_{\mathbf{e}}+|\alpha|, 0\}} \partial_{\mathbf{x}}^{\alpha} \widehat{\mathbf{u}}\|_{0; \widehat{\mathcal{V}}'}\|^2 \right)^{\frac{1}{2}} \right\}, \end{aligned}$$

instead of (5.24): The $\mathbf{J}_{\underline{\beta}_{\mathbf{e}}}^m$ norm present in (5.24) is replaced here by the corresponding semi-norm, cf. Corollary 1.2.

6. ANALYTIC WEIGHTED REGULARITY OF VARIATIONAL SOLUTIONS

In this section, we investigate how Theorem 3.4 in the polygonal case, or Theorems 5.8 and 5.14 in the polyhedral case, apply to solutions of variational problems.

Let Ω be a polygon or a polyhedron. In coherence with the previous sections, we consider a sesquilinear form \mathfrak{a} , homogeneous of order 1 and with constant coefficients acting

on vector-valued functions with N components

$$(6.1) \quad \mathbf{a}(\mathbf{u}, \mathbf{v}) = \sum_{i=1}^N \sum_{j=1}^N \sum_{|\alpha|=1} \sum_{|\gamma|=1} \int_{\Omega} a_{ij}^{\alpha\gamma} \partial_{\mathbf{x}}^{\alpha} u_j(\mathbf{x}) \partial_{\mathbf{x}}^{\gamma} \bar{v}_i(\mathbf{x}) \, d\mathbf{x},$$

and a subspace \mathbf{V} of $H^1(\Omega)^N =: \mathbf{H}^1(\Omega)$ defined by essential boundary conditions on the sides $\Gamma_{\mathbf{s}}$ of Ω

$$(6.2) \quad \mathbf{V} = \{\mathbf{u} \in \mathbf{H}^1(\Omega) : D_{\mathbf{s}}\mathbf{u} = 0 \text{ on } \Gamma_{\mathbf{s}}, \mathbf{s} \in \mathcal{S}\}.$$

We assume that the form \mathbf{a} is *coercive* on \mathbf{V} :

$$\exists c, C > 0, \quad \forall \mathbf{u} \in \mathbf{V}, \quad \operatorname{Re} \mathbf{a}(\mathbf{u}, \mathbf{u}) \geq c \|\mathbf{u}\|_{1;\Omega}^2 - C \|\mathbf{u}\|_{0;\Omega}^2.$$

Standard examples of such sesquilinear forms are the gradient form for scalar functions

$$\mathbf{a}_{\nabla}(u, v) = \int_{\Omega} \nabla u(\mathbf{x}) \cdot \nabla \bar{v}(\mathbf{x}) \, d\mathbf{x}$$

and the stress-strain sesquilinear forms in linear elasticity:

$$\mathbf{a}_{\text{ela}} = \int_{\Omega} \sigma(\mathbf{u})(\mathbf{x}) : \overline{\varepsilon(\mathbf{v})}(\mathbf{x}) \, d\mathbf{x},$$

where ε is the symmetrized gradient tensor and $\sigma = A\varepsilon$, where A is a material tensor with the usual symmetry and positivity properties. Variational spaces \mathbf{V} on which \mathbf{a}_{∇} is coercive can be defined by any subset \mathcal{S}_D of the set of sides \mathcal{S} :

$$\mathbf{V} = \{u \in H^1(\Omega) : u|_{\Gamma_{\mathbf{s}}} = 0 \quad \forall \mathbf{s} \in \mathcal{S}_D\}.$$

As for \mathbf{a}_{ela} we can take for \mathbf{V} any space of the type

$$\mathbf{V} = \{\mathbf{u} \in \mathbf{H}^1(\Omega) : \mathbf{u}|_{\Gamma_{\mathbf{s}}} = 0 \quad \forall \mathbf{s} \in \mathcal{S}_D, \quad \mathbf{u} \cdot \mathbf{n}|_{\Gamma_{\mathbf{s}}} = 0 \quad \forall \mathbf{s} \in \mathcal{S}_T \\ \text{and } \mathbf{u} \times \mathbf{n}|_{\Gamma_{\mathbf{s}}} = 0 \quad \forall \mathbf{s} \in \mathcal{S}_N\},$$

where \mathbf{n} is the outward unit normal vector to $\Gamma_{\mathbf{s}}$, and \mathcal{S}_D , \mathcal{S}_T , and \mathcal{S}_N are disjoint subsets of \mathcal{S} . As a consequence of Korn's inequality, \mathbf{a}_{ela} is coercive on such spaces \mathbf{V} .

We consider the variational problem

$$(6.3) \quad \text{Find } \mathbf{u} \in \mathbf{V} \text{ such that } \forall \mathbf{v} \in \mathbf{V}, \quad \mathbf{a}(\mathbf{u}, \mathbf{v}) = \int_{\Omega} \mathbf{f} \bar{\mathbf{v}} \, d\mathbf{x}.$$

Having the analytic shift results of Theorems 3.4, 5.8 and 5.14 at hand, the issue is to find suitable exponents $\underline{\beta}$ so that

- (1) $\mathbf{A}_{\underline{\beta}}(\Omega)$ or $\mathbf{B}_{\underline{\beta}}(\Omega)$ are compactly embedded in $\mathbf{H}^1(\Omega)$, — in order to be useful in error analysis for example.
- (2) Variational solutions \mathbf{u} with sufficiently smooth right hand sides belong to $\mathbf{K}_{\underline{\beta}}^1(\Omega)$ or $\mathbf{J}_{\underline{\beta}}^1(\Omega)$.

Condition (1) of compact embedding is satisfied on two- and three-dimensional domains for all $\underline{\beta} < -1$ (this means that all components $\beta_{\mathbf{c}}$ and $\beta_{\mathbf{e}}$ are < -1). This is the reason why we exhibit weights of the form $\underline{\beta} = -\underline{b} - 1$ with $\underline{b} > 0$ in the statements below.

6.1. Regularity of variational solutions in polygons. Let Ω be a polygon with vertices $\mathbf{c} \in \mathcal{C}$. The standard Sobolev space $H^1(\Omega)$ coincides with $J_{-1}^1(\Omega)$, see (3.4). From Remark 3.3 (ii), we know that for the comparison of $J_{-1}^1(\Omega)$ with $\mathbf{K}_{-1}^1(\Omega)$ we are in a critical case, namely a function $u \in H^1(\Omega)$ neither has point values at corners nor satisfies $r^{-1}u \in L^2(\Omega)$ in general (see [22]). There holds $\mathbf{K}_{-1}^1(\Omega) \subset J_{-1}^1(\Omega) \subset \mathbf{K}_{-1+\varepsilon}^1(\Omega)$ for all $\varepsilon > 0$.

Taking the essential boundary conditions into account that define the variational space $\mathbf{V} \subset \mathbf{H}^1(\Omega)$, one will sometimes find that \mathbf{V} is embedded in $\mathbf{K}_{-1}^1(\Omega)$. This happens in particular if each corner lies on at least one side on which Dirichlet conditions are imposed. In the general case, one will just have $\mathbf{V} \subset \mathbf{K}_{-1+\varepsilon}^1(\Omega)$ for all $\varepsilon > 0$. Necessary and sufficient conditions for the embedding $\mathbf{V} \subset \mathbf{K}_{-1}^1(\Omega)$ are discussed in [9, Ch. 14].

The analytic regularity shift (3.12b) in classes $\mathbf{A}_{\underline{\beta}}(\Omega)$ can be applied to variational solutions with well chosen weight exponents $\underline{\beta} < -1$ in case $\mathbf{V} \subset \mathbf{K}_{-1}^1(\Omega)$, whereas in the general case, (3.13b) can be applied: For convenience, we write the weight exponent in the form

$$\underline{\beta} = -1 - \underline{b}, \quad \text{with} \quad \underline{b} = (b_{\mathbf{c}})_{\mathbf{c} \in \mathcal{C}}.$$

Theorem 6.1. *Let Ω be a polygon. We assume that the form a is coercive on \mathbf{V} , and that $\mathbf{V} \subset \mathbf{K}_{-1}^1(\Omega)$. There exists a positive number $b(\Omega, a, \mathbf{V})$ such that the following implication holds for any solution \mathbf{u} of the variational problem (6.3):*

$$(6.4) \quad \text{If } \forall \mathbf{c} \in \mathcal{C}, \quad 0 \leq b_{\mathbf{c}} < b(\Omega, a, \mathbf{V}) \text{ then } \mathbf{f} \in \mathbf{A}_{-\underline{b}+1}(\Omega) \implies \mathbf{u} \in \mathbf{A}_{-\underline{b}-1}(\Omega).$$

Proof. Invoking the general theory of corner problems in the variational setting, we know that there exists a maximal positive number $b(\Omega, a, \mathbf{V})$ such that

$$(6.5) \quad \text{If } \forall \mathbf{c} \in \mathcal{C}, \quad 0 \leq b_{\mathbf{c}} < b(\Omega, a, \mathbf{V}) \text{ then } \mathbf{f} \in \mathbf{K}_{-\underline{b}+1}^0(\Omega) \implies \mathbf{u} \in \mathbf{K}_{-\underline{b}-1}^2(\Omega).$$

The proof of this essentially goes back to Kondrat'ev [21], see also [9, Ch. 10] for more details on the application of Kondrat'ev's technique to variational problems. Then (6.4) is a consequence of (3.12b) applied for $\underline{\beta} = -\underline{b} - 1$, and (6.5). \square

Remark 6.2. Let $\sigma(\mathfrak{A}_{\mathbf{c}})$ denote the spectrum of the ‘‘Mellin symbol’’ $\mathfrak{A}_{\mathbf{c}}$ of the system $(L, T_{\mathbf{s}}, D_{\mathbf{s}})$ ¹ at the corner \mathbf{c} (see [21, 22]): In short, the complex number λ belongs to $\sigma(\mathfrak{A}_{\mathbf{c}})$ if there exists a non-zero function \mathbf{u} of the form $r_{\mathbf{c}}^{\lambda} \varphi(\theta_{\mathbf{c}})$ solution of the homogeneous problem (2.2) (i.e., with $\mathbf{f} = 0$) on the finite cone $\Omega_{\mathbf{c}}$. Then $b(\Omega, a, \mathbf{V})$ is the supremum of the numbers $b > 0$ such that

$$\{\lambda \in \mathbb{C} : 0 \leq \text{Re } \lambda \leq b\} \cap \sigma(\mathfrak{A}_{\mathbf{c}}) = \emptyset \quad \forall \mathbf{c} \in \mathcal{C}.$$

In (6.4) and (6.5), we have for the sake of simplicity chosen to write a common estimate for all corner weight exponents. The regularity question being local, it is clear that we could have defined a bound $b(\mathbf{c}, a, \mathbf{V})$ separately for each corner and then replaced the conditions in (6.4) and (6.5) by the inequalities $0 \leq b_{\mathbf{c}} < b(\mathbf{c}, a, \mathbf{V})$ for all corners $\mathbf{c} \in \mathcal{C}$. In this case, we can take for $b(\mathbf{c}, a, \mathbf{V})$ the smallest positive real part of the elements of $\sigma(\mathfrak{A}_{\mathbf{c}})$.

Example 6.3. Let us consider the gradient form $a = a_{\nabla}$ on scalar functions. The associated operator is the Laplacian Δ . Let $\omega_{\mathbf{c}}$ be the opening of Ω near the vertex \mathbf{c} and denote by $\Gamma_{\mathbf{c}}^i$, $i = 1, 2$, the two sides of Ω containing \mathbf{c} .

¹ $\mathfrak{A}_{\mathbf{c}}$ is also called ‘‘operator pencil’’ generated by the system $(L, T_{\mathbf{s}}, D_{\mathbf{s}})$.

(i) For the Dirichlet problem, we have $\mathbf{V} \subset \mathbf{K}_{-1}^1(\Omega)$ and

$$b(\Omega, \mathbf{a}_\nabla, H_0^1) = \min_{\mathbf{c} \in \mathcal{C}} \left\{ \frac{\pi}{\omega_{\mathbf{c}}} \right\}.$$

(ii) In the mixed Neumann-Dirichlet case, if at all corners Dirichlet conditions are imposed on at least one side containing \mathbf{c} , we still have $\mathbf{V} \subset \mathbf{K}_{-1}^1(\Omega)$ and

$$b(\Omega, \mathbf{a}_\nabla, \mathbf{V}) = \min \left\{ \min_{\mathbf{c} \in \mathcal{C}_D} \left\{ \frac{\pi}{\omega_{\mathbf{c}}} \right\}, \min_{\mathbf{c} \in \mathcal{C}_M} \left\{ \frac{\pi}{2\omega_{\mathbf{c}}} \right\} \right\},$$

where \mathcal{C}_D is the set of Dirichlet corners \mathbf{c} (Dirichlet conditions on both sides $\Gamma_{\mathbf{c}}^i$) and \mathcal{C}_M the set of ‘‘Mixed’’ corners \mathbf{c} (Dirichlet conditions on only one side $\Gamma_{\mathbf{c}}^i$).

If we do not have $\mathbf{V} \subset \mathbf{K}_{-1}^1(\Omega)$ or for more general data, it is convenient to start from a regularity result in J -weighted spaces.

Theorem 6.4. *We assume that the form \mathbf{a} is coercive on \mathbf{V} . There exists a positive number $b^*(\Omega, \mathbf{a}, \mathbf{V})$ such that the following implication holds for any solution \mathbf{u} of the variational problem (6.3):*

$$(6.6) \quad \text{If } \forall \mathbf{c} \in \mathcal{C}, \quad 0 \leq b_{\mathbf{c}} < b^*(\Omega, \mathbf{a}, \mathbf{V}) \text{ then } \mathbf{f} \in \mathbf{B}_{-b+1}(\Omega) \implies \mathbf{u} \in \mathbf{B}_{-b-1}(\Omega).$$

Proof. The proof relies on regularity results in spaces with non-homogeneous norms: By a modification of Kondrat’ev’s method, see [27, 22] and [12], one can prove that for any $m \geq 2$, there exists a maximal number $b_m \in (0, m]$ such that we have the implication

$$(6.7) \quad \text{If } \forall \mathbf{c} \in \mathcal{C}, \quad 0 \leq b_{\mathbf{c}} < b_m, \text{ then } \mathbf{f} \in \mathbf{J}_{-b+1}^{m-2}(\Omega) \implies \mathbf{u} \in \mathbf{J}_{-b-1}^m(\Omega)$$

for variational solutions. The sequence (b_m) is stationary for $m \geq m_0$ large enough, and $b^*(\Omega, \mathbf{a}, \mathbf{V})$ is given by b_{m_0} . A complete proof in this framework is presented in [9, Ch. 13]. Then (6.6) is a consequence of (3.13b), and (6.7). \square

Remark 6.5. For $b \in (k, k+1)$ (with a natural number k), formula (3.10) yields

$$\mathbf{B}_{-b-1}(\Omega_{\mathbf{c}}) = \mathbf{A}_{-b-1}(\Omega_{\mathbf{c}}) \oplus (\mathbb{P}^k)^N \quad (\mathbf{c} \in \mathcal{C}).$$

Remark 6.6. The number $b^*(\Omega, \mathbf{a}, \mathbf{V})$ can be characterized in a similar way as $b(\Omega, \mathbf{a}, \mathbf{V})$ (cf. Remark 6.2). For each corner \mathbf{c} , the spectrum $\sigma(\mathfrak{A}_{\mathbf{c}})$ has to be modified concerning its possible integer elements (condition of injectivity modulo polynomials [12, 9]). This defines a possibly slightly different set, denoted by $\sigma_*(\mathfrak{A}_{\mathbf{c}})$ and $b^*(\Omega, \mathbf{a}, \mathbf{V})$ is the supremum of the numbers $b > 0$ such that

$$\{\lambda \in \mathbb{C} : 0 < \operatorname{Re} \lambda \leq b\} \cap \sigma_*(\mathfrak{A}_{\mathbf{c}}) = \emptyset \quad \forall \mathbf{c} \in \mathcal{C}.$$

Example 6.7. Let us come back to the gradient form $\mathbf{a} = \mathbf{a}_\nabla$ on scalar functions. For any mixed Neumann-Dirichlet problem, including the pure Neumann problem, Theorem 6.4 is valid and we find

$$b^*(\Omega, \mathbf{a}_\nabla, \mathbf{V}) = \min \left\{ \min_{\mathbf{c} \in \mathcal{C}_D \cup \mathcal{C}_N} \left\{ \frac{\pi}{\omega_{\mathbf{c}}} \right\}, \min_{\mathbf{c} \in \mathcal{C}_M} \left\{ \frac{\pi}{2\omega_{\mathbf{c}}} \right\} \right\},$$

where \mathcal{C}_D is the set of Dirichlet corners, \mathcal{C}_N is the set of Neumann corners, and \mathcal{C}_M the set of ‘‘Mixed’’ corners \mathbf{c} . Thus $b^*(\Omega, \mathbf{a}_\nabla, \mathbf{V})$ will always be greater than $\frac{1}{4}$. For the pure Dirichlet or pure Neumann problem on a convex polygon, it will be greater than 1, and for some triangles even greater than 2, but never greater than 3.

Remark 6.8. Theorem 6.4 has to be compared with earlier results by Babuška and Guo²: The Laplace operator with non-homogeneous mixed boundary conditions is considered in [2, 3]; more general scalar second order operators with analytic coefficients are addressed in [1] and finally the Lamé system of linear elasticity with non-homogeneous mixed Dirichlet-Neumann boundary conditions is investigated in [14]. These results are at the same time more general than Theorem 6.4 since they address non-homogeneous boundary conditions and variable coefficients, but more restrictive since they do not include a full class of coercive second order systems with a unified approach. In section 7 we explain how our technique of proof generalizes to non-homogeneous boundary conditions and variable coefficients. Since the results so obtained are not entirely new, we try to be as concise as possible, and we will only sketch the proofs. Detailed proofs and more general results will be published in [9, Part II].

6.2. Regularity of variational solutions in polyhedra. Let Ω be a polyhedron with edges $\mathbf{e} \in \mathcal{E}$ and corners $\mathbf{c} \in \mathcal{C}$. The comparison between the variational space \mathbf{V} and weighted spaces $\mathbf{K}_{\underline{\beta}}^1(\Omega)$ and $\mathbf{J}_{\underline{\beta}}^1(\Omega)$, cf. (5.4) and (5.16), is still related with the multi-exponent $\beta_{\mathbf{c}} = \beta_{\mathbf{e}} = -1$ and essential boundary conditions: We have

$$\mathbf{J}_{-1}^1(\Omega) = \mathbf{H}^1(\Omega)$$

and, in the Dirichlet case

$$\mathbf{H}_0^1(\Omega) \subset \mathbf{K}_{-1}^1(\Omega).$$

Moreover, the intermediate space

$$\mathbf{J}_{-1}^1(\Omega; \mathcal{C}, \emptyset) = \{u \in \mathbf{H}^1(\Omega) : r_{\mathbf{c}}^{-1}u \in \mathbf{L}^2(\Omega) \quad \forall \mathbf{c} \in \mathcal{C}\},$$

also coincides with $\mathbf{H}^1(\Omega)$ by virtue of Hardy's inequality.

The analogues of Theorems 6.1 and 6.4 hold for polyhedra. For convenience, we consider multi-exponents of the form

$$\underline{\beta} = -1 - \underline{b}, \quad \text{with} \quad \underline{b} = (b_{\mathbf{c}})_{\mathbf{c} \in \mathcal{C}} \cup (b_{\mathbf{e}})_{\mathbf{e} \in \mathcal{E}}.$$

The issue is twofold:

- (1) Verify Assumptions 5.5 or 5.13, which are closed range properties
- (2) Give conditions for variational solutions to belong to spaces $\mathbf{K}_{\underline{\beta}}^1(\Omega)$ or $\mathbf{J}_{\underline{\beta}}^1(\Omega)$.

Let $\mathbf{e} \in \mathcal{E}$. Denote by $\mathcal{W}_{\mathbf{e}}$ the wedge which coincides with Ω in a neighborhood of the edge \mathbf{e} and by $\mathcal{K}_{\mathbf{e}}$ the plane sector such that $\mathcal{W}_{\mathbf{e}} \cong \mathcal{K}_{\mathbf{e}} \times \mathbb{R}$. A minimal condition for Assumptions 5.5 or 5.13 to hold is an injectivity condition for the Fourier symbol of the system $(L, T_{\mathbf{s}}, D_{\mathbf{s}})$ on the plane sector $\mathcal{K}_{\mathbf{e}}$. As a side remark, we mention that it can be shown that in the variational case, such a condition is satisfied for all $\beta_{\mathbf{e}} < -1$ with the exception of a discrete set, see [9, Part III].

As a matter of fact, the condition which ensures the regularity of variational solutions *implies* Assumptions 5.5 or 5.13. Hence we focus on conditions for the regularity. There are not so many results on regularity for elliptic boundary value problems in polyhedra. Let us quote [24, 25] for early results in general n -dimensional polyhedral domains in spaces of \mathbf{K} type, [12] in n -dimensional polyhedral domains in standard Sobolev spaces, and more

²When $b \in (0, 1)$, our space $\mathbf{B}_{-b-1}(\Omega)$ coincides with their space $B_{\beta}^2(\Omega)$ for $\beta = 1 - b$.

recently [29] in 3-dimensional polyhedral domains in spaces $J_{\frac{1}{2}}^n(\mathcal{C}, \mathcal{E}_0)$, cf. Remark 5.12 (ii).

The latter results, especially [29, Thms. 7.1 & 7.2], fit exactly to complement our results, namely in the form (5.25). For this reason we formulate the following theorem with the assumptions of [29], that is mixed Dirichlet-Neumann boundary conditions for second order systems:

$$\mathbf{V} = \{\mathbf{u} \in \mathbf{H}^1(\Omega) : \mathbf{u}|_{\Gamma_{\mathbf{s}}} = 0, \mathbf{s} \in \mathcal{S}_D\}.$$

Let \mathcal{E}_0 be the set of edges \mathbf{e} which are the sides of faces $\Gamma_{\mathbf{s}}$ with $\mathbf{s} \in \mathcal{S}_D$. We still consider sesquilinear forms (6.1).

Theorem 6.9. *We assume that the form \mathbf{a} is coercive on \mathbf{V} . There exist two positive numbers $b_{\mathcal{C}}(\Omega, \mathbf{a}, \mathbf{V})$ and $b_{\mathcal{E}}(\Omega, \mathbf{a}, \mathbf{V})$ such that the following implication holds for any solution \mathbf{u} of the variational problem (6.3):*

$$(6.8) \quad \text{If } \forall \mathbf{c} \in \mathcal{C}, \quad 0 \leq b_{\mathbf{c}} < b_{\mathcal{C}}(\Omega, \mathbf{a}, \mathbf{V}) \quad \text{and} \quad \forall \mathbf{e} \in \mathcal{E}, \quad 0 \leq b_{\mathbf{e}} < b_{\mathcal{E}}(\Omega, \mathbf{a}, \mathbf{V}) \\ \text{then } \mathbf{f} \in \mathbf{B}_{-\underline{b}+1}(\Omega; \mathcal{C}, \mathcal{E}_0) \implies \mathbf{u} \in \mathbf{B}_{-\underline{b}-1}(\Omega; \mathcal{C}, \mathcal{E}_0).$$

Proof. First Theorem 7.2 of [29] guarantees that the Assumption 5.5 is satisfied with $\beta_{\mathbf{e}} = -b_{\mathbf{e}} + 1$, with $b_{\mathbf{e}}$ satisfying (6.8). Second Theorem 7.1 of [29] show the regularity $\mathbf{u} \in \mathbf{J}_{-\underline{b}-1}^1(\Omega; \mathcal{C}, \mathcal{E}_0)$ with \underline{b} satisfying (6.8). Hence the conclusion follows from Theorem 5.14 (see Remark 5.15). \square

Remark 6.10. Let $\sigma(\mathfrak{A}_{\mathbf{c}})$ and $\sigma(\mathfrak{A}_{\mathbf{e}})$ denote the spectrum of the Mellin symbol $\mathfrak{A}_{\mathbf{c}}$ and $\mathfrak{A}_{\mathbf{e}}$ of the system $(L, T_{\mathbf{s}}, D_{\mathbf{s}})$ at the corner \mathbf{c} and the edge \mathbf{e} , respectively. Then $b_{\mathcal{E}}(\Omega, \mathbf{a}, \mathbf{V})$ is the supremum of the numbers $b > 0$ such that

$$\{\lambda \in \mathbb{C} : 0 \leq \operatorname{Re} \lambda \leq b\} \cap \sigma(\mathfrak{A}_{\mathbf{e}}) = \emptyset \quad \forall \mathbf{e} \in \mathcal{E},$$

and $b_{\mathcal{C}}(\Omega, \mathbf{a}, \mathbf{V})$ is the supremum of the numbers $b > 0$ such that

$$\{\lambda \in \mathbb{C} : -\frac{1}{2} \leq \operatorname{Re} \lambda \leq b - \frac{1}{2}\} \cap \sigma(\mathfrak{A}_{\mathbf{c}}) = \emptyset \quad \forall \mathbf{c} \in \mathcal{C}.$$

Remark 6.11. Let us define $b_{\mathcal{C}}^*(\Omega, \mathbf{a}, \mathbf{V})$ as the supremum of positive b such that for all λ , $-\frac{1}{2} \leq \operatorname{Re} \lambda \leq b - \frac{1}{2}$, the condition of injectivity modulo polynomials is satisfied at the corner \mathbf{c} . Then replacing $b_{\mathcal{C}}(\Omega, \mathbf{a}, \mathbf{V})$ by $b_{\mathcal{C}}^*(\Omega, \mathbf{a}, \mathbf{V})$, we obtain the condition which ensures the analytic regularity in the maximal classes $\mathbf{B}_{-\underline{b}-1}(\Omega) = \mathbf{B}_{-\underline{b}-1}(\Omega; \emptyset, \emptyset)$ cf. Definition 5.11.

7. GENERALIZATION TO NON-HOMOGENEOUS BOUNDARY DATA AND VARIABLE COEFFICIENTS

The fundamental estimate (1.1) in the smooth case allows non-homogeneous boundary data and variable coefficients, and the analytic regularity results can therefore be extended to cover this more general situation. But the difficulty to do so is of a quite different level for two-dimensional and for three-dimensional domains (due to the anisotropy in the latter case). Here we mainly address two-dimensional domains and give only some orientations for the treatment of three-dimensional domains at the end of this section.

So, let us consider the general boundary value problem, set on the polygon Ω :

$$(7.1) \quad \begin{cases} L \mathbf{u} = \mathbf{f} & \text{in } \Omega, \\ T_{\mathbf{s}} \mathbf{u} = \mathbf{g}_{\mathbf{s}} & \text{on } \Gamma_{\mathbf{s}}, \quad \mathbf{s} \in \mathcal{S}, \\ D_{\mathbf{s}} \mathbf{u} = \mathbf{h}_{\mathbf{s}} & \text{on } \Gamma_{\mathbf{s}}, \quad \mathbf{s} \in \mathcal{S}, \end{cases}$$

where the operators $L = L(\mathbf{x}; \partial_{\mathbf{x}})$, $T_{\mathbf{s}} = T_{\mathbf{s}}(\mathbf{x}; \partial_{\mathbf{x}})$ and $D_{\mathbf{s}} = D_{\mathbf{s}}(\mathbf{x})$ may have variable coefficients and lower order terms.

7.1. Trace spaces. First, we have to introduce the trace spaces of $\mathcal{K}_{\beta}^m(\Omega)$ and $\mathcal{A}_{\beta}(\Omega)$ on each side $\Gamma_{\mathbf{s}}$ of Ω . Let us choose a side \mathbf{s} and denote by \mathbf{c} and \mathbf{c}' its two ends. We consider a covering of $\Gamma_{\mathbf{s}}$ by two open segments Γ and Γ' so that

$$\mathbf{c} \in \bar{\Gamma}, \quad \mathbf{c}' \notin \bar{\Gamma} \quad \text{and} \quad \mathbf{c}' \in \bar{\Gamma}', \quad \mathbf{c} \notin \bar{\Gamma}'.$$

We note that we can take $r := r_{\mathbf{c}}$ as the tangential variable along Γ . For $k \in \mathbb{N}$, $\sigma \in (0, 1)$ and $\gamma \in \mathbb{R}$ we define the weighted space $\mathcal{K}_{\gamma}^{k+\sigma}(\Gamma)$ by

$$\mathcal{K}_{\gamma}^{k+\sigma}(\Gamma) = \{g \in \mathcal{K}_{\gamma}^k(\Gamma) : |r^{\gamma+k+\sigma} \partial_r^k g|_{\sigma, \Gamma} < \infty\},$$

where the Sobolev-Slobodeckii semi-norm $|\cdot|_{\sigma, \Gamma}$ is defined by

$$|v|_{\sigma, \Gamma}^2 = \int_{\Gamma} \int_{\Gamma} \frac{|v(r) - v(\tilde{r})|^2}{|r - \tilde{r}|^{1+2\sigma}} dr d\tilde{r}.$$

For $\gamma' \in \mathbb{R}$, we define similarly $\mathcal{K}_{\gamma'}^{k+\sigma}(\Gamma')$ using now the powers of $r_{\mathbf{c}'}$ as weight. For $\underline{\gamma} = (\gamma, \gamma')$ we define the following global weighted space on the side $\Gamma_{\mathbf{s}}$

$$\mathcal{K}_{\underline{\gamma}}^{k+\sigma}(\Gamma_{\mathbf{s}}) = \{g \in L_{\text{loc}}^2(\Gamma_{\mathbf{s}}) : g|_{\Gamma} \in \mathcal{K}_{\gamma}^{k+\sigma}(\Gamma), g|_{\Gamma'} \in \mathcal{K}_{\gamma'}^{k+\sigma}(\Gamma')\}.$$

Then (see e.g. [22, § 6.1.1]), for any multi-exponent $\underline{\beta} = (\beta_{\mathbf{c}})_{\mathbf{c} \in \mathcal{C}}$,

$$\mathcal{K}_{\underline{\beta}+1/2}^{m-1/2}(\Gamma_{\mathbf{s}}) \quad \text{is the trace space of } \mathcal{K}_{\underline{\beta}}^m(\Omega) \quad \text{on } \Gamma_{\mathbf{s}}.$$

Here, of course, we understand that we take the weight exponents $\beta_{\mathbf{c}} + \frac{1}{2}$ and $\beta_{\mathbf{c}'} + \frac{1}{2}$ at the two ends \mathbf{c} and \mathbf{c}' of $\Gamma_{\mathbf{s}}$.

The analytic classes $\mathcal{A}_{\gamma}(\Gamma)$, $\mathcal{A}_{\gamma'}(\Gamma')$, and $\mathcal{A}_{\underline{\gamma}}(\Gamma_{\mathbf{s}})$ are defined accordingly:

$$\mathcal{A}_{\gamma}(\Gamma) = \left\{ g \in \bigcap_{m \geq 0} \mathcal{K}_{\gamma}^m(\Gamma) : \exists C > 0, \forall m \in \mathbb{N}, \quad \|r^{\gamma+m} \partial_r^m g\|_{\Gamma} \leq C^{m+1} m! \right\},$$

– we recall that $\|\cdot\|_{\Gamma}$ is the $L^2(\Gamma)$ -norm, and

$$\mathcal{A}_{\underline{\gamma}}(\Gamma_{\mathbf{s}}) = \{g \in L_{\text{loc}}^2(\Gamma_{\mathbf{s}}) : g|_{\Gamma} \in \mathcal{A}_{\gamma}(\Gamma), g|_{\Gamma'} \in \mathcal{A}_{\gamma'}(\Gamma')\}.$$

The trace spaces of J-weighted spaces can be defined similarly, see the discussion in [8, Rem. 3.20] and [9, Ch. 11]. Let us just give the definition of the corresponding analytic class, locally

$$\mathcal{B}_{\gamma}(\Gamma) = \left\{ g \in \bigcap_{m > -\gamma - \frac{1}{2}} \mathcal{J}_{\gamma}^m(\Gamma) : \exists C > 0, \forall m > -\gamma - \frac{1}{2}, \quad \|r^{\gamma+m} \partial_r^m g\|_{\Gamma} \leq C^{m+1} m! \right\},$$

where $J_\gamma^m(\Gamma) = \{g \in L_{\text{loc}}^2(\Gamma) : r^{\gamma+m} \partial_r^j g \in L^2(\Gamma), j = 0, \dots, m\}$. Globally we set

$$B_{\underline{\gamma}}(\Gamma_s) = \{g \in L_{\text{loc}}^2(\Gamma_s) : g|_{\Gamma} \in B_\gamma(\Gamma), g|_{\Gamma'} \in B_{\gamma'}(\Gamma')\}.$$

7.2. Weighted spaces with homogeneous norms. We give now the generalization of the first part of Theorem 3.4 to non-homogeneous boundary conditions and variable coefficients.

Theorem 7.1. *We assume that L , T_s and D_s have analytic coefficients over $\overline{\Omega}$ and $\overline{\Gamma_s}$ (L and T_s may have lower order terms), and that $\{T_s, D_s\}$ cover L at each point in $\overline{\Gamma_s}$ (denote by N_s the number of Dirichlet conditions). Let $\underline{\beta}$ be a weight multi-exponent. Let $\mathbf{u} \in \mathbf{H}_{\text{loc}}^2(\overline{\Omega} \setminus \mathcal{C})$ be a solution of problem (7.1) with*

$$(7.2a) \quad \mathbf{f} \in \mathbf{K}_{\underline{\beta}+2}^n(\Omega), \quad \mathbf{g}_s \in \mathbf{K}_{\underline{\beta}+3/2}^{n+1/2}(\Gamma_s)^{N-N_s}, \quad \text{and} \quad \mathbf{h}_s \in \mathbf{K}_{\underline{\beta}+1/2}^{n+3/2}(\Gamma_s)^{N_s} \quad (n \in \mathbb{N}).$$

Then the following implication holds

$$(7.2b) \quad \mathbf{u} \in \mathbf{K}_{\underline{\beta}}^1(\Omega) \quad \implies \quad \mathbf{u} \in \mathbf{K}_{\underline{\beta}}^{n+2}(\Omega).$$

Likewise, if

$$(7.3a) \quad \mathbf{f} \in \mathbf{A}_{\underline{\beta}+2}(\Omega), \quad \mathbf{g}_s \in \mathbf{A}_{\underline{\beta}+3/2}(\Gamma_s)^{N-N_s}, \quad \text{and} \quad \mathbf{h}_s \in \mathbf{A}_{\underline{\beta}+1/2}(\Gamma_s)^{N_s}$$

then the following implication holds

$$(7.3b) \quad \mathbf{u} \in \mathbf{K}_{\underline{\beta}}^1(\Omega) \quad \implies \quad \mathbf{u} \in \mathbf{A}_{\underline{\beta}}(\Omega).$$

Proof. (Sketch) We will prove local estimates with analytic control of derivatives near each corner. Pick up a corner \mathbf{c} . We set $\beta := \beta_{\mathbf{c}}$. We can assume without restriction that $\mathbf{c} = \mathbf{0}$ and $\Omega_{\mathbf{c}} = \Omega \cap \mathcal{B}(\mathbf{0}, 1)$.

(i) Case of homogeneous operators with constant coefficients. The idea of the proof is the same as in the ‘‘simple case’’ when $\mathbf{g} = 0$ and $\mathbf{h} = 0$ (Theorem 2.2): We start from reference estimate (1.1) on the domains $\widehat{\mathcal{V}}$ and $\widehat{\mathcal{V}}'$ defined in (2.7):

$$(7.4) \quad \frac{1}{k!} |\widehat{\mathbf{u}}|_{k; \widehat{\mathcal{V}}} \leq A^{k+1} \left\{ \sum_{\ell=0}^{k-2} \frac{1}{\ell!} \left(|\widehat{\mathbf{f}}|_{\ell; \widehat{\mathcal{V}}} + \sum_{\mathbf{s}=1}^2 \left(\|\widehat{\mathbf{g}}_{\mathbf{s}}\|_{\ell+\frac{1}{2}; \widehat{\Gamma}'_{\mathbf{s}}} + \|\widehat{\mathbf{h}}_{\mathbf{s}}\|_{\ell+\frac{3}{2}; \widehat{\Gamma}'_{\mathbf{s}}} \right) \right) + \|\widehat{\mathbf{u}}\|_{1; \widehat{\mathcal{V}}} \right\}.$$

with

$$(7.5) \quad \widehat{\mathbf{f}} := L\widehat{\mathbf{u}}, \quad \widehat{\mathbf{g}}_{\mathbf{s}} := T_{\mathbf{s}}\widehat{\mathbf{u}}, \quad \text{and} \quad \widehat{\mathbf{h}}_{\mathbf{s}} := D_{\mathbf{s}}\widehat{\mathbf{u}}.$$

Here $\Gamma_{\mathbf{s}}$, $\mathbf{s} = 1, 2$ are the two sides of Ω near the vertex $\mathbf{c} = \mathbf{0}$, and

$$\widehat{\Gamma}'_{\mathbf{s}} = \partial\widehat{\mathcal{V}}' \cap \Gamma_{\mathbf{s}}.$$

Then we split $\|\widehat{\mathbf{g}}_{\mathbf{s}}\|_{\ell+\frac{1}{2}; \widehat{\Gamma}'_{\mathbf{s}}}$ and $\|\widehat{\mathbf{h}}_{\mathbf{s}}\|_{\ell+\frac{3}{2}; \widehat{\Gamma}'_{\mathbf{s}}}$ into homogeneous components and insert weights like in (2.10). We then perform the change of variables $\widehat{\mathbf{x}} \mapsto \mathbf{x} = 2^{-\mu}\widehat{\mathbf{x}}$ for any $\mu \in \mathbb{N}$. Defining $\widehat{\mathbf{u}}(\widehat{\mathbf{x}}) := \mathbf{u}(\mathbf{x})$ we have

$$(7.6) \quad \widehat{\mathbf{f}}(\widehat{\mathbf{x}}) = 2^{-2\mu}\mathbf{f}(\mathbf{x}), \quad \widehat{\mathbf{g}}_{\mathbf{s}}(\widehat{\mathbf{x}}) = 2^{-\mu}\mathbf{g}_{\mathbf{s}}(\mathbf{x}), \quad \text{and} \quad \widehat{\mathbf{h}}_{\mathbf{s}}(\widehat{\mathbf{x}}) = \mathbf{h}_{\mathbf{s}}(\mathbf{x}).$$

Like in the proof of Theorem 2.2, we find the common factor $2^{\mu(\beta-1)}$ on every term. We multiply the resulting inequalities by $2^{-\mu(\beta-1)}$, take squares and sum over $\mu \in \mathbb{N}$ to find finally

$$(7.7) \quad \frac{1}{k!} \|r^{\beta+|\alpha|} \partial_{\mathbf{x}}^{\alpha} \mathbf{u}\|_{\Omega_c} \leq A^{k+1} \left\{ \sum_{\ell=0}^{k-2} \frac{1}{\ell!} \left(\|r^{\beta+2+|\alpha|} \partial_{\mathbf{x}}^{\alpha} \mathbf{f}\|_{\Omega'_c} + \sum_{\mathbf{s}=1}^2 \left(\|\mathbf{g}_{\mathbf{s}}\|_{K_{\beta+3/2}^{\ell+1/2}(\Gamma'_s)} + \|\mathbf{h}_{\mathbf{s}}\|_{K_{\beta+1/2}^{\ell+3/2}(\Gamma'_s)} \right) \right) + \|\mathbf{u}\|_{K_{\beta}^1(\Omega'_c)} \right\}$$

with $\Gamma'_s = \partial\Omega_c \cap \Gamma_s$.

(ii) Case of non-homogeneous operators with variable coefficients: Now

$$L = L(\mathbf{x}; \partial_{\mathbf{x}}), \quad T_{\mathbf{s}} = T_{\mathbf{s}}(\mathbf{x}; \partial_{\mathbf{x}}) \quad \text{and} \quad D_{\mathbf{s}} = D_{\mathbf{s}}(\mathbf{x}).$$

We perform the same dyadic partition and for each $\mu \in \mathbb{N}$, the same changes of variables $\widehat{\mathbf{x}} \mapsto \mathbf{x} = 2^{-\mu} \widehat{\mathbf{x}}$. Defining $\widehat{\mathbf{u}}(\widehat{\mathbf{x}}) := \mathbf{u}(\mathbf{x})$ we still have (7.6) with, instead of (7.5):

$$\begin{aligned} \widehat{\mathbf{f}} &:= L^{\mu} \widehat{\mathbf{u}}, \quad \widehat{\mathbf{g}}_{\mathbf{s}} := T_{\mathbf{s}}^{\mu} \widehat{\mathbf{u}}, \quad \text{and} \quad \widehat{\mathbf{h}}_{\mathbf{s}} := D_{\mathbf{s}}^{\mu} \widehat{\mathbf{u}} \quad \text{with} \\ L^{\mu} &:= 2^{-2\mu} L(2^{-\mu} \widehat{\mathbf{x}}, 2^{\mu} \partial_{\widehat{\mathbf{x}}}), \quad T_{\mathbf{s}}^{\mu} := 2^{-\mu} T_{\mathbf{s}}(2^{-\mu} \widehat{\mathbf{x}}, 2^{\mu} \partial_{\widehat{\mathbf{x}}}), \quad \text{and} \quad D_{\mathbf{s}}^{\mu} := D_{\mathbf{s}}(2^{-\mu} \widehat{\mathbf{x}}). \end{aligned}$$

We note that when $\mu \rightarrow \infty$, the operators L^{μ} and $T_{\mathbf{s}}^{\mu}$ tend to the principal parts \underline{L} and $\underline{T}_{\mathbf{s}}$ of L and $T_{\mathbf{s}}$ frozen at $\mathbf{0}$ respectively, and $D_{\mathbf{s}}^{\mu}$ tends to $D_{\mathbf{s}}(\mathbf{0}) =: \underline{D}_{\mathbf{s}}$. As a consequence of the ellipticity and covering properties of the boundary value system $(\underline{L}, \underline{T}_{\mathbf{s}}, \underline{D}_{\mathbf{s}})$ and the analyticity of coefficients, estimates (7.4) holds with one and the same constant A when μ is large enough. For the finitely many remaining values of μ , we use the ellipticity of $(L^{\mu}, T_{\mathbf{s}}^{\mu}, D_{\mathbf{s}}^{\mu})$ and the analyticity of its coefficients. As a result, we find a possibly larger constant A for which (7.4) holds for every $\mu \in \mathbb{N}$. Then we insert the weights, scale and sum with respect to μ as in the proof of Theorem 2.2, and we deduce that (7.7) still holds in the case of variable coefficients and lower order terms.

(iii) With the local estimates (7.7) at hands in all cases, we finish the proof of the analytic shift result as before for Theorem 3.4. \square

More details about the arguments of this proof can be found in [9]: In [10, Ch. 2] for the local estimate (7.4) in smooth domains with general data on the boundary and variable coefficients, in [9, Ch. 6] for model problems in cones with general data on the boundary, and in [9, Ch. 7] for variable coefficients in general corner domains.

Since Kondrat'ev's results [21] apply to general operators with variable coefficients, Theorem 6.1 can be generalized to coercive problems with analytic coefficients.

7.3. Weighted spaces with non-homogeneous norms. The generalization to non-zero boundary conditions goes through similarly with weighted spaces \mathcal{J} and analytic classes \mathcal{B} . However, the consideration of lower order terms and variable coefficients requires the modification of some of the estimates. For the sake of simplicity, let us consider a local

model problem as in (2.2)

$$(7.8) \quad \begin{cases} L \mathbf{u} = \mathbf{f} & \text{in } \mathcal{K} \cap \mathcal{W}', \\ T_i \mathbf{u} = 0 & \text{on } \Gamma_i \cap \overline{\mathcal{W}'}, \quad i = 1, 2, \\ D_i \mathbf{u} = 0 & \text{on } \Gamma_i \cap \overline{\mathcal{W}'}, \quad i = 1, 2, \end{cases}$$

where $L = L(\mathbf{x}; \partial_{\mathbf{x}})$ is a second order elliptic system with analytic coefficients on $\overline{\mathcal{W}'}$. We assume for simplicity that the boundary operators T_i and D_i are homogeneous with constant coefficients. We assume that for $i = 1, 2$ and for each point $\mathbf{x}_0 \in \overline{\Gamma}_i \cap \overline{\mathcal{W}'}$ the system $L(\mathbf{x}_0; \partial_{\mathbf{x}})$ frozen at \mathbf{x}_0 is covered by the boundary operators (T_i, D_i) . As a consequence of the proof above, Theorem 2.2 generalizes: We have the estimate

$$(7.9) \quad \frac{1}{k!} \left(\sum_{|\alpha|=k} \|r^{\beta+|\alpha|} \partial_{\mathbf{x}}^{\alpha} \mathbf{u}\|_{0; \mathcal{W}}^2 \right)^{\frac{1}{2}} \leq C^{k+1} \left\{ \sum_{\ell=0}^{k-2} \frac{1}{\ell!} \left(\sum_{|\alpha|=\ell} \|r^{\beta+2+|\alpha|} \partial_{\mathbf{x}}^{\alpha} L \mathbf{u}\|_{0; \mathcal{W}'}^2 \right)^{\frac{1}{2}} + \sum_{|\alpha| \leq 1} \|r^{\beta+|\alpha|} \partial_{\mathbf{x}}^{\alpha} \mathbf{u}\|_{0; \mathcal{W}'} \right\}.$$

Now the question is whether it is possible to generalize in the same way Theorem 2.6 on non-homogeneous weighted norms in this new framework of variable analytic coefficients. The correct answer is that we have to modify estimate (2.15):

Proposition 7.2. *With the above assumptions on L , any solution of the boundary value problem (7.8) Let $\beta > -2$ be a real number. Let $\mathbf{u} \in \mathbf{J}_{\beta}^1(\mathcal{W}')$ be a solution of problem (7.8). Then there exists a constant $C \geq 1$ independent of \mathbf{u} such that for all integer $k \geq 2$,*

$$(7.10) \quad \frac{1}{k!} \left(\sum_{|\alpha|=k} \|r^{\beta+|\alpha|} \partial_{\mathbf{x}}^{\alpha} \mathbf{u}\|_{0; \mathcal{W}}^2 \right)^{\frac{1}{2}} \leq C^{k+1} \left\{ \sum_{\ell=0}^{k-2} \frac{1}{\ell!} \left(\sum_{|\alpha|=\ell} \|r^{\beta+2+|\alpha|} \partial_{\mathbf{x}}^{\alpha} L \mathbf{u}\|_{0; \mathcal{W}'}^2 \right)^{\frac{1}{2}} + \sum_{|\alpha| \leq 1} \|r^{\beta+|\alpha|} \partial_{\mathbf{x}}^{\alpha} \mathbf{u}\|_{0; \mathcal{W}'} \right\}.$$

Remark 7.3. The last term in the right hand side is nothing but $\|\mathbf{u}\|_{\mathbf{J}_{\beta}^1(\mathcal{W}')}$. Estimates (7.9), (7.10) and (2.15) (for $m = 1$) are very close to each other. The main groups of terms with factorial coefficients are identical. The difference is born by the \mathbf{L}^2 weighted norm of \mathbf{u} in the right-hand side: In (7.9), this term is $\|r^{\beta} \mathbf{u}\|_{0; \mathcal{W}'}$, in (2.15) for $m = 1$, it is absent, and in (7.10), it is equal to $\|r^{\beta+1} \mathbf{u}\|_{0; \mathcal{W}'}$. In applications to variational problems in \mathbf{H}^1 , this makes an important difference, since for $\beta = -1 - b$ with $b \in (0, 1)$, any function $\mathbf{u} \in \mathbf{H}^1(\mathcal{W}')$ satisfies $\|r^{\beta+1} \mathbf{u}\|_{0; \mathcal{W}'} < \infty$, but not $\|r^{\beta} \mathbf{u}\|_{0; \mathcal{W}'} < \infty$ in general.

Proof. Let us introduce an intermediate domain \mathcal{W}''

$$\mathcal{W} \subset \mathcal{W}'' \subset \mathcal{W}'.$$

We first note that $\mathbf{J}_\beta^1(\mathcal{W}') \subset \mathbf{K}_{\beta+1}^1(\mathcal{W}')$ and that we can use the estimate in homogeneous norms (7.9) with $\beta + 1$:

$$(7.11) \quad \frac{1}{k!} \left(\sum_{|\alpha|=k} \|r^{\beta+1+|\alpha|} \partial_{\mathbf{x}}^\alpha \mathbf{u}\|_{0; \mathcal{W}}^2 \right)^{\frac{1}{2}} \leq C^{k+1} \left\{ \sum_{\ell=0}^{k-2} \frac{1}{\ell!} \left(\sum_{|\alpha|=\ell} \|r^{\beta+1+2+|\alpha|} \partial_{\mathbf{x}}^\alpha L\mathbf{u}\|_{0; \mathcal{W}''}^2 \right)^{\frac{1}{2}} + \sum_{|\alpha| \leq 1} \|r^{\beta+1+|\alpha|} \partial_{\mathbf{x}}^\alpha \mathbf{u}\|_{0; \mathcal{W}''} \right\}.$$

Let us recall that \underline{L} denotes the principal part of L frozen at $\mathbf{0}$. Using the analyticity of the coefficients of L we can prove that there holds

$$(7.12) \quad \frac{1}{\ell!} \left(\sum_{|\alpha|=\ell} \|r^{\beta+2+|\alpha|} \partial_{\mathbf{x}}^\alpha (L\mathbf{u} - \underline{L}\mathbf{u})\|_{0; \mathcal{W}''}^2 \right)^{\frac{1}{2}} \leq B^{\ell+1} \sum_{k=0}^{\ell+2} \frac{1}{k!} \left(\sum_{|\alpha|=k} \|r^{\beta+1+|\alpha|} \partial_{\mathbf{x}}^\alpha \mathbf{u}\|_{0; \mathcal{W}''}^2 \right)^{\frac{1}{2}}.$$

Then we use estimate (2.15) in *non-homogeneous* norm for the operator \underline{L} with $m = 1$

$$(7.13) \quad \frac{1}{k!} \left(\sum_{|\alpha|=k} \|r^{\beta+|\alpha|} \partial_{\mathbf{x}}^\alpha \mathbf{u}\|_{0; \mathcal{W}''}^2 \right)^{\frac{1}{2}} \leq C^{k+1} \left\{ \sum_{\ell=0}^{k-2} \frac{1}{\ell!} \left(\sum_{|\alpha|=\ell} \|r^{\beta+2+|\alpha|} \partial_{\mathbf{x}}^\alpha \underline{L}\mathbf{u}\|_{0; \mathcal{W}'}^2 \right)^{\frac{1}{2}} + \sum_{|\alpha|=1} \|r^{\beta+|\alpha|} \partial_{\mathbf{x}}^\alpha \mathbf{u}\|_{0; \mathcal{W}'} \right\}.$$

Using the straightforward inequality

$$\sum_{|\alpha| \leq 1} \|r^{\beta+1+|\alpha|} \partial_{\mathbf{x}}^\alpha \mathbf{u}\|_{0; \mathcal{W}''} + \sum_{|\alpha|=1} \|r^{\beta+|\alpha|} \partial_{\mathbf{x}}^\alpha \mathbf{u}\|_{0; \mathcal{W}'} \leq c \sum_{|\alpha| \leq 1} \|r^{\beta+1} \partial_{\mathbf{x}}^\alpha \mathbf{u}\|_{0; \mathcal{W}'}$$

together with a triangular inequality on $L\mathbf{u} = \underline{L}\mathbf{u} + (L\mathbf{u} - \underline{L}\mathbf{u})$, we deduce (7.10) from (7.11)–(7.13), with a new constant C independent of k . This ends the proof. \square

Remark 7.4. Proposition 7.2 admits a natural generalization, which can be proved in a similar way: If $m \geq 1$ is an integer and β is a real number such that $\beta + m > -1$, any solution $\mathbf{u} \in \mathbf{J}_\beta^m(\mathcal{W}')$ of problem (7.8) satisfies the estimates for all integer $k \geq m + 1$,

$$(7.14) \quad \frac{1}{k!} \left(\sum_{|\alpha|=k} \|r^{\beta+|\alpha|} \partial_{\mathbf{x}}^\alpha \mathbf{u}\|_{0; \mathcal{W}}^2 \right)^{\frac{1}{2}} \leq C^{k+1} \left\{ \sum_{\ell=m-1}^{k-2} \frac{1}{\ell!} \left(\sum_{|\alpha|=\ell} \|r^{\beta+2+|\alpha|} \partial_{\mathbf{x}}^\alpha L\mathbf{u}\|_{0; \mathcal{W}'}^2 \right)^{\frac{1}{2}} + \|L\mathbf{u}\|_{\mathbf{J}_{\beta+2}^{m-2}(\mathcal{W}')} + \|\mathbf{u}\|_{\mathbf{J}_\beta^m(\mathcal{W}')} \right\}.$$

To end this subsection, let us briefly indicate how things work for variational solutions. Theorem 6.4 can be extended to more general variational problems with variable coefficients and non-zero boundary data

$$(7.15) \quad \text{Find } \mathbf{u} \in \mathbf{V} \text{ such that } \forall \mathbf{v} \in \mathbf{V}, \quad a(\mathbf{u}, \mathbf{v}) = \int_{\Omega} \mathbf{f} \bar{\mathbf{v}} \, d\mathbf{x} + \sum_{\mathbf{s} \in \mathcal{S}} \int_{\Gamma_{\mathbf{s}}} \mathbf{g}_{\mathbf{s}} \bar{\mathbf{v}} \, d\tau.$$

Theorem 7.5. *Let a be a sesquilinear form of degree 1 with analytic coefficients on $\bar{\Omega}$, coercive on the space \mathbf{V} defined by the Dirichlet conditions $D_{\mathbf{s}}\mathbf{u} = 0$ on $\Gamma_{\mathbf{s}}$, for all $\mathbf{s} \in \mathcal{S}$. There exists a positive number $b_1(\Omega, \mathbf{a}, \mathbf{V}) \leq 1$ such that the following implication holds for any solution $\mathbf{u} \in \mathbf{V}$ of the variational problem (7.15) and any b , $0 < b < b_1(\Omega, \mathbf{a}, \mathbf{V})$:*

$$(7.16) \quad \mathbf{f} \in \mathbf{B}_{-b+1}(\Omega) \text{ and } \mathbf{g}_{\mathbf{s}} \in \mathbf{B}_{-b+1/2}(\Gamma_{\mathbf{s}})^{N-N_{\mathbf{s}}} \implies \mathbf{u} \in \mathbf{B}_{-b-1}(\Omega).$$

We refer to [9, Ch. 13 & 14] for more results and proofs.

7.4. Three-dimensional problems. Whereas the consideration of non-zero boundary data can be performed in three-dimensional polyhedral domains using similar tools as for zero boundary data, the consideration of variable coefficients is more delicate. There are two situations:

- (1) If coefficients are *constant in the direction of each edge* (but possibly variable in the transverse direction) the estimates (7.9) and (7.10) can be extended to edge neighborhoods, and anisotropic estimates can be proved, based on the same assumptions as in section 4. This implies in particular the generalization of the results of sections 4 and 5 to problems with *constant coefficients* (not necessarily homogeneous) in polyhedra. This also implies the generalization to *axisymmetric problems*.
- (2) If coefficients are not constant in the direction of edges, the level of difficulty increases. One would need to go back to the primitive technique of estimating commutators, cf. [9, Lemmas 1.6.2 & 2.6.2], which leads to the introduction of norms of Sobolev-Morrey type.

8. GENERALIZATION TO OTHER OPERATORS AND SYSTEMS

First we may easily extend the results of this paper to transmission problems, namely problem like (5.3) where L has piecewise constant coefficients (hence some transmission conditions have to be imposed at the common boundary of the sub-domains). Indeed an estimate like (1.1) holds for such problems and is proved in [9, Theorem 5.2.2]. Second higher order differential operators like Δ^2 may be treated in a similar manner. Finally our method may be used for the Stokes system (see [17] for two-dimensional results). Note that the Maxwell system is more delicate: Whereas in *convex* polygons or polyhedra the natural variational space is contained in \mathbf{H}^1 and all our results apply, the presence of *non-convex corners or edges* induces the appearance of non- \mathbf{H}^1 fields which require a specific treatment, see [11] in dimension two.

REFERENCES

- [1] I. BABUŠKA, B. GUO. The h - p version of the finite element method for domains with curved boundaries. *SIAM J. Numer. Anal.* **25**(4) (1988) 837–861.
- [2] I. BABUŠKA, B. GUO. Regularity of the solution of elliptic problems with piecewise analytic data. I. Boundary value problems for linear elliptic equation of second order. *SIAM J. Math. Anal.* **19**(1) (1988) 172–203.
- [3] I. BABUŠKA, B. GUO. Regularity of the solution of elliptic problems with piecewise analytic data. II. The trace spaces and application to the boundary value problems with nonhomogeneous boundary conditions. *SIAM J. Math. Anal.* **20**(4) (1989) 763–781.
- [4] P. BOLLEY, J. CAMUS, M. DAUGE. Régularité Gevrey pour le problème de Dirichlet dans des domaines à singularités coniques. *Comm. Partial Differential Equations* **10** (2) (1985) 391–432.
- [5] J. H. BRAMBLE, S. R. HILBERT. Estimation of linear functionals on Sobolev spaces with application to Fourier transforms and spline interpolation. *SIAM J. Numer. Anal.* **7** (1970) 112–124.
- [6] A. BUFFA, M. COSTABEL, M. DAUGE. Anisotropic regularity results for Laplace and Maxwell operators in a polyhedron. *C. R. Acad. Sc. Paris, Série I* **336** (2003) 565–570.
- [7] A. BUFFA, M. COSTABEL, M. DAUGE. Algebraic convergence for anisotropic edge elements in polyhedral domains. *Numer. Math.* **101** (2005) 29–65.
- [8] M. COSTABEL, M. DAUGE, S. NICAISE. Mellin analysis of weighted Sobolev spaces with nonhomogeneous norms on cones. In *Around the Research of Vladimir Maz'ya, I*, volume 11 of *International Mathematical Series*, pages 105–136. Springer and “Tamara Rozhkovskaya Publisher”, Novosibirsk 2010.
- [9] M. COSTABEL, M. DAUGE, S. NICAISE. *Corner Singularities and Analytic Regularity for Linear Elliptic Systems*. Book in preparation.
- [10] M. COSTABEL, M. DAUGE, S. NICAISE. *Corner Singularities and Analytic Regularity for Linear Elliptic Systems. Part I: Smooth domains*. <http://hal.archives-ouvertes.fr/hal-00453934/en/> Online version of Chapters 1 to 5. (2010).
- [11] M. COSTABEL, M. DAUGE, C. SCHWAB. Exponential convergence of hp -FEM for Maxwell's equations with weighted regularization in polygonal domains. *Math. Models Methods Appl. Sci.* **15**(4) (2005) 575–622.
- [12] M. DAUGE. *Elliptic Boundary Value Problems in Corner Domains – Smoothness and Asymptotics of Solutions*. Lecture Notes in Mathematics, Vol. 1341. Springer-Verlag, Berlin 1988.
- [13] B. GUO. The h - p version of the finite element method for solving boundary value problems in polyhedral domains. In M. COSTABEL, M. DAUGE, S. NICAISE, editors, *Boundary value problems and integral equations in nonsmooth domains (Luminy, 1993)*, pages 101–120. Dekker, New York 1995.
- [14] B. GUO, I. BABUŠKA. On the regularity of elasticity problems with piecewise analytic data. *Adv. in Appl. Math.* **14**(3) (1993) 307–347.
- [15] B. GUO, I. BABUŠKA. Regularity of the solutions for elliptic problems on nonsmooth domains in \mathbf{R}^3 . I. Countably normed spaces on polyhedral domains. *Proc. Roy. Soc. Edinburgh Sect. A* **127**(1) (1997) 77–126.
- [16] B. GUO, I. BABUŠKA. Regularity of the solutions for elliptic problems on nonsmooth domains in \mathbf{R}^3 . II. Regularity in neighbourhoods of edges. *Proc. Roy. Soc. Edinburgh Sect. A* **127**(3) (1997) 517–545.
- [17] B. GUO, C. SCHWAB. Analytic regularity of Stokes flow on polygonal domains in countably weighted Sobolev spaces. *J. Comput. Appl. Math.* **190**(1-2) (2006) 487–519.
- [18] B. GUO, E. P. STEPHAN. The h - p version of the coupling of finite element and boundary element methods for transmission problems in polyhedral domains. *Numer. Math.* **80**(1) (1998) 87–107.
- [19] H. HOLM, M. MAISCHAK, E. P. STEPHAN. Exponential convergence of the h - p version BEM for mixed boundary value problems on polyhedrons. *Math. Methods Appl. Sci.* **31**(17) (2008) 2069–2093.
- [20] B. KAWOHL. On nonlinear mixed boundary value problems for second order elliptic differential equations on domains with corners. *Proc. Roy. Soc. Edinburgh Sect. A* **87**(1-2) (1980/81) 35–51.
- [21] V. A. KONDRAT'EV. Boundary-value problems for elliptic equations in domains with conical or angular points. *Trans. Moscow Math. Soc.* **16** (1967) 227–313.

- [22] V. A. KOZLOV, V. G. MAZ'YA, J. ROSSMANN. *Elliptic boundary value problems in domains with point singularities*. Mathematical Surveys and Monographs, 52. American Mathematical Society, Providence, RI 1997.
- [23] J.-L. LIONS, E. MAGENES. *Problèmes aux limites non homogènes et applications. Vol. 3*. Dunod, Paris 1970. Travaux et Recherches Mathématiques, No. 20.
- [24] V. MAZ'YA, B. PLAMENEVSKIJ. On elliptic boundary value problems with discontinuous coefficients on manifolds with singularities. *Sov. Math., Dokl.* **14** (1973) 765–770.
- [25] V. G. MAZ'YA, B. A. PLAMENEVSKII. Elliptic boundary value problems on manifolds with singularities. *Probl. Mat. Anal.* **6** (1977) 85–142.
- [26] V. G. MAZ'YA, B. A. PLAMENEVSKII. L^p estimates of solutions of elliptic boundary value problems in a domain with edges. *Trans. Moscow Math. Soc.* **1** (1980) 49–97. Russian original in *Trudy Moskov. Mat. Obshch.* **37** (1978).
- [27] V. G. MAZ'YA, B. A. PLAMENEVSKII. Weighted spaces with nonhomogeneous norms and boundary value problems in domains with conical points. *Amer. Math. Soc. Transl. (2)* **123** (1984) 89–107.
- [28] V. G. MAZ'YA, J. ROSSMANN. On the Agmon-Miranda maximum principle for solutions of elliptic equations in polyhedral and polygonal domains. *Ann. Global Anal. Geom.* **9**(3) (1991) 253–303.
- [29] V. G. MAZ'YA, J. ROSSMANN. Weighted L_p estimates of solutions to boundary value problems for second order elliptic systems in polyhedral domains. *ZAMM Z. Angew. Math. Mech.* **83**(7) (2003) 435–467.
- [30] C. B. MORREY, JR. *Multiple integrals in the calculus of variations*. Die Grundlehren der mathematischen Wissenschaften, Band 130. Springer-Verlag New York, Inc., New York 1966.
- [31] C. B. MORREY, JR., L. NIRENBERG. On the analyticity of the solutions of linear elliptic systems of partial differential equations. *Comm. Pure Appl. Math.* **10** (1957) 271–290.
- [32] D. SCHÖTZAU, C. SCHWAB, T. P. WIHLER. *hp*-dGFEM for second order elliptic problems in polyhedra. Technical report, ETH Zürich 2009.

ADDRESSES

IRMAR, UNIVERSITÉ DE RENNES 1, CAMPUS DE BEAULIEU, 35042, RENNES CEDEX, FRANCE
E-mail address: martin.costabel@univ-rennes1.fr

IRMAR, UNIVERSITÉ DE RENNES 1, CAMPUS DE BEAULIEU, 35042, RENNES CEDEX, FRANCE
E-mail address: monique.dauge@univ-rennes1.fr

LAMAV, FR CNRS 2956, UNIVERSITÉ LILLE NORD DE FRANCE, UVHC, 59313 VALENCIENNES
CEDEX 9, FRANCE
E-mail address: snicaise@univ-valenciennes.fr