



**HAL**  
open science

## Torque minimization of the Delta parallel robot

Cédric Baradat, Vigen Arakelian, Sébastien Briot

► **To cite this version:**

Cédric Baradat, Vigen Arakelian, Sébastien Briot. Torque minimization of the Delta parallel robot. 20th Canadian Congress of Applied Mechanics: CANCEM 2005, May 2005, Montréal, Canada. hal-00451956

**HAL Id: hal-00451956**

**<https://hal.science/hal-00451956v1>**

Submitted on 26 Jun 2019

**HAL** is a multi-disciplinary open access archive for the deposit and dissemination of scientific research documents, whether they are published or not. The documents may come from teaching and research institutions in France or abroad, or from public or private research centers.

L'archive ouverte pluridisciplinaire **HAL**, est destinée au dépôt et à la diffusion de documents scientifiques de niveau recherche, publiés ou non, émanant des établissements d'enseignement et de recherche français ou étrangers, des laboratoires publics ou privés.

# Torque minimization of the Delta parallel robot

C. Baradat<sup>1,2</sup> V. Arakelian<sup>1</sup> S. Briot<sup>1</sup>

<sup>1</sup>Département de Génie Mécanique et Automatique, L.G.C.G.M. / EA3913  
Institut National des Sciences Appliquées (I.N.S.A.)  
20, Avenue des Buttes de Coësmes, CS 14315, 35043 Rennes Cedex, France

<sup>2</sup>Intelligent Surgical Instruments and Systems (I.S.I.S.)  
20, rue du Tour de l'Eau  
F-38400 Saint Martin d'Hères, France

cedric.baradat@ens.insa-rennes.fr  
vigen.arakelyan@insa-rennes.fr

**Abstract.** This paper proposes a new solution to the problem of torque minimization of the Delta robot. The suggested approach involves connecting to the initial structure a secondary mechanical system, which generates a vertical force applied to the platform of the robot. The conditions for optimization are formulated by the minimization of the root-mean-square and maximum values of the input torque due to the static and dynamic loads. The numerical examples show the efficiency of the suggested torque minimization approach.

**Keywords:** input torque, torque minimization, Delta robot

## 1. Introduction

The displacement of the platform (4) (Fig.1) of the Delta robot [1] is the result of the movement of the three articulated arms (2) mounted on the base (1), each of which is connected to a pair of parallel rods (3). The three orientations are eliminated by joining the rods in a common termination and the three parallelograms ensure the stability of the platform (4). This configuration of the robot has three degrees of freedom. The platform (4) stays constantly parallel to the base (1) and cannot rotate about the axis perpendicular to this plane.

It should be noted that the Delta robot is well known in the electronics, food and pharmaceutical sectors as a reliable system with the fast execution of light-duty tasks. However, in recent years, more attention has been paid to the increasing number of possible industrial applications, such as manipulation of the medical devices. In this case the mass of the manipulated object becomes heavier (70-80kg) and consequently the input torques increase.

In this context, a new approach for the minimization of the input torque of the Delta robot with high weight-carrying capacity is developed.

**Statement of problem.** For the minimization of the torques of the Delta robot with 3-DOF (Fig.1) we suggest adding a secondary mechanism between the base (1) and the platform (4). The aim of this approach is to create on the platform (4) a supplementary

vertical force which allows the minimization of the input torques of the robot.

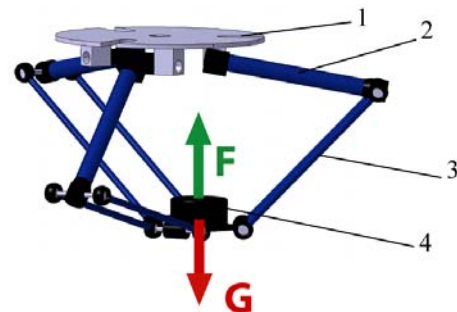

Fig. 1 Application of a force  $F$  to the platform of the Delta robot.

Thus, the problem studied is the following: to create a linkage which allows the development of a vertical force  $F$  and the minimization of the root-mean-square (r.m.s.) or maximal values of the torques.

## 2. Design of the suggested mechanism

The suggested system includes (Fig.2) a pantograph mechanism (5) mounted on the rotating stand (6) connected with the base.

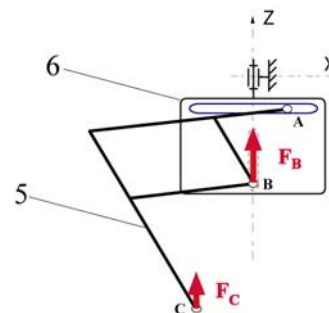

Fig. 2 Schematics of the suggested mechanism.

The input points A and B of the pantograph are located in the horizontal and vertical guides of the rotating stand. So the suggested system has three degrees of freedom: a rotation of the stand about the vertical axis and two translations along the guides. This allows the suggested system to be passive relatively to the Delta robot when the

point C is connected with the platform (8). The point B is connected also with an actuator which produces a vertical force. This vertical force  $F_B$  is used for the balancing of the static and dynamic loads. It is obvious that the determination of the balancing force  $F_C$  takes into account the magnification factor of the pantograph.



Fig.3. A CAD model of the prototype which is currently being developed in the I.N.S.A.

In Fig.3, the Delta robot with the suggested mechanism is shown. The illustrated prototype is realized on the base of the multi-loop pantograph mechanism. Such a design allows the introduction of the torque-minimizing mechanism in the free space between the three kinematic chains of the Delta robot.

### 3. Torque minimization

The three torques of the Delta robot can be presented in function of force  $F_C$  by the following expression:

$$\begin{bmatrix} \Delta M_1^{st} \\ \Delta M_2^{st} \\ \Delta M_3^{st} \end{bmatrix} = \begin{bmatrix} M_1^{st} \\ M_2^{st} \\ M_3^{st} \end{bmatrix} + \mathbf{J}^T \begin{bmatrix} 0 \\ 0 \\ F_C \end{bmatrix}, \quad (1)$$

where  $\Delta M_i^{st}$  is the optimized torque of the  $i^{\text{th}}$  actuator ( $i=1,2,3$ );  $M_i^{st}$  is the initial torque of the  $i^{\text{th}}$  actuator due to the gravity forces of the platform, the manipulated object and the movable links;  $\mathbf{J}$  is the Jacobian matrix of the robot, between the controlled point C of the robot and the actuated variables  $\theta_i$  [2]. For the minimization of the r.m.s. value of the torques, it is necessary to minimize the sum:

$$\Delta = \sum_{k=1}^N \left( \sum_{i=1}^3 (M_i^{st}(\mathbf{C}_k) + J_{3i}(\mathbf{C}_k) \cdot F_C)^2 \right), \quad (2)$$

where  $\mathbf{C}_k = (x_k, y_k, z_k)^T$  with  $x_k, y_k$  and  $z_k$  the Cartesian coordinates of the platform for the  $k^{\text{th}}$  position;  $M_i^{st}$  is the initial torque of the  $i^{\text{th}}$  actuator,  $J_{3i}(\mathbf{C}_k)$  is the element of the  $i^{\text{th}}$  column and the 3<sup>rd</sup> line of the Jacobian matrix of the robot for  $k^{\text{th}}$  position;  $N$  is the number of calculated positions of the robot. For this purpose, we shall achieve the condition:

$\frac{\partial \Delta}{\partial F_C} = 0$ , from which we determine the force:

$$F_C = - \frac{\sum_{k=1}^N \left( \sum_{i=1}^3 J_{3i}(\mathbf{C}_k) \cdot M_i(\mathbf{C}_k) \right)}{\sum_{k=1}^N \left( \sum_{i=1}^3 J_{3i}^2(\mathbf{C}_k) \right)}, \quad (3)$$

For the surgical Delta Robot developed by the society «ISIS» with payload 750N, the value of the added force determined by expression (3) is 964N.

Fig.4 shows the variations of the initial and optimized input torques of the examined robot for the whole working space of the robot. It should be noted that in the symmetric working space of the robot the maximum and the r.m.s. values of the torque are same for each actuator.

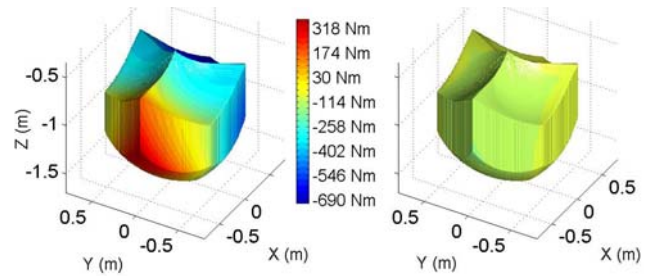

Fig. 4 Initial and optimized torques of the actuator 1.

Thus, the reduction of the r.m.s. value of the input torque is 95 %. It should be noted that the minimization of the maximum value of the torques is achieved. The reduction of the maximum value of the torque is 90%.

TABLE 1

Maximum values of the acceleration and velocity	input torque (maximum value) (N.m)		Applied force (N)	Gain
	initial	optimized		
a = 0.1 m/s <sup>2</sup> v = 0.26 m/s	645	57	956	91 %
a = 1.05 m/s <sup>2</sup> v = 0.79 m/s	645	110	897	83 %
a = 4.13 m/s <sup>2</sup> v = 1.57 m/s	645	326	779	49 %

This approach can also be used for the minimization of the dynamic loads. The obtained results, which are determined by the optimization module of the «ADAMS» software and the expressions given in [2], are shown in Table 1.

It is natural that the increase of velocity and acceleration leads to the reduction of the efficiency of the minimization because the added force  $F_C$  is always vertical and cannot compensate all effects of the inertia forces on the horizontal plane.

Finally, we would like to note that the patent concerning the suggested mechanism is pending.

### References

- [1] R. Clavel, "Device for movement and displacing of an element in space," US Patent n° 4976582, date: December 11, 1990.
- [2] K. Miller, R. Clavel, "The Lagrange-based model of Delta-4 robot dynamics," Robotersysteme, vol.8, pp.49-54, 1992.