



**HAL**  
open science

# Time Reversal UWB Communication: Experimental Study for High Data Rates in Dense Multipath Propagation Channels

Ijaz Haider Naqvi, Geoffroy Le Rosey, Ghais El Zein, Julien de Rosny, Philippe Besnier, Arnaud Tourin, Mathias Fink

## ► To cite this version:

Ijaz Haider Naqvi, Geoffroy Le Rosey, Ghais El Zein, Julien de Rosny, Philippe Besnier, et al.. Time Reversal UWB Communication: Experimental Study for High Data Rates in Dense Multipath Propagation Channels. The Mosharaka International Conference on Communications, Propagation and Electronics - CCS: Communications Circuits and Systems, (MIC-CPE 2009), Feb 2009, Amman, Jordan. pp.148-151. hal-00448869

**HAL Id: hal-00448869**

**<https://hal.science/hal-00448869>**

Submitted on 20 Jan 2010

**HAL** is a multi-disciplinary open access archive for the deposit and dissemination of scientific research documents, whether they are published or not. The documents may come from teaching and research institutions in France or abroad, or from public or private research centers.

L'archive ouverte pluridisciplinaire **HAL**, est destinée au dépôt et à la diffusion de documents scientifiques de niveau recherche, publiés ou non, émanant des établissements d'enseignement et de recherche français ou étrangers, des laboratoires publics ou privés.

# Time Reversal UWB Communication: Experimental Study for High Data Rates in Dense Multipath Propagation Channels

<sup>1</sup>I. H. Naqvi, <sup>1</sup>G. El Zein, <sup>2</sup>G. Lerosey, <sup>2</sup>J. de Rosny, <sup>1</sup>P. Besnier, <sup>2</sup>A. Tourin and <sup>2</sup>M. Fink  
{ijaz-haider.naqvi@insa-rennes.fr }

<sup>1</sup>*Institute of Electronics and Telecommunication Rennes (IETR), UMR CNRS 6164  
National Institute of Applied Sciences (INSA), 20 Avenue des Buttes de Coesmes, 35043, Rennes France.*

<sup>2</sup>*Laboratoire Ondes et Acoustique (LOA), UMR CNRS 7587, ESPCI-PARITECH, Université Diderot,  
10 rue Vauquelin, 75005 Paris, France.*

**Abstract**—High data rate communication for a Time Reversal UWB communication system is experimentally studied using binary pulse amplitude modulation in dense multipath propagation channels. Experiments are done for inter symbol intervals ranging from 64ns to 1ns. Signal, Interference and Noise components are separated from the received signal and their bit error rates are computed. The received signals are neither processed nor equalized. It is shown that at very high data rates ( $\geq 125Mbps$ ), the performance of the system is limited by inter symbol interference. However at high data rates ( $\leq 125Mbps$ ), time reversal system gives good BER performance in the presence of inter symbol interference.

**Index Terms**—Indoor propagating channel, Reverberating chamber, Pulse Amplitude Modulation (PAM), bit error rate (BER), time reversal (TR), ultra-wideband (UWB).

## I. INTRODUCTION

Pulsed Ultra-Wideband (UWB) is a communication technique in which high data rate can be achieved by making use of ultra large bandwidth. The ability of pulsed UWB to resolve individual multi-path components is exploited in the recent research for short range communication applications. However, large number of resolvable paths and low power limitations necessitate a complex receiver system. To collect the received signal energy, Rake receiver, transmit-reference or the decision feedback autocorrelation receiver can be implied [1]-[3]. Each technique has different difficulties and drawbacks. Time Reversal (TR) has been proposed as a technique to shift the design complexity from the receiver to the transmitter. Classically, TR has been applied in acoustics and under water communication applications [4],[5], but recently, it has been widely studied for UWB communication [6]-[12]. The received signal in a TR system is considerably focused in spatial and temporal domains. As a result, the received power is concentrated within few taps and the effects of inter symbol interference (ISI) are greatly reduced. The receiver system becomes simpler than

without TR and signal can be collected using a simple energy threshold detector [6]. Spatial focusing enables very low co-channel interference in a multi cell system, resulting in an efficient use of bandwidth in the overall network.

In pulsed UWB communication systems, channel delay spread causes significant ISI. The performance of RAKE receivers in the presence of such ISI is studied in a number of papers [13],[14]. To the best of authors' knowledge, high data rate communication in the presence of ISI has never been studied for TR communication system.

In this paper, high data rate communication with TR is experimentally studied in a reverberating chamber (RC) and in a typical indoor environment. Experiments are done for inter symbol intervals ( $T_s$ ) ranging from 64ns to 1ns (15.62 Mbps to 1Gbps). It is shown for data rates smaller than 125Mbps, the bit error rate (BER) is low enough for good transmissions for a given value of signal to noise ratio (SNR). However, for higher data rates, the ISI becomes large and BER saturates even for high SNR.

## II. TIME REVERSAL

TR is essentially a pre-Rake scheme in which time reversed channel impulse response (CIR) is used as transmitter pre-filter. The TR wave then propagates in an invariant channel following the same paths in the reverse order. Finally at the receiver, all the paths add up coherently in the delay and spatial domains. For dense multipath propagation channels, strong temporal compression and high spatial focusing can be achieved with a focusing gain of about 8 dB [10]. For communication purposes, this gain improves the transmission range. Inter Symbol Interference (ISI) effects are mitigated by temporal compression and multiuser interference is reduced due to spatial focusing. The received signal ( $y_j(t)$ ) at the intended receiver ( $j$ ) can be mathematically represented as:

$$y_j(t) = s(t) \star h_{ij}(-t) \star h_{ij}(t) = s(t) \star R_{ij}^{auto}(t) \quad (1)$$

<sup>1</sup>This work was done by joint measurement campaign of IETR and LOA for ANR project MIRTEC.

where  $h_{ij}(t)$  is the CIR from the transmitting point ( $i$ ) to an intended receiver ( $j$ ),  $s(t)$  is the transmitted signal,  $\star$  denotes convolution product and  $R_{ij}^{auto}(t)$  is the autocorrelation of the CIR,  $h_{ij}(t)$ . The received signal at any non intended receiver ( $k$ ) is written as:

$$y_k(t) = s(t) \star h_{ij}(-t) \star h_{ik}(t) = s(t) \star R_{ikj}^{cross}(t) \quad (2)$$

where  $h_{ik}(t)$  is the CIR from the transmitting point ( $i$ ) to an unintended receiver ( $k$ ) and  $R_{ikj}^{cross}(t)$  is the cross-correlation of the CIR  $h_{ik}(t)$  and  $h_{ij}(t)$ . If the channels are uncorrelated, then the signal transmitted for one receiver will act as a noise for a receiver at any other location. Thus, a secure communication is achieved with low probability of detection and low probability of interception.

In the practical implementation of the TR system, the pre-coding filter is truncated in time to reduce the filter length and thus the system complexity. The truncated response is represented as  $h'_{ij}(-t)$ . The transmitted TR signal is normalized such that average energy of the transmitted signal respects the limits of UWB spectral mask issued by FCC. For data communication purpose, the transmitted symbols are modulated by binary pulse amplitude modulation (BPAM) scheme. The  $k^{th}$  symbol,  $d_k$ , of the symbol sequence is equal to 1 or -1 for the data bits 1 or 0 respectively. Therefore, the received signal at the intended receiver ( $j$ ) is written as:

$$y(t) = A \underbrace{\sum_k d_k h'_{ij}(-t + kT_s)}_{\text{Transmitted RF signal}} \star \underbrace{h_{ij}(t)}_{\text{CIR}} \quad (3)$$

where  $A$  is a normalization factor and  $T_s$  is the inter-symbol interval. As the amplitude of the peak of the received signal is proportional to the energy of the transmitted signal ( $\int h'_{ij}{}^2 dt$ ), the truncation process decreases the peak of the received signal. Due to BPAM, the polarity of the received peak signals is specified by the transmitted data bit and is used for the detection of the data bits.

### III. EXPERIMENTAL SETUP AND RESULTS

Experiments are done in a reverberating chamber (RC) and in an indoor environment. The indoor environment consists of a laboratory room where the RC is also located (see Fig. 1). Consequently, the metallic walls of the RC allow accomplishing a Non Line of Sight (NLOS) propagation scenario. The room is also furnished with standard office equipments: tables, PCs and seats. Conical Mono-pole Antennas(CMA) are used at both the transmitter and the receiver sides. The distance between the transmitter and the receiver is 5.5m in the RC and 10m in the indoor configuration. The antennas are always kept 1m above the ground. The signals are generated by an Arbitrary Waveform Generator (Tektronix AWG 7052) with a maximum sampling rate of 5 GS/s. At the receiver end, the signals are captured by a Digital Storage Oscilloscope (Tektronix DSO 6124C) with a maximum sampling rate of 40 GS/s. The experimental setup is shown in the Fig. 2.

At first, the channel impulse response (CIR) is measured. A narrow pulse with a rise time of 500 ps and a bandwidth

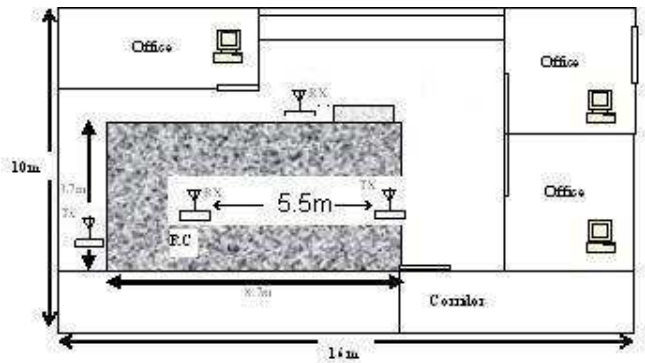

Fig. 1. Measurement environment layout

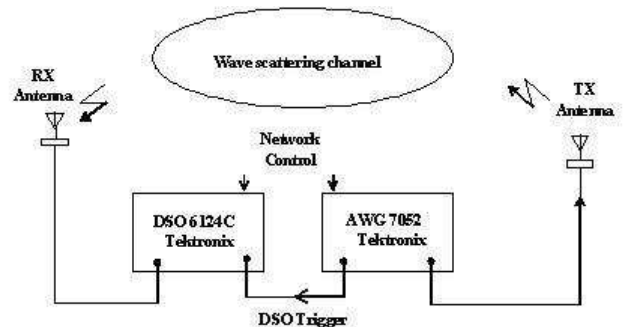

Fig. 2. Experimental Setup

of 2.0 GHz is transmitted in the channel with AWG and CIR is detected by DSO with a sampling rate of 10 GS/s. The measured CIR is then truncated such that the truncated version of the CIR keeps 80% and 97% of the total energy in the RC and the indoor environment respectively. The truncated CIR is reversed in time and the RF signal to transmit is computed from Eq. 3. The signal is then down sampled to 5 GS/s and transmitted by the AWG in the same channel. As the length of the CIR ( $T_{sig}$ ) is larger than  $T_s$ , high ISI is present. Temporal compression property of the TR reduces ISI. Nevertheless, at such high data rates ISI is the critical factor to limit the performance of the system. As the experiments are done in the RC and indoor, we suppose that the channels do not change during this time.

The received signal is recorded by the DSO. First, a single record is performed. This record is a combination of the *Signal*, *Interference* and *Noise* (S+I+N) components. Then, to suppress *Noise* contribution in the measured signal, same RF signal is transmitted 256 times, and all of the 256 received signals are averaged together. Finally, by transmitting only one symbol and operating the DSO in the average mode, *Signal* is measured. Thus there are three measured signals; S, S+I and S+I+N. From these measured signals we can separate the contributions of *Signal*, *Interference* and *Noise*. All measured signals are normalized such that every data symbol is transmitted with the same energy.

Fig. 3 shows *Signal*, *Noise* and *Interference* contributions for the first fifty symbols in the indoor environment for a

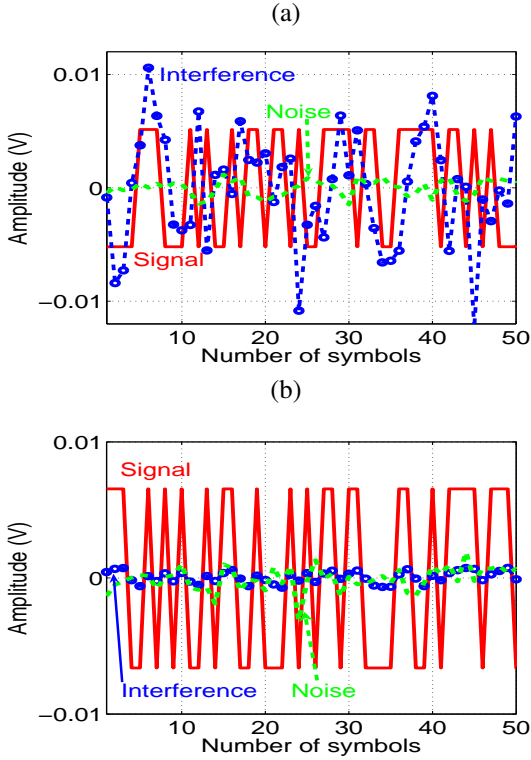

Fig. 3. *Signal*, *Interference* and *Noise* component for a SNR of 15 dB in an indoor environment for a inter-symbol interval of a) 1ns b) 64ns

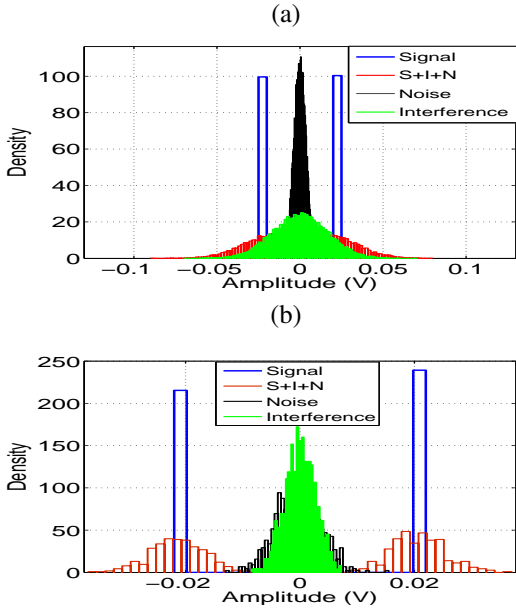

Fig. 4. Amplitude distribution of *Signal*, *Interference* and *Noise* components for a SNR of 15 dB in a reverberating chamber for a inter-symbol interval of a) 1ns b) 64ns

SNR of 15 dB and for a  $T_s$  of 1ns and 64ns. For  $T_s = 1ns$ , *Interference* limits the performance of the system and is much greater than *Noise* (see Fig. 3 a). However for  $T_s = 64ns$ , *Noise* power becomes greater than *Interference* power at a SNR of 15 dB.(see Fig. 3 b).

TABLE I  
COMPARISON OF SIR FOR DIFFERENT  $T_s$  IN THE REVERBERATING CHAMBER AND IN THE INDOOR CHANNEL FOR A FIXED SNR OF 15 DB

RC			Indoor Channel		
$T_s$	SIR (dB)	$\frac{T_{sig}}{T_s}$	$T_s$	SIR (dB)	$\frac{T_{sig}}{T_s}$
1	1.8842	8044	1	-1.1261	112
2	4.7186	4022	2	3.0600	56
4	7.4018	2011	4	4.3485	28
8	10.2610	1055	8	5.1058	14
16	12.7883	503	16	10.2710	7
32	15.5234	251	32	13.1763	3.5
64	18.2751	125	64	24.4804	1.7

Fig. 4 shows the amplitude distribution of *Signal*, *Noise* and *Interference* in the RC for a SNR of 15 dB and for a  $T_s$  of 1ns and 64ns. At  $T_s = 1ns$ , the variance of *Interference* is greater than the variance of *Noise*. The combined power of *Noise* and *Interference* is so high that the distribution of the received signal (*Signal* + *Interference* + *Noise*) can not be distinguished into positive and negative parts. However for  $T_s = 64ns$ , *Noise* power becomes greater than interference power at a SNR of 15dB (see Fig. 4 b). The *Signal* power is greater than the combined power of *Noise* and *Interference*. Thus, the distribution of the received signal can easily be distinguished into positive and negative parts.

Table I shows for the RC and indoor channel, signal to interference ratio (SIR) of the received signal peaks for different  $T_s$  for a fixed SNR of 15 dB. As expected, SIR increases with  $T_s$  for both channels. In the RC, SIR increases with  $T_s$  linearly, whereas in the indoor channel SIR increases rapidly for  $T_s$  higher than 8ns. The ratio  $\frac{T_{sig}}{T_s}$  can help to interpret this rapid increase in SIR.  $T_{sig}$  is a direct measurement of the delay spread of the CIR as it is the truncated version of the time reversed CIR. In the RC,  $T_{sig}$  (and thus the delay spread) is much larger than the  $T_s$  for all  $T_s$ . However, in the indoor channel,  $T_{sig}$  becomes somewhat comparable to  $T_s$  when  $T_s = 32ns$  and  $T_s = 64ns$ . A large increase in the SIR is observed when the ratio  $\frac{T_{sig}}{T_s}$  is close to 1. This explains the jump in the SIR for the indoor channel when  $T_s$  increases from 32ns to 64ns in the indoor channel.

Fig. 5 shows the bit error rate (BER) comparison for different  $T_s$  in the indoor channel. This curve is obtained by adding synthetic noise (AWGN) to *Signal* + *Interference* components measured from the signals averaged 256 times. The SNR varies from 0 to 20 dB. For each SNR, the BER is calculated for  $10^8$  transmitted bits.

Similarly, BER is calculated for different data rates (data rate =  $\frac{1}{T_s}$ ) ranging from 15.62Mbps to 1Gbps. For a data rate of 62.5 Mbps ( $T_s = 16ns$ ), the BER performance is quite good: a BER of  $10^{-5}$  is achieved for a SNR of 20 dB. However, for higher data rates, the BER curves reach a plateau. Indeed, in such a case, the ISI dominates the BER. It must be noted that these data rates are raw data rates based on baseband communication without any equalization at the receiver. The use of ISI canceling equalizers, such as decision feedback equalizer, might improve the BER performance.

Fig. 6 shows the BER comparison for different  $T_s$  in the

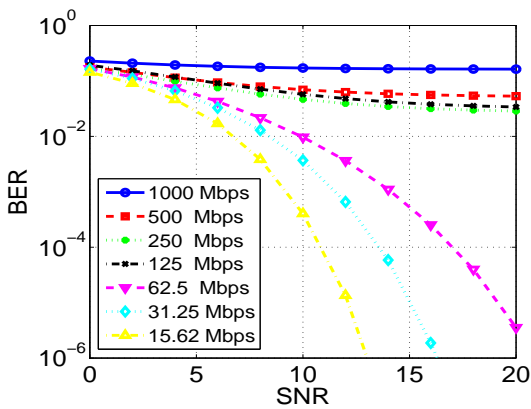

Fig. 5. BER performance of TR system for  $64ns \leq T_s \leq 1ns$  in an indoor environment

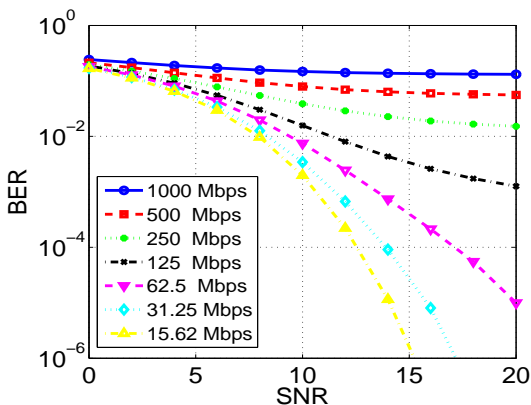

Fig. 6. BER performance of TR system for  $64ns \leq T_s \leq 1ns$  in a reverberating chamber

RC. Comparison of Fig. 5 and Fig. 6 suggests that for lower data rates ( $16ns \leq T_s \leq 64ns$ ), the BER performance is better for the indoor channel. For the higher data rates ( $1ns \leq T_s \leq 8ns$ ), the BER performance is better in the RC. For instance, BER of  $3 \times 10^{-3}$  can be achieved for a fixed SNR of 20 dB for a data rate of 125 Mbps ( $T_s = 8ns$ ) in the RC. Whereas, in the indoor channel, BER is saturated well above  $10^{-2}$  for a data rate of 125 Mbps. This behaviour is in accordance to the SIR performance of the two channel environments. For a fixed SNR, SIR for the measured signal in the indoor channel is very poor for high data rates ( $1ns \leq T_s \leq 8ns$ ). For lower data rates ( $16ns \leq T_s \leq 64ns$ ), SIR performance in the indoor channel is comparable or in some cases better than the RC (see Table I).

For the future work, study needs to be done to reduce the effects of ISI for high rate communication in a TR system. The performance of the TR system can also be compared by using pulse position modulation scheme with or without ISI canceling mechanism.

#### IV. CONCLUSION

High data rate communication for a Time Reversal UWB communication system is experimentally studied using binary

pulse amplitude modulation. Experiments have been done in a typical indoor environment and in a reverberating chamber for different symbol times ( $T_s$ ) ranging from 1ns to 64ns. Signal, Interference and Noise components are extracted from the measured received signal and are compared for different  $T_s$  at a fixed SNR. It is observed that inter symbol interference increases with the decrease in  $T_s$  and saturates the BER performance. Finally, it is shown that for higher data rates, the performance is better in the reverberating chamber whereas for lower data rates the performance is better in the indoor channel environment.

#### REFERENCES

- [1] R. Hoor and H. Tomlinson, "Delay-Hopped Transmitted-Reference RF Communications," Proc. IEEE 2nd Ultra Wideband Systems and Technologies (UWBST02), Baltimore, MD, pp. 265-269, May 2002.
- [2] R. J. Fontana, E. Richley, and J. Barney, "Commercialization of an Ultra Wideband Precision Asset Location System," Proc. IEEE Conference UWB systems and Technologies, Reston, VA, 2003.
- [3] J. D. Choi and W. E. Stark, "Performance of Ultra-Wideband Communications with Suboptimal Receivers in Multipath Channels," IEEE Journal on Selected Areas in Communications, vol. 20, pp. 1754-1766, Dec. 2002.
- [4] M. Fink, "Time-reversed acoustic", Scientific Amer., pp. 67-73, Nov.1999.
- [5] A. Derode, A. Tourin, J. D. Rosny, M. Tanter, S. Yon, and M.Fink, "Taking advantage of multiple scattering to communicate with time-reversal antennas", Phys. Rev. Lett., vol. 90, no. 1, pp. 1014301-1014301-4, 2003.
- [6] H. T. Nguyen, I. Z. Kovcs, P. C.F. Eggers, "A Time Reversal Transmission Approach for Multiuser UWB Communications", IEEE Transactions On Antennas and Propagation, Vol. 54, NO. 11, Nov. 2006.
- [7] P. Kyritsi, G. Papanicolaou, P. Eggers, and A. Oprea, "MISO time reversal and delay-spread compression for FWA channels at 5 GHz", IEEE Antennas Wireless Propag. Lett., vol. 3, no. 6, pp. 96-99, 2004.
- [8] H. T. Nguyen, J. B. Andersen, and G. F. Pedersen, "The potential use of time reversal technique in multiple elements antenna systems", IEEE Commun. Lett., vol. 9, no. 1, pp. 40-42, Jan. 2005.
- [9] R. C. Qiu, C. Zhou, N. Guo, and J. Q. Zhang, "Time Reversal with MISO for Ultra-Wideband Communications: Experimental Results", IEEE Antenna and Wireless Propagation Letters, 2006.
- [10] A. Khaleghi, G. El Zein, I. H. Naqvi, Demonstration of Time-Reversal in Indoor Ultra-Wideband Communication: Time Domain Measurement, ISWCS 2007, Trondheim, Norway.
- [11] A. Khaleghi, G. El Zein, "Signal Frequency And Bandwidth Effects On The Performance Of UWB Time-Reversal Technique", Loughborough Antennas and Propagation Conference 2007, Loughborough, UK.
- [12] I. H. Naqvi, A. Khaleghi, G. El Zein "Performance Enhancement of a Multiuser Time Reversal UWB Communication System", IEEE International Symposium on Wireless Communication Systems 2007, Trondheim, Norway,
- [13] A. Rajeswaran, V. Somayazulu, and J. Foerster, RAKE performance for a pulse based UWB system in a realistic UWB indoor channel, in IEEE Int. Conf. Commun. (ICC), vol. 4, Anchorage, AK, May 2003, pp. 2879-2883
- [14] A. Klein, I. Brown, D.R., D. Goeckel, and J. Johnson, C.R., RAKE reception for UWB communication systems with intersymbol interference, in IEEE Workshop on Signal Proc. Advances Wireless Commun. (SPAWC 2003), Rome, Italy, June 2003, pp. 244-248.
- [15] F. Ramirez-Mireles, R. A. Scholtz, "Performance of Equicorrelated Ultra-Wideband Pulse-Position-Modulated Signals in the Indoor Wireless Impulse Radio Channel", IEEE Pacific Rim Conference 1997.
- [16] Bo Hu, N. C. Beaulieu, "Accurate Evaluation of Multiple-Access Performance in TH-PPM and TH-BPSK UWB Systems", IEEE Transaction on Communications, vol. 52, no. 10, Oct. 2004.
- [17] F. Ramirez-Mireles, "Performance of Ultrawideband SSMA Using Time Hopping and M-ary PPM", IEEE Journal on Selected Areas in Communications, vol. 19, no. 6, June 2001.