



**HAL**  
open science

# Phase Noise Behaviour of Fractional-N Synthesizers with Sigma-Delta Dithering for Multi- Radio Mobile Terminals

Vaclav Valenta, Genevieve Baudoin, Martine Villegas

► **To cite this version:**

Vaclav Valenta, Genevieve Baudoin, Martine Villegas. Phase Noise Behaviour of Fractional-N Synthesizers with Sigma-Delta Dithering for Multi- Radio Mobile Terminals. Fourth conference on Ph.D. Research in Microelectronics and Electronics, PRIME 2008, Jun 2008, Istanbul, Turkey. pp.ISBN: 978-1-4244-1984-5. hal-00447429

**HAL Id: hal-00447429**

**<https://hal.science/hal-00447429>**

Submitted on 14 Jan 2012

**HAL** is a multi-disciplinary open access archive for the deposit and dissemination of scientific research documents, whether they are published or not. The documents may come from teaching and research institutions in France or abroad, or from public or private research centers.

L'archive ouverte pluridisciplinaire **HAL**, est destinée au dépôt et à la diffusion de documents scientifiques de niveau recherche, publiés ou non, émanant des établissements d'enseignement et de recherche français ou étrangers, des laboratoires publics ou privés.

# Phase Noise Behaviour of Fractional-N Synthesizers with $\Delta\Sigma$ Dithering for Multi-Radio Mobile Terminals

Václav VALENTA

Université Paris-Est<sup>†</sup> and Brno University of Technology<sup>\*</sup>  
<sup>‡</sup>ESYCOM, ESIEE; <sup>\*</sup>DREL  
<sup>†</sup>Noisy-le-Grand, France; <sup>\*</sup>Brno, Czech Republic  
 valentav@esiee.fr

Geneviève BAUDOIN, Martine VILLEGAS

Université Paris-Est  
 ESYCOM, ESIEE  
 Noisy-le-Grand, France  
 baudoing@esiee.fr, villegam@esiee.fr

**Abstract**— This paper presents phase noise behaviour and design aspects of PLL based frequency synthesizers with  $\Delta\Sigma$  dithering for cognitive multi-radio mobile terminals. Principal features of PLL based frequency synthesizers and 1-bit  $\Delta\Sigma$  dithering are presented and simulated. Moreover, frequency synthesizer requirements for main standards in the frequency band 800 MHz to 6 GHz are investigated as well.

## I. INTRODUCTION

During the recent past, there has been a significant progress in wireless communications in terms of integration of various communication standards into a single mobile terminal. Instead of using multiple transceivers for different standards, the goal is to employ a single reconfigurable radio transceiver that is able to achieve all requirements of different communication standards. The goal of this evolution is to reduce the number of external components and to increase the integration in the low-cost CMOS technology. Another stage which pursues the evolution towards the cognitive radio and implies flexibility of each stage of the communication chain is the cognitive multi-radio. Cognitive multi-radio has the capability of the multi-standard concept and moreover it is capable to perform an efficient environment spectrum scanning in order to switch accordingly to an appropriate communication standard.

Single chip radios that support WLAN 802.11 a/b/g standards have already been proposed in [1], [2]. Another example of integration of cellular standards GSM 900/1800 and UMTS in a single chip can be found in [3]. These multi-radio proposals are mainly based on the direct conversion technique which is the most suitable techniques for 2G, 3G and 4G multi-radio terminals [4]. This is due to the fact, that the direct conversion eliminates the sensitivity to the image frequency and hence, it is not necessary to build any additional filters for the image rejection. One of the most challenging tasks in the multi-radio transceiver is the design of the frequency synthesizer. Frequency synthesizer has to provide all necessary frequencies for the down and up conversion with proper channel spacing that corresponds to

the channel bandwidth and the raster of the communication standard. Frequency switching has to be performed agilely, with respect to the standard settling time requirements. Moreover, the local frequency synthesizer has to fulfil the tightest signal purity requirements which can be expressed in terms of the phase noise and the spurious output. These requirements given by the most diffused standards in the frequency band 800 MHz to 6 GHz, namely by GSM, UMTS, Bluetooth, WiFi and WiMAX, are summarized in Table 1 [5]-[9].

It can be seen, that the most critical local oscillator requirements in terms of the phase noise are imposed by the GSM standard. This is due to the fact that the powers of the in-band unmodulated interfering signals, so called blockers, are at very high level [10].

TABLE I. RF SPECIFICATIONS FOR THE MULTI-RADIO FREQUENCY SYNTHESIZER

Standard	Frequency Band [MHz]	Channel / Raster [MHz]	Settling Time[ $\mu$ s]	Phase Noise [dBc/Hz]
<b>GSM 900/1800</b>	880-960	0.2/0.2	577	-122@0.6 MHz
	1710-1880		150 (GPRS)	-132@1.6 MHz -139@3 MHz
<b>UMTS FDD/TDD</b>	1920-2170 1900-2025	5/0.2	200	-132@3 MHz -132@10 MHz -144@15 MHz
<b>Bluetooth</b>	2402-2480	1/1	150	-84@1 MHz -114@2 MHz -129@3 MHz
<b>Mobile WiMAX IEEE 802.16e</b>	2300-2400	3.5-10 / 0.25	< 100 (HFDD)	Phase Jitter < 1° rms
	2305-2320			
	2469-2690			
	3300-3400 3400-3800			
<b>WiFi IEEE 802.11a</b>	5150-5350	20/20	500	-102@1 MHz -125@25 MHz
	5470-5825			
<b>WiFi IEEE 802.11b</b>	2412-2472	20/5	225	
<b>WiFi IEEE 802.11g</b>	2412-2472	20/5	225	

Various approaches for multi-radio frequency synthesizers have been proposed in [11]-[13], considering wideband tuning range VCO, use of multiple PLL loops or all digital PLL design. Although there are many techniques for frequency synthesis, the dominant technique used in wireless technology is based on the PLL principle. This technique is considered in this article. First, a linearized PLL model is described along with characteristic transfer functions. Furthermore, noise sources in the  $\Delta\Sigma$  fractional- $N$  PLL circuit are studied and simulated.

## II. PLL ARCHITECTURE

### A. PLL Linearized Model

Figure 1 displays a model of the  $\Delta\Sigma$  fractional- $N$  PLL. This model includes a charge pump phase-frequency detector CP/PFD with the gain  $K_d$ , a loop filter with the transfer function  $F(s)$ , a VCO with the gain  $K_o/s$  and a frequency divider dividing by  $N$ . The gain  $K_d$  can be written as follows:

$$K_d [A/rad] = I_{cp} / 2\pi. \quad (1)$$

The charge pump current  $I_{cp}$  is proportional to the phase error in the phase detector and after low pass filtering by  $F(s)$ , it is applied to the control input of the VCO. In a conventional PLL, the frequency at the PLL output equals  $f_{ref}N$ . Divide ratio  $N$  can be an integer or a fractional value. In a fractional- $N$  divider, the fractional division is achieved by periodic altering the division value between two integer values  $N$  and  $N+1$ , hence the average division becomes a fraction. However, the periodic switching between two division values leads to a sawtooth phase error which creates several spurious fractional tones. This problem is solved with help of  $\Delta\Sigma$  modulator, which randomize the division ratio in the PLL but on the other hand, it introduces quantization noise into the loop as described in Section III.

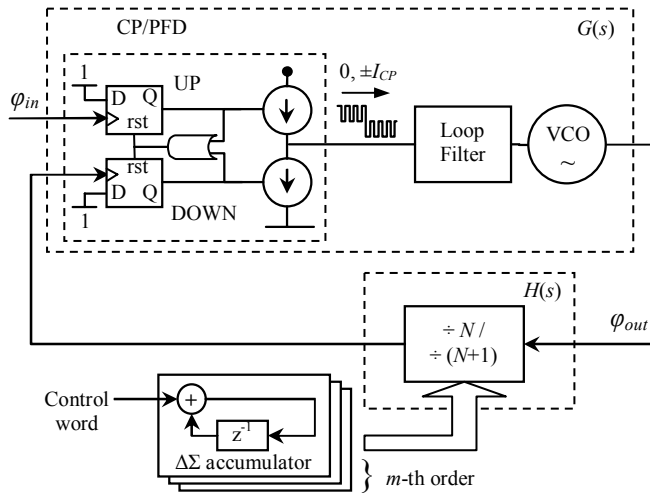

Figure 1. A Simplified model of fractional- $N$  PLL frequency synthesizer with  $\Delta\Sigma$  modulator that controls the division ration of the divider.

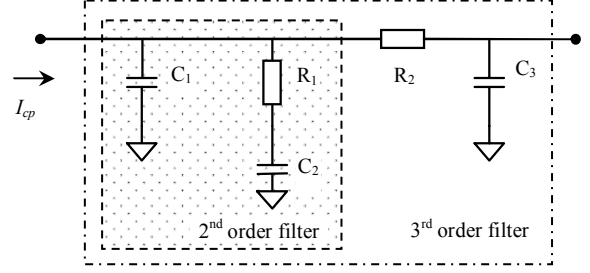

Figure 2. Second and third order passive filter.

According to the control theory, the effect of a closed feedback loop on the input signal  $\phi_{in}$  can be described by the closed loop transfer function  $T(s)$  as:

$$T(s) = \frac{\phi_{out}(s)}{\phi_{in}(s)} = \frac{G(s)}{1 + G(s)H(s)} = \frac{\frac{K_d K_o}{s} F(s)}{1 + \frac{K_d K_o}{s} F(s) \frac{1}{N}}, \quad (2)$$

where the  $G(s)$  represents the forward transfer function and the term  $G(s)H(s)$  open loop transfer function.  $H(s)$  corresponds to the division factor  $1/N$ . Since the input signal at the loop filter is a charge pump current  $I_{cp}$ , the filter transfer function represents the transimpedance. The transimpedance of the 2<sup>nd</sup> order filter shown in Fig. 2 reads:

$$F(s) = \frac{1 + sC_2R_1}{s(C_1 + C_2) \left( 1 + s \frac{C_1C_2R_1}{C_1 + C_2} \right)}. \quad (3)$$

In order to boost the reference spur suppression at the output of the PLL, additional RC low pass stages can be added [14]. However, additional passive components will contribute to the total phase noise at the output of the PLL.

## III. PLL PHASE NOISE SOURCES

Phase noise performance of the frequency synthesizer is very important issue for many applications, notably for OFDM systems. The phase noise phenomenon in the PLL is a result of the thermal noise, shot noise,  $1/f$  noise in all the active or passive components. Hereafter, we will analytically describe the phase noise behavior in the PLL circuit for the following noise sources: reference oscillator noise, VCO noise, loop filter noise and  $\Delta\Sigma$  quantization noise.

### A. Reference Noise

Reference oscillator's phase noise performance has been predicted with help of the Leeson's model [15] as:

$$S_{ref}(f_m) [dBc/Hz] = 10 \log \left[ \frac{FkT}{2A} \left( 1 + \frac{1}{f_m^2} \left( \frac{f_o}{2Q} \right)^2 \right) \left( 1 + \frac{f_f}{f_m} \right) \right], \quad (4)$$

where  $f_m$  is the frequency offset,  $F$  represents the noise figure of the oscillator's amplifier,  $k$  is the Boltzmann's constant  $1.38 \cdot 10^{-23}$  J/K,  $T$  is the absolute temperature,  $A$  is the power available to the amplifier from the resonator,  $Q$  is the loaded quality factor of the resonator,  $f_O$  is the carrier frequency and  $f_f$  is the flicker corner frequency. According to Fig. 1, the transfer function of the reference oscillator's noise  $S_{ref}$  injected at the input of the PLL corresponds to the low-pass filter function  $G_{LPF}$  with a loop bandwidth  $B_{PLL}$ .  $B_{PLL}$  is the frequency at which the open loop gain magnitude equals 1. Phase noise contribution  $S_{ref,out}$  from the reference oscillator to the PLL output becomes:

$$\begin{aligned} S_{ref,out}(f) &= S_{ref}(f) \left( \frac{1}{H(f)} \right)^2 \left| \frac{G(f)H(f)}{1+G(f)H(f)} \right|^2 \\ &= S_{ref}(f) N^2 |G_{LPF}(f)|^2. \end{aligned} \quad (5)$$

Fig. 3 demonstrates that the reference noise is low-pass filtered and hence the phase noise contribution at the PLL output becomes dominant at lower frequency offsets. Moreover, the reference phase noise is amplified by factor  $N$ , which is in this example equal to 2439 ( $\approx 67.8$  dB). In order to keep low in-band phase noise, the division factor should be set as low as possible. This problem is solved by fractional- $N$  dividers that can provide arbitrary small frequency resolution without the need of low reference frequency. Hence, the in-band phase noise performance is improved significantly [5].

### B. VCO Noise

VCO phase noise  $S_{VCO}$  was modeled according to the Leeson's model as in (4). The transfer function is calculated similarly as in the reference noise case. The noise injected this time at the output of the VCO is high-pass filtered and hence the contribution of this noise to the PLL output reads:

$$S_{VCO,out}(f) = S_{VCO}(f) \left| \frac{1}{1+G(f)H(f)} \right|^2 = S_{VCO}(f) |G_{HPF}(f)|^2. \quad (6)$$

Due to the high-pass filtering, the VCO's phase noise will be suppressed within the loop bandwidth  $B_{PLL}$  and the dominant noise contribution will appear at higher frequency offsets. This phenomenon is depicted in Fig. 4.

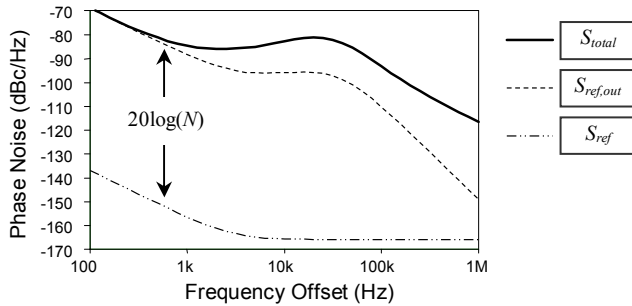

Figure 3. Reference oscillator's noise performance at the input and at the output of the PLL. Moreover, total phase noise at the PLL output is shown.

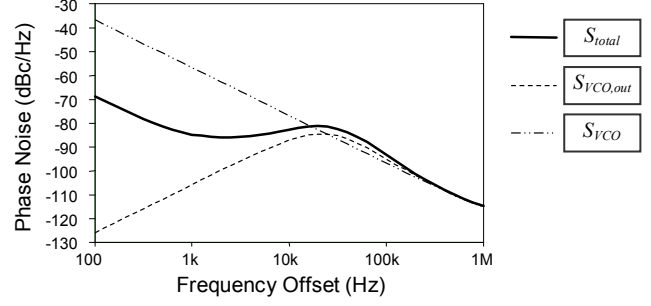

Figure 4. VCO's noise performance for open and closed loop case.

Furthermore, the out-band phase noise will drop to the VCO's noise floor which is defined by the oscillator's output power  $A$  and the system's noise figure  $F$ . Total integrated phase noise at the output of the PLL can be minimized by means of  $B_{PLL}$  reduction, however this will lead to settling time degradation. Hence, the tradeoff between the minimum loop bandwidth and the settling time has to be taken into account for design. A simplified tradeoff has been presented in [5] as  $B_{PLL} = 4 / t_{lock}$ , where  $t_{lock}$  is the settling time.

### C. Loop Filter Noise

A passive loop filter consists of only resistive and capacitive components. Hence, the output voltage noise is the result of the thermal noise present in the real part of the complex admittance of the loop filter. Two sided PSD of current fluctuations is defined by the Nyquist equation as:

$$S_{fil}(f) \approx 2kT \operatorname{Re}(Y(f)), \quad (7)$$

where  $Y$  is the loop filter admittance that corresponds to the inverse filter transimpedance  $1/F(f)$ . Furthermore, this thermal noise is band-pass filtered (see Fig. 5) by the PLL and the noise contribution to the output of the PLL reads:

$$S_{fil,out}(f) = S_{fil}(f) |F(f)|^2 |K_0 / j2\pi f|^2 |G_{HPF}(f)|^2. \quad (8)$$

Fig. 5 shows the loop filter noise contribution to the PLL output for two values of the CP current. If the CP current is increased while keeping the same PLL transfer function, the thermal noise will be reduced since the loop filter resistor becomes smaller in order to keep the same output voltage.

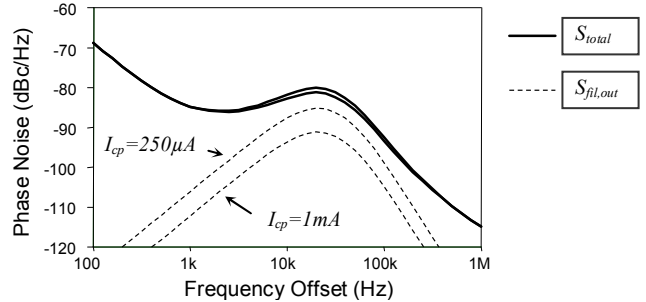

Figure 5. Noise contribution of the 2<sup>nd</sup> order filter for two values of  $I_{cp}$ .

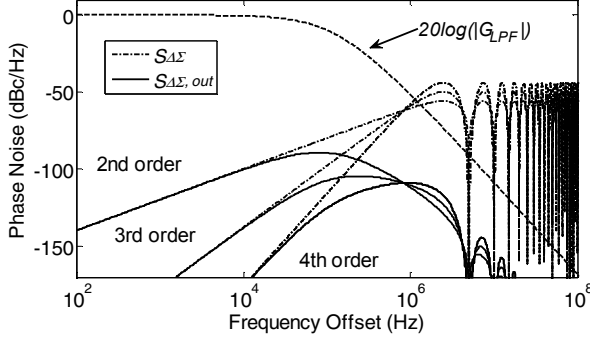

Figure 6. Noise spectrum induced by the 2<sup>nd</sup>, 3<sup>rd</sup> and 4<sup>th</sup> order  $\Delta\Sigma$  modulator (dash dot) and the noise spectrum at the PLL's output (full line).

#### D. Quantization Noise from $\Delta\Sigma$ Modulator

The  $\Delta\Sigma$  modulator used in a synthesizer is to randomize the instantaneous division ratio and hence push phase noise associated with the divider from low frequencies to high frequencies [16], see Fig. 6. The spectrum of the quantization noise  $S_{\Delta\Sigma}$  is described for  $m$ -th order  $\Delta\Sigma$  modulator as [17]:

$$S_{\Delta\Sigma}(f)[\text{rad}^2/\text{Hz}] = \frac{(2\pi)^2}{12F_{ref}} \left[ 2\sin(\pi f/F_{ref}) \right]^{2(m-1)}. \quad (9)$$

We consider the quantization noise  $S_{\Delta\Sigma}$  to be injected before the frequency divider  $N/N+1$ . Hence, the noise transfer function of the phase corresponds to the low-pass transfer function  $G_{LPF}$  as derived in equation 5. Furthermore, the noise contribution to the output of the PLL reads:

$$S_{\Delta\Sigma, out}(f) = S_{\Delta\Sigma}(f) \left| \frac{G(f)H(f)}{1+G(f)H(f)} \right|^2 = S_{\Delta\Sigma}(f) |G_{LPF}(f)|^2. \quad (10)$$

Notice the 20, 40 and 60 dB/decade slopes for the 2<sup>nd</sup>, 3<sup>rd</sup> and 4<sup>th</sup> order of the  $\Delta\Sigma$  modulator respectively. Higher  $\Delta\Sigma$  order provides better spurious suppression. Moreover, it can be seen that the  $\Delta\Sigma$  modulator of higher order contributes less quantization noise close to the carrier, but on the other hand, it adds more noise to the PLL's output at higher frequency offsets (around 12 dB difference between the 2<sup>nd</sup> and the 4<sup>th</sup> order at higher frequency offset).

#### IV. CONCLUSION

In order to meet demanding synthesizer requirements for considered standards, understanding of the phase noise behavior in PLL based synthesizers becomes critical. We have presented phase noise behavior of PLL components, including noise sources of the reference oscillator, VCO, loop filter and quantization noise of the  $\Delta\Sigma$  modulator. It has also been shown that the noise contribution of the loop filter can be reduced by means of the charge pump current optimization and by optimizing values of loop filter

components. In this particular simulation, the noise contribution was reduced by 6 dB.

Moreover, frequency synthesizer requirements of the most diffused standards in the frequency band 800 MHz to 6 GHz have been presented as well. The most challenging synthesizer design issues are dictated by GSM and WiMAX standards. More precisely, GSM standard with very straighten phase noise requirements due to large allowed interferers and WiMAX standard due to very low settling time. Due to diverse requirements of considered standards, a multiple frequency synthesizers or reconfigurable loop filter might be considered. The most promising techniques include fractional- $N$   $\Delta\Sigma$  approach which offers a significant improvement over integer- $N$  synthesizers and it provides low phase noise performance and small step size which is indispensable for future cognitive multi-radio terminals.

#### REFERENCES

- [1] Z. Xu et al., "A compact dual-band direct-conversion CMOS transceiver for 802.11a/b/g WLANs," in IEEE ISSCC Dig. Tech. Papers, Feb. 2005, pp. 98–99.
- [2] P. Zhan et al., "A single-chip dual-band direct-conversion IEEE 802.11a/b/g WLAN transceiver in 0.18- $\mu\text{m}$  CMOS," IEEE J. Solid-State Circuits, vol. 40, no. 9, pp. 1932–1939, Sep. 2005.
- [3] J. Rynnanen et al., "A single-chip multi-mode receiver for GSM900 DCS1800, PCS1900, and WCDMA," IEEE J. Solid-State Circuits, vol. 38, no. 4, pp. 594–602, Apr. 2004.
- [4] M. Brandolini et al., "Toward multistandard mobile terminals—fully integrated receivers requirements and architectures," IEEE Trans. on Microwave Theory and Techniques, vol. 53, no. 3, March 2005.
- [5] Keliu Shu and Edgar Sánchez-Sinencio, "CMOS PLL Synthesizers: Analysis and Design," Springer 2005.
- [6] Xiaopeng Li, Mohammed Ismail, "Multi-Standard CMOS Wireless Receivers, Analysis & Design," Kluwer Academic Publishers, 2002.
- [7] Y. Zhang, H. Chen, "Mobile WiMAX: Toward Broadband Wireless Metropolitan Area Networks," Auerbach Publications, 2008.
- [8] G. Cantone, "0.25  $\mu\text{m}$  802.11a WLAN front end," MuMoR Workshop, Lausanne 2004.
- [9] IEEE Standard for Local and metropolitan area networks, Part:16 Air Interface for Fixed Broadband Wireless Access Systems
- [10] Digital Cellular Telecommunications System (Phase 2): Radio Transmission and Reception, GSM Standard 05 05, 1999.
- [11] A. Koukab, Yu Lei, J. Declercq, "A GSM-GPRS/UMTS FDD-TDD/WLAN 802.11a-b-g multi-standard carrier generation system," IEEE Journal of Solid-State Circuits, vol. 41, no.7, July 2006.
- [12] G. Itkin, A. Pestravkov, "Multi-Band Frequency Synthesizer for Mobile Terminals," United States Patent no. US 6,828,836 B2, 2004.
- [13] L. Syllaios, T. Balsara, R. Staszewski, "On the reconfigurability of all-digital phase-locked loops for Software Defined Radios," The 18th Annual IEEE International Symposium on Personal, Indoor and Mobile Radio Communications (PIMRC'07).
- [14] D. Banerjee, PLL Performance, Simulation, and Design 4th Edition, 2006.
- [15] D.B. Leeson, "A simplified model of feedback oscillator noise spectrum," IEEE, Volume 42, Feb. 1965, pp. 329-33.
- [16] K. Shu et al., "A comparative study of digital  $\Sigma\Delta$  modulators for fractional-N synthesis," ICECS 2001, vol.3, Sept. 2001.
- [17] B. Miller, "A multiple modulator fractional divider," Transactions on Instrumentation and Measurements, 40, 578–583, 1991.