



HAL
open science

Asymptotics of q -Plancherel measures

Valentin Féray, Pierre-Loïc Méliot

► **To cite this version:**

| Valentin Féray, Pierre-Loïc Méliot. Asymptotics of q -Plancherel measures. 2010. hal-00446593v1

HAL Id: hal-00446593

<https://hal.science/hal-00446593v1>

Preprint submitted on 13 Jan 2010 (v1), last revised 27 Oct 2010 (v2)

HAL is a multi-disciplinary open access archive for the deposit and dissemination of scientific research documents, whether they are published or not. The documents may come from teaching and research institutions in France or abroad, or from public or private research centers.

L'archive ouverte pluridisciplinaire **HAL**, est destinée au dépôt et à la diffusion de documents scientifiques de niveau recherche, publiés ou non, émanant des établissements d'enseignement et de recherche français ou étrangers, des laboratoires publics ou privés.

ASYMPTOTICS OF q -PLANCHEREL MEASURES

VALENTIN FÉRAY AND PIERRE-LOÏC MÉLIOT

ABSTRACT. In this paper, we are interested in the asymptotic size of rows and columns of a random Young diagram under a natural deformation of the Plancherel measure coming from Hecke algebras. The first lines of such diagrams are typically of order n , so it does not fit in the context studied by P. Biane and P. Śniady. Using the theory of polynomial functions on Young diagrams of Kerov and Olshanski, we are able to compute explicitly the first- and second-order asymptotics of the length of the first rows. Our method works also for other measures, for instance those coming from Schur-Weyl representations.

1. INTRODUCTION

1.1. Background. Given a combinatorial family of planar objects, it is natural to ask if, with a good rescaling, there is a limiting continuous object when the size tends to infinity. In the case of Young diagrams endowed with Plancherel measure, this question has been solved in 1977 independently by A. Vershik and S. Kerov [KV77] and B. Logan and L. Shepp [LS77]. Then V. Ivanov and G. Olshanski [IO02], using unpublished notes of S. Kerov, have been able to describe the fluctuations of diagrams around this limit shape.

The Plancherel measure is natural when we look at Young diagrams of a given size n (whose set will be denoted \mathcal{Y}_n), because it is related to the regular representation of \mathfrak{S}_n . But there are many other interesting measures on Young diagrams and we can look for a limiting continuous object in these cases also. P. Biane has proven the existence of a limiting shape under some general conditions on the character values of the representation associated to the measure [Bia01]. This includes some natural representations, like the one on $(\mathbb{C}^N)^{\otimes n}$ appearing in Schur-Weyl duality under some conditions on n and N . In this context, the second-order asymptotics has been studied by P. Śniady [Śni06].

The results mentioned above give a limit shape for the Young diagrams rescaled by $1/\sqrt{n}$, where n is the number of boxes of the diagram. In particular, the existence of a limit shape implies that the probability that a random diagram has a long row or column (of length $\gg \sqrt{n}$) tends to 0. So it is not a good formalism to study the asymptotic behavior of non-balanced Young diagrams, such as diagrams under the q -Plancherel measure.

This measure is a natural q -analog of the Plancherel measure, and it has been introduced first by E. Strahov in [Str08]. In this paper, he looks at the asymptotic behavior of diagrams under this measure. By generalizing Kerov's method of a differential growth model [Ker96], he obtained a limit shape for a diagram under the q -Plancherel measure with a parameter q depending of the size of the diagrams.

We have mentioned above that, if we fix q , there is no hope to find a limit shape of diagrams rescaled by $1/\sqrt{n}$ as the first rows or columns are very big. In this paper, we give the precise behavior (first- and second-order asymptotics) of the length of these first rows or columns (either rows or columns, depending on the value of q , are of order $\Theta(n)$). This is a good description of the shape of the diagram as almost all the weight of the diagram lies in these rows or columns. Our method is closed to the one of the papers [IO02, Śni06].

A natural question arising after this result on q -Plancherel measure is the following. Can our method be adapted to measures for which typical diagrams have rows of intermediate scaling $\Theta(n^\alpha)$ with $1/2 < \alpha < 1$:

Key words and phrases. Asymptotics of Young diagrams, Hecke algebras, deformation of Plancherel measure.

intermediate between the balanced case ($\alpha = 1/2$) and the q -Plancherel case ($\alpha = 1$)? The answer is yes and, as examples, we look at measures associated to Schur-Weyl duality. In these cases, the method gives results on the global shape of the diagram, but not the precise behavior of the first rows and columns. Indeed, as for balanced diagrams, the asymptotic behavior of the lengths of the first rows and columns is not a direct consequence of the existence of the limit shape. For instance, in the case of the Plancherel measure, a consequent amount of extra work is needed: see [BDJ99, BDJ00, Oko00, BOO00].

1.2. Results.

1.2.1. *First rows of a random Young diagram under the q -Plancherel measure.* Let us suppose $q < 1$. In this paper, we compute the asymptotic behavior (law of large numbers and central limit theorem) of the vector containing the lengths of the first k rows of a random diagram under the q -Plancherel measure $M_{n,q}$. Note that Theorem 1 implies that the k first rows contain asymptotically $(1 - q^k) \times n$ boxes, therefore describing the length of these rows gives a good description of the diagram. As $M_{n,q^{-1}}(\lambda') = M_{n,q}(\lambda)$ (this follows from Definition 1), in the case $q > 1$, our result gives the asymptotic behavior of the columns, which are, in this case, the relevant quantities.

Theorem 1 (First order asymptotics). *Suppose $q < 1$. If $\lambda = (\lambda_1 \geq \lambda_2 \geq \dots)$ denotes a Young diagram of size n under the q -Plancherel measure (cf. figure 1), then*

$$\forall i \geq 1, \quad \frac{\lambda_i}{n} \xrightarrow{M_{n,q}} (1 - q) q^{i-1};$$

where the arrow $\xrightarrow{M_{n,q}}$ means convergence in probability.

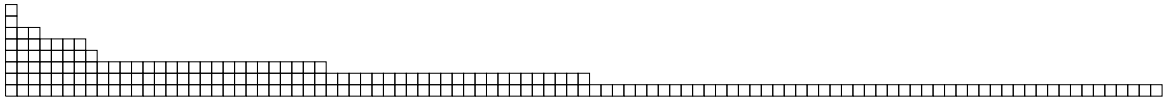

FIGURE 1. A random Young diagram $\lambda = (101, 51, 28, 8, 7, 3, 1, 1)$ of size 200 under the $1/2$ -Plancherel measure.

Theorem 2 (Second order asymptotics). *Under the same hypothesis, if $Y_{n,q,i}$ is the rescaled deviation*

$$\sqrt{n} \left(\frac{\lambda_i}{n} - (1 - q) q^{i-1} \right),$$

then we have convergence of the finite-dimensional laws of the random process $(Y_{n,q,i})_{i \geq 1}$ towards those of a gaussian process $(Y_{q,i})_{i \geq 1}$ with:

$$\mathbb{E}[Y_{q,i}] = 0 \quad ; \quad \mathbb{E}[Y_{q,i}^2] = (1 - q) q^{i-1} - (1 - q)^2 q^{2(i-1)} \quad ; \quad \text{cov}(Y_{q,i}, Y_{q,j}) = -(1 - q)^2 q^{i+j-2}.$$

In particular, two different coordinates $Y_{q,i}$ and $Y_{q,j}$ are negatively correlated. For the readers not accustomed to the topology of convergence in law, let us give a more concrete version of Theorem 2. Given $\varepsilon > 0$ and for any positive real numbers x_1, \dots, x_r , Theorem 2 ensures that, for n big enough:

$$\left| \mathbb{P} \left[\forall i \in \llbracket 1, r \rrbracket, |\lambda_i - (1 - q) q^{i-1} n| \leq x_i \sqrt{n} \right] - \frac{1}{\sqrt{(2\pi)^r \det Q}} \int_{-x_1}^{x_1} \dots \int_{-x_r}^{x_r} e^{-\frac{tXQ^{-1}X}{2}} dX \right| \leq \varepsilon,$$

where Q is the symmetric matrix with coefficients $Q_{ij} = \delta_{ij} (1 - q) q^{i-1} - (1 - q)^2 q^{i+j-2}$, which is positive definite because of the Hadamard rule (in each column, the diagonal coefficient is positive and strictly bigger than the sum of the absolute values of the other coordinates).

1.2.2. *Other measures.* As mentioned in paragraph 1.1, our method is quite general. We can establish limit shape theorems with different rescalings. As example, in paragraph 6, we introduce some natural probability measures on Young diagrams. We obtain the following result:

Theorem 3. *Let $(\lambda_n)_n$ be the sequence of random Young diagrams described in paragraph 6.1. Let us assume $N \sim c \cdot n^\alpha$ with $\alpha < 1/2$ if we rescaled λ_n by $n^{1-\alpha}$ in the horizontal direction and n^α in the vertical direction, the new sequence converges in probability towards a rectangle of side c and c^{-1} .*

More precisely, for each $\varepsilon, \eta > 0$, there exists an integer n_0 such that, for each $n \geq n_0$, the border of the diagram λ_n is, after rescaling and with probability greater than $1 - \varepsilon$, contained in the hatched area:

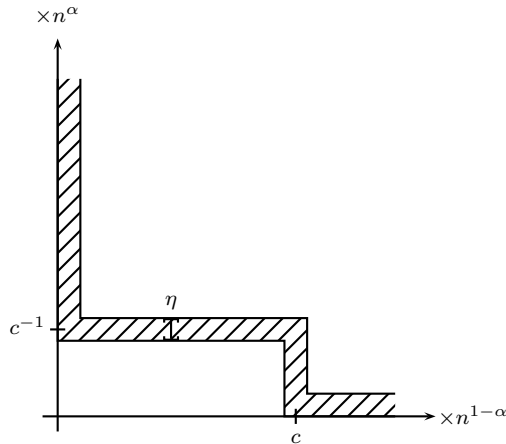

FIGURE 2. Limit shape of a rescaled random diagram under the Schur-Weyl measure of parameters $c > 0$ and $\alpha < 1/2$.

Unfortunately, one can not use this to give the precise behavior of the first row of the diagram. The only result we have is the following one (which is a consequence of Proposition 22):

Proposition 4. *Let λ_n be the sequence of random diagrams described in paragraph 6.1. Let us assume that $N \sim c n^\alpha$ with $\alpha < 1/2$. For any $\varepsilon > 0$, one has $\lambda_1 = o(n^{1-\alpha+\varepsilon})$ in probability.*

1.2.3. *Longest increasing subsequence.* It is well-known that the length of the first row of a Young diagram of size n under Plancherel measure has the same distribution as the length of the longest increasing subsequence of a random permutation of size n (under the uniform distribution). Indeed, the shape of the tableaux obtained by Robinson-Schensted bijection defines a map

$$\mathfrak{S}_n \longrightarrow \{\lambda \vdash n\},$$

which sends the length of the longest increasing subsequence on the length of the first row of λ . The image of the uniform distribution on \mathfrak{S}_n is the Plancherel measure on Young diagrams of size n , and this explains the aforementioned result.

Our results on the q -Plancherel measure can also be interpreted in the context of longest increasing subsequences. Indeed, E. Strahov [Str08] has noticed that the q -Plancherel measure is the image by the map above of the probability measure defined by

$$\forall \sigma, \mathbb{P}[\sigma] = Z \cdot q^{\text{imaj}(\sigma)},$$

where $\text{imaj}(\sigma)$, called major index, is the sum of the positions of the descents of σ and $Z = 1/[n]_q!$ is the normalization constant such that the probabilities sum to 1. So Theorems 1 and 2 imply the following result:

Theorem 5. *Let q be a real in $]0, 1[$ and n an integer. Consider the distribution on permutations such that the probability to pick a permutation σ is proportional to $q^{\text{maj}(\sigma)}$. The length $\ell(\sigma)$ of the longest increasing subsequence of a permutation under this distribution is equivalent in probability to $n(1 - q)$. Moreover, the rescaled deviation $(\ell(\sigma) - n(1 - q))/\sqrt{n}$ converges in law towards a centered normal law of variance $(1 - q) - (1 - q)^2$.*

As mentioned in subsection 6.1, the measure considered in section 6 is the image of the uniform distribution on words of length n with letters from 1 to N by RSK algorithm. Therefore Proposition 4 implies:

Corollary 6. *Fix $c > 0$ and $0 < \alpha < 1/2$. Let ℓ be the length of the longest non-decreasing subsequence of a random word with n letters between 1 and $c \cdot \lfloor n^\alpha \rfloor$. When n tends to infinity, one has in probability: $\ell = o(n^{1-\alpha+\varepsilon})$.*

1.3. Tools. Since we are looking at measures on diagrams of a given size, irreducible character values on a given permutation can be seen as random variables. Moreover, in our context, their expectations are easy to compute. Therefore we would like to express other random variables, linked directly to the shape of the diagrams in terms of the character value. This can be done thanks to Kerov's and Olshanski's theory of polynomial functions on the set of Young diagrams (see [KO94]). Note that the general idea described here is already the one used by Kerov for his central limit theorem (see [IO02]).

In this article, we shall use the power sums of Frobenius coordinates. With an adequate gradation on the functions on Young diagrams, we shall easily find their asymptotic behavior under the q -Plancherel measure. Going back to the behavior of the first rows is then a technical step.

1.4. Some open questions.

1.4.1. Precise behavior of the first line. Proposition 4 (respectively Corollary 6) gives only an upper bound for the behavior of the first row of the considered diagrams (respectively the length of the longest non-decreasing subsequence of a random word). It would be nice to obtain the precise behavior (equivalent and perhaps fluctuation) of these random variables. If we follow [Ok00], the first step is to study the asymptotic behavior of the observable p_k with a parameter k which tends also to infinity (as quickly as some power of n for example). Such a result could be deduced from the expression p_ρ in terms of Σ 's (normalized characters), but unfortunately, equation (2) is hard to invert.

1.4.2. Concrete realization of power sums in the center of the symmetric group algebras. We will see in section 3 that the relations between some functions on Young diagrams can be understood as relations in the center of the symmetric group algebras via the abstract Fourier transform. Therefore, if we want to understand better the expression of the p_ρ 's in terms of the Σ 's (and we would like to, see the first open problem!), one way to do it would be to describe in a nice way the image of the p_ρ 's by the abstract Fourier transform. One could also use the power sums of Jucys-Murphy elements which have a simple definition in $\mathbb{C}\mathfrak{S}_n$ and have the same top homogeneous component as the p_ρ (with a shift of index and up to a multiplicative constant).

1.5. Outline of the paper. In section 2, we define the q -Plancherel measure and recall its basic properties. Then, in section 3, we introduce families of observables of diagrams, which will be useful in the proof of the main theorems. Sections 4 and 5 are respectively devoted to the proofs of Theorems 1 and 2. In section 6, we study other measures with the same tools.

2. THE q -PLANCHEREL MEASURE

In this section, we define and present basic properties of the q -Plancherel measure. The characterization given in paragraph 2.2 is the one which will be used in the next sections. The algebraic interpretation of paragraph 2.3 gives some motivation to look at this measure.

2.1. Definition.

Definition 1. *The q -Plancherel measure on the set \mathcal{Y}_n of Young diagrams of size n is the probability measure $M_{n,q}$ defined by:*

$$\forall \lambda \vdash n, M_{n,q}(\{\lambda\}) = M_{n,q}(\lambda) = \frac{D_\lambda(q) \dim \lambda}{\{n!\}_q},$$

where $\dim \lambda$ is the dimension of the irreducible representation of \mathfrak{S}_n indexed by λ , and $D_\lambda(q)$ is its generic degree defined in [GP00, Chapter 8].

This is a natural q -analog of the Plancherel measure defined by E. Strahov [Str08] (for instance, it could also be defined by a Markov process which generalizes the Plancherel growth process, see figure 3). In the two next paragraphs, we shall explain why this q -analog is natural in the context of Hecke algebras and general linear groups in finite characteristic.

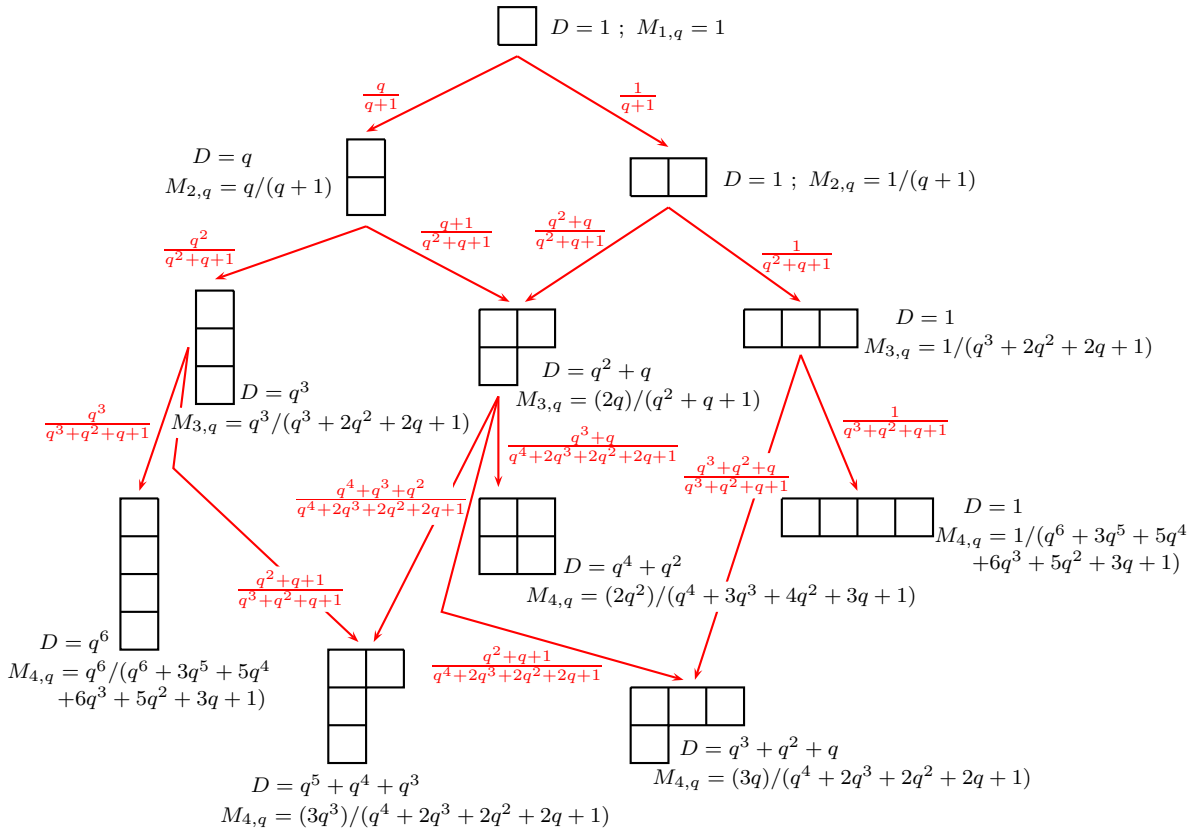

FIGURE 3. Generic degrees, q -Plancherel measures and q -transition probabilities on diagrams of size $n \leq 4$.

2.2. Link with representation of the Hecke algebras. The q -Plancherel measure appears naturally in the abstract harmonic analysis of the Iwahori-Hecke algebras $\mathcal{H}_{n,q}$. Recall that if $n \in \mathbb{N}$ and q is a complex parameter, then $\mathcal{H}_{n,q}$ is the complex associative algebra with generators T_1, T_2, \dots, T_{n-1} and relations:

$$\begin{aligned} \text{braid relations: } & \forall i, T_i T_{i+1} T_i = T_{i+1} T_i T_{i+1}; \\ \text{commutation relations: } & \forall |j - i| \geq 2, T_i T_j = T_j T_i; \\ \text{quadratic relations: } & \forall i, (T_i - q)(T_i + 1) = 0. \end{aligned}$$

We recover the symmetric group algebra $\mathbb{C}\mathfrak{S}_n$ for $q = 1$. For any value of q , one can define an element corresponding to a permutation $\sigma \in \mathfrak{S}_n$:

$$T_\sigma = T_{i_1} T_{i_2} \dots T_{i_k},$$

where $\sigma = s_{i_1} s_{i_2} \dots s_{i_k}$ is a minimal decomposition of σ in elementary transpositions (thanks to the Matsumoto theorem, the result does not depend on which minimal decomposition we choose). It can be shown that $(T_\sigma)_{\sigma \in \mathfrak{S}_n}$ forms a linear basis of $\mathcal{H}_{n,q}$ (see for example [Mat99] or [GP00]). Moreover, if $q \neq 0$ is not a root of unity (in the following, we assume that we are in this case, as q is a positive real number), then $\mathcal{H}_{n,q}$ is a semi-simple algebra abstractly isomorphic to $\mathbb{C}\mathfrak{S}_n$, and have consequently the same theory of representations: the irreducible $\mathcal{H}_{n,q}$ -modules are parameterized by the partitions of size n , and each Specht module $S^\lambda(q)$ has for dimension

$$\dim S^\lambda(q) = \dim S^\lambda = \frac{n!}{\prod_{(i,j)} h(i,j)} \quad (\text{hook length formula}).$$

We will denote by $\zeta^\lambda(q)$ the trace of the simple module $S^\lambda(q)$, and by $\chi^\lambda(q)$ the *normalized* character, so that $\zeta^\lambda(q) = (\dim \lambda) \chi^\lambda(q)$. Both objects are central linear forms on $\mathcal{H}_{n,q}$.

Let us consider the regular trace of the Iwahori-Hecke algebra:

$$\tau_q(T_\sigma) = \begin{cases} 1 & \text{if } \sigma = \text{id}, \\ 0 & \text{otherwise.} \end{cases}$$

The decomposition of τ_q in the basis of normalized q -characters $\chi^\lambda(q)$ writes as:

$$(1) \quad \tau_q = \sum_{\lambda \in \mathcal{P}_n} M_{n,q}(\lambda) \chi^\lambda(q) = \sum_{\lambda \in \mathcal{P}_n} \frac{D_\lambda(q)}{\{n!\}_q} \zeta^\lambda(q)$$

Of course, this characterizes the Plancherel measure. Therefore, if we consider the q -characters on a fixed element T_σ as a function of the indexing partition λ , its expectation under the q -Plancherel measure is $\tau_q(T_\sigma)$, that is either 0 or 1. Using this, we will be able to compute expectations of observables of diagrams.

Remark 1. We will prove in this article that we have in fact a concentration of the q -characters around the regular trace, see Corollary 13.

2.3. Interpretation in the representation theory of $\text{GL}_n(\mathbb{F}_q)$. If $q = p^e$ is a power of a prime number, the previous identities may be interpreted in the setting of the representation theory of the group of invertible $n \times n$ matrices $\text{GL}(n, \mathbb{F}_q)$. Indeed, it is a well-known fact [Iwa64] that the relations defining $\mathcal{H}_{n,q}$ are those of the convolution algebra

$$\mathbb{C}[\text{B}(n, \mathbb{F}_q) \backslash \text{GL}(n, \mathbb{F}_q) / \text{B}(n, \mathbb{F}_q)] = \{f \in \mathbb{C}[\text{GL}(n, \mathbb{F}_q)] \mid \forall b, b' \in \text{B}(n, \mathbb{F}_q), f(bgb') = f(g)\},$$

where $\text{B}(n, \mathbb{F}_q)$ is the Borel subgroup of $\text{GL}(n, \mathbb{F}_q)$, containing the invertible upper-triangular matrices.

Now, consider the $\text{GL}(n, \mathbb{F}_q)$ -module of functions on the flag variety $\text{GL}(n, \mathbb{F}_q) / \text{B}(n, \mathbb{F}_q)$ — or, in other words, right $\text{B}(n, \mathbb{F}_q)$ -invariant complex functions on $\text{GL}(n, \mathbb{F}_q)$. Since $\text{GL}(n, \mathbb{F}_q)$ acts transitively

on the flag variety, a $\mathrm{GL}(n, \mathbb{F}_q)$ -endomorphism u of this module is entirely determined by a function $h \in \mathbb{C}[\mathrm{GL}(n, \mathbb{F}_q)]$ such that:

$$u(\mathbb{1}_{\mathrm{B}(n, \mathbb{F}_q)}) = \sum_{g \in G} h(g) \mathbb{1}_g.$$

Moreover, the condition $u \in \mathrm{End}_{\mathrm{GL}(n, \mathbb{F}_q)} \mathbb{C}[\mathrm{GL}(n, \mathbb{F}_q)/\mathrm{B}(n, \mathbb{F}_q)]$ implies that h is left and right $\mathrm{B}(n, \mathbb{F}_q)$ -invariant. As a consequence, we have an isomorphism

$$\mathcal{H}_{n,q} \stackrel{\mathrm{iso}}{\simeq} \mathbb{C}[\mathrm{B}(n, \mathbb{F}_q) \backslash \mathrm{GL}(n, \mathbb{F}_q) / \mathrm{B}(n, \mathbb{F}_q)] \stackrel{\mathrm{iso}}{\simeq} \mathrm{End}_{\mathrm{GL}(n, \mathbb{F}_q)} \mathbb{C}[\mathrm{GL}(n, \mathbb{F}_q) / \mathrm{B}(n, \mathbb{F}_q)],$$

whence a decomposition of the $(\mathrm{GL}(n, \mathbb{F}_q), \mathcal{H}_{n,q})$ -bimodule $\mathbb{C}[\mathrm{GL}(n, \mathbb{F}_q) / \mathrm{B}(n, \mathbb{F}_q)]$ similar to the classical Schur-Weyl duality between $\mathrm{GL}(n, \mathbb{C})$ and \mathfrak{S}_n :

$$\mathrm{GL}(n, \mathbb{F}_q) \curvearrowright \{ \mathbb{C}[\mathrm{GL}(n, \mathbb{F}_q) / \mathrm{B}(n, \mathbb{F}_q)] \} \curvearrowleft \mathcal{H}_{n,q} = \sum_{\lambda \in \mathcal{Y}_n} U_\lambda(q) \otimes_{\mathbb{C}} S^\lambda(q).$$

The $U_\lambda(q)$ are called unipotent modules of $\mathrm{GL}(n, \mathbb{F}_q)$. Each $U_\lambda(q)$ is irreducible and of complex dimension

$$\dim U_\lambda(q) = D_\lambda(q) = q^{b(\lambda)} \frac{\{n!\}_q}{\prod_{(i,j) \in \lambda} \{h(i,j)\}_q},$$

where $b(\lambda) = \sum_i (i-1)\lambda_i$. Thus, the natural probability measure $M_{n,q}$ on the set of characters of $\mathcal{H}_{n,q}$ is also the natural probability measure on the set of unipotent characters of $\mathrm{GL}(n, \mathbb{F}_q)$. Moreover, the regular trace τ_q is just the restriction of the normalized trace of $\mathrm{End}_{\mathbb{C}} \mathbb{C}[\mathrm{GL}(n, \mathbb{F}_q) / \mathrm{B}(n, \mathbb{F}_q)]$ to the subalgebra of $\mathrm{GL}(n, \mathbb{F}_q)$ -morphisms, that is to say, $\mathcal{H}_{n,q}$.

3. OBSERVABLES OF DIAGRAMS

In this section, we introduce the algebra of observables of diagrams \mathcal{O} . This subalgebra of the algebra of functions on the set of all Young diagrams $\mathcal{Y} = \bigsqcup_{n \in \mathbb{N}} \mathcal{Y}_n$ is isomorphic to the algebra of (complex) symmetric functions, and it is known to be a powerful tool in the setting of asymptotic representation theory of symmetric groups, see [IO02]. In this paper, the authors introduced four algebraic basis of \mathcal{O} : the power sums $(p_k)_{k \geq 1}$ in the Frobenius coordinates, the power sums $(\tilde{p}_k)_{k \geq 2}$ in the interlacing coordinates, the normalized characters $(\Sigma_k)_{k \geq 1}$ and the free cumulants $(R_k)_{k \geq 2}$. In the following, we shall use the power sums p_k , the normalized characters Σ_k and their quantizations $\Sigma_{k,q}$; this section is devoted to their presentation.

3.1. Power sums of Frobenius coordinates. If λ is a partition of size n , we recall that its Frobenius coordinates $(a_i, b_i)_{1 \leq i \leq d}$ are defined by $a_i = \lambda_i - i$ and $b_i = \lambda_i' - i$, with i less than the size d of the diagonal of the diagram. The modified Frobenius coordinates are $(A_\lambda, \overline{B}_\lambda) = ((a_i^*)_{1 \leq i \leq d}, (-b_i^*)_{1 \leq i \leq d})$ with $a_i^* = a_i + 1/2$ and $b_i^* = b_i + 1/2$, see figure 4 on the next page. Let us define the function p_k on the set \mathcal{Y} of all Young diagrams: $p_k(\lambda)$ is the k -th power sum of the alphabet $A_\lambda - \overline{B}_\lambda$ (with the notations of λ -rings). In other words,

$$p_k(\lambda) = \sum_{i=1}^d (a_i^*)^k - (-b_i^*)^k.$$

Note that $p_1(\lambda)$ is simply the size $|\lambda|$ of the diagram (whence the modification of the coordinates).

We denote by \mathcal{O} the algebra generated by the functions $(p_k)_{k \geq 1}$; it is the algebra of polynomial functions on Young diagrams introduced by S. Kerov and G. Olshanski in [KO94], but we use here the notations of [IO02]. It can be shown that the p_k are algebraically independent over \mathbb{C} , and as a consequence, the $p_\rho = p_{\rho_1} p_{\rho_2} \cdots p_{\rho_r}$ (where ρ runs over all partitions) form a linear basis of \mathcal{O} . The algebra of observables of diagrams has therefore a canonical gradation given by:

$$\deg p_\rho = |\rho| = \rho_1 + \rho_2 + \cdots + \rho_r.$$

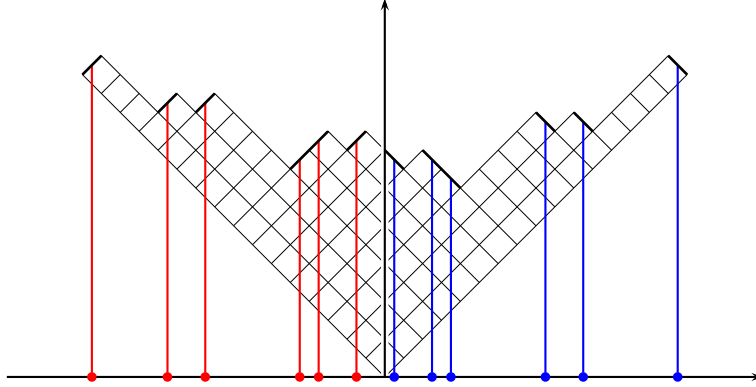

FIGURE 4. Modified Frobenius coordinates of a Young diagram drawn in Russian style. For instance, a_1^* is here equal to $31/2$, and $-b_2^* = -23/2$.

3.2. Normalized characters. Another graded algebraic basis may be considered: the normalized characters $(\Sigma_k)_{k \geq 1}$. If ρ and λ are two partitions of respective sizes k and n , we define the following function on \mathcal{Y} :

$$\Sigma_\rho(\lambda) = \begin{cases} n^{\downarrow k} \chi^\lambda(\sigma_\rho 1^{n-k}) & \text{if } k \leq n \\ 0 & \text{if } k > n, \end{cases}$$

where $n^{\downarrow k} = n(n-1) \cdots (n-k+1)$ is the k -th falling factorial of n , the partition $\rho' = \rho 1^{n-k}$ is the partition ρ completed with parts of size 1, and $\sigma_{\rho'}$ is any permutation in \mathfrak{S}_n with cycle decomposition of type ρ' .

In the case where λ has only one part (character values on cycles), by using the Frobenius formula $\zeta^\lambda(\rho) = \langle s_\lambda | p_\rho \rangle$ (cf. [Mac95, §1.7], and in particular the corollary 1.7.7), it can be shown that Σ_k is a polynomial in the $(p_l)_{l \leq k}$. To compute these polynomials, one can use the following Proposition (see [IO02, Propositions 3.3 and 3.4, 4.4 and 4.5]):

Proposition 7. *If $k \geq 1$, the observable Σ_k writes as*

$$(2) \quad \Sigma_k = [t^{k+1}] \left\{ -\frac{1}{k} \prod_{j=1}^k (1 - (j-1/2)t) \cdot \exp \left(\sum_{j=1}^{\infty} \frac{p_j t^j}{j} (1 - (1-kt)^{-j}) \right) \right\}.$$

As a consequence, the top homogeneous component of Σ_k is p_k , and $(\Sigma_k)_{k \geq 1}$ is a algebraic basis of the algebra \mathcal{O} .

Examples 1. $\Sigma_1 = p_1$, $\Sigma_2 = p_2$, $\Sigma_3 = p_3 - \frac{3}{2}p_{11} + \frac{5}{4}p_1$, $\Sigma_4 = p_4 - 4p_{21} + \frac{11}{2}p_2$.

By abstract Fourier transform $Z(\mathbb{C}\mathfrak{S}_n) \leftrightarrow \mathbb{C}\mathfrak{S}_n^\vee = \mathbb{C}\mathcal{Y}_n$, we may interpret a function on Young diagrams with n boxes as an element of the center of the group algebra $\mathbb{C}\mathfrak{S}_n$. Thus a function f on all Young diagrams can be seen as sequences of elements $(f_n)_{n \geq 1}$ with $f_n \in Z(\mathbb{C}\mathfrak{S}_n)$ for all n . In the case of the normalized characters Σ_ρ , this sequence has a very nice expression, see [Śni06]:

$$(3) \quad \begin{aligned} (\Sigma_{\rho_1, \rho_2, \dots, \rho_r})_n &= \sum_{\substack{a_{(i,j)} \in [1, n] \\ a_{i,j} \neq a_{(i,j)'}}} (a_{11}, a_{12}, \dots, a_{1\rho_1}) (a_{21}, a_{22}, \dots, a_{2\rho_2}) \cdots (a_{r1}, a_{r2}, \dots, a_{r\rho_r}) \\ &= \sum_{\substack{\forall i, A_i \in \mathcal{A}(n, \rho_i) \\ \forall i \neq j, A_i \cap A_j = \emptyset}} C(A_1) C(A_2) \cdots C(A_r), \end{aligned}$$

where $\mathcal{A}(n, k)$ is the set of k -arrangements of $\llbracket 1, n \rrbracket$ and $C(A)$ is the cycle corresponding to a sequence A of distinct numbers. It is easy to check that these elements verify

$$\forall \lambda \in \mathcal{Y}, \quad \Sigma_\rho(\lambda) = \chi^\lambda((\Sigma_\rho)_{|\lambda|}).$$

Hence, the element in the equation (3) corresponds to the function Σ_ρ on Young diagrams by the abstract Fourier transform, so the notation are coherent. Moreover, formula (3) allows to do computations for all n simultaneously and in this case, we will forget the index n (for example in next paragraph).

3.3. Products of normalized characters. As abstract Fourier transform is a ring homomorphism, the convolution product in the center of the symmetric group algebra corresponds to the point-wise multiplication of functions over Young diagrams of size n . But, in $Z(\mathbb{C}\mathfrak{S}_n)$, one has

$$\Sigma_\mu \cdot \Sigma_\nu = \sum_{\substack{\forall i, A_i \in \mathcal{A}(n, \mu_i) \\ \forall i \neq j, A_i \cap A_j = \emptyset}} \sum_{\substack{\forall i, B_i \in \mathcal{A}(n, \nu_i) \\ \forall i \neq j, B_i \cap B_j = \emptyset}} C(A_1) C(A_2) \cdots C(A_r) C(B_1) C(B_2) \cdots C(B_r).$$

As the A_i 's and the B_j 's may have elements in common, this is not equal to $\Sigma_{\mu \cup \nu}$. Let us split this double summation over $a_{i,j}$ and $b_{k,l}$ in the following way. To each indexing sequence $a_{i,j}, b_{k,l}$, we associate the partial matching between the sets $I_A = (i, j)_{1 \leq j \leq \mu_i}$ (indices of the a 's) and $I_B = (k, l)_{1 \leq l \leq \nu_i}$, which links (i, j) and (k, l) if and only if $a_{i,j} = b_{k,l}$. When we sum the quantity

$$(4) \quad C(A_1) C(A_2) \cdots C(A_r) C(B_1) C(B_2) \cdots C(B_r)$$

over indexing sequences with a given partial matching, we obtain Σ_ρ for some ρ depending on the matching. Indeed, if we know which of the $a_{i,j}$'s are equal to which of the $b_{k,l}$'s, the product (4) can be rewritten as a product of cycles with disjoint supports in a way which does not depend of the values of the a 's and of the b 's. Finally,

$$\Sigma_\mu \cdot \Sigma_\nu = \sum \Sigma_{\rho(M)},$$

where the sum runs over partial matchings M of the set of indices of the a 's with the set of indices of the b 's.

Example 2. Let us compute $\Sigma_2 \cdot \Sigma_3$. The set of indices of the a 's (resp. the b 's) is $\{1, 2\}$ (resp. $\{1, 2, 3\}$).

- If A and B have no common element, the product $C(A) C(B)$ is a 3-cycle multiplied by a 2-cycle with disjoint supports and the corresponding sum is $\Sigma_{3,2}$.
- If $a_1 = b_1$, but all other elements are different, then $(a_1 a_2 a_3) \cdot (a_1 b_2) = (a_1 b_2 a_2 a_3)$. When we sum on all possible values of a_1, b_2, a_2, a_3 (all different), one obtains Σ_4 .
The result is the same for any of the 6 matchings of size 1.
- If $a_1 = b_1$ and $a_2 = b_2$, then $(a_1, a_2, a_3) \cdot (a_1, a_2) = (a_1, a_3)(a_2)$. When we sum on all possible values of a_1, a_2, a_3 , one obtains $\Sigma_{2,1}$ (note, that here it is important to remember that we have to sum over indices a_2 even if its value does not change the permutation).

Once again, the result is the same for any of the 6 matchings of size 2.

Thus, $\Sigma_2 \cdot \Sigma_3 = \Sigma_{2,3} + 6\Sigma_4 + 6\Sigma_{2,1}$.

In general, one has the following properties:

- (1) The size of $\rho(M)$ is simply $|\mu| + |\nu| - |M|$ where $|M|$ is the size of the matching.
- (2) The term corresponding to the empty matching is $\Sigma_{\nu \cup \mu}$. Thus,

$$\Sigma_\nu \cdot \Sigma_\mu = \Sigma_{\nu \cup \mu} + \sum_{|\rho| < |\mu| + |\nu|} c_{\nu, \mu}^\rho \Sigma_\rho.$$

By induction, one obtains that, if $k_1 \geq k_2 \geq \dots \geq k_r$:

$$\Sigma_{k_1} \cdot \Sigma_{k_2} \cdots \Sigma_{k_r} = \Sigma_{k_1, \dots, k_r} + \sum_{|\rho| < k_1 + \dots + k_r} c_{k_1, \dots, k_r}^\rho \Sigma_\rho.$$

This triangular relation can be inverted, so the Σ_ρ are in the algebra \mathcal{O} and span it linearly. Moreover, Σ_ρ is a non-homogeneous element of degree $|\rho|$ and its homogeneous component of maximal degree is p_ρ .

- (3) If $\mu = (l)$ and $\nu = (m)$, all matchings of size 1 give a term Σ_{l+m-1} . As they are ml such matchings, one has

$$\Sigma_l \Sigma_m = \Sigma_{l,m} + ml \Sigma_{l+m-1} + (\text{terms of degree at most } l + m - 2).$$

3.4. Another product. In this paragraph, we recall the definition of the disjoint product \bullet on \mathcal{O} (see [Śni06]), which will be useful in section 5. It is enough to give the value of the product of two elements of the basis Σ_ρ :

$$\Sigma_\mu \bullet \Sigma_\nu = \Sigma_{\mu \sqcup \nu}.$$

If we look at the description of the classical product on the Σ_μ given at the previous paragraph, taking the product \bullet consists in keeping in the result the terms indexed by families of disjoint indices. This remark can be generalized to expression of the kind:

$$X_{i_1, \dots, i_r}^{\mathcal{G}} = \sum_{\substack{\forall j, A_j \in \mathcal{A}(n, i_j) \\ G(a_{i,j}) \in \mathcal{G}}} C(A_1) \cdots C(A_r),$$

where $G(a_{i,j})$ is, as in the previous paragraph, the graph describing which of the $a_{i,j}$'s are equal and \mathcal{G} a collection of *admissible* graphs. The following lemma will be useful in subsection 5.1:

Lemma 8. *The disjoint product of two such expressions is given by:*

$$X_{i_1, \dots, i_r}^{\mathcal{G}} \bullet X_{i'_1, \dots, i'_r}^{\mathcal{G}'} = X_{i_1, \dots, i_r, i'_1, \dots, i'_r}^{\mathcal{G} \sqcup \mathcal{G}'},$$

where $\mathcal{G} \sqcup \mathcal{G}'$ is the collection of all graphs obtained by disjoint union of a graph of \mathcal{G} and a graph of \mathcal{G}' . In other words, the disjoint product of two expressions as above is obtained by keeping in the usual product only terms such that the two families of indices are disjoint.

Proof. As in the previous paragraph, the summation over sequences of indices corresponding to a given graph gives a term Σ_ρ . Therefore:

$$X_{i_1, \dots, i_r}^{\mathcal{G}} = \sum_{G \in \mathcal{G}} \Sigma_{\rho(G)}$$

and we have

$$\begin{aligned} X_{i_1, \dots, i_r}^{\mathcal{G}} \bullet X_{i'_1, \dots, i'_r}^{\mathcal{G}'} &= \sum_{G \in \mathcal{G}} \sum_{G' \in \mathcal{G}'} \Sigma_{\rho(G), \rho(G')}; \\ &= X_{i_1, \dots, i_r, i'_1, \dots, i'_r}^{\mathcal{G} \sqcup \mathcal{G}'}. \end{aligned} \quad \square$$

3.5. q -characters. In this paragraph, we present a quantization of the Σ -basis of \mathcal{O} corresponding to renormalized q -characters of the Iwahori-Hecke algebras. In [Ram91], A. Ram uses the Schur-Weyl decomposition of $(\mathbb{C}^m)^{\otimes n}$ in irreducible $(U_q(\mathfrak{sl}(m, \mathbb{C})), \mathcal{H}_{n,q})$ -bimodules to compute explicitly the characters of the Iwahori-Hecke algebra $\mathcal{H}_{n,q}$ — the reader can also consult [RRW96] and [RR97]. These computations lead to a generalization of the usual Frobenius-Schur formula. Recall that the latter writes as:

$$\forall \rho \in \mathcal{Y}_n, \quad p_\rho(X) = \sum_{\lambda \in \mathcal{Y}_n} \zeta^\lambda(\rho) s_\lambda(X).$$

First, we need a q -analog of the character value $\zeta^\lambda(\rho)$. Given two permutations σ and τ in the same conjugacy class of \mathfrak{S}_n , the T -basis elements T_σ and T_τ can have different traces in a $\mathcal{H}_{n,q}$ -module: for instance, $(1, 2)$ and $(1, 3)$ are conjugate in \mathfrak{S}_3 , but $\chi(T_{(1,2)}) = q$ and $\chi(T_{(1,3)}) = q^3$ if we consider the one-dimensional index representation. However, if σ and τ are of minimal Coxeter length in their conjugacy classes, then one has $\chi(T_\sigma) = \chi(T_\tau)$ for any character χ . Moreover, the values of a character χ on these particular elements determine χ , see [Ram91, Propositions 5.1 and 5.2] or [GP00, §8.2] for the general case of an Iwahori-Hecke algebra of a Coxeter group. Consequently, if

$$\sigma_\rho = (1, 2, \dots, \rho_1) (\rho_1 + 1, \rho_1 + 2, \dots, \rho_1 + \rho_2) \cdots (\rho_1 + \cdots + \rho_{r-1} + 1, \dots, \rho_1 + \cdots + \rho_r),$$

then $\zeta^\lambda(q)$ is entirely determined by the values $\zeta^\lambda(\rho, q) = \zeta^\lambda(T_{\sigma_\rho}, q)$, where ρ runs over \mathcal{Y}_n . As in the case $q = 1$, we denote by $\chi^\lambda(\rho, q)$ the rescaled character value (divided by the dimension of the module).

We shall also need a q -analog of the power sum $p_k(X)$. Let $\tilde{q}_k(X, q)$ be the symmetric function defined by the formulas

$$\begin{aligned}\tilde{q}_k(X, q) &= \frac{q^k}{q-1} h_k(X(1-q^{-1})) \quad (\lambda\text{-ring notations, } X \text{ is an alphabet and } q^{-1} \text{ is a variable),} \\ &= \frac{q^k}{q-1} \sum_{\mu \in \mathcal{Y}_k} (1-q^{-1})^{\ell(\mu)} m_\mu(X) = \frac{1}{q-1} \sum_{\mu \in \mathcal{Y}_k} (q^\mu - 1)(z_\mu)^{-1} p_\mu(X),\end{aligned}$$

where $q^\mu - 1$ means $\prod_{i=1}^r (q^{m_i} - 1)$, and where z_μ equals $\prod_{i \geq 1} i^{m_i} m_i!$ if μ writes multiplicatively as $1^{m_1} 2^{m_2} \dots s^{m_s}$. This is a slightly modified version of the Hall-Littlewood polynomial $P_k(X, q^{-1})$ described in [Mac95, Chapter 3]. We can now state Ram's generalization of Frobenius-Schur formula:

Proposition 9 (q -Frobenius-Schur formula). *If $\tilde{q}_\rho = \tilde{q}_{\rho_1} \cdots \tilde{q}_{\rho_r}$, then the following generalized Frobenius-Schur formula holds:*

$$\forall \rho \in \mathcal{Y}_n, \quad \tilde{q}_\rho(X, q) = \sum_{\lambda \in \mathcal{Y}_n} \zeta^\lambda(\rho, q) s_\lambda(X).$$

Many combinatoric rules follow from Proposition 9, *e.g.*, a quantization of the classical Murnaghan-Nakayama rule, see [RR97, §2]. For the asymptotic analysis of the q -Plancherel measures, we shall use a triangular relation between q -characters and standard characters:

$$\begin{aligned}\zeta^\lambda(\rho, q) &= \langle \tilde{q}_\rho(X, q) | s_\lambda(X) \rangle = \frac{q^n}{(q-1)^{\ell(\rho)}} \langle h_\rho(X - q^{-1}X) | s_\lambda(X) \rangle \\ &= \frac{q^n}{(q-1)^{\ell(\rho)}} \sum_{\nu \in \mathcal{Y}_n} \frac{\langle h_\rho(X - q^{-1}X) | p_\nu(X - q^{-1}X) \rangle \langle p_\nu(X - q^{-1}X) | s_\lambda(X) \rangle}{\langle p_\nu | p_\nu \rangle} \\ &= \frac{1}{(q-1)^{\ell(\rho)}} \sum_{\nu \in \mathcal{Y}_n} (q^\nu - 1) \frac{\langle h_\rho | p_\nu \rangle}{z_\nu} \langle p_\nu | s_\lambda \rangle = \frac{1}{(q-1)^{\ell(\rho)}} \sum_{\nu \in \mathcal{Y}_n} \frac{q^\nu - 1}{z_\nu} \langle h_\rho | p_\nu \rangle \zeta^\lambda(\nu)\end{aligned}$$

As for $q = 1$, we define the following function on the set \mathcal{Y} of all Young diagrams:

$$\Sigma_{\rho, q}(\lambda) = \begin{cases} |\lambda|^{\downarrow|\rho|} \chi^\lambda(\rho 1^{|\lambda|-|\rho|}, q) & \text{if } |\rho| \leq |\lambda|; \\ 0 & \text{else.} \end{cases}$$

If $|\rho| = |\lambda| = n$, the previous formula can be rewritten:

$$(5) \quad (q-1)^{\ell(\rho)} \Sigma_{\rho, q}(\lambda) = \sum_{\nu \in \mathcal{Y}_n} \frac{q^\nu - 1}{z_\nu} \langle p_\nu | h_\rho \rangle \Sigma_\nu(\lambda)$$

This is of course also true for $|\rho| > |\lambda|$. We will show that it still holds for $k = |\rho| < |\lambda| = n$. In this case, the scalar product $\langle h_{\rho 1^{n-k}} | p_\nu \rangle$ in the sum above writes as:

$$\begin{aligned}\langle h_{\rho 1^{n-k}} | p_\nu \rangle &= \langle h_\rho(p_1)^{n-k} | p_\nu \rangle = \sum_{\pi_1 \in \mathcal{Y}_{\rho_1}, \dots, \pi_m \in \mathcal{Y}_{\rho_m}} (z_{\pi_1} \cdots z_{\pi_m})^{-1} \langle p_\pi(p_1)^{n-k} | p_\nu \rangle \\ &= \sum_{\pi_1, \dots, \pi_m} z_{\pi_1}^{n-k} (z_{\pi_1} \cdots z_{\pi_m})^{-1} \mathbb{1}_{(\nu = \pi_1^{n-k})} = (z_\nu \mathbb{1}_{(\nu = \nu_k 1^{n-k})}) \sum_{\pi_1, \dots, \pi_m} (z_{\pi_1} \cdots z_{\pi_m})^{-1} \mathbb{1}_{(\nu_k = \pi)} \\ &= (z_\nu / z_{\nu_k}) \mathbb{1}_{(\nu = \nu_k 1^{n-k})} \sum_{\pi_1, \dots, \pi_m} (z_{\pi_1} \cdots z_{\pi_m})^{-1} \langle p_\pi | p_{\nu_k} \rangle = (z_\nu / z_{\nu_k}) \mathbb{1}_{(\nu = \nu_k 1^{n-k})} \langle h_\rho | p_{\nu_k} \rangle\end{aligned}$$

As a consequence, formula (5) can be seen as an equality of functions on \mathcal{Y} . Note that this relation between the symbols $\Sigma_{\rho, q}$ and Σ_ν is triangular, because $\langle p_\nu | h_\rho \rangle = 0$ unless ν is finer than ρ . Moreover, as $(m_\rho)_{\rho \in \mathcal{Y}}$ is the dual basis of $(h_\rho)_{\rho \in \mathcal{Y}}$, the inverse relation is easily obtained. We conclude that:

Proposition 10 (Quantization of the algebra of observables). *The symbols $(\Sigma_{\rho,q})_{\rho \in \mathcal{Y}}$ form a $\mathbb{C}(q)$ -basis of $\mathcal{O}(q) = \mathcal{O} \otimes_{\mathbb{C}} \mathbb{C}(q)$ and yield a quantization of the basis $(\Sigma_{\rho})_{\rho \in \mathcal{Y}}$ of \mathcal{O} . Moreover, the transition matrices between the $\Sigma_{\rho,q}$ and the Σ_{ρ} are triangular, given by:*

$$(6) \quad (q-1)^{\ell(\rho)} \Sigma_{\rho,q}(\lambda) = \sum_{\nu \in \mathcal{Y}_k} \frac{q^{\nu} - 1}{z_{\nu}} \langle p_{\nu} | h_{\rho} \rangle \Sigma_{\nu}(\lambda);$$

$$(7) \quad (q^{\rho} - 1) \Sigma_{\rho}(\lambda) = \sum_{\nu \in \mathcal{Y}_k} (q-1)^{\ell(\nu)} \langle m_{\nu} | p_{\rho} \rangle \Sigma_{\nu,q}(\lambda).$$

4. FIRST ORDER ASYMPTOTICS

This section is devoted to the proof of Theorem 1. Let us fix a real $q \in]0, 1[$. The first step of the proof is the convergence of power sums of Frobenius coordinates.

4.1. Convergence of power sums. The q -Plancherel measure is a measure on Young diagrams, so the functions on Young diagrams and in particular the elements of \mathcal{O} are in this context random variables. In particular we will denote by \mathbb{E} their expectation. Thanks to the characterization of the q -Plancherel measure with the normalized trace (paragraph 2.2), one has immediately:

$$\mathbb{E}[\Sigma_{\rho,q}] = \begin{cases} n^{\downarrow k} & \text{if } \rho = 1^k; \\ 0 & \text{else.} \end{cases}$$

By using the triangular relation between the Σ_{ρ} and the $\Sigma_{\nu,q}$, we obtain:

$$(8) \quad \begin{aligned} \mathbb{E}[\Sigma_{\rho}] &= \frac{1}{q^{\rho} - 1} \sum_{\nu \in \mathcal{Y}_k} (q-1)^{\ell(\nu)} \langle m_{\nu} | p_{\rho} \rangle \mathbb{E}[\Sigma_{\nu,q}] = \frac{(q-1)^{|\rho|}}{q^{\rho} - 1} n^{\downarrow |\rho|} \langle m_{1^{|\rho|}} | p_{\rho} \rangle \\ &= \frac{(1-q)^{|\rho|}}{1-q^{\rho}} n^{\downarrow |\rho|} \end{aligned}$$

This gives in particular the asymptotic order of magnitude:

$$\mathbb{E}[\Sigma_{\rho}] = O(n^{|\rho|}) = O(n^{\deg(\Sigma_{\rho})})$$

In fact, this is true for any measure on Young diagrams, but not always precise enough (for example, to study the usual Plancherel measure, one has to use the fact that it is $O(n^{(|\rho| + \ell(\rho))/2})$). In this context, the exact computation above shows that we could not find a better bound. As $(\Sigma_{\rho})_{\rho \in \mathcal{Y}}$ is a linear basis of \mathcal{O} , the previous estimation remains true for any element of \mathcal{O} .

Lemma 11. *For any $x \in \mathcal{O}$, one has $\mathbb{E}[x] = O(n^{\deg(x)})$.*

This lemma allows us to forget terms of lower degree when we want to look at the asymptotic behavior of the expectation of some observable. In particular, one can obtain the following result for the power sums of the Frobenius coordinates:

Lemma 12 (Convergence of power sums). *Under the q -Plancherel measures, we have convergence in probability of the renormalized power sums $p_k(\lambda)$:*

$$\forall k \geq 1, \quad \frac{p_k(\lambda)}{|\lambda|^k} \xrightarrow{M_{n,q}} \frac{(1-q)^k}{1-q^k}.$$

Proof. An immediate consequence of equation (8) is that $\mathbb{E}[\Sigma_{\rho}]/n^{|\rho|} \rightarrow (1-q)^{|\rho|}/(1-q^{\rho})$ when n goes to infinity. But $\Sigma_{\rho} - p_{\rho}$ is an observable of degree less than $|\rho| - 1$, so the same holds for p_{ρ} :

$$\lim_{n \rightarrow \infty} \frac{\mathbb{E}[p_{\rho}]}{n^{|\rho|}} = \frac{(1-q)^{|\rho|}}{1-q^{\rho}}$$

Fix $\varepsilon > 0$ and $k \geq 1$. The Bienaymé-Chebyshev inequality ensures that

$$\begin{aligned} M_{n,q} \left[\left| \frac{p_k}{n^k} - \frac{(1-q)^k}{1-q^k} \right| \geq \varepsilon \right] &\leq \frac{1}{\varepsilon^2} \mathbb{E} \left[\left(\frac{p_k}{n^k} - \frac{(1-q)^k}{1-q^k} \right)^2 \right] \\ &\leq \frac{1}{\varepsilon^2} \left(\frac{\mathbb{E}[p_{k,k}]}{n^{2k}} - 2 \frac{\mathbb{E}[p_k]}{n^k} \frac{(1-q)^k}{1-q^k} + \frac{(1-q)^{2k}}{1-q^{2k}} \right), \end{aligned}$$

whence the result by using the estimations of $\mathbb{E}[p_\rho]$ for $\rho = (k)$ and $\rho = (k, k)$. \square

Corollary 13 (Convergence of the characters and q -characters). *Under the q -Plancherel measures, we have the following convergences in probability:*

$$\begin{aligned} \forall \rho \in \mathcal{Y}, \quad \frac{\Sigma_\rho}{n^{|\rho|}} &\longrightarrow_{M_{n,q}} \frac{(1-q)^{|\rho|}}{1-q^\rho} \quad \text{i.e. } \chi^\lambda(\rho) \longrightarrow_{M_{n,q}} \frac{(1-q)^{|\rho|}}{1-q^\rho}; \\ \forall \rho \in \mathcal{Y}, \quad \frac{\Sigma_{\rho,q}}{n^{|\rho|}} &\longrightarrow_{M_{n,q}} \delta_{\rho=1^{|\rho|}} \quad \text{i.e. } \chi^\lambda(\rho, q) \longrightarrow_{M_{n,q}} \delta_{\rho=1^{|\rho|}}. \end{aligned}$$

Proof. It is a direct consequence of Proposition 7, Lemmas 11 and 12. \square

4.2. Convergence of lengths of rows. Note that the limit values of the rescaled p_k 's are the power sums of the sequence $((1-q), (1-q)q, (1-q)q^2, \dots)$. Indeed,

$$\sum_{i=1}^{\infty} (1-q)^k q^{(i-1)k} = \frac{(1-q)^k}{1-q^k}.$$

In this paragraph, we will show that the convergence of the power sums implies the convergence of the sequence. This will finish the proof of Theorem 1.

The main idea is to consider, given a Young diagram λ of size n , the probability measure X_λ defined by

$$X_\lambda = \sum_{i=1}^d (a_i^*(\lambda)/n) \delta_{(a_i^*(\lambda)/n)} + (b_i^*(\lambda)/n) \delta_{(-b_i^*(\lambda)/n)}.$$

The k -th moment of X_λ is exactly $p_{k+1}(\lambda)/n^{k+1}$. So, thanks Lemma 12, under q -Plancherel measure, the moments of X_λ , which can be seen as random variables, converge in probability towards the moments of the measure

$$X_{\infty;q} = \sum_{i=1}^{\infty} (1-q)q^{i-1} \delta_{(1-q)q^{i-1}}.$$

Lemma 14. *As usual, we consider a sequence of random diagrams $\lambda_n \in \mathcal{Y}_n$ taken with q -Plancherel measure. At any point $x \neq (1-q)q^{i-1}$, one has convergence in probability of the repartition functions, that is to say:*

$$\sum_{\substack{y \leq x \\ ny \in A_\lambda + \bar{B}_\lambda}} |y| \longrightarrow_{M_{n,q}} \sum_{(1-q)q^{i-1} \leq x} (1-q)q^{i-1}.$$

Proof. In the following, we consider $\lambda \mapsto X_\lambda$ as a *measure-valued random variable* $X_{n,q}$; its law is by definition the image of $M_{n,q}$ by $\lambda \mapsto X_\lambda$. The set $\mathcal{M}([-1, 1])$ of signed Radon measures on $[-1, 1]$, where $X_{n,q}$ takes its values, is the dual of $\mathcal{C}([-1, 1])$ and is compact and metrizable for the $*$ -weak topology¹. Indeed, if $(f_n)_{n \in \mathbb{N}}$ is a sequence of continuous functions dense in $\mathcal{C}([-1, 1])$, then

$$d(m_1, m_2) = \sum_{n \in \mathbb{N}} \frac{1}{2^n} \max(1, |m_1(f_n) - m_2(f_n)|)$$

¹It is a particular case of the Prohorov theorem: if E is a separable and complete metric space (in other words, a polish space), then the same holds for the set of probability measures $\mathcal{M}(E)$, see [Bil69, Chapter 1]. As a consequence, convergence in probability makes sense for random probability measures on a closed subset of the real line.

is a distance compatible with the topology of $\mathcal{M}([-1, 1])$. We choose $\{f_n\}_{n \in \mathbb{N}} = \mathbb{Q}[X]$ (dense by Stone-Weierstrass theorem), thus the convergence of moments implies that $X_{n,q}$ converges in probability in $(\mathcal{M}([-1, 1]), d)$ towards $X_{\infty,q}$.

But, for Radon measures on the real line, the weak convergence $X_{n,q} \rightharpoonup X_{\infty,q}$ is equivalent to the convergence of repartition functions $F_{X_{n,q}}(x) \rightarrow F_{X_{\infty,q}}(x)$ at points $x \in [-1, 1]$ where $F_{X_{\infty,q}}$ is continuous — it is a part of the Portmanteau theorem ([Bil69, Chapter1]). \square

End of proof of Theorem 1. Now, let us take $x = 1 - q + \eta$ with $\eta > 0$ sufficiently small. We also fix $1 - q > \varepsilon > 0$. Note that $F_{X_{\infty,q}} = 1$ on a vicinity of x . Consequently, for n big enough and outside a set of arbitrary small probability, all rows of λ are smaller than nx , because

$$F_{X_\lambda}(x) = \sum_{\substack{y \leq x \\ ny \in A + \overline{B}}} |y| \geq F_{X_{\infty,q}}(x) - \varepsilon = 1 - \varepsilon > q,$$

and this could not be if a row were bigger than $n(1 - q + \eta)$. Indeed, we would then have

$$F_{X_\lambda}(1) \geq F_{X_{n,q}}(x) + 1 - q + \eta > 1 + \eta > 1.$$

Hence, for n big enough, $a_1^*(\lambda)/n$ is smaller than x outside a set of arbitrary small probability. Now, if $x' = 1 - q - \eta$, then $F_{X_{\infty,q}} = q$ on a vicinity of x' , and therefore, for n big enough and outside a set of arbitrary small probability, some rows of λ are bigger than nx' ; otherwise, we would have

$$F_{X_\lambda}(1) = F_{X_\lambda}(x') \leq F_{X_{\infty,q}}(x') + \varepsilon = q + \varepsilon < 1.$$

We conclude that for n big enough and outside a set of arbitrary small probability, the rescaled first column $a_1^*(\lambda)/n$ is between x' and x . Consequently, $a_1^*(\lambda)/n$ converges in probability towards $1 - q$, and the same argument holds for the following rows (with an induction on the index i of the row). Of course, $a_i^*(\lambda)/n - \lambda_i/n = O(1/n)$, so we have proved Theorem 1. \square

Remark 2. If we take $x = 0$ in Lemma 14, then we see that $\sum_{i=1}^d b_i^*(\lambda)/n$ goes to 0 in probability: so, the order of magnitude of the columns is a $o(n)$. Unfortunately, we are not able to give an equivalent for the quantities λ_i' ($i \geq 1$).

Remark 3. The proof will work for any measure for which we can compute expectation of character values as soon as (the following condition implies the convergence of variance of power sums towards 0 in Lemma 12):

$$\mathbb{E}(\Sigma_{k,k}) = \mathbb{E}(\Sigma_k)^2 + o(n^{2k}).$$

This is similar to the result obtained by Biane for balanced diagrams in [Bia01].

4.3. Link with the infinite Hecke algebra. The technicalities of the previous paragraph could have been avoided by using a general result of Kerov that ensures that, if $(\lambda_n)_{n \in \mathbb{N}}$ is a (random) sequence of diagrams of size n such that the normalized characters χ^{λ_n} converge (in probability), then the renormalized Frobenius coordinates $(a_i^*(\lambda_n)/n, b_i^*(\lambda_n)/n)$ have a limit (α, β) in the Thoma simplex

$$\Omega = \left\{ ((\alpha_i)_{i \geq 1}, (\beta_i)_{i \geq 1}) \mid \alpha_1 \geq \alpha_2 \geq \dots \geq 0, \beta_1 \geq \beta_2 \geq \dots \geq 0, \gamma = 1 - \sum_{i=1}^{\infty} (\alpha_i + \beta_i) \geq 0 \right\},$$

cf. [KV81], [Ker03] and [KOV04]. Moreover, this limit can be computed, using the limit of the normalized characters. Therefore using Kerov's result, one could deduce directly Theorem 1 from Corollary 13 and skip the previous paragraph. However, Kerov's arguments can not be used for fluctuations and we would need the measure-valued random variable $X_{n,q}$ in subsection 5.3.

We give here more details on Kerov's arguments and how they fit for our work. This can be skipped during a first reading of the paper.

It is well-known that this infinite-dimensional simplex is involved in the representation theory of \mathfrak{S}_∞ and its Hecke algebra $\mathcal{H}_{\infty,q}$; let us recall briefly why. Since \mathfrak{S}_∞ is a wild group (*i.e.* with factor representations of type II or III), there is no hope to obtain a complete classification of all the unitary representations of $\mathbb{C}\mathfrak{S}_\infty$. However, such a classification has been obtained for the *finite factor representations*, *i.e.*, the unitary representations $U : \mathbb{C}\mathfrak{S}_\infty \rightarrow \mathcal{L}(H)$ whose von Neumann algebras $\mathcal{M}(U(\mathbb{C}\mathfrak{S}_\infty))$ admit a finite trace, see [Tho64] and [Oko94]. Let us denote by $H(\mathcal{Y})$ the convex compact set of normalized harmonic complex functions on the Young graph \mathcal{Y} . Then, $H(\mathcal{Y})$ parameterizes the normalized characters of \mathfrak{S}_∞ , and its boundary $\partial H(\mathcal{Y})$ parameterizes the irreducible characters of $\mathbb{C}\mathfrak{S}_\infty$. Moreover, this boundary can also be described topologically as the Thoma simplex, and if $x \in \mathbb{C}\mathfrak{S}_n$ and $(\alpha, \beta) \in \Omega$, then

$$\chi^{\alpha,\beta}(x) = \sum_{\lambda \in \mathcal{Y}_n} s_\lambda(\alpha, \beta) \varsigma^\lambda(x),$$

where $s_\lambda(\alpha, \beta)$ denotes the super-symmetric Schur function s_λ taken on the difference of alphabets $\alpha - \bar{\beta}$. Finally, if $x \in \mathbb{C}\mathfrak{S}_m$ and if $(\lambda_n)_{n \geq m}$ is a sequence of diagrams of sizes n such that the renormalized Frobenius coordinates $(a_i^*(\lambda_n)/n, b_i^*(\lambda_n)/n)$ have a limit $(\alpha, \beta) \in \Omega$, then

$$\chi^{\lambda_n}(x) \rightarrow \chi^{\alpha,\beta}(x).$$

By harmonic analysis on the Young graph, S. Kerov showed the converse statement: the convergence of characters implies the existence of limit frequencies (α, β) . Moreover, the same results hold for the infinite Hecke algebra $\mathcal{H}_{\infty,q}$: it suffices to replace the characters by the q -characters in the previous argument. Now, Corollary 13 can be viewed as a concentration result of the q -characters around the regular trace τ_q of $\mathcal{H}_{\infty,q}$: indeed, $\chi^\lambda(\rho, q) \rightarrow_{M_{n,q}} \tau_q(\rho)$ for any partition ρ . Since

$$\chi^{\alpha,\beta}(T_{\sigma_\rho}, q) = \sum_{\lambda \in \mathcal{Y}_n} s_\lambda(\alpha, \beta) \varsigma^\lambda(\rho, q) = \tilde{q}_\rho(\alpha, \beta, q),$$

a simple computation shows that $\tau_q = \chi^\omega(q)$ with $\omega = (((1-q)q^{i-1})_{i \geq 1}, 0)$. In other words, the q -Plancherel measure of the infinite Hecke algebra is the Dirac at ω , and the limit frequencies of the rows and columns of a random Young diagram under the q -Plancherel measures could have been deduced directly from Corollary 13 and the result of Kerov.

Note that, to use Kerov's result, we need a convergence in probability of character values and not only the convergence of the expectations: in other words, only subsection 4.2 can be avoided. In addition, our method is interesting as the measure X_λ will be used in the analysis of fluctuations (paragraph 5.3).

Remark 4. In subsection 2.3, we have seen an algebraic interpretation of the regular trace τ_q on $\mathcal{H}_{n,q}$. It is the restriction of the usual trace of the space $\text{End}_{\mathbb{C}} \mathbb{C}[\text{GL}(n, \mathbb{F}_q)/\text{B}(n, \mathbb{F}_q)]$ to the subalgebra of $\text{GL}(n, \mathbb{F}_q)$ -morphisms, which is isomorphic to $\mathbb{C}[\text{B}(n, \mathbb{F}_q) \backslash \text{GL}(n, \mathbb{F}_q) / \text{B}(n, \mathbb{F}_q)]$. There is a similar interpretation for τ_q on $\mathcal{H}_{\infty,q}$, but one has to consider the group $\text{GLB}(\mathbb{F}_q)$, which is slightly bigger than $\text{GL}(\infty, q)$, see [KV98]. Then, τ_q is the restriction of the usual trace of $L^1(\text{GLB}(\mathbb{F}_q), m_{\text{Haar}})$ to the subalgebra of compactly supported functions that are constant on $\text{B}(\infty, \mathbb{F}_q)$ -double cosets, this subalgebra being isomorphic to $\mathcal{H}_{\infty,q}$.

5. SECOND ORDER ASYMPTOTICS

In this section, we investigate the second order asymptotics of the rows of diagrams under the q -Plancherel measure and we prove Theorem 2. As in the previous section, the first part of the proof consists in studying asymptotics of p_k . In particular, we shall prove:

Proposition 15 (Fluctuations of p_k). *Under the q -Plancherel measure, we have the following convergence result. If we denote the renormalized centered power sum by*

$$W_{n,q,l}(\lambda) = \sqrt{n} \left(\frac{p_l(\lambda) - \mathbb{E}[p_l]}{n^l} \right),$$

then, for any $k \geq 1$, the finite random vector $(W_{n,q,1}, W_{n,q,2}, \dots, W_{n,q,k})$ converges in law towards a gaussian vector of covariance matrix:

$$\text{cov}(W_{q,l}, W_{q,m}) = lm(1-q)^{l+m} \left(\frac{1}{1-q^{l+m-1,1}} - \frac{1}{1-q^{l,m}} \right).$$

Before we start, recall that the algebra of observables \mathcal{O} admits two different products: the *usual product* of (commuting) observables \cdot and the *disjoint product* \bullet , cf. section 3. We shall denote by \mathcal{O}^\bullet the algebra with the latter product, and by \mathbb{E}^{id} the identification $\mathcal{O} \rightarrow \mathcal{O}^\bullet$. The proof of Proposition 15 relies on the interaction of the two products and on the expectation of character values $\mathbb{E}[\Sigma_\rho] = n^{|\rho|} (1-q)^{|\rho|} / (1-q^\rho)$.

5.1. Bound for cumulants. This kind of results (computing the fluctuations of an observable from the character values) has already been stated by P. Śniady in the case where the characters are small and the corresponding diagrams balanced. Here, we have to use different observables and a different gradation, but the ideas of the proof are the same, and the definitions of the different cumulants used here come from [Śni06]. In particular we shall use joint cumulants of random variables $k(X_1, \dots, X_r)$, which can be defined by induction² on r :

$$\mathbb{E}[X_1 X_2 \cdots X_r] = \sum_{\substack{\pi \text{ partition} \\ \text{of } \{1,2,\dots,r\}}} k(X_{i \in \pi_1}) k(X_{i \in \pi_2}) \cdots k(X_{i \in \pi_\ell}).$$

A centered gaussian vector (Y_1, \dots, Y_k) is characterized by the fact that all $k(Y_{i_1}, \dots, Y_{i_r})$ are equal to 0 for $r \neq 2$. Moreover, the values for $r = 2$ give then the covariance matrix. Therefore, the proof of Proposition 15 consists in computing the limit of $k(W_{n,q,i_1}, \dots, W_{n,q,i_r})$. In fact, we will show a stronger result than the convergence towards 0 for $r \geq 3$:

Lemma 16 (Order of magnitude of cumulants). *For any $x_1, x_2, \dots, x_r \in \mathcal{O}$, one has:*

$$k(x_1, \dots, x_r) = O\left(n^{\deg(x_1) + \cdots + \deg(x_r) - r + 1}\right).$$

The end of this subsection is devoted to the proof of this lemma. Thanks to the multi-linearity of cumulants (for $r \geq 2$) and a good behavior with respect to products (see [LS59] and [Śni06, Theorem 4.4]), it is enough to prove this lemma with the x_i in any graded algebraic basis of \mathcal{O} . A good choice is the basis $(\Sigma_k)_{k \geq 1}$; indeed, we have already computed the expectation of these observables under the q -Plancherel measure. Unfortunately, we do not know their joint moments $\mathbb{E}[\Sigma_{i_1} \cdots \Sigma_{i_r}]$, which are different from what we have computed in the previous section, namely, $\mathbb{E}[\Sigma_{i_1, \dots, i_r}]$.

5.1.1. Cumulants k^\bullet . This difficulty disappears if we use the algebra \mathcal{O}^\bullet , because $\Sigma_{i_1} \bullet \cdots \bullet \Sigma_{i_r} = \Sigma_{i_1, \dots, i_r}$. This algebra gives rise to a new kind of cumulants, the so-called disjoint cumulants, which we shall denote by $k^\bullet(X_1, \dots, X_r)$. Their definition is the same as for $k(X_1, \dots, X_r)$, except that the product of observables is now the disjoint product:

$$(9) \quad \mathbb{E}[X_1 \bullet X_2 \bullet \cdots \bullet X_r] = \sum_{\substack{\pi \text{ partition} \\ \text{of } \{1,2,\dots,r\}}} k^\bullet(X_{i \in \pi_1}) k^\bullet(X_{i \in \pi_2}) \cdots k^\bullet(X_{i \in \pi_\ell}).$$

It is easy to prove the analog of Lemma 16 for these disjoint cumulants:

Lemma 17 (Order of magnitude of disjoint cumulants). *For any $x_1, x_2, \dots, x_r \in \mathcal{O}$, one has:*

$$k^\bullet(x_1, \dots, x_r) = O\left(n^{\deg(x_1) + \cdots + \deg(x_r) - r + 1}\right).$$

²It can also be defined via generating functions.

Proof. As for classical cumulants, it is enough to prove it for $x_j = \Sigma_{i_j}$. In this case, the left-hand side of (9) is simply

$$\mathbb{E}[\Sigma_{i_1, \dots, i_r}] = \frac{(q-1)^{i_1 + \dots + i_r}}{\prod (q^{i_j} - 1)} n^{\downarrow(i_1 + \dots + i_r)}.$$

Except for the factor $n^{\downarrow(i_1 + \dots + i_r)}$, everything is multiplicative with respect to the parts of λ . More formally, there exist numbers α_i such that:

$$\begin{aligned} \mathbb{E}[\Sigma_{i_1, \dots, i_r}] &= \left(\prod_j \alpha_{i_j} \right) n^{\downarrow(i_1 + \dots + i_r)}; \\ &= \left(\prod_j \alpha_{i_j} \right) \mathbb{E}[\Sigma_{\underbrace{1, \dots, 1}_{i_1 + \dots + i_r \text{ times}}}], \end{aligned}$$

An immediate induction implies that:

$$k^\bullet(\Sigma_{i_1}, \dots, \Sigma_{i_n}) = \left(\prod_j \alpha_{i_j} \right) k^\bullet(\underbrace{\Sigma_1, \dots, 1}_{i_1 \text{ times}}, \dots, \underbrace{\Sigma_1, \dots, 1}_{i_r \text{ times}}).$$

But $\chi^\lambda(\Sigma_{1^i}) = n^{\downarrow i}$ for any λ , so the corresponding cumulants do not depend on the measure considered on Young diagrams, and we can use the result of P. Śniady who proved ([Śni06, Lemma 4.8]) that:

$$k^\bullet(\underbrace{\Sigma_1, \dots, 1}_{i_1 \text{ times}}, \dots, \underbrace{\Sigma_1, \dots, 1}_{i_r \text{ times}}) = O(n^{i_1 + \dots + i_r - (r-1)}).$$

This ends the proof of this lemma. \square

5.1.2. *Cumulants k^{id} .* The last problem is to link classical and disjoint cumulants. Thanks to the commutativity of the diagram below

$$\begin{array}{ccc} \mathcal{O} & \xrightarrow{\mathbb{E}^{\text{id}}} & \mathcal{O}^\bullet \\ \mathbb{E} = M_{n,q} \searrow & & \swarrow \mathbb{E} = M_{n,q} \\ & \mathbb{C} & \end{array}$$

this can be done by using a result of Brillinger [Bri69]. One obtains the following formula, see [Śni06, Proposition 4.1]:

$$(10) \quad k(X_1, X_2, \dots, X_n) = \sum_{\pi \vdash n} k^\bullet(k^{\text{id}}(X_{i \in \pi_1}), k^{\text{id}}(X_{i \in \pi_2}), \dots, k^{\text{id}}(X_{i \in \pi_\ell})),$$

where k^{id} is the cumulant corresponding to the identity map \mathbb{E}^{id} of the diagram (note that k^{id} takes value in \mathcal{O}), that is to say that it is defined by

$$X_1 X_2 \cdots X_r = \sum_{\substack{\pi \text{ partition} \\ \text{of } \{1, 2, \dots, r\}}} k^{\text{id}}(X_{i \in \pi_1}) \bullet k^{\text{id}}(X_{i \in \pi_2}) \bullet \cdots \bullet k^{\text{id}}(X_{i \in \pi_\ell}).$$

We will prove the following bound on the degree of identity cumulants. For any i_1, \dots, i_r , one has:

$$(11) \quad \deg(k^{\text{id}}(\Sigma_{i_1}, \dots, \Sigma_{i_r})) \leq i_1 + \dots + i_r - (r-1).$$

Note that it is not the same as [Śni06, Theorem 4.3]; indeed, we use a different gradation on the algebra of observables.

Let us begin by looking at $k^{\text{id}}(\Sigma_{i_1}, \dots, \Sigma_{i_n})$ for small values of n . For $n = 1$, by definition $k^{\text{id}}(\Sigma_i) = \Sigma_i$. For $n = 2$, one has:

$$k^{\text{id}}(\Sigma_{i_1}, \Sigma_{i_2}) = \Sigma_{i_1} \cdot \Sigma_{i_2} - \Sigma_{i_1, i_2}.$$

But one has also

$$\begin{aligned}\Sigma_{i_1} \cdot \Sigma_{i_2} &= \sum_{A_1 \in \mathcal{A}(n, i_1), A_2 \in \mathcal{A}(n, i_2)} C(A_1) C(A_2); \\ \Sigma_{i_1, i_2} &= \sum_{\substack{A_1 \in \mathcal{A}(n, i_1), A_2 \in \mathcal{A}(n, i_2) \\ A_1 \cap A_2 = \emptyset}} C(A_1) C(A_2).\end{aligned}$$

so the difference k^{id} is equal to the same expression with the sum restricted to pairs of arrangements which have a non-empty intersection:

$$k^{\text{id}}(\Sigma_{i_1}, \Sigma_{i_2}) = \sum_{\substack{A_1 \in \mathcal{A}(n, i_1), A_2 \in \mathcal{A}(n, i_2) \\ A_1 \cap A_2 \neq \emptyset}} C(A_1) C(A_2).$$

It turns out that the identity cumulants satisfy a similar identity in the general case, and the intersections between the A_j play again a significant role. First, note that:

$$\Sigma_{i_1} \cdots \Sigma_{i_r} = \sum_{\forall j, A_j \in \mathcal{A}(n, i_j)} C(A_1) \cdots C(A_r)$$

Given a family A_1, \dots, A_r of arrangements, we consider the relation \sim_1 defined by $k \sim_1 l \Leftrightarrow A_k \cap A_l \neq \emptyset$. It can be completed in an equivalence relation; let us denote by $\pi(A_1, \dots, A_r)$ the corresponding partition of $\llbracket 1, r \rrbracket$. Obviously, this partition depends only on which indices are equal and not on the values they take, so the sum of $C(A_1) \cdots C(A_r)$ over arrangements corresponding to a given partition is of the form $X_{i_1, \dots, i_r}^{\mathcal{G}}$ (notation of paragraph 3.4) and we can use Lemma 8 on this kind of expression.

Lemma 18. *For any i_1, \dots, i_r , one has:*

$$k^{\text{id}}(\Sigma_{i_1}, \dots, \Sigma_{i_r}) = \sum_{\substack{\forall j, A_j \in \mathcal{A}(n, i_j) \\ \pi(A_1, \dots, A_r) = \{\llbracket 1, r \rrbracket\}}} C(A_1) \cdots C(A_r).$$

Proof. We will prove this statement by induction on r . As explained above, it is true for $r = 1, 2$. Let us suppose that it is true for all $s \leq r - 1$. Because of the definition of the disjoint product \bullet , for every *non-trivial* set partition π , one has:

$$k^{\text{id}}(\Sigma_{i \in \pi_1}) \bullet k^{\text{id}}(\Sigma_{i \in \pi_2}) \bullet \cdots \bullet k^{\text{id}}(\Sigma_{i \in \pi_\ell}) = \sum_{\substack{\forall j, A_j \in \mathcal{A}(n, i_j) \\ \pi(A_1, \dots, A_r) = \pi}} C(A_1) \cdots C(A_r).$$

Indeed, the induction hypothesis applies for each part π_i , so we only keep terms corresponding to sequences of arrangements for which two numbers in the same part of π are in the same part of $\pi(A_1, \dots, A_r)$. Besides, when we make the product \bullet , we take only disjoint set of indices (using Lemma 8), so two numbers in different parts of π cannot be in the same part of $\pi(A_1, \dots, A_r)$.

We use now the inductive definition of k^{id} :

$$\begin{aligned}k^{\text{id}}(\Sigma_{i_1}, \dots, \Sigma_{i_r}) &= \Sigma_{i_1} \cdots \Sigma_{i_r} - \sum_{\pi \neq \{\llbracket 1, r \rrbracket\}} k^{\text{id}}(\Sigma_{i \in \pi_1}) \bullet k^{\text{id}}(\Sigma_{i \in \pi_2}) \bullet \cdots \bullet k^{\text{id}}(\Sigma_{i \in \pi_\ell}) \\ &= \sum_{\forall j, A_j \in \mathcal{A}(n, i_j)} C(A_1) \cdots C(A_r) - \sum_{\pi \neq \{\llbracket 1, r \rrbracket\}} \left(\sum_{\substack{\forall j, A_j \in \mathcal{A}(n, i_j) \\ \pi(A_1, \dots, A_r) = \pi}} C(A_1) \cdots C(A_r) \right) \\ &= \sum_{\substack{\forall j, A_j \in \mathcal{A}(n, i_j) \\ \pi(A_1, \dots, A_r) = \{\llbracket 1, r \rrbracket\}}} C(A_1) \cdots C(A_r),\end{aligned}$$

which is exactly the equality we wanted at rank r . □

Now, for every sequence of arrangements A_1, \dots, A_r such that $\pi(A_1, \dots, A_r)$ is the trivial partition $\{\llbracket 1, r \rrbracket\}$, the cardinal of $|A_1 \cup \dots \cup A_r|$ is smaller than $i_1 + \dots + i_r - (r - 1)$, because one has at least $r - 1$ equalities between different elements of these arrangements. So, $k^{\text{id}}(\Sigma_{i_1}, \dots, \Sigma_{i_r})$ can be written as a linear combination of Σ_λ with $|\lambda| \leq i_1 + \dots + i_r - (r - 1)$, which ends the proof of equation (11).

Finally, equations (10) and (11), together with Lemma 17, end the proof of Lemma 16.

5.2. Computation of covariances. Now, let us compute explicitly the limit (co)variances of the rescaled deviations of the Σ_k . First, note that if l and m are two positive integers, then:

$$\begin{aligned} k^\bullet(\Sigma_l, \Sigma_m) &= \mathbb{E}[\Sigma_l \bullet \Sigma_m] - \mathbb{E}[\Sigma_l] \mathbb{E}[\Sigma_m] = \mathbb{E}[\Sigma_{l,m}] - \mathbb{E}[\Sigma_l] \mathbb{E}[\Sigma_m] \\ &= \frac{(1-q)^{l+m}}{1-q^{l,m}} (n^{\downarrow l+m} - n^{\downarrow l} n^{\downarrow m}) = -lm \frac{(1-q)^{l+m}}{1-q^{l,m}} n^{l+m-1} + O(n^{l+m-2}) \end{aligned}$$

The last identity follows from the development of the falling factorial:

$$n^{\downarrow k} = n^k - \frac{k(k-1)}{2} n^{k-1} + O(n^{k-2})$$

Now, we can compute the higher term of the standard cumulant $k(\Sigma_l, \Sigma_m)$ if we use the graded development of $\Sigma_l \Sigma_m - \Sigma_{l,m}$ in the algebra of observables:

$$\begin{aligned} k(\Sigma_l, \Sigma_m) &= k^{\text{id}}(\Sigma_l, \Sigma_m) + k^\bullet(\Sigma_l, \Sigma_m) = \mathbb{E}[\Sigma_l \Sigma_m - \Sigma_{l,m}] + k^\bullet(\Sigma_l, \Sigma_m) \\ &= \mathbb{E}[lm \Sigma_{l+m-1}] - lm \frac{(1-q)^{l+m}}{1-q^{l,m}} n^{l+m-1} + O(n^{l+m-2}) \\ &= lm (1-q)^{l+m} \left(\frac{1}{1-q^{l+m-1,1}} - \frac{1}{1-q^{l,m}} \right) n^{l+m-1} + O(n^{l+m-2}) \end{aligned}$$

We have therefore proved:

Proposition 19 (Fluctuations of Σ_k). *If we denote $Z_{n,q,k} = \sqrt{n}(\Sigma_k/n^k - (1-q)^k/(1-q^k))$, then $(Z_{n,q,k})_{2 \leq k \leq K}$ converges in law towards a gaussian vector $(Z_{q,k})_{2 \leq k \leq K}$, with the following covariance matrix:*

$$k(Z_{q,l}, Z_{q,m}) = lm (1-q)^{l+m} \left(\frac{1}{1-q^{l+m-1,1}} - \frac{1}{1-q^{l,m}} \right)$$

End of the proof of Proposition 15. It turns out that the sequence $(W_{n,q,k})_{k \geq 2}$ of the rescaled deviations of power sums has the same limit law $(Z_{q,k})_{k \geq 2}$. Indeed, we have already shown that the limit of the rescaled deviations of power sums is a gaussian vector, and it suffices then to show that $k(p_l, p_m)$ has the same higher term as $k(\Sigma_l, \Sigma_m)$. According to the proposition 7, each symbol Σ_k is a rational polynomial in the $p_{l \leq k}$ with higher term p_k . So, we can use the multi-linearity of joint cumulants to write:

$$k(\Sigma_l, \Sigma_m) = k(p_l, p_m) + (\text{cumulants of observables } a_i, b_j \text{ with } \deg a_i + \deg b_j < l + m).$$

But if a and b are two observables of degree A and B , then we have seen that $k(a, b)$ is a $O(n^{A+B-1})$. As a consequence, the remaining terms are all $O(n^{l+m-2})$. This ends the proof of Proposition 15. \square

Remark 5. Lemma 16 implies also that the rescaled q -characters converge towards a gaussian vector. But for these q -characters, we are unable to give a general formula for the covariance because one has no good description of the product $\Sigma_{\rho,q} \Sigma_{\lambda,q}$. However, we can compute it for some given partitions ρ and λ : for instance,

$$\frac{\mathbb{E}[(\Sigma_{2,q})^2]}{n^4} = \left(\frac{q(1-q)^2}{1+q+q^2} \right) n^{-1} + \text{lower degree terms.}$$

Note that this value does not vanish except for $q = 1$, which means that the q -character $\chi_q(21^{n-2})$ has fluctuations of order $n^{-1/2}$ (and not n^{-1} as in the case $q = 1$). This seems to be also the case for the other q -characters.

5.3. Fluctuations of rows. As before, we denote by X_λ the probability measure on $[-1, 1]$ associated to a Young diagram λ , and by $X_{\infty;q}$ the limit probability measure of the X_λ under the q -Plancherel measures. If $f \in \mathcal{C}^1([-1, 1])$ is a continuously differentiable function on $[-1, 1]$, we define the rescaled deviation of f under q -Plancherel measure. It is the random variable $D_{n,q}(f)$ obtained by composition of q -Plancherel measure by the function:

$$\lambda \mapsto \sqrt{n} (X_\lambda(f) - X_{\infty;q}(f)),$$

where $\mu(f)$ is a short notation for $\int_{-1}^1 f d\mu$.

In this context, the convergence in law of rescaled power sums can be reformulated as a convergence in law of the vector $(D_{n,q}(x^l))_{1 \leq l \leq k}$ towards a gaussian vector $(Z_{q;l})$ of covariance matrix:

$$\begin{aligned} k(Z_{q;l}, Z_{q;m}) &= X_{\infty;q}((l+1)(m+1)x^l x^m) - (l+1)(m+1) X_{\infty;q}(x^l) X_{\infty;q}(x^m); \\ &= X_{\infty;q}((x^{l+1})'(x^{m+1})') - X_{\infty;q}((x^{l+1})') X_{\infty;q}((x^{m+1})'). \end{aligned}$$

Recall that with respect to the \mathcal{C}^1 -topology, $\mathbb{R}[X]$ is dense in the space of continuously differentiable functions $\mathcal{C}^1([-1, 1])$. By using this density together with the bilinearity of $D_{n,q}$ and covariance, we conclude that for any functions $f_1, f_2, \dots, f_r \in \mathcal{C}^1([-1, 1])$, the vector of rescaled deviations $D_{n,q}(f_i)$ converges towards a gaussian vector $(Z_{q;f_i})_{i \in [1, r]}$ of covariance matrix:

$$k(Z_{q;f_i}, Z_{q;f_j}) = X_{\infty;q}((x f_i)'(x f_j)') - X_{\infty;q}((x f_i)') X_{\infty;q}((x f_j)').$$

Proof of Theorem 2. If $i \geq 1$, we denote by f_i a class \mathcal{C}^1 and non-negative function such that $f_i(x) = 1$ on a vicinity V_i of $q^{i-1}(1-q)$ and $f_i(x) = 0$ outside a vicinity $W_i \supset V_i$, cf. figure 5. We shall also suppose that the W_i are disjoint open sets; in particular, $X_{\infty;q}(f_i) = q^{i-1}(1-q)$. Since $f_i'(q^{i-1}(1-q)) = 0$, $(x f_i)'(q^{i-1}(1-q)) = f_i(q^{i-1}(1-q)) = 1$, and as a consequence,

$$X_{\infty;q}((x f_i(x))'^2) - X_{\infty;q}((x f_i(x))')^2 = q^{i-1}(1-q) - q^{2(i-1)}(1-q)^2.$$

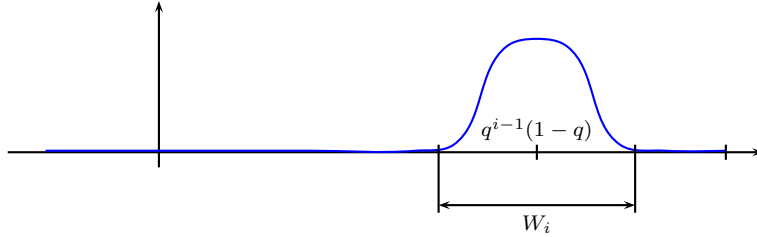

FIGURE 5. Graphical representation of the test function f_i .

Moreover, $f_i f_j = 0$ for all $i \neq j$, and the same holds for $f_i f_j'$, $f_i' f_j$ or $f_i' f_j'$. Therefore, the covariance matrix of the corresponding limit gaussian vector $(Z_{q;f_i})_{i \geq 1}$ is:

$$\begin{aligned} X_{\infty;q}((x f_i(x))'(x f_j(x))') - X_{\infty;q}((x f_i(x))') X_{\infty;q}((x f_j(x))') &= -X_{\infty;q}((x f_i(x))') X_{\infty;q}((x f_j(x))'); \\ &= -(1-q)^2 q^{i+j-2}. \end{aligned}$$

Finally, for n big enough and outside a set of arbitrary small probability, $a_i^*(\lambda)/n$ is in V_i , $a_{i-1}^*(\lambda)/n$ is in V_{i-1} and $a_{i+1}^*(\lambda)/n$ is in V_{i+1} . Thus, with a probability close to 1, the support of X_λ and the support of $f_i \neq 0$ intersect only at $a_i^*(\lambda)/n$, and $X_\lambda(f_i) = a_i^*(\lambda)/n$. As a consequence,

$$\sqrt{n} \left(\frac{a_i^*(\lambda)}{n} - q^{i-1}(1-q) \right) = \sqrt{n} (X_\lambda(f_i) - X_{\infty;q}(f_i)),$$

outside a set of arbitrary small probability, and the repartition functions of these random variables have the same asymptotic behavior. Theorem 2 follows then from the estimation $a_i^*(\lambda) = \lambda_i + O(1)$. \square

6. SCHUR-WEYL REPRESENTATIONS

In this section, we use the same tools to study other measures on partitions and to describe asymptotically the shape of the diagrams. The purpose of this section is to show that our method works as soon as the typical length of the first rows of the diagram is of order n^α with $\alpha > 1/2$ and not only with $\alpha = 1$.

6.1. Decomposition of tensor representations. We consider the following representation of the symmetric group: \mathfrak{S}_n acts on the space $(\mathbb{C}^N)^{\otimes n}$ by commuting the vectors of the pure tensors. Its character is very easy to compute: $\chi(\rho) = N^{\ell(\rho)}$, where $\ell(\rho)$ is the number of parts of the partition ρ (or, equivalently, the number of cycles of any permutation of type ρ).

This representation can be decomposed into irreducible representations of \mathfrak{S}_n : let us denote m_λ the multiplicity of the irreducible module S_λ . We associate to this decomposition the following measure on partitions

$$\mathbb{P}[\lambda] = \frac{m_\lambda \cdot \dim(S_\lambda)}{N^n}.$$

In other words, $\mathbb{P}[\lambda]$ is the dimension of the isotypic component of type λ divided by the total dimension of the module $(\mathbb{C}^N)^{\otimes n}$. Note that this is a very natural way to construct measure on Young diagrams of a given size: the same construction with the regular representation gives rise to the Plancherel measure.

An interesting thing with this kind of measure is that the expectation of rescaled character values is proportional to the character of the representation. In the case we are looking at (the action of \mathfrak{S}_n on $(\mathbb{C}^N)^{\otimes n}$),

$$\begin{aligned} \mathbb{E}[\Sigma_\rho] &= n^{\downarrow|\rho|} \cdot \frac{\chi(\rho 1^{n-|\rho|})}{N^n} \\ &= n^{\downarrow|\rho|} \cdot N^{\ell(\rho)-|\rho|}. \end{aligned}$$

Let us finish this paragraph by a little remark. By Schur-Weyl duality, one has the following isomorphism of $\mathfrak{S}_n \times \mathrm{GL}(N, \mathbb{C})$ -modules

$$(\mathbb{C}^N)^{\otimes n} \simeq \bigoplus_{\lambda \vdash n} V_\lambda \otimes U_\lambda,$$

where U_λ is an irreducible $\mathrm{GL}(N, \mathbb{C})$ -module. Moreover, the dimension of U_λ is the number of semi-standard tableaux of shape λ with entries lower or equal than N . So,

$$\mathbb{P}[\lambda] = \frac{\left| \left\{ \begin{array}{c} \text{standard tableaux} \\ \text{of shape } \lambda \end{array} \right\} \right| \cdot \left| \left\{ \begin{array}{c} \text{semistandard tableaux} \\ \text{of shape } \lambda \text{ (entries } \leq N) \end{array} \right\} \right|}{N^n}.$$

This implies, as mentioned in paragraph 1.2.3, that this measure is in fact the image of the uniform distribution on words of length n and letters from 1 to N by RSK algorithm.

6.2. Asymptotic shape of the diagrams. In the previous paragraph, we introduced some measure on Young diagrams of size n . Here we are interested in the asymptotic shape of typical diagrams when n tends to infinity. That means, as the measure we introduced also depends on an other parameter N , that we have to choose a value of N for each n . The case where the parameter N is equivalent of an expression of the kind $1/c \cdot n^\alpha$ with $\alpha \geq 1/2$ has already been solved by P. Biane [Bia01, paragraph 3.1]. So we will look at the case $\alpha < 1/2$.

Using the formula for expectation of normalized character values of the previous paragraph, one has:

$$(12) \quad \mathbb{E}[\Sigma_\rho] = n^{\downarrow|\rho|} \cdot N^{\ell(\rho)-|\rho|} \sim c^{|\rho|-\ell(\rho)} n^{|\rho|+\alpha\ell(\rho)-\alpha|\rho|}.$$

As in section 4, the first step is to show that the power sums have the same asymptotic behavior. Lemma 11 is true in this context, but not strong enough to obtain such a result. Unfortunately, with the gradation

we give in section 3, it is not possible to have a stronger upper bound. Thus one has to introduce another gradation on \mathcal{O} .

6.2.1. *Gradations on \mathcal{O} .* Let us define (this may not be an integer, but it does not matter):

$$\deg_\alpha(p_\rho) = |\rho| + \alpha\ell(\rho) - \alpha|\rho|.$$

As in the case $\alpha = 0$, the expression of Σ_k in terms of power sums (Proposition 7) gives us the degree and the top homogeneous component of Σ_ρ .

Lemma 20. *For any $\rho \in \mathcal{Y}$, one has:*

$$\Sigma_\rho = p_\rho + \text{terms of lower degree.}$$

Proof. It is enough to prove this for $\rho = (k)$. Note that the α -degree can be written as:

$$\deg_\alpha(p_\lambda) = (1 - 2\alpha)|\lambda| + \alpha(|\lambda| + \ell(\lambda)).$$

- (1) The first term is a positive multiple (recall that $\alpha < 1/2$) of the usual gradation, so if p_λ appears with a non-zero coefficient in Σ_k , one has $|\lambda| \leq k$, with equality if and only if $\lambda = (k)$.
- (2) The second term is a non-negative multiple of $2 \deg_{1/2}(\lambda) = |\lambda| + \ell(\lambda)$. An easy consequence of Proposition 7 is that all p_λ appearing in Σ_k fulfill the condition $|\lambda| + \ell(\lambda) \leq k + 1$. Note that we do not have the same necessary condition of equality as before: in fact, $\deg_{1/2}$ is a classical gradation of \mathcal{O} (see [IO02]), for which the top homogeneous component of Σ_ρ is *not* p_ρ .

Finally, Σ_ρ has degree $|\rho| + \alpha\ell(\rho) - \alpha|\rho|$, and its top homogeneous component for the new gradation is p_ρ . \square

6.2.2. *Convergence of rescaled power sums and concentration of characters.* Using equation (12), one has the following analog of Lemma 11 (the gradation has been chosen in this purpose):

Lemma 21. *For any $x \in \mathcal{O}$, one has: $\mathbb{E}[x] = O(n^{\deg_\alpha(x)})$.*

Now, we have all the tools to prove the convergence of rescaled powers sums:

Proposition 22. *Let $(N_n)_{n \geq 1}$ be a sequence of positive integers such that $N_n \sim c \cdot n^\alpha$ for some $\alpha < 1/2$. Under the measure associated with the action of symmetric groups on the spaces $(\mathbb{C}^{N_n})^{\otimes n}$, one has the following convergence in probability:*

$$\frac{p_k}{n^{k+\alpha-\alpha k}} \rightarrow c^{k-1}.$$

Proof. Equation (12), Lemma 20 and Lemma 21 imply that:

$$\mathbb{E}[p_\rho] \sim c^{\rho-\ell(\rho)} n^{|\rho|+\alpha\ell(\rho)-\alpha|\rho|}.$$

The result follows thanks to Bienaymé-Chebyshev inequality as in the case $\alpha = 0$. \square

Corollary 23 (Concentration of characters). *Under the same assumptions, in probability,*

$$\frac{\Sigma_\rho}{n^{|\rho|+\alpha\ell(\rho)-\alpha|\rho|}} \rightarrow c^{|\rho|-\ell(\rho)}.$$

6.2.3. *Consequences on the shape of diagrams.* To deduce some results on the shape of diagrams from the convergence of the quantities $p_k/(n^{k+\alpha-\alpha k})$, one has to interpret them as the moments of some measure-valued random variables. Therefore we define for a Young diagram λ the measure:

$$X_{\lambda,\alpha} = \sum_{i=1}^d (a_i^*(\lambda)/n^{1-\alpha}) \frac{\delta_{(a_i^*(\lambda)/n^{1-\alpha})}}{n^\alpha} + (b_i^*(\lambda)/n^{1-\alpha}) \frac{\delta_{(-b_i^*(\lambda)/n^{1-\alpha})}}{n^\alpha}.$$

With this definition, Proposition 22 can be read as the convergence in probability of the moments of this random-valued measure towards the sequence $(1, c, c^2, \dots)$, which is obviously the sequence of the moments of the measure δ_c .

As explained in Lemma 14, this implies the convergence of the repartition functions. It is an easy exercise left to the reader to show that this convergence can be reformulated as in Proposition 3.

Remark 6. The vector space $(\mathbb{C}^N)^{\otimes n}$ is also a representation of the unitary group U_N and, using Schur-Weyl duality, its isotypic components under the action of U_N are the same as under the action of S_n . As a consequence, results of article [CS09] can be used to study the asymptotic shape of the diagram. It turns out that, in the case $\alpha < 1/2$, this approach gives finer results than ours. Nevertheless, as they are two independent parameters, the space $(\mathbb{C}^N)^{\otimes n}$ remains a good example to show that our method works with any intermediate decay of character values between $O(1)$ and $O(\sqrt{n}^{-|\rho|+\ell(\rho)})$.

ACKNOWLEDGEMENTS

The authors would like to thank P. Biane for his valuable help. In addition, we want to mention that Theorem 1 was conjectured by the second author from examples (like Figure 1) obtained by computer exploration using the open-source mathematical software Sage [S⁺09] and its algebraic combinatorics features developed by the Sage-Combinat community [SCc08].

REFERENCES

- [BDJ99] J. Baik, P. Deift, and K. Johansson. On the distribution of the length of the longest increasing subsequence of random permutations. *J. Amer. Math. Soc.*, 12(4):1119–1178, 1999.
- [BDJ00] J. Baik, P. Deift, and K. Johansson. On the distribution of the length of the second row of a Young diagram under Plancherel measure. *Geometric And Functional Analysis*, 10(4):702–731, 2000.
- [Bia01] P. Biane. Approximate factorization and concentration for characters of symmetric groups. *Internat. Math. Res. Notices*, 4:179–192, 2001.
- [Bil69] P. Billingsley. *Convergence of Probability Measures*. Wiley, 1969.
- [BO000] A. Borodin, A. Okounkov, and G. Olshanski. Asymptotics of Plancherel measures for symmetric groups. *J. Amer. Math. Soc.*, 13(3):481–515, 2000.
- [Bri69] D. Brillinger. The calculation of cumulants via conditioning. *Ann. Inst. Statist. Math.*, 21:375–390, 1969.
- [CS09] B. Collins and P. Śniady. Asymptotic fluctuations of representations of the unitary groups. arXiv:0911.5546, 2009.
- [GP00] M. Geck and G. Pfeiffer. *Characters of Finite Coxeter Groups and Iwahori-Hecke Algebras*, volume 21 of *London Mathematical Society Monographs*. Oxford University Press, 2000.
- [IO02] V. Ivanov and G. Olshanski. Kerov’s central limit theorem for the Plancherel measure on Young diagrams. In *Symmetric Functions 2001: Surveys of Developments and Perspectives*, volume 74 of *NATO Science Series II. Mathematics, Physics and Chemistry*, pages 93–151, 2002.
- [Iwa64] N. Iwahori. On the structure of the Hecke ring of a Chevalley group over a finite field. *J. Faculty Science Tokyo University*, 10:215–236, 1964.
- [Ker96] S. V. Kerov. A differential model for the growth of Young diagrams. *Proceedings of the St. Petersburg Mathematical Society*, 4:165–192, 1996. English translation: American Mathematical Society Translations, Series 2, 188, 1998.
- [Ker03] S. V. Kerov. *Asymptotic representation theory of the symmetric group and its applications in analysis*, volume 219 of *Trans. Math. Monographs*. AMS, 2003.
- [KO94] S. V. Kerov and G. Olshanski. Polynomial functions on the set of Young diagrams. *Comptes Rendus Acad. Sci. Paris Série I*, 319:121–126, 1994.
- [KOV04] S. V. Kerov, G. Olshanski, and A. M. Vershik. Harmonic analysis on the infinite symmetric group. *Invent. Math.*, 158:551–642, 2004.
- [KV77] S. V. Kerov and A. M. Vershik. Asymptotics of the plancherel measure of the symmetric group and the limiting form of young tableaux. *Doklady AN SSSR*, 233(6):1024–1027, 1977. English translation: Soviet Mathematics Doklady 18:527–531, 1977.

- [KV81] S. V. Kerov and A. M. Vershik. Asymptotic theory of characters of the symmetric group. *Funkts. Anal. i Prilozhen*, 15:15–27, 1981. English translation: *Funct. Anal. Appl.* 15:246–255, 1982.
- [KV98] S. V. Kerov and A. M. Vershik. On an infinite-dimensional group over a finite field. *Funct. Anal. Appl.*, 32(3):147–152, 1998.
- [LS59] V. P. Leonov and A. N. Sirjaev. On a method of semi-invariants. *Theor. Prob. Appl.*, 4:319–329, 1959.
- [LS77] B. F. Logan and L. A. Shepp. A variational problem for random Young tableaux. *Adv. Math.*, 26:206–222, 1977.
- [Mac95] I. G. Macdonald. *Symmetric functions and Hall polynomials*. Oxford Mathematical Monographs. Oxford University Press, 2nd edition, 1995.
- [Mat99] A. Mathas. *Iwahori-Hecke algebras and Schur algebras of the symmetric group*, volume 15 of *University Lecture Series*. Amer. Math. Soc., 1999.
- [Oko94] A. Okounkov. Thoma’s theorem and representations of infinite bisymmetric group. *Funct. Anal.*, 28:101–107, 1994.
- [Oko00] A. Okounkov. Random matrices and random permutations. *Internat. Math. Res. Notices*, 20:1043–1095, 2000.
- [Ram91] A. Ram. A Frobenius formula for the characters of the Hecke algebras. *Invent. Math.*, 106:461–488, 1991.
- [RR97] A. Ram and J. B. Remmel. Applications of the Frobenius formulas for the characters of the symmetric group and the Hecke algebra of type A. *Algebraic Combinatorics*, 5:59–87, 1997.
- [RRW96] A. Ram, J. B. Remmel, and T. Whitehead. Combinatorics of the q-basis of symmetric functions. *Journal of Combinatorial Theory*, 76:231–271, 1996.
- [S⁺09] W. A. Stein et al. *Sage Mathematics Software (Version 4.2.1)*. The Sage Development Team, 2009. <http://www.sagemath.org>.
- [SCc08] The Sage-Combinat community. Sage-Combinat: enhancing sage as a toolbox for computer exploration in algebraic combinatorics, 2008. <http://combinat.sagemath.org>.
- [Śni06] P. Śniady. Gaussian fluctuations of characters of symmetric groups and of Young diagrams. *Probab. Theory Relat. Fields*, 136:263–297, 2006.
- [Str08] E. Strahov. A differential model for the deformation of the Plancherel growth process. *Adv. Math.*, 217(6):2625–2663, 2008.
- [Tho64] E. Thoma. Die unzerlegbaren, positive-definiten Klassenfunktionen der abzählbar unendlichen symmetrischen Gruppe. *Math. Zeitschrift*, 85:40–61, 1964.

LABORATOIRE BORDELAIS DE RECHERCHE EN INFORMATIQUE (LABRI), UNIVERSITÉ BORDEAUX 1, 351 COURS DE LA LIBÉRATION, 33 400 TALENCE, FRANCE

E-mail address: feray@labri.fr

THE GASPARD–MONGE INSTITUT OF ELECTRONIQUE AND COMPUTER SCIENCE, UNIVERSITY OF MARNE-LA-VALLÉE PARIS-EST, 77454 MARNE-LA-VALLÉE CEDEX 2, FRANCE

E-mail address: meliot@phare.normalesup.org