



HAL
open science

Spectral measurement of the thermal excitation of a superconducting qubit

Agustin Palacios-Laloy, F. Mallet, F. Nguyen, F. Ong, Patrice Bertet, Denis Vion, Daniel Esteve

► **To cite this version:**

Agustin Palacios-Laloy, F. Mallet, F. Nguyen, F. Ong, Patrice Bertet, et al.. Spectral measurement of the thermal excitation of a superconducting qubit. *Physica Scripta*, 2009, 2009 (T137), pp.014015. 10.1088/0031-8949/2009/T137/014015 . hal-00440275

HAL Id: hal-00440275

<https://hal.science/hal-00440275>

Submitted on 10 Dec 2009

HAL is a multi-disciplinary open access archive for the deposit and dissemination of scientific research documents, whether they are published or not. The documents may come from teaching and research institutions in France or abroad, or from public or private research centers.

L'archive ouverte pluridisciplinaire **HAL**, est destinée au dépôt et à la diffusion de documents scientifiques de niveau recherche, publiés ou non, émanant des établissements d'enseignement et de recherche français ou étrangers, des laboratoires publics ou privés.

Spectral measurement of the thermal excitation of a superconducting qubit

A. Palacios-Laloy, F. Mallet, F. Nguyen, F. Ong, P. Bertet,
D. Vion, D. Esteve

Abstract. We report the measurement of the fluctuations of a transmon qubit through the noise spectrum of the microwave signal that measures its state. The amplitude of the Lorentzian noise power spectrum allows to determine the average qubit excitation, in agreement with the estimated thermal radiation reaching the sample. Its width yields the qubit energy relaxation rate which decreases with temperature, contrary to the predictions for a two-level system solely coupled to thermal radiation. This indicates the existence of another non-radiative energy relaxation channel for the qubit.

Superconducting qubits [1] are promising candidates for implementing a solid-state quantum processor. Over the last years, substantial improvements have been made in the coherence times [2, 3], fidelity of single-qubit gates [4], readout procedures [5, 6] and entanglement of several qubits [7]. In a recent experiment a simple quantum algorithm was operated on a two-qubit elementary processor [8]. One of the requirements for the implementation of larger scale quantum algorithms [9] is that the qubit registers should be properly initialized at the beginning of each computation, with all qubits lying in their ground state. In most superconducting qubit experiments, the initialization is simply realized by waiting long enough before each experimental sequence for the system to reach thermal equilibrium. At cryogenic temperatures in the 10 – 30 mK range and for typical qubit resonance frequencies of a few GHz, there is indeed at thermal equilibrium a small (typically less than 1%) probability of finding the qubits in the excited state, which is usually considered negligible. However, given the recent improvement of the overall fidelity of single- and two-qubit gates, the effect of even small thermal fluctuations will require to be considered more quantitatively in the near future. Moreover it is well known in mesoscopic physics that the effective temperature of an electrical degree of freedom such as a superconducting qubit can be in some cases much larger than the temperature of the cryostat, because it can be strongly coupled to out-of-equilibrium electromagnetic radiation coming from the measuring leads, while only weakly to the phonon bath. It is thus important to be able to measure precisely the average excited state population of a single qubit.

Here we propose and demonstrate a method to determine this thermal excited state population in a circuit Quantum Electrodynamics (cQED) setup [10], where a Cooper-pair box qubit of the transmon type [11, 3] is coupled to a coplanar waveguide resonator (CPW). The two qubit states shift differently the resonator frequency, so that the phase of a microwave signal reflected by the resonator allows a non-destructive readout as demonstrated in numerous experiments [12]. In the present setup as in most cQED experiments, it is not possible to readout the qubit state in one single experimental sequence due to insufficient signal-to-noise ratio. Note however that such a single-shot readout was recently obtained in cQED by using a non-linear CPW resonator [5]. The usual method for reading out the qubit state, using ensemble-averaged measurements of the microwave signal, does not directly provide an absolute measurement of the qubit excitation. However, thermal fluctuations of the qubit state are responsible for a measurable phase noise in the microwave signal reflected by the resonator, with a characteristic Lorentzian power spectrum. In this work we report the observation of this thermal noise and we use it to determine the effective qubit temperature. We note that a related measurement was performed on an ensemble of nuclear spins measured by a SQUID amplifier[13].

The complete experimental setup is shown in Fig 1. The transmon has its two lowest energy eigenstates $|g\rangle$ and $|e\rangle$ separated by $\omega_{ge}/2\pi = 5.304$ GHz. It is capacitively coupled with strength $g/2\pi = 45 \pm 2$ MHz to a superconducting resonator with resonance frequency $\omega_c/2\pi = 5.796$ GHz and bandwidth $BW = 30.3$ MHz, which serves as qubit readout. With these parameters, the qubit is sufficiently detuned from the resonator for their interaction to be well described by the dispersive Hamiltonian $H = \hbar\chi\hat{n}\hat{\sigma}_z$, where χ is the dispersive coupling constant and \hat{n} is the intra-resonator photon number operator. The resonator frequency is thus shifted by $\pm\chi/2\pi = 1.75$ MHz when the qubit is in $|g\rangle$ or $|e\rangle$ respectively. A continuous microwave tone of frequency $\omega_c/2\pi$ sent to the resonator input from source V_m acquires a qubit state-dependent phase shift which allows a continuous and non-destructive monitoring

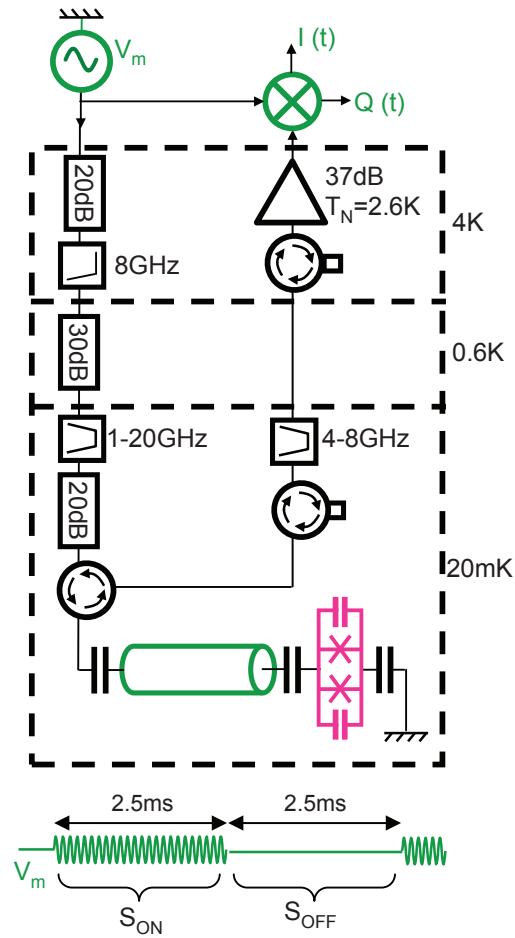

Figure 1. Microwave setup used for measurements. A microwave signal V_m is sent through the input line containing several attenuators and filters at each temperature stage to the input port of the resonator (shown in green). The reflected signal is separated from the input one by a circulator and goes through a filter and two isolators before reaching the cryogenic amplifier (gain 37 dB and noise temperature 2.6 K). The signal is then demodulated at room temperature with a homodyne demodulation scheme to get its in-phase and quadrature components $I(t)$ and $Q(t)$ respectively (for sake of simplicity details of the room temperature demodulation scheme, including several stages of amplification are not shown). Switching the signal ON and OFF with 1ms period allows to subtract the noise background coming from the amplifier.

of this state. This continuous measurement does not induce spurious qubit excitation as long as the the intra-resonator photon number ($\bar{n} \simeq 2.5$ in our measurements) is much below the critical photon number $n_{crit} = (\omega_{ge} - \omega_c)^2 / 4g^2 \simeq 30$ above which the dispersive approximation fails. After reflection on the resonator, the signal is routed through a circulator to a cryogenic amplifier and is then measured by homodyne detection at room-temperature, yielding the two field quadratures $I(t)$ and $Q(t)$. The thermal fluctuations of the qubit state induce some phase noise on the reflected microwave signal, and thus some noise on each quadrature $X(t)$ ($X = I, Q$).

We start by computing the power spectrum of the qubit thermal fluctuations. Assuming that the bath consists of a bosonic Markovian bath at temperature T , as expected for the impedance of the electromagnetic environment, the qubit dynamics at thermal equilibrium is described by a simple rate equation [14]

$$\dot{\rho}_{ee} = -\dot{\rho}_{gg} = -\Gamma\rho_{ee} + \Gamma n_{th}(1 - 2\rho_{ee}) \quad (1)$$

where Γ is the qubit energy relaxation rate, and $n_{th}(T) = (\exp(\hbar\omega_c/kT) - 1)^{-1}$ is the mean photon number at temperature T . This yields a steady-state population of the qubit excited state $\rho_{ee}^{th} = \frac{n_{th}}{1+2n_{th}}$, or $z_{th} = -\frac{1}{1+2n_{th}}$ after conversion into spin units $z(t) = 2\rho_{ee}(t) - 1$. The corresponding noise power spectrum $S_z(\omega)$ can be computed as the Fourier Transform of the two-time correlation function $C_z(\tau) = \langle z(\tau)z(0) \rangle$ which is

$$C_z(\tau) = 4 \exp(-\Gamma(1 + 2n_{th})\tau) [1 - \rho_{ee}^{th}] \rho_{ee}^{th}. \quad (2)$$

After Fourier transform, we obtain

$$S_z(\omega) = 4 \frac{\Gamma(1 + 2n_{th})}{\Gamma^2(1 + 2n_{th})^2 + \omega^2} [1 - \rho_{ee}^{th}] \rho_{ee}^{th}. \quad (3)$$

Note that these expressions are only approximate because the transmon is not a genuine two-level system but an anharmonic resonator with an infinite number of excited states. The previous expressions are thus only valid in the limit where the population of these higher excited states is negligible, which in our case is true up to temperatures around 100 mK.

We model the effect of the qubit state thermal fluctuations on the measuring signal quadratures $X(t)$ by assuming that the field inside the resonator follows instantaneously the qubit state. Here this assumption is justified by the large bandwidth of the resonator, obtained by choosing a large resonator input capacitor. The quadratures are then simply expressed as $X(t) = \bar{X} + (\Delta X/2)z(t) + \xi(t)$, where \bar{X} is the average reflected signal for a qubit fully unpolarized, ΔX is the change in X when the qubit changes state, and $\xi(t)$ is the total output noise of the amplifier. In the experiment we measure the sum of the noises on both quadratures

$$S_{V,ON}(\omega) = S_I(\omega) + S_Q(\omega) = S_\xi(\omega) + (\Delta V/2)^2 S_z(\omega), \quad (4)$$

where $S_\xi(\omega)$ is the output amplifier noise power spectrum and $(\Delta V/2)^2 = (\Delta I/2)^2 + (\Delta Q/2)^2$ is the detector sensitivity. This quantity has the advantage of being insensitive to drifts of the phase between the local oscillator used in the demodulation and the measurement signal. It is worth noting that the mere presence of a continuous measurement of the qubit state has no effect on the dynamics of thermal fluctuations because this dynamics is fully incoherent and entirely governed by Markovian rate equations [15]. The situation is very different when the qubit is continuously measured

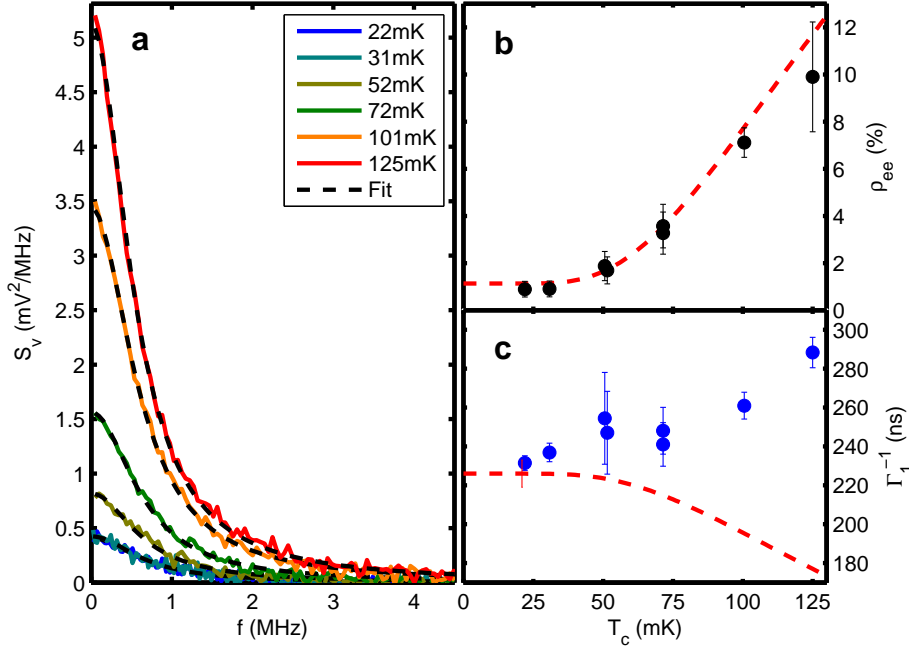

Figure 2. (a) Noise spectra acquired for several temperatures T_c (color solid lines) and lorentzian fits (dashed black lines). (b) Thermal population of the TLS as a function of temperature: comparison of the experimental data (black dots) with the theoretical prediction (red dashed curve). (c) Relaxation times as a function of temperature extracted from the widths of the lorentzian spectra (blue dots) compared to the predictions of the model discussed in the text (red dashed curve) taking $\Gamma^{-1} = T_{1,20mK} = 226 \pm 7$ ns, independently measured in a pulsed experiment at 20 mK.

while being coherently driven, in which case the dynamics changes from diffusive Rabi oscillations to quantum jumps when the measurement strength is increased [16].

We measure the detector output noise spectrum $S_V(\omega)$ for a series of temperatures T_c . Each spectrum is measured after waiting 15 minutes thermalization time once the cryostat reaches T_c . We also verify that the sample is well thermalized by acquiring two noise spectra for each T_c , one upon warming up and the second upon cooling down, which are found to be nearly identical. Each spectrum is acquired by sampling $I(t)$ and $Q(t)$ with 100MHz sampling frequency. Each 1024-point set of the sampled signals is Fourier transformed and the amplitude of this transform is squared to obtain the noise spectra $S_I(\omega)$ and $S_Q(\omega)$, which are then corrected for the variations of setup gains in frequency and between the I and Q channels. The resulting spectra are summed to form $S_{V,ON}(\omega)$. Each 2.5 ms the measurement microwave is turned OFF to measure the noise background of the amplifier $S_{V,OFF}(\omega) = S_\xi(\omega)$ and subtract it from the signal. The resulting noise spectrum $S_V(\omega) = S_{V,ON}(\omega) - S_{V,OFF}(\omega)$ is averaged typically 10^6 times.

As shown in Fig 2a, the measured noise spectra $S_V(\omega)$ have a Lorentzian shape, with an amplitude rapidly increasing with temperature. The amplitude A and width Γ_1 of each spectrum are fitted with a Lorentzian model $A\Gamma_1/(\Gamma_1^2 + \omega^2)$. According to

Eqs 3 and 4, the model predicts that $\Gamma_1 = \Gamma(1 + 2n_{th})$ and $A = \Delta V^2 [1 - \rho_{ee}^{th}] \rho_{ee}^{th}$. The detector sensitivity ΔV^2 is experimentally calibrated in the following way : using exactly the same setup, we ensemble-average $V^2(t) = I^2(t) + Q^2(t)$ under saturation of the qubit $g \rightarrow e$ transition with a second microwave source at frequency $\omega_{ge}/2\pi$. This yields $\Delta V/2 = 2.76 \pm 0.14$ mV. In this way we can directly extract from the fits the thermally excited state population ρ_{ee} and the relaxation rates Γ_1 as a function of the cryostat temperature T_c .

The fitted population (dots in Fig. 2b) agrees with the theoretical average population ρ_{ee}^{th} (red dashed curve), calculated assuming two sources of radiation : the thermal field corresponding to the temperature of the cryostat coldest stage T_c , with an average of $n_{th}(T_c)$ photons, and the thermal field radiated by the 30 dB attenuator thermalized at the still temperature $T_S = 600 \pm 100$ mK, and attenuated (22 ± 0.5 dB) at 20 mK, contributing with $n_{th}(T_S)/10^{2.2}$ photons. At the lowest T_c , we find a thermally excited state population of $1 \pm 0.5\%$, corresponding to an effective temperature of 55 mK.

At $T_c = 20$ mK, the relaxation rate Γ_1^{-1} deduced from the width of the Lorentzian noise spectrum (see Fig. 2c) is found to be in excellent agreement with the qubit relaxation time $T_{1,20mK} = 226 \pm 7$ ns, measured in a standard pulsed sequence. However, at higher T_c , we observe that the fitted width decreases, which implies that the qubit energy relaxation time increases with temperature. This counterintuitive result disagrees with our model which predicts a relaxation rate $\Gamma(n_{th}) = \Gamma(1 + 2n_{th})$ (see Eq. 1) increasing with temperature due to stimulated emission by the thermal field, yielding the red dashed curve in Fig. 2b (calculated with $\Gamma = T_{1,20mK}^{-1}$). This indicates that the qubit is not only coupled to its electromagnetic environment but also to another type of bath, causing some additional damping with a different temperature dependence. Additional support for this idea is that the measured relaxation time at 20 mK (226 ns) is significantly shorter than the expected damping time due to relaxation into the the external impedance at zero temperature (600 ns), which indicates the existence of a non-radiative energy decay channel. We finally note that a similar increase of the relaxation time with temperature up to 150 mK was directly observed in a superconducting phase qubit, and attributed to non-equilibrium quasiparticles in the superconducting metal electrodes [17]; a similar scenario might explain our results.

In conclusion, we have determined the thermal population of a superconducting qubit coupled to a resonator, even without single-shot detection capability, by studying the noise spectrum of its measuring signal. The population measured is in good agreement with the estimated thermal radiation reaching the sample. We observe however an increase in the relaxation time with temperature in contradiction with this model. This points to the existence of unknown non-radiative decay channels as observed in other qubit experiments [17].

Acknowledgments

We acknowledge financial support from European project EuroSQIP, Agence Nationale de la Recherche (grant ANR-08-BLAN-0074-01), and Region Ile-de-France for the nanofabrication facility at SPEC. We gratefully thank P. Senat, P. Orfila and J.-C. Tack for technical support, and acknowledge useful discussions within the Quantronics group.

Correspondance should be addressed to P.B.

- [1] Clarke J and Wilhelm F K 2008 *Nature* **453** 1031–1042
- [2] Vion D, Aassime A, Cottet A, Joyez P, Pothier H, Urbina C, Esteve D and Devoret M H 2002 *Science* **296** 886–889
- [3] Schreier J A, Houck A A, Koch J, Schuster D I, Johnson B R, Chow J M, Gambetta J M, Majer J, Frunzio L, Devoret M H, Girvin S M and Schoelkopf R J 2008 *Physical Review B* **77** 180502
- [4] Chow J M, Gambetta J M, Tornberg L, Koch J, Bishop L S, Houck A A, Johnson B R, Frunzio L, Girvin S M and Schoelkopf R J 2009 *Physical Review Letters* **102** 090502–4
- [5] Mallet F, Ong F R, Palacios-Laloy A, Nguyen F, Bertet P, Vion D and Esteve D Single-shot qubit readout in circuit quantum electrodynamics to be published
- [6] McDermott R, Simmonds R W, Steffen M, Cooper K B, Cicak K, Osborn K D, Oh S, Pappas D P and Martinis J M 2005 *Science* **307** 1299–1302
- [7] Steffen M, Ansmann M, Bialczak R C, Katz N, Lucero E, McDermott R, Neeley M, Weig E M, Cleland A N and Martinis J M 2006 *Science* **313** 1423–1425
- [8] DiCarlo L, Chow J M, Gambetta J M, Bishop L S, Johnson B R, Schuster D I, Majer J, Blais A, Frunzio L, Girvin S M and Schoelkopf R J 2009 *Nature* **460** 240–244
- [9] DPdiVincenzo 2000 *Fortschr. Phys.* **48** 771
- [10] Blais A, Huang R, Wallraff A, Girvin S M and Schoelkopf R J 2004 *Physical Review A* **69** 62320
- [11] Koch J, Yu T M, Gambetta J, Houck A A, Schuster D I, Majer J, Blais A, Devoret M H, Girvin S M and Schoelkopf R J 2007 *Physical Review A* **76** 42319
- [12] Wallraff A, Schuster D I, Blais A, Frunzio L, Huang R S, Majer J, Kumar S, Girvin S M and Schoelkopf R J 2004 *Nature* **431** 162–167
- [13] Sleator T, Hahn E L, Hilbert C and Clarke J 1985 *Phys. Rev. Lett.* **55** 1742–1745
- [14] Cohen-Tannoudji C, Dupont-Roc J and Grynberg G 1998 *Atom-Photon Interactions: Basic Processes and Applications* (Wiley-Interscience) ISBN 0471293369
- [15] Bernu J, Deléglise S, Sayrin C, Kuhr S, Dotsenko I, Brune M, Raimond J M and Haroche S 2008 *Phys. Rev. Lett.* **101** 180402
- [16] Palacios-Laloy A, Mallet F, Nguyen F, Bertet P, Vion D and Esteve D Experimental violation of the leggett-garg inequality with weak measurement submitted for publication
- [17] Martinis J M, Ansmann M and Aumentado J 2009 *arxiv:0904.2171*