



**HAL**  
open science

## Bit rate maximization for LP-OFDM with noisy channel estimation

Fahad Syed Muhammad, Jean-Yves Baudais, Jean-François H elard

► **To cite this version:**

Fahad Syed Muhammad, Jean-Yves Baudais, Jean-Fran ois H elard. Bit rate maximization for LP-OFDM with noisy channel estimation. 3rd International Conference on Signal Processing and Communication Systems, Sep 2009, Omaha, Nebrask, United States. pp.1–6, 10.1109/ICSPCS.2009.5306408 . hal-00429812

**HAL Id: hal-00429812**

**<https://hal.science/hal-00429812>**

Submitted on 18 Sep 2014

**HAL** is a multi-disciplinary open access archive for the deposit and dissemination of scientific research documents, whether they are published or not. The documents may come from teaching and research institutions in France or abroad, or from public or private research centers.

L'archive ouverte pluridisciplinaire **HAL**, est destin e au d p t et   la diffusion de documents scientifiques de niveau recherche, publi s ou non,  manant des  tablissements d'enseignement et de recherche fran ais ou  trangers, des laboratoires publics ou priv s.

# Bit rate maximization for LP-OFDM with noisy channel estimation

Fahad Syed Muhammad, Jean-Yves Baudais, and Jean-François Hélar

Institute of Electronics and Telecommunications of Rennes (IETR), 35043 Rennes Cedex, France

Email: {fahad.syed-muhammad, jean-yves.baudais, jean-francois.helard}@insa-rennes.fr

**Abstract**—The resource allocation problem to maximize the bit rate of a linear precoded orthogonal frequency division multiplexing (LP-OFDM) system is considered taking into account the effects of imperfect channel state information. A discrete bit loading algorithm is proposed, which sustains the target bit error rate even under high mean square error (MSE) of estimation. The proposed scheme enhances the robustness of the system against noisy channel estimation without significantly compromising on the system throughput. It is shown that the proposed LP-OFDM allocation is more robust to estimation noise than OFDM allocations and provides sustainable mean bit error rate performance even at high MSEs. The results are shown for a power line communication system using a well-known multipath channel model.

**Index Terms**—Adaptive modulation, imperfect channel state information, linear precoded orthogonal frequency division multiplexing (LP-OFDM), multiaccess communications, power line communications (PLC), resource management.

## I. INTRODUCTION

Adaptive modulation provides the ability to assign different number of bits to different subcarriers in modern multicarrier communication systems [1]. Since different subcarriers of a multicarrier system have different channel gains, thus they experience different values of signal-to-noise ratio (SNR). Therefore these subcarriers are capable of transmitting different number of bits while respecting the same error rate, for a given power spectral density (PSD) mask. The purpose of resource allocation is to optimize either the throughput or the robustness of the system. Under PSD constraint and for a given error rate, the resource allocation generally gives either the maximum bit rate for a given system margin or the maximum system margin for a target bit rate. The former is a rate maximization (RM) problem [2] and the latter one is a margin maximization (MM) optimization problem [3], which is also known in the literature as the problem of power minimization under fixed bit and error rate.

A precoding component can be combined with the classical orthogonal frequency-division multiplexing (OFDM) technique to form a Linear precoded OFDM (LP-OFDM) system. The idea is to group together a set of subcarriers. Each resulting set accumulates the energies of all of its subcarriers to achieve an equivalent SNR such that the total number of bits supported is greater than the sum of the bits supported by each subcarrier individually. The aim is to make the multicarrier system more flexible, with reduced limitations and improved overall system performance, without increasing the system

complexity significantly. Although initially used for multi-user access schemes, the idea of combining linear precoding technique with multicarrier modulation can be extended to all single-user OFDM systems.

In resource allocation, it is generally supposed that the channel has been perfectly estimated and according to the channel responses on different subcarriers, the bit and power are allocated. For example different constellations of quadrature amplitude modulation (QAM) can be used to assign different number of bits to subcarriers. In practice, perfect channel state information (CSI) is rarely achieved. The problem of imperfect CSI has already been discussed for OFDM systems in the literature [4], [5]. Studies on adaptive modulation based on imperfect CSI for multiple-input and multiple-output OFDM systems have also been performed [6]-[8]. In this paper, we consider the bit rate maximization problem for the LP-OFDM system, taking into account the imperfect CSI. The bit loading algorithm is proposed that takes into account the estimation noise when allocating bit and power to different subcarriers. The modified symbol error rate (SER) expressions are devised for different QAM modulation orders. These expressions are used in resource allocation algorithm to underload the system at higher MSEs for the sake of better mean bit error rate (BER) performance. An algorithm which does not take into account the estimation errors, can overload the system which subsequently degrades the mean BER performance.

The rest of the paper is organized as follows. In Section II, the structure of the LP-OFDM system is described. In Section III, the modified SER expressions are devised to be used in the proposed allocation. Section IV explains the iterative allocation for the OFDM system without taking into account the estimation noise. In Section V, bit and power allocation for LP-OFDM systems is considered under imperfect CSI scenario. A bit and power loading algorithm is also proposed here for LP-OFDM systems. In Section VI, simulation scenarios are discussed and results are presented for both systems using a multipath PLC channel model. Finally, Section VII concludes the paper.

## II. SYSTEM DESCRIPTION

The combination of classical OFDM with a linear precoding component results in a general LP-OFDM system. This LP-OFDM system is also known as spread-spectrum multicarrier multiple-access (SS-MC-MA) in mobile radio communications [9]. The classical system is modified by simply adding a

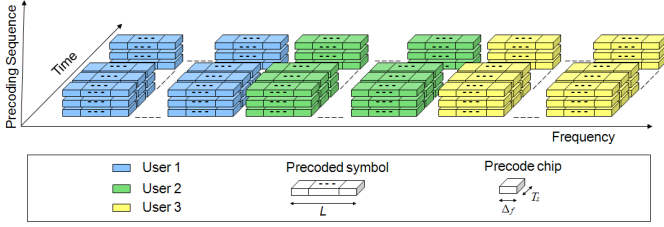

Fig. 1. LP-OFDM system description.

precoding block in the transmission chain, which applies the precoding in the frequency dimension. Thus the system complexity is not significantly increased. Furthermore, the linear precoded component can be exploited to reduce the peak-to-average power ratio (PAPR) of the OFDM system [10]. The linear precoding component improves the signal robustness against frequency selectivity and narrowband interference, since the signal bandwidth could become much larger than the coherence and interference bandwidths. It also accumulates the energies of many subcarriers by grouping them together which is useful in increasing the throughput especially under PSD constraint.

Fig. 1 shows the studied LP-OFDM system. The entire bandwidth is divided into  $N$  parallel subcarriers which are split up into  $K$  blocks  $S_k$  of  $L$  subcarriers, where  $k$  signifies the block number. The precoding function is then applied block-wise by mean of precoding sequences of length  $L$ , also known as precoding factor. Note that the subcarriers in a given block are not necessarily adjacent. Each user  $u$  of the network is being assigned a block  $B_u$  of subsets  $S_k$ . We emphasize that  $\forall u$ ,  $B_u$  are mutually exclusive subsets. Consequently, multiple access between the  $U$  users is managed following a frequency division multiple access (FDMA) approach, instead of a code division multiple access (CDMA) approach that is generally used in precoded systems, also called spreaded systems. In a general approach, the generated symbol vector at the output of the OFDM modulator for a single block LP-OFDM system can be written as

$$s = F^H M X. \quad (1)$$

Vector  $s$  is  $K$ -dimensional, with  $K$  the number of used subcarriers.  $X = [x_1, \dots, x_L]^T$  is the output of the serial-to-parallel conversion of the  $L$  QAM modulated symbols to be transmitted.  $M$  represents the precoding matrix of size  $K \times L$  applied to  $X$ , which precodes  $L$  symbols over the  $K$  subcarriers. This precoding matrix is composed of orthogonal Hadamard matrices. Finally,  $F^H$  represents the Hermitian of the unitary Fourier matrix of size  $K \times K$  that realizes the multicarrier modulation. It is worthy to mention here that we are going to consider the single user case only. The number of precoding sequences used to spread information symbols on one subset  $S_k$  is denoted by  $C^k$ , with  $0 \leq C^k \leq L$ , since we assume orthogonal sequences. A certain amount of energy  $E_c^k$  is assigned to each precoding sequence  $c^k$  associated to a given modulation symbol of  $b_c^k$  bits.

### III. MODIFIED SER EXPRESSIONS

As discussed earlier, the perfect channel estimation is not possible. Here, we will devise the new SER expressions taking into account the imperfect CSI. We use the error model described in [5] and a modified version of this model is shown in Fig. 2 with additional resource allocation component.

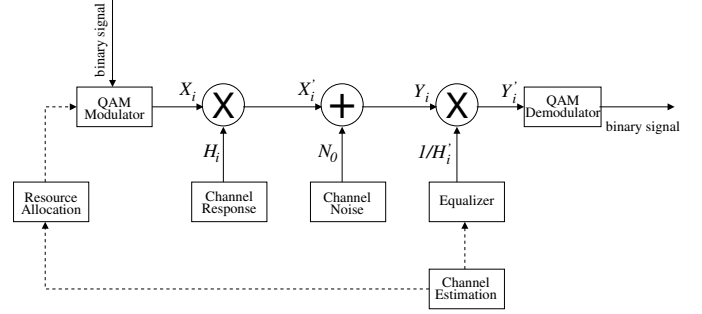

Fig. 2. MCM subcarrier estimation error model.

Here  $X_i$  is the modulated symbol at subcarrier  $i$ ,  $X'_i$  is modulated symbol after interacting with the channel gain  $H_i$ ,  $N_0$  is the additive white Gaussian noise,  $Y_i$  is the noisy modulated symbol, and  $Y'_i$  is the received symbol after being equalized by the estimated channel gain  $H'_i$ . We suppose that no error occurs when the estimated channel is fed back to the transmitter that means that we have the same estimated channel at the transmitter and the receiver. This estimated channel can be different from the actual channel in case of noisy estimation. Without channel noise, the decoding error can be avoided if the following inequality is satisfied:

$$\max \left| \frac{H_i - H'_i}{H'_i} \right| \cdot |X_i| < \frac{d}{2}, \quad (2)$$

where  $d$  is the minimum distance between constellation points. The maximum value of this expression occurs at  $X_{i,max}$ . For odd QAM constellations

$$X_{i,max} = \left[ \left( \sqrt{\frac{9M}{8}} - 1 \right) \cdot \frac{d}{2}, \left( \sqrt{\frac{M}{2}} - 1 \right) \cdot \frac{d}{2} \right], \quad (3)$$

where  $M$  is the modulation order. For even QAM constellations [5]

$$X_{i,max} = \left[ \left( \sqrt{M} - 1 \right) \cdot \frac{d}{2}, \left( \sqrt{M} - 1 \right) \cdot \frac{d}{2} \right]. \quad (4)$$

In [5] only the even QAM constellations were treated, we consider all possible QAM constellations (including the particular case of 8-QAM). The probability of error,  $P^m$ , for each constellation point with an odd QAM constellation, in presence of channel noise, can be given as

$$P^m = N^m Q \left[ \sqrt{\frac{3\text{SNR}}{M-1}} \left( 1 - \frac{4\sqrt{2}\alpha |X_i|}{d\sqrt{13M-20\sqrt{2M}+16}} \right) \right], \quad (5)$$

and for an even QAM constellation,  $P^m$  can be given as

$$P^m = N^m Q \left[ \sqrt{\frac{3\text{SNR}}{M-1}} \left( 1 - \frac{\sqrt{2}\alpha |X_i|}{d(\sqrt{M}-1)} \right) \right], \quad (6)$$

where  $N^m$  is the number of nearest neighbors to the constellation point  $X_{i,m}$  on  $i^{\text{th}}$  subcarrier and  $\alpha$  is a measure of the accuracy in channel identification. For an odd QAM constellation,  $\alpha$  can be given as

$$\alpha = \sqrt{\frac{\text{MSE} (13M - 20\sqrt{2M} + 16)}{8}}, \quad (7)$$

and for an even QAM constellation,  $\alpha$  can be given as

$$\alpha = \sqrt{2\text{MSE}} (\sqrt{M} - 1). \quad (8)$$

The overall probability of error on a given subcarrier can be given as

$$P = \sum_m \text{Prob}(X_i = X_{i,m}) \cdot P^m. \quad (9)$$

The modified SER,  $P$ , expressions obtained from this analysis are given below. For  $M = 4$

$$P = 2Q \left[ (1 - \alpha) \cdot \sqrt{\text{SNR}} \right]. \quad (10)$$

For  $M = 8$  with  $\beta = \sqrt{\frac{3\text{SNR}}{7}}$

$$P = Q[(1 - \alpha) \cdot \beta] + \frac{3}{2}Q \left[ \left( 1 - \frac{\alpha}{\sqrt{5}} \right) \cdot \beta \right]. \quad (11)$$

For  $M = 16$  with  $\beta = \sqrt{\frac{\text{SNR}}{5}}$

$$P = Q[(1 - \alpha) \beta] + \frac{3}{2}Q \left[ \left( 1 - \frac{\sqrt{5}\alpha}{3} \right) \beta \right] + Q \left[ \left( 1 - \frac{\alpha}{3} \right) \beta \right]. \quad (12)$$

For  $M = 32$  with  $\beta = \sqrt{\frac{3\text{SNR}}{31}}$

$$P = \frac{1}{2}Q[(1 - \alpha) \beta] + Q \left[ \left( 1 - \frac{\sqrt{5}\alpha}{\sqrt{17}} \right) \beta \right] + \frac{1}{2}Q \left[ \left( 1 - \frac{\alpha}{\sqrt{17}} \right) \beta \right] + \frac{3}{4}Q \left[ \left( 1 - \frac{\sqrt{13}\alpha}{\sqrt{17}} \right) \beta \right] + \frac{1}{4}Q \left[ \left( 1 - \frac{3\alpha}{\sqrt{17}} \right) \beta \right]. \quad (13)$$

For  $M = 64$  with  $\beta = \sqrt{\frac{\text{SNR}}{21}}$

$$P = \frac{1}{32}Q[(1 - \alpha) \beta] + \frac{1}{4}Q \left[ \left( 1 - \frac{\alpha}{7} \right) \beta \right] + \frac{1}{4}Q \left[ \left( 1 - \frac{3\alpha}{7} \right) \beta \right] + \frac{1}{2}Q \left[ \left( 1 - \frac{\sqrt{5}\alpha}{7} \right) \beta \right] + \frac{1}{2}Q \left[ \left( 1 - \frac{\sqrt{13}\alpha}{7} \right) \beta \right] + \frac{1}{2}Q \left[ \left( 1 - \frac{\sqrt{17}\alpha}{7} \right) \beta \right] + \frac{5}{8}Q \left[ \left( 1 - \frac{5\alpha}{7} \right) \beta \right] + \frac{3}{8}Q \left[ \left( 1 - \frac{\sqrt{29}\alpha}{7} \right) \beta \right] + \frac{3}{8}Q \left[ \left( 1 - \frac{\sqrt{37}\alpha}{7} \right) \beta \right]. \quad (14)$$

For  $M = 128$  with  $\beta = \sqrt{\frac{3\text{SNR}}{127}}$

$$P = \frac{1}{16}Q[(1 - \alpha) \beta] + \frac{1}{4}Q \left[ \left( 1 - \frac{\alpha}{\sqrt{17}} \right) \beta \right] + \frac{1}{4}Q \left[ \left( 1 - \frac{\alpha}{\sqrt{5}} \right) \beta \right] + \frac{1}{8}Q \left[ \left( 1 - \frac{\alpha}{\sqrt{85}} \right) \beta \right] + \frac{1}{8}Q \left[ \left( 1 - \frac{3\alpha}{\sqrt{85}} \right) \beta \right] + \frac{1}{4}Q \left[ \left( 1 - \frac{\sqrt{13}\alpha}{\sqrt{85}} \right) \beta \right] + \frac{3}{8}Q \left[ \left( 1 - \frac{\sqrt{5}\alpha}{\sqrt{17}} \right) \beta \right] + \frac{1}{4}Q \left[ \left( 1 - \frac{\sqrt{29}\alpha}{\sqrt{85}} \right) \beta \right] + \frac{1}{4}Q \left[ \left( 1 - \frac{\sqrt{37}\alpha}{\sqrt{85}} \right) \beta \right] + \frac{1}{8}Q \left[ \left( 1 - \frac{7\alpha}{\sqrt{85}} \right) \beta \right] + \frac{1}{4}Q \left[ \left( 1 - \frac{\sqrt{41}\alpha}{\sqrt{85}} \right) \beta \right] + \frac{1}{4}Q \left[ \left( 1 - \frac{3\alpha}{\sqrt{17}} \right) \beta \right] + \frac{1}{4}Q \left[ \left( 1 - \frac{\sqrt{53}\alpha}{\sqrt{85}} \right) \beta \right] + \frac{9}{32}Q \left[ \left( 1 - \frac{\sqrt{13}\alpha}{\sqrt{17}} \right) \beta \right] + \frac{3}{16}Q \left[ \left( 1 - \frac{\sqrt{61}\alpha}{\sqrt{85}} \right) \beta \right] + \frac{3}{16}Q \left[ \left( 1 - \frac{\sqrt{73}\alpha}{\sqrt{85}} \right) \beta \right]. \quad (15)$$

The SER expressions for higher modulation orders can also be derived using this analysis. It can be observed from (7) and (8) that  $\alpha$  is directly proportional to MSE. Therefore in devised SER expressions for higher MSE, higher values of SNR are required to attain the same target error rate. For an allocation which does not take into account the imperfect CSI, the SNR required to attain a given error rate does not change and therefore the mean BER performance degrades for higher MSEs. These modified SER expressions are used in the proposed loading algorithm, which takes into account the imperfect channel estimation.

#### IV. OFDM ALLOCATION WITHOUT IMPERFECT CSI CONSIDERATION

For a known channel response, the number of bits  $b_i$  supported by subcarrier  $i$  can be given as [11]

$$b_i = \log_2 \left( 1 + \frac{E_s |H_i|^2}{N_0 \Gamma} \right), \quad (16)$$

where  $\frac{E_s}{N_0}$  is the SNR,  $H_i$  is the channel gain at subcarrier  $i$ , and  $\Gamma$  is the SNR gap. The SNR gap,  $\Gamma$ , for any uncoded QAM with a target symbol error rate,  $P$ , and for a null system margin, is given as [11]

$$\Gamma = \frac{1}{3} \left[ Q^{-1} \left( \frac{P}{4} \right) \right]^2, \quad (17)$$

where  $Q^{-1}$  is the inverse of the well-known Q-function. It is clear from (17) that  $\Gamma$  depends upon the error rate of the system, and for a given error rate it has the same value for different modulation orders of QAM. In an allocation where effects of imperfect CSI are not considered the bits are allocated to different subcarriers in an iterative fashion by using (16), as  $\Gamma$  is known in advance. But in practice, where imperfect CSI is rarely achieved, the value of  $\Gamma$  which was calculated in advance remains no more valid. Therefore, the bits are wrongly allocated to the subcarriers, which results in an increase of BER at the receiver.

## V. PROPOSED LP-OFDM ALLOCATION

In practical systems, the perfect CSI is rarely achieved. The classical allocations do not consider the noisy estimation to change the allowed number of bits on a given subcarrier. In the proposed allocation the system is underloaded (less number of bits are allocated to subcarriers) in order to maintain the mean BER of the system. A bit and power loading algorithm is proposed that increases the system robustness against the noisy estimation without significantly compromising on the system throughput. It is supposed that the estimation noise is included at the receiver and no noise is added when this information is sent back to the transmitter through a feedback channel. Therefore we have the same estimated channel at both sides of the communication system. The well known power line channel is used for simulations and the feedback delay of the CSI is neglected because of the quasi static nature of the power line channel.

The channel estimation statistics depends on the estimation approach and the system parameters, therefore for the sake of simplicity, we characterize the estimation noise as additive Gaussian noise. The estimated channel gain is  $H_i' = H_i + e_i$ , where estimation noise is a complex Gaussian random variable with zero mean and a variance,  $\sigma_e^2$ , equal to the MSE of the channel estimator. It is also considered that  $H_i'$  is the only known information about the current CSI of the  $i^{\text{th}}$  subcarrier.

The rate maximization problem for the LP-OFDM system has been discussed in the existing literature (for example [2], and [13]) without taking into account the effects of imperfect CSI. Here, we propose a bit and power allocation algorithm for the LP-OFDM system that maximizes the bit rate of the system for a given error rate and a defined PSD limit but also takes into account the noisy channel estimation. We consider the LP-OFDM system with  $N$  subcarriers, precoding factor  $L$  and number of blocks  $K$ . The highest modulation order is limited to  $2^7$  and the minimum number of bits supported is 2. The target bit error rate per block is expected to be  $10^{-3}$ . Here, we propose a resource allocation algorithm where all

the precoding sequences in a given block are allocated the same number of bits and therefore are assigned equal transmit power, therefore  $b_c^k = R_k/L$  and  $E_c^k = E_k/L$  where  $b_c^k$  is the number of bits supported by the precoding sequence  $c^k$  of block  $k$ ,  $R_k$  is the number of bits in a block  $k$ ,  $E_c^k$  is the transmit power allocated to the precoding sequence  $c^k$  of block  $k$  and  $E_k$  is the total transmit power available at block  $k$ . The signal to noise ratio for a precoding sequence  $c^k$  of a block  $k$  can be given as

$$\text{SNR}_c^k = \frac{E_k}{N_0} \frac{L}{\sum_{i \in S_k} \frac{1}{|H_i|^2}}. \quad (18)$$

The proposed allocation treats one block at a time and processes all the block in a given LP-OFDM system iteratively. In each iteration the algorithm treats only one precoding sequence of the given block since the bits are uniformly distributed in a given block as discussed earlier. Due to this uniform distribution, all the precoding sequences in a block are assigned equal transmit power and therefore experience the same transmission behavior. At the end of each iteration, the resulted number of bits are generalized for each precoding sequence of the given block. The algorithm starts by allocating maximum number of bits allowed (i.e. 7) to the precoding sequence of the given block. The SNR of the precoding sequence is calculated using (18) and then the SER is calculated from (15). If this value of SER is less than  $10^{-3}$ , all the precoding sequence of the given block are allocated 7 bits and the algorithm enters into the next iteration (i.e. the next block). Otherwise the number of bits allocated is reduced by 1 and the corresponding expression is used to calculate the SER. This process continues until we achieve either an SER of less than  $10^{-3}$  or the number of bits allocated equals to 0. The proposed algorithm for the LP-OFDM system can be summarized as follows:

## RESOURCE-ALLOCATION()

```

1  for  $k \leftarrow 1$  to  $K$ 
2      do Calculate SNR form (18)
3          Calculate SER from (15)
4          while  $\text{SER} > 10^{-3}$ 
5              do  $b \leftarrow b - 1$ 
6                  switch  $b$ 
7                      case  $b < 2$  :
8                          break
9                      case  $b = 6$  :
10                         Calculate SER from (14)
11                     case  $b = 5$  :
12                         Calculate SER from (13)
13                     case  $b = 4$  :
14                         Calculate SER from (12)
15                     case  $b = 3$  :
16                         Calculate SER from (11)
17                     case  $b = 2$  :
18                         Calculate SER from (10)
19                 end switch

```

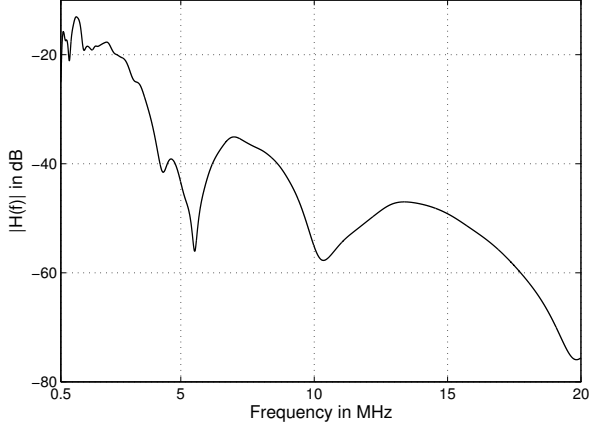

Fig. 3. 15-paths reference channel model for PLC [14]

TABLE I  
PARAMETERS OF THE 15-PATH MODEL.

attenuation parameters					
$k = 1$	$a_0 = 0$	$a_1 = 2.5 \cdot 10^{-9}$			
path-parameters					
$p$	$g_p$	$d_p$ (m)	$p$	$g_p$	$d_p$ (m)
1	0.029	90	9	0.071	411
2	0.043	102	10	-0.035	490
3	0.103	113	11	0.065	567
4	-0.058	143	12	-0.055	740
5	-0.045	148	13	0.042	960
6	-0.040	200	14	-0.059	1130
7	0.038	260	15	0.049	1250
8	-0.038	322			

```

20   end while
21   Allocate  $b$  to all the precoding sequences of  $k$ 
22    $E_c^k \leftarrow E_k/L$ 
23   end for

```

This algorithm uses different SER expressions for different constellation sizes and allocates bits and powers to the precoding sequences of the LP-OFDM system while taking into account the effects of noisy channel estimation. It unloads the system for higher MSEs to sustain a mean BER of the system and fairly increases the system robustness against imperfect CSI without significantly compromising on the system throughput.

## VI. SIMULATIONS AND RESULTS

In this section, we will present simulation results for the proposed allocation scheme. As a reference, we will also give the performance of the iterative OFDM allocation, which does not take into account the noisy channel estimation. We use the

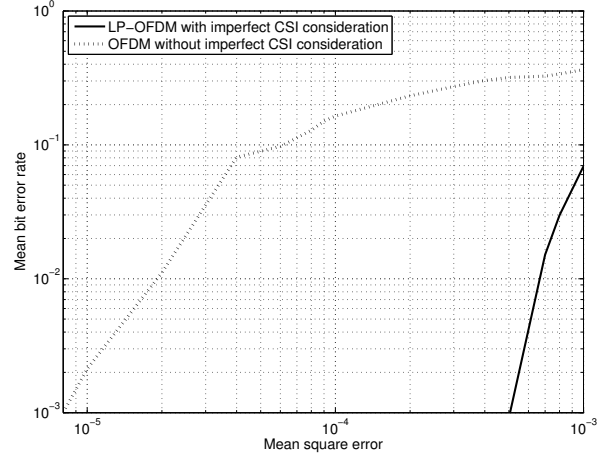

Fig. 4. Mean BER comparison for different values of mean square error.

multipath model for the power line channel, proposed in [14] and presented in Fig. 3. The considered reference model is 110 m link 15-paths model whose frequency response is given by

$$H(f) = \sum_{p=1}^{15} g_p \cdot e^{-(a_0 + a_1 f^k) d_p} \cdot e^{-j2\pi f \tau_p}, \quad (19)$$

where  $\tau_p$  is the delay of path  $p$ . The parameters of the 15-path model are listed in Table I. The generated OFDM/LP-OFDM signal is composed of  $N = 1024$  subcarriers transmitted in the band [500-20,000] kHz. The subcarrier spacing is 19.043 kHz. It is assumed that the synchronization has been successfully performed. A background noise level of  $-93$  dBm/Hz is assumed and the signal is transmitted with respect to a flat PSD of  $-40$  dBm/Hz. The precoding factor  $L$  for LP-OFDM is 32 while the highest modulation order is limited to  $2^7$  and the minimum number of bits supported is 2. The target bit error rate per block is expected to be  $10^{-3}$ . A complete communication system chain is simulated and the mean BER is calculated at the receiving side by dividing the total number of erroneous bits by the total bits received.

Fig. 4 shows the mean BER performance of both allocations for different values of MSE. It can be observed that the proposed allocation is robust against the estimation noise and provide sustainable BER performance as compared to iterative OFDM allocation, which does not take into account the effects of imperfect CSI. The proposed allocation is providing better mean BER performance even at much higher values of MSE. For instance, iterative OFDM allocation without imperfect CSI consideration, for MSEs higher than  $8 \cdot 10^{-6}$  results in mean BERs higher than  $10^{-3}$ , while the proposed allocation gives a mean BER less than  $10^{-3}$  until the MSE reaches at a value of  $5 \cdot 10^{-4}$ . For an  $MSE = 6 \cdot 10^{-5}$  the classical OFDM allocation results in a mean BER of  $10^{-1}$  while the proposed LP-OFDM allocation provides a mean BER of  $10^{-2}$  even at an MSE of  $6.6 \cdot 10^{-4}$ .

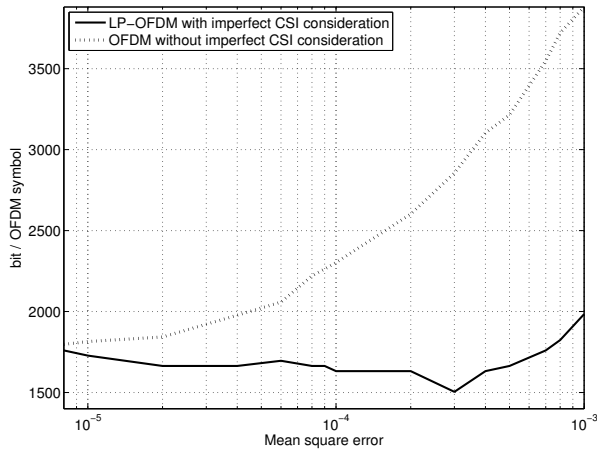

Fig. 5. Bit rate comparison for different values of mean square error.

Fig. 5 compares the throughput performance of both allocations for different values of MSE. The proposed allocation performs almost equal to the classical iterative OFDM allocation for  $MSE = 0$  but underloads the system once the MSE increases, as expected. The classical iterative OFDM is achieving higher bit rate for an higher MSEs, but as discussed earlier the mean BER performance of this allocation is collapsing for these MSEs. Thus these higher throughputs are of no use. Instead it is more useful to underload the system at this stage to maintain the mean BER performance and it is exactly what our proposed allocation is doing. For very strong estimation noise (i.e.  $MSE > 3 \cdot 10^{-4}$ ) the proposed allocation is also increasing the bit rate because at this level the estimation noise is so huge that it is dominating over the channel response. The proposed LP-OFDM allocation that takes into account the estimation noise is still performing better than the iterative OFDM allocation. The proposed algorithm is also less complex than the iterative OFDM allocation as the number of iterations has been reduced by grouping together different subcarriers.

## VII. CONCLUSION

The bit rate maximization problem for the LP-OFDM system is considered taking into account the effects of imperfect CSI. Modified SER expressions are devised for various QAM modulation orders, which incorporate the noisy channel estimation. A bit and power loading algorithm was proposed to maximize the bit rate of the system taking into account the imperfect CSI. It was observed that the proposed allocation provides significant robustness against noisy channel estimation. The proposed algorithm is also less complex than the classical OFDM allocation. We conclude that the proposed allocation provides sustainable mean BER performance with reasonable bit rate at higher estimation noise variance.

## ACKNOWLEDGMENT

The work in this paper is supported by the European Commission's Seventh Framework Programme FP7/2007-2013 under grant agreement n° 213311 also referred to as OMEGA.

## REFERENCES

- [1] I. Kalet, "The Multitone Channel," *IEEE Trans. Commun.*, vol. 37, no. 2, pp. 119-124, Feb 1989.
- [2] F. Syed-Muhammad, J.-Y. Baudais, J.-F. Héland, and M. Crussière, "A coded bit-loading linear precoded discrete multitone solution for power line communication," in *Proc IEEE Workshop on Signal Processing Advances in Wireless Commun.*, Recife, Brazil, 2008, pp. 555-559.
- [3] B.S. Krongold, K. Ramchandran, and D.L. Jones, "An efficient algorithm for optimal margin maximization in multicarrier communication systems," in *Proc IEEE GLOBECOM*, Rio de Janeiro, Brazil, 1999, pp. 899-903.
- [4] D. Dardari, "Ordered subcarrier selection algorithm for OFDM-based high-speed WLANs," *IEEE Trans. Wireless Commun.*, vol. 3, pp. 1452-1458, Sep. 2004.
- [5] A. Leke, J. M. Cioffi, "Multicarrier systems with imperfect channel knowledge," in *Proc PIMRC.*, 1998, pp. 549-553.
- [6] P. Xia, S. Zhou, and G. B. Giannakis, "Adaptive MIMO OFDM based on partial channel state information," *IEEE Trans. Signal Process.*, vol. 52, pp. 202-213, Jan. 2004.
- [7] G. Barriac, and U. Madhow, "Space-time communication for OFDM with implicit channel feedback," *IEEE Trans. Inform. Theory*, vol. 50, pp. 3111-3129, Dec 2004.
- [8] D.P. Palomar, "A unified framework for communications through MIMO channels", Universitat politecnica de Catalunya, PhD dissertation, May 2003.
- [9] K. Fazel, and S. Kaiser, *Multi-Carrier and Spread Spectrum Systems*, John Wiley & Sons, 2003.
- [10] S. Nobilet, J.-F. Héland, and D. Mottier, "Spreading sequences for uplink and downlink MC-CDMA systems: PAPR and MAI minimization," *European Trans. on Telecomm.*, vol. 13, no. 5, pp. 465-474, 2002.
- [11] J. Cioffi, A multicarrier primer ANSI T1E1.4/91-157, 1991, Committee contribution, Tech. Rep.
- [12] S. Ye, R. S. Blum, and L. J. Cimini, "Adaptive OFDM systems with imperfect channel state information," *IEEE Trans. Wireless Commun.*, vol. 5, no. 11, pp. 3255-3265, Nov. 2006.
- [13] M. Crussière, J.-Y. Baudais, and J.-F. Héland, "Adaptive spread-spectrum multicarrier multiple-access over wirelines," *IEEE Journal on Selected Areas in Communications*, vol. 24, no. 7, pp. 1377-1388, 2006.
- [14] M. Zimmermann and K. Dostert, "A multipath model for the powerline channel," *IEEE Trans. Commun.*, vol. 50, no. 4, pp. 553, Apr. 2002.
- [15] T.N. Zogakis, J.T. Aslanis, and J.M. Cioffi, "A Coded and shaped discrete multitone system," *IEEE Trans. Commun.*, vol. 43, no. 12, pp. 2941-2949, Dec. 1995.
- [16] M. Crussière, J.-Y. Baudais, and J.-F. Héland, "Loading Algorithms for Adaptive SS-MC-MA Systems over Wireline Channels: Comparison with DMT," *European Transactions on Telecommunications, Special Issue on the 5th Multi-Carrier Spread-Spectrum* vol. 17, no. 6, pp. 659-669, 2006.
- [17] J. Boutros, and E. Viterbo, "Signal space diversity: a power- and bandwidth-efficient diversity technique for the Rayleigh fading channel," *IEEE Trans. Inform. Theory*, vol. 44, pp. 1453-1467, Jul 1998.
- [18] Z. Wang, and G. B. Giannakis, "Linearly precoded or coded OFDM against wireless channel fades?," in *Proc IEEE Workshop on Signal Processing Advances in Wireless Commun.*, Taoyuan, Taiwan, 2001, pp. 267-270.