



HAL
open science

Three-dimensional metrology with the virtual fitting gauges

Eric Pairel

► **To cite this version:**

Eric Pairel. Three-dimensional metrology with the virtual fitting gauges. 11th CIRP International Conference on Computer Aided Tolerancing, Mar 2009, Annecy, France. pp.USB key. hal-00425076

HAL Id: hal-00425076

<https://hal.science/hal-00425076>

Submitted on 19 Oct 2009

HAL is a multi-disciplinary open access archive for the deposit and dissemination of scientific research documents, whether they are published or not. The documents may come from teaching and research institutions in France or abroad, or from public or private research centers.

L'archive ouverte pluridisciplinaire **HAL**, est destinée au dépôt et à la diffusion de documents scientifiques de niveau recherche, publiés ou non, émanant des établissements d'enseignement et de recherche français ou étrangers, des laboratoires publics ou privés.

Three-dimensional metrology with the virtual fitting gauges

Eric PAIREL

Associate Professor

Polytech'Savoie, University of Savoie

BP80439, 74844 Annecy-Le-Vieux Cedex, FRANCE

eric.pairel@univ-savoie.fr

Abstract

The metrology implemented in several classical software equipping the coordinate measuring machines, does not correspond to the standardized tolerancing by zones, virtual conditions and perfect datum features fitted outside the matter. On the basis of these concepts and by generalizing them, a conceptual model of "fitting virtual gauges" is presented. On a part presenting two positional tolerances, the plans of inspection according to the traditional metrology and according to the metrology by fitting gauges, are compared from the point of view of their simplicity and their potential results. A fitting gauges based software is under development. It will make it possible "to save" a certain number of parts declared not conform by traditional three-dimensional metrology.

Key words:

Three-dimensional metrology, virtual fitting gauges

1. INTRODUCTION AND POSITION OF THE PROBLEM

The standardized geometric tolerancing is a tolerancing by zones and virtual conditions whose locations are related to perfect features, known as datum, fitted to the surfaces of the part [1], [2], [3], [4]. For example, the perpendicularity tolerance of a drilling related to a plane, means that the drilling axis must be contained, in spite of its perpendicularity defect, in a cylindrical zone whose axis is perpendicular to a perfect plane fitted on the imperfect surface of the part. By imagining a cylindrical zone rigidly linked to a perpendicular perfect plane, the whole constitutes a kind of virtual gauge which, compared to the part, can be relocated in the directions allowed by the plane fitted on the part, in order to find a location making it possible to inscribe the drilling axis in the cylindrical zone.

Unfortunately the classical software which equip the coordinate measuring machines (CMM), do not make it possible to check the geometric tolerances according to such an approach by virtual gauge. The metrology allowed by those software is based on the measuring of distances between perfect geometric features, which either are fitted at the sampled points on the surfaces of the part, or built by the user. This method imposes an interpretation of the geometric tolerances and lead, in many cases, to a degraded inspection, unfavourable for the acceptance of the part. We will illustrate this metrology through an example of inspection of positional tolerances in section 4.2.

On the basis of the concepts of zone, of virtual conditions and perfect datum features used by standardized tolerancing, we have developed, during several years [5], a conceptual model of virtual gauges. We have called it the model of the fitting gauges because its virtual gauges seek to be fitted on the digitized surfaces, outside of the matter.

After a presentation of this model to the section 2, we will show its use in section 4, for the inspection of standardized geometric tolerances which will enable us to compare this new three-dimensional metrology, that we call metrology by

fitting gauges, with the traditional metrology allowed by the classical software.

2. THE FITTING GAUGES MODEL

2.1 Base of the elementary gauges

The model of the fitting gauges is founded on the association of a "gauge" to the different kind of clouds of sampled points.

Elementary surfaces which can be digitized on the parts are all of one of the seven classes of surfaces [6].

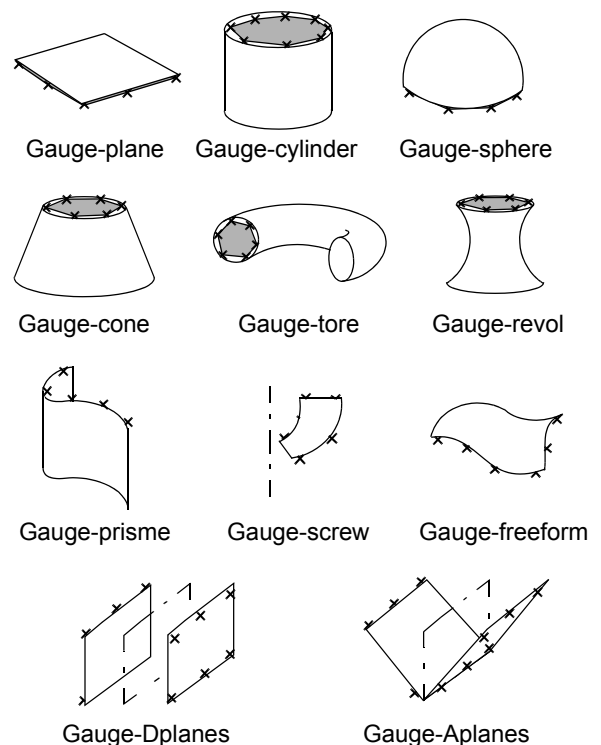

Figure 1: The Gauge-surfaces.

At each elementary surface is associated an elementary gauge. We name this first family of virtual gauges, the Surface-gauges (see Figure 1).

The gauges cone, torus and of revolution are of the same class. Moreover we add two very useful gauge-surfaces in three-dimensional metrology. They are characterized by an intrinsic size. We call them respectively Gauges-Dplanes and Gauges-Aplanes (see Figure 1).

From these gauge-surfaces we give the possibility of extracting from them, new kinds of clouds of points, which we call the Extracted-clouds:

- A point can be extracted in the center of a gauge-sphere.
- A virtual segment represented by two points can be extracted from a gauge of revolution (cylinder, cone or unspecified revolution) .
- Finally a planar polygon represented by a set of points can be extracted from the median plane of the Gauge-Dplanes and of the Gauges-Aplanes .

The Figure 2 recapitulates the Extracted-clouds that can be extracted from the Gauge-surfaces.

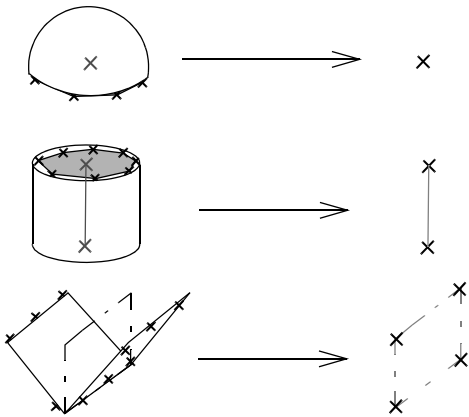

Figure 2: The Extracted-clouds.

With each kind of Extracted-cloud, we associate an elementary gauge. We call this second family of elementary gauges the Gauge-zones (see Figure 3).

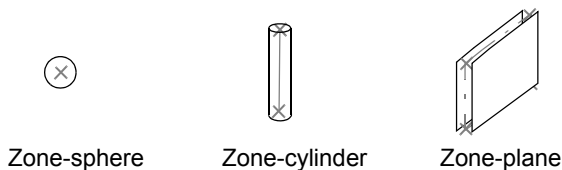

Figure 3: The Gauge-zones.

2.2 Construction of a compound gauge

The elementary gauges can be associated together to build more complex gauges called Compound Gauges.

Each elementary gauge is provided with a Cartesian frame which makes it possible to locate it in a single Cartesian frame of construction, which will become the Cartesian frame of the compound gauge. Thus, in its turn, the compound gauge can be used as component of a new compound gauge. The gauges can be compound indefinitely, nevertheless, from the practical point of view, a gauge of order 2, i.e. which contains a gauge compound of elementary gauges, is sufficient to check the most complicated standardized geometric tolerances.

2.3 "Fitting" behavior of the elementary gauges

Any elementary gauge seeks to be fitted as well as possible on the cloud of points with which it is associated.

For example, let us consider a gauge compound of two gauge-cylinders, parallel one to another and distant of 50 mm, each one being associated with a cloud of points representing a drilling.

If the two cylinders have fixed diameters, then the assembly of the compound gauge with the clouds of points can be impossible if drillings have too small diameter or if they are badly localised one towards another. If the assembly is possible, the compound gauge will take any assembled location with respect to the clouds of points (see Figure 4).

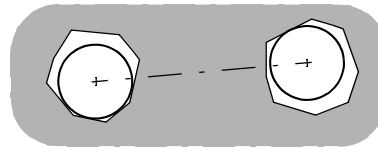

Figure 4: Assembly of a gauge compound of two cylinders with fixed diameters.

If one of the gauge-cylinders has a variable diameter, this one will take a maximum value compatible with the assembly of the compound gauge (see Figure 5).

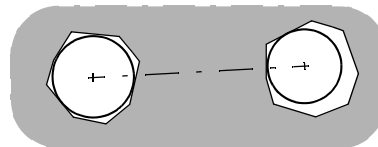

Figure 5: Assembly of a gauge compound of two cylinders which one has a variable diameter.

If the two gauges have variable diameters, they both will increase or decrease by the same quantity until the compound gauge does not have any more mobility compared to the clouds of points (except that of the translation along the axes of the gauges) (see Figure 6).

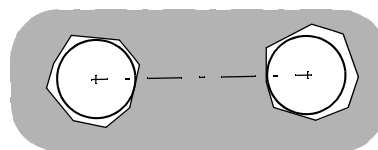

Figure 6: Assembly of a gauge compound of two cylinders with variable diameters.

2.4 Chronological order of the fits

It is possible to define a chronological order of fits of the components of a compound gauge. We define for that an attribute of priority which can be given to any gauge. This attribute can take the three following values: Primary-fitting, Secondary-fitting and Tertiary-fitting.

A primary-fitting gauge fits itself first by rigidly moving the compound gauge of which it is part. During this time the other gauges are neutralized so that they can be found temporarily not assembled with their clouds of points.

The fit of the primary-fitting gauge sets up a geometrical joint with its clouds of points. For example if it is a Cylinder, a cylindrical-joint is set up so that the compound gauge only has two degrees of freedom of movement left, the translation and rotation along the axis of the cylinder, to

permit to the other gauges to try to be assembled and to be fitted with their clouds of points.

An other gauge may take the following priority, Secondary-fitting, if its fit removes degrees of freedom of movement left to the compound gauge by the primary-fitting gauge. That depends at the same time on the class of this second gauge and of its location compared to the first gauge.

In the same way, a third gauge can take the priority tertiary-fitting if there remain degrees of freedom to the compound gauge which it can remove.

It is not necessary to envisage a fourth level of priority because no more degree of freedom can exist after the fit of the Tertiary-fitting gauge. The compound gauge is inevitably completely linked to the clouds of points. This can be shown thanks to the classes of surfaces [6]. Moreover according to the class of the primary-fitting and secondary-fitting gauges, the joint can be complete as soon as they are fitted. As soon as there are no more degrees of freedom for the compound gauge, it is not possible any more to give an under priority level to the others gauges, which all are fitting without priority and which will be fitted simultaneously after the priority-fitting gauges.

By definition, and to simplify the construction of the compound gauges, each of the three priority level can be given only to one component at the same time. If several gauges must be fitted simultaneously before the others, we will start by gathering them to constitute a first compound gauge which we will then use as a priority-fitting component in a new compound gauge.

2.5 Intrinsic mobilities of a component gauge

It is possible to allow a component gauge to move in translation and/or rotation along the axes of its cartesian frame starting from its initially definite location. Up to three translations and three rotations can be given to it. These mobilities make it possible to check the standardized orientation tolerances but also to measure the variations of location of surfaces of the part.

3. DEVELOPMENT OF A SOFTWARE OF METROLOGY BY FITTING GAUGES

We are currently developing an experimental software exploiting the model of the fitting gauges. This development is carried out in an commercial CAD environment in order to provide a three-dimensional display of the assembly of the gauges with the clouds of points, to offer all the awaited functionalities of a modern software package (back-up file, management of the modifications...) and, for the next versions, a strong integration with the CAD software (more or less automatic construction starting from the geometry of the part and its geometric tolerances). A first version should be proposed in 2009.

4. CHECKING BY FITTING GAUGES VS. TRADITIONAL CHECKING

4.1 Part example

In order to highlight the advantages of metrology by virtual fitting gauges compared to the traditional three-dimensional metrology, we will compare the inspection plans and the results of measurement obtained by these two metrologies for the same example part presenting several very current geometric tolerances in mechanics.

It consists in a prismatic experimental part which will be assembled by using its planar surface A and its two drillings B. A central boring must respect a positional tolerance compared to these first surfaces (voir Figure 7).

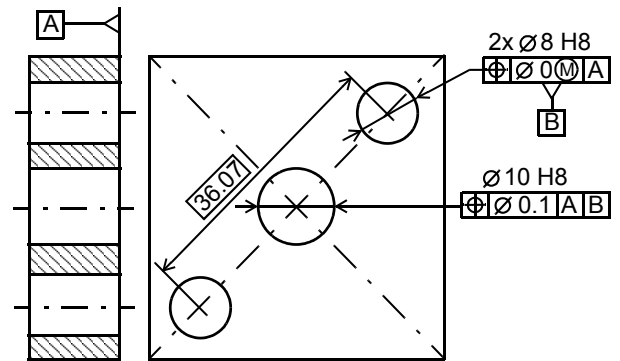

Figure 7: Tolerances of the experimental part.

The four elementary surfaces, the plane and three borings, are digitized individually in some points and the four corresponding clouds of points are stored in a file.

4.2 Inspection plan by traditional three-dimensional metrology

We present the least unfavourable plan for the acceptance of the part which can be made by traditional metrology. Let us note that the fact that several plans are possible for the same checks is a major disadvantage of traditional three-dimensional metrology.

Stage 1: Identification of elementary surfaces and construction of a Cartesian frame of the part

A plane of least squares is fitted with the cloud of points sampled on the surface A of the part. It is used to define the Z axis of the Cartesian frame of the part to be built.

A cylinder of least squares is fitted with each drilling of diameter 8. The axes of these two cylinders are limited by two points, one with its intersection with plane A, the other distant of 12mm from this plane. A point is built at the middle height on each one of these axes.

The two medium points are used to define the direction Y of the Cartesian frame of the part and the medium point of these two points enables to fix the origin of the Cartesian frame (see Figure 8).

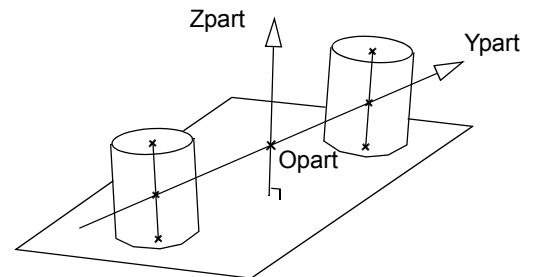

Figure 8: Identification of the surfaces and construction of a Cartesian frame of the part.

Stage 2: Inspection of the positional tolerance of drillings of diameter 8 :

Along the Y axis of the Cartesian frame of the part, a theoretical point is built for each cylinder at $(36.07 / 2)$ mm

into the positive and the negative direction. These two points represent the theoretical locations of the drillings.

The points at the ends of the axes of the cylinders are projected in the plane (X, O, Y) of the Cartesian frame of the part. The distances between these projected points and the theoretical points previously definite are measured. The positional defect is then the double of the maximum distance thus measured for each cylinder. This value is compared with a tolerance calculated for each cylinder by making the difference between its diameter and the diameter at the maximum material equal to 8 mm.

This inspection is approximate and does not lead to the same results than the inspection by material gauge reproducing the virtual condition of the drillings defined by the tolerance. In particular, it can result in rejecting a part conforme to the tolerance.

Stage 3: Inspection of the positional tolerance of the central boring of diameter 10 :

As for the cylinders of diameter 8, points are built on the axis of the cylinder of diameter 10 and are projected on the plane (X, O, Y) of the Cartesian frame of the part. The positional defect of the boring of diameter 10 is the double of the maximum distance between the projected points and the origin of the Cartesian frame. This value is compared with the tolerance of 0.1 mm.

The result of this inspection is close to that obtained by virtual gauge because the maximum material condition is not specified on the reference B. That would not have been so in the opposite case because the datum becomes "floating" which cannot be reproduced with the traditional software.

4.3 Inspection plan with fitting virtual gauges

Stage 1: Identification of elementary surfaces :

As for traditional three-dimensional metrology, a numerical theoretical surface is fitted on each sampled surface of the part. However these surfaces are outside of the material and are thus similar to elementary gauges fitted on their sampled surfaces. No Cartesian frame is built.

Stage 2: Inspection of the positional tolerance of drillings of diameter 8 :

In a Cartesian frame, initially coincident with the Cartesian frame of the sampled points, we build a compound gauge CG1, by the addition of a Primary-fitting Gauge-plane and of two fitting Gauge-cylinders of equal and variable diameters. These two gauge-cylinders are located in a symmetrical way compared to the origin of the Cartesian frame of construction (see Figure 9).

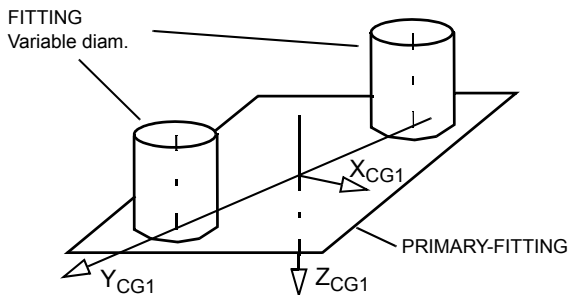

Figure 9: Compound gauge, CG1, for the inspection of the positional tolerance of the drillings of diameter 8 .

Once fitted, the gauge-plane leaves three degrees of freedom of displacement to the compound gauge. This makes it possible for the two Gauge-cylinders "to inflate" to the maximum inside the sampled drillings. The diameter that they take then must be larger than the diameter to the maximum material size defined by the tolerance, i.e. larger than 8 mm.

Stage 3: Inspection of the positional tolerance of the central boring of diameter 10 :

The tolerance relates to the axis of the boring of diameter 10. It is thus necessary to start by extracting a cloud of two points representing the ends of this axis. The method is similar technically with that employed in traditional three-dimensional metrology but it is automated by a menu of creation of an "extracted axis".

The secondary datum of the tolerance must be established simultaneously on two drillings diameter 8. The primary reference is the same one as the one of the previous tolerance, inspected with the compound gauge CG1. Also, it is possible to use this last compound gauge as a Primary-fitting component of the new gauge CG2 to be built. To finish the construction of gauge CG2, a Fitting Zone-cylinder just needs to be added yet at the origin of the Cartesian frame (see Figure 10).

Once that the component CG1 is fitted with the clouds of points, by respecting the chronology of fits defined between its own components (Gauge-plane at first then two gauge-cylinders simultaneously), the compound gauge CG2 does not have any more mobility left in respect to the part. The Zone-cylinder then will take the smallest diameter containing the two points, ends of the axis of the central cylinder. This diameter can directly be compared with the tolerance value of 0.1 mm.

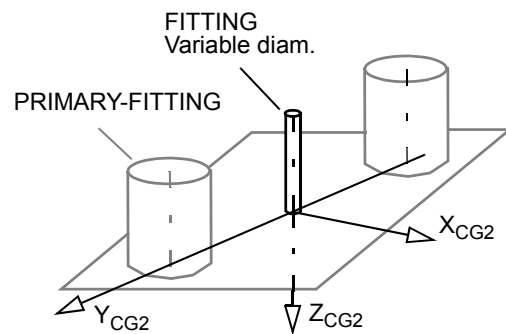

Figure 10: Compound gauge CG2, for the inspection of the positional tolerance of the boring of diameter 10.

4.4 Measuring of the location deviations of the central boring

One of the reproaches made to standardized tolerancing and to traditional three-dimensional metrology is that they do not allow to measure precisely the location deviations of the manufactured surfaces. Metrology by fitting gauges allows it, in a very precise and simple way. One just needs to give the gauge the mobilities corresponding to the components of location deviation that one wishes to measure. For example, by giving the Zone-cylinder of the previous gauge CG2, mobilities in translation and rotation according to axes X and Y of its Cartesian frame, the gauge will be able to fit itself onto the Extracted-cloud by taking a diameter equal to zero. The values of the components of mobility, Tx, Ty, Rx and Ry, are then

measured, which makes it possible to evaluate the eventual corrections that need to be made to the process carrying out the boring of diameter 10 (see Figure 11).

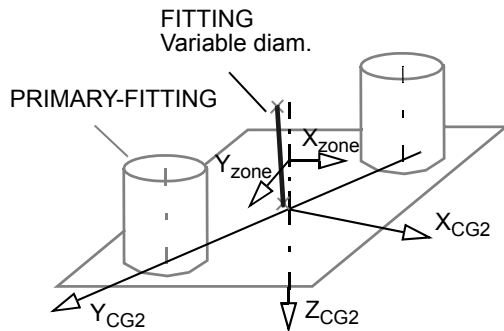

Figure 11: Compound gauge, CG3, for the measuring of the components of location deviation of the boring of diameter 10.

5. CONCLUSION AND PROSPECTS

As we have just illustrated it, metrology by the fitting gauges is simpler to use than traditional three-dimensional metrology. Indeed, this last one requires a rather great competence to convert the geometrical conditions, defined by geometric tolerances, into distances to be measured between features. A tolerance may be inspected differently according to the appraiser. This disadvantage does not exist with metrology by fitting gauges because the meaning of a geometric tolerance is normally single and the virtual checking gauge corresponds directly to this meaning.

Moreover the mobilities, left at the tolerance zones by the datum of the geometric tolerances cannot be reproduced with the traditional metrology. The virtual conditions cannot be reproduced either. Conversely, the fitting gauges integrate these mobilities automatically and make it possible to reproduce the virtual conditions. The consequence of these incapacities of the traditional software is that the inspections, which they allow, are more constraining than those defined by the geometric tolerances. The parts can then be rejected whereas they respect these last ones. This risk is eliminated with metrology by fitting gauges.

At the time we write these lines, a first version of a software of metrology by fitting gauges is about to be completed. It will enable us to show that on a series of 59 experimental parts, several are declared not good, by the traditional inspection plan presented in this article, and good by the inspection plan by virtual fitting gauges.

6. REFERENCES

- [1] ISO 8015:1985, "Technical drawings -- Fundamental tolerancing principle".
- [2] ASME Y14.5M-1994, "Dimensioning and Tolerancing".
- [3] Etesami F.; "Position Tolerance Verification Using Simulated Gaging", *The International Journal of Robotics Research*, Vol. 10, No. 4, 1991.
- [4] R. Jayaraman, V. Srinivasan, Geometric tolerancing: 1. Virtual boundary requirements, *IBM Journal of Research and Development*, Vol 33, N° 2, March 89.
- [5] E. Pairel, 1997, "The gauge model: A new approach for coordinate measurement", *Proceedings of the XIV*

IMEKO World Congress, Tampere, Finland, June, pp 278-283.

- [6] Briard, M., Charles, B., Clement, A., Pelissou, P., and Riviere, A., 1989, "The Mating Function in CAD/CAM Systems", *Proceedings of the Design Automation Conference, ASME Meeting, Canada*