



HAL
open science

Advanced Industrial Archaeology and Techno-Museology: A new virtual life for industrial heritage

Florent Laroche

► **To cite this version:**

Florent Laroche. Advanced Industrial Archaeology and Techno-Museology: A new virtual life for industrial heritage. TICCIH Bulletin, 2008, 41, pp.3-4. hal-00422346

HAL Id: hal-00422346

<https://hal.science/hal-00422346v1>

Submitted on 6 Oct 2009

HAL is a multi-disciplinary open access archive for the deposit and dissemination of scientific research documents, whether they are published or not. The documents may come from teaching and research institutions in France or abroad, or from public or private research centers.

L'archive ouverte pluridisciplinaire **HAL**, est destinée au dépôt et à la diffusion de documents scientifiques de niveau recherche, publiés ou non, émanant des établissements d'enseignement et de recherche français ou étrangers, des laboratoires publics ou privés.

Advanced Industrial Archaeology and Techno-Museology

A new virtual life for industrial heritage

Dr Florent Laroche
Ecole Centrale, Nantes, France

All through history humans have invented and created so as to improve their standard of living, many machines have been built; simple ones but also very complex others. Enterprise continuously adjusts its operating modes and its production tools to optimise its added value creation. Machines which are obsolete as soon as they don't meet the demand are stopped, stored and very often dismantled. Industrial sites disappear and the workers leave the industrial world taking their know-how with them.

To anticipate and avoid this loss to our scientific and technological knowledge an idea was pioneered by Professor Michel Cotte a few years ago [M. Cotte, S. Deniaud (2005), "CAO et patrimoine : perspectives innovantes", revue Archéologie industrielle en France, n°46, Paris, pp. 32-38]. Our team has since then formalised the methodology and tested it over more than ten case studies.

Moreover, we take note that the rescue and proper maintenance of physical objects is very costly for museums. Moreover, sometimes, dismantling of the equipment is impossible due to the deteriorated condition of the machine. So, avoid those problems, we propose to preserve it as a numerical object.

We focus on the mechanical and technical points of view. For instance, in a factory, there is the building itself but also all the equipment it contains. Taking into account the technical point of view can provide a better understanding of the past. Consequently, engineers and industrial engineering tools and methods can give answers for capitalising knowledge, conserving and popularising old machines. Even so, the work of historians is not discarded. Researches for a better understanding of the socio-ethno-historical context of the object are necessary for formalising and validating technical hypotheses.

It is a new way of thinking about heritage projects: social sciences and engineering sciences must merge together. Tools and methods from both domains have to fit and to interact as shown by the puzzle figure below.

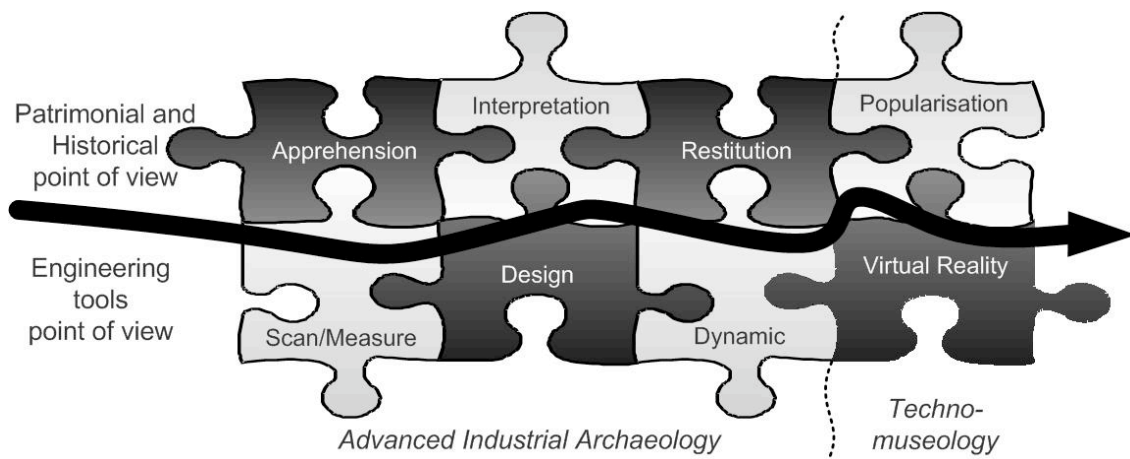

Our proposition consists in overturning the time axis of the design process generally used for developing contemporary technical products. That means that we begin at the end of machine lifetime and come back to the initial need that define why the technical object had been created. First step is the digitalisation of the physical object and the capitalisation of the know-how learnt by studying the machine. Next, thanks to virtual reality technologies, we can valorise this amount of knowledge. This global process is what we call Advanced Industrial Archaeology.

First of all, if physical data exists it must be captured. The basic tools are decametres, slide callipers, micrometer callipers. However, 3D digitalisation can be employed for measuring complex machines or inaccessible components inside the object: TMM (Tridimensionnal Measuring Machines), laser radar, X-ray, 3D scanner laser with topographical reconstruction in real-time. Those contemporary industrial tools must be chosen carefully as the gait is not the same when digitalising ancient objects and modern industrial products. For example, to avoid damaging a machine, contact can sometimes be impossible or even forbidden: technology used must be without contact based on a passive system. Main difference between passive and active systems is due to the technology that emits a light beam or not.

Simultaneously, Knowledge Management methods which are commonly used by businesses must be coupled to historical studies. This step allows capitalising external knowledge, identifying know-how of workers, giving information about suppliers or customers, etc.

Next, the technical object and its environment are re-designed thanks to Computer Aided Design (CAD) software. Those programmes are commonly used by modern industries for designing complex products

such as airplanes or cars. Considered as experimental researches or didactic applications, our teams use Catia V5 by Dassault Systèmes (the same software used for developing the Airbus A380 aircraft). Moreover, even though old objects are mainly inert, they were animated by mechanisms. Consequently, they have to be virtually restored and simulated in order to validate the operating of the machine. At this step, we prefer to use CAD programmes instead of Computer Graphics programmes (CG). These are employed for creating animated pictures, movies, etc. With CG programmes, simulations and dynamics are not realistic. An entire "virtual world" is created in which objects move. But this world does not have the properties of the terrestrial physical laws such as the fundamental principles of mechanics (for example gravity, stress, speed, acceleration).

Then this heritage engineering phase allows obtaining what businesses call Digital Mock-Up (DMU). Nowadays, the digital model of a product is the principal element for industrial production. DMU is the converging point for organising departments of an enterprise: Research & Development, design, manufacturing, marketing, sales, etc. In the same way, the virtual representation of an old technical object can be associated, linked and enriched thanks to external cultural knowledge and anthropological know-how: it is what we call the Digital Heritage Reference Model (DHRM). This Technical Heritage File allows capitalising knowledge from the past into a digital media and a virtual simulating state. Thus, the DMU can become a new museological tool and a reference model for museum curators. Obviously we must insist that digital files will never replace physical objects. The DMU is only another way to represent reality: it widened the definition of the Artefact.

Obviously, the value of using digital representation is intended to experts or museum curators. But it has other applications...

Old machines do not usually function or cannot be exhibited in a museum due to problems of cost and security (component wear, machine driver requirement, etc.). Nowadays, thanks to virtual reality technologies, the DHRM can be used to present the artefact. Unlike videos and thanks to interactivity, it is easier to understand how they work: the visitor is no longer a spectator but an actor. Virtual Reality is a new mediation tool that allows visitors to immerse themselves in a virtual environment: the machine can be tested virtually to its extreme limits; the level of detail can be adapted by the museum according to the targeted public, etc. Indeed, it lets visitors investigating themselves the technical system from their own point of view (global immersion, technical analyses, local study of components, social integration of the technical environment, etc.).

Understanding an old technological object can be easy for former workers but it can be difficult for curators or visitors of their museums. Virtual Reality tools can become a springboard for ensuring that the know-how of our scientific and technical industrial heritage will be apprehensible and comprehensible by everyone. This is the next step after Advanced Industrial Archaeology: we call it Techno-Museology, a new kind of museology for this 3rd millennium.

The images below show two of the experiences we have performed in France. The input data of the study was one drawing of a steamboat designed in 1861 by DCNS (latitude 47°11'47 North and longitude 1°41'00 West). The other example is a salt washing machine (c.1914-1963) belonging to the Musée des Marais Salants in Batz-sur-Mer in Brittany (latitude 47°16'44 North and longitude 2°28'41 West).

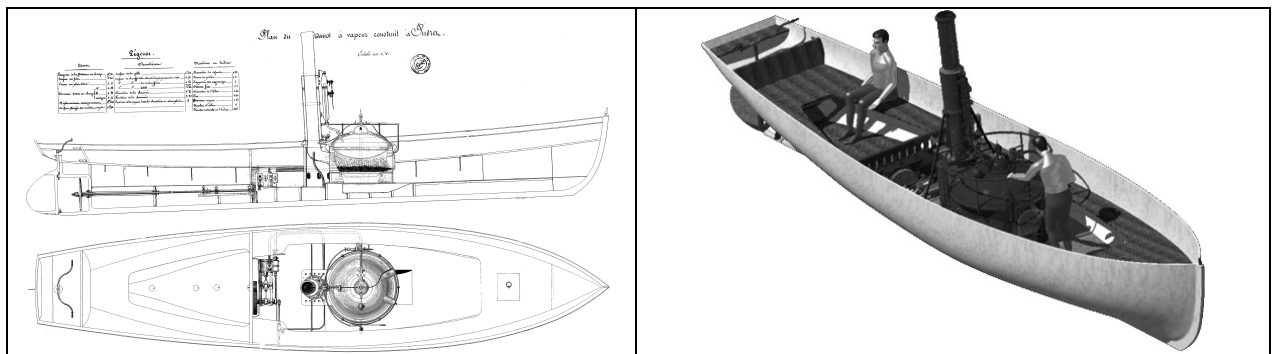

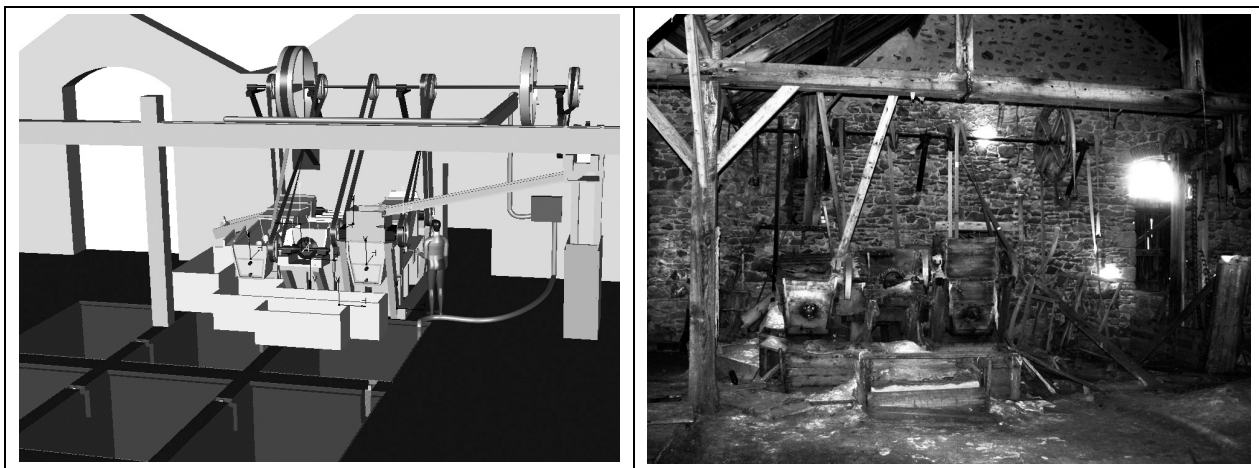

Dr Florent Laroche, Ecole Centrale, IRCCyN, 1 rue de la Noë, 44000 NANTES
florent.laroche@irccyn.ec-nantes.fr
<http://florent.laroche.free.fr>