



HAL
open science

A survey of topics in analysis and differential equations

Denise Huet

► **To cite this version:**

Denise Huet. A survey of topics in analysis and differential equations. International Journal of Pure and Applied Mathematics, 2010, 62 (1), pp.79-128. hal-00394244

HAL Id: hal-00394244

<https://hal.science/hal-00394244>

Submitted on 11 Jun 2009

HAL is a multi-disciplinary open access archive for the deposit and dissemination of scientific research documents, whether they are published or not. The documents may come from teaching and research institutions in France or abroad, or from public or private research centers.

L'archive ouverte pluridisciplinaire **HAL**, est destinée au dépôt et à la diffusion de documents scientifiques de niveau recherche, publiés ou non, émanant des établissements d'enseignement et de recherche français ou étrangers, des laboratoires publics ou privés.

A survey of topics in analysis and differential equations

Denise Huet
INSTITUT ELIE CARTAN NANCY
Universite Henri Poincare Nancy 1 B.P. 239
54506 Vandoeuvre les Nancy Cedex, FRANCE
Denise.Huet@iecn.u-nancy.fr

June 4, 2009

Abstract

This survey (or essay) is the result of reflexions suggested by recent publications. The topics, which are dealt with, are related to linear or nonlinear evolution equations, of first or second order in the time-variable, linear and nonlinear elliptic equations, spectral properties, singular perturbations, formation of layers, and spaces of functions, in particular of BMO or Sobolev type. They are presented in the alphabetical order, so that the article can be used as a dictionary. The aim of this document is to provide guidance for (young) researchers in mathematics and applied sciences, biology, chemistry, mechanics and physics.

AMS Subject Classification: 3502; 4602; 4702.

Key Words and Phrases: Attractors; Fractals; Evolution equations and systems; Elliptic equations; Schrödinger operator; Spectral theory; Singular perturbations; Internal and boundary layers; Spaces of functions.

Introduction

For convenience, the article is divided into two sections as follows

Contents

1	From Attractor to Hyperbolic secant	3
1.1	Attractor	3
1.2	Aubry-type sets	6

1.3	Birman-Schwinger operator	7
1.4	BMO and related spaces	8
1.5	Bounded variation (functions of)	9
1.6	Cahn-Hilliard-Gurtin equation	10
1.7	Dimensions in a metric space	11
1.8	Dirac operator	12
1.9	Distances	14
1.10	Equal- area condition	14
1.11	Fokker-Planck equation	16
1.12	Gierer-Meinhardt system	19
1.13	Gray-Scott systems	19
1.14	Hyperbolic secant	20
2	From Kirchoff-type equations to Wavefront sets	21
2.1	Kirchoff-type equations	21
2.2	Lyusternik-Schnirelman category	23
2.3	Mathieu-Hill type equations	24
2.4	Memory (equations with)	25
2.5	Moser-Trudinger inequality	26
2.6	Moving planes and sliding methods	26
2.7	N-mode solution	28
2.8	Nodal	28
2.9	Nonlocal eigenvalue problem	29
2.10	Quasi-periodic Schrödinger operator	29
2.11	Resonances	30
2.12	Scattering metric	31
2.13	Sobolev-type spaces $M^{1,p}$ on metric-measure spaces	32
2.14	Steklov eigenproblems	33
2.15	Strichartz-type inequality	34
2.16	Trace space $H^s(\partial\Omega)$: an intrinsic Steklov eigenfunction expansion definition	35
2.17	Trudinger condition	35
2.18	Ultraparabolic equations	36
2.19	Virtual eigenvalue	37
2.20	Wavefront sets	37

The development of each entry is, of course, non exhaustive. The main ones include history, definitions, an overview of main results, examples or applications; details and complements will be found in the references.

1 From Attractor to Hyperbolic secant

1.1 Attractor

1.1.1 Attractor of an iterated function system in fractal geometry

See K. Falconer [42] and [43]. Let X be a closed subset of \mathbb{R}^n . An **iterated function system** is a family of contractions $\{F_1, \dots, F_m\}$ on X , $m \geq 2$. Let (S, d) be the complete metric space of compact subsets of X equipped with the distance

$$d(A, B) = \inf\{\delta : A \subset B_\delta \text{ and } B \subset A_\delta\}$$

where A_δ is a δ -neighbourhood of A , and define the map

$$A \in S \rightarrow F(A) = \bigcup_{i=1}^m F_i(A) \in S$$

Then, F is a contraction, and thanks to the fixed point theorem (cf. L. Schwartz [88]) there exists a unique compact set $E \in S$ such that

$$F(E) = \bigcup_{i=1}^m F_i(E) = E.$$

The compact set E , which is often a fractal set, is called the **attractor** of the iterated function system $\{F_1, \dots, F_m\}$. Moreover, for all $A \in S$, $F^k(A) \rightarrow E$ for the metric d , as $k \rightarrow \infty$, and

$$F(E) = \bigcap_{k=1}^{\infty} F^k(A)$$

for all $A \in S$, such that $F_i(A) \subset A$ for all i . The sets $E_k = F^k(A)$ are called **pre-fractals** for E .

Example 1:

$X = [0, 1]$, $F_1(x) = \frac{1}{3}x$, $F_2(x) = \frac{1}{3}x + \frac{2}{3}$. Then, the attractor of the system $\{F_1, F_2\}$ is the Cantor set (cf. E.C. Titchmarsh [95] and Figure 1)



Figure 1. The Cantor set

1.1.2 Global attractor for an autonomous evolution equation

Definition 1. Let

$$\partial_t u(x, t) = A(u(x, t)), \tag{1}$$

be the abstract form of an autonomous evolution equation. It is assumed that the Cauchy problem (1) has a unique solution. Here u_o and $u(x, t), \forall t \geq 0$, belong, for example, to a Banach or metric space E . Let $\{S(t)\} = \{S(t), \forall t \geq 0\}$ be the corresponding (nonlinear) semigroup of operators such that $u(x, t) = S(t)u_o(x), \forall t \geq 0$. A set $\mathcal{A} \subset E$ is a *global attractor* of (1) or of $\{S(t)\}$ if \mathcal{A} is compact, $S(t)\mathcal{A} = \mathcal{A}, \forall t \geq 0$, and for each bounded set $B \subset E$, \mathcal{A} attracts B , i.e. $dist_E(S(t)B, \mathcal{A}) \rightarrow 0$ as $t \rightarrow \infty$, where $dist_E$ denotes the Hausdorff semi-distance (cf. section 1.9). In fact, \mathcal{A} attracts the solutions $u(x, t) = S(t)u_o(x)$ to (1) as $t \rightarrow \infty$, uniformly with respect to bounded initial data $u_o(x)$. The global attractor of equation (1) describes all the possible limits of its solutions (cf. V.V. Chepyzhov, M.I. Vishik [23])

Example 2

In [7], S. Amraoui and H. Labani study the following reaction-diffusion system:

$$\frac{\partial u_i}{\partial t} - d_i \Delta u_i = f_i(u) \text{ in } \Omega \times]0, T[, 1 \leq i \leq 3 \quad (2)$$

associated with the boundary condition

$$(1-\lambda)u_i(t, x) + \lambda \frac{\partial u_i}{\partial \nu}(x, t) = \alpha_i(x), x \in \gamma, t \in]0, T[, 1 \leq i \leq 3, 0 \leq \lambda < 1, \quad (3)$$

and the initial condition

$$u(x, 0) = u_o(x) \quad x \in \Omega, \quad (4)$$

where Ω is a bounded subset of $\mathbb{R}^n, n \geq 1$, with a smooth boundary $\gamma, T > 0, u_i \geq 0, d_i > 0, f_1(u) = f_2(u) = -f_3(u) = u_3 - u_1 u_2, \alpha_i(x) > 0$. Under suitable hypotheses on the data, they construct a global attractor $\mathcal{M} \subset E$ of the system (2)-(4), where $E = \{v = (v_1, v_2, v_3) \in (L^\infty(\Omega))^3, v_i \geq 0, 1 \leq i \leq 3\}$ equipped with the norm $\sum_{i=1}^3 \|v_i\|_\infty$

1.1.3 Exponential attractors

1.1.3.1 The Hilbert space case

Definition 2. Let H be a **Hilbert space**, and \mathcal{A} be the global attractor of a semigroup of operators $S(t)$ in H . Let $\chi \subset H$ be a compact invariant set containing \mathcal{A} . A compact set $\mathcal{E} \subset \chi$ is called **an exponential attractor** for $S(t)$ restricted to χ if: i) \mathcal{E} is invariant for $S(t)$, ii) The fractal dimension (cf. section 1.7) of \mathcal{E} in H is finite, iii) There exist $K_\chi \geq 0$ and $\epsilon_\chi > 0$ such that $dist_H(S(t)\chi, \mathcal{E}) \leq K_\chi e^{-\epsilon_\chi t}, t \geq 0$. The set χ is called the basin of attraction of \mathcal{E} (see S. Gatti, M. Grasselli, V. Pata [47]).

Example 3

In [25], M. Conti, V. Pata and M. Squassina are interested in the convergence, in an appropriate sense, as $\epsilon \rightarrow 0$, of the solution $u_\epsilon(x, t)$, $x \in \Omega$, $t \in \mathbb{R}$ to problem (p_ϵ) :

$$u_t - \omega \Delta u - (1 - \omega) \int_0^\infty k_\epsilon(s) \Delta u(t - s) ds + \varphi(u) = f, \quad t > 0,$$

with Dirichlet boundary conditions on the boundary of the smooth bounded domain Ω in \mathbb{R}^3 , $\omega > 0$, φ is a suitable nonlinearity, f is a time independent source term, and the memory kernel k_ϵ converges to the Dirac distribution at the origin (see section 2.4), $u(x, t)$ is supposed to be a given datum for $t \leq 0$. Let $A = -\Delta$ on $L^2(\Omega)$ with domain $\mathcal{D}(A) = H_o^1(\Omega) \cap H^2(\Omega)$, $H^r = \mathcal{D}(A^{\frac{r}{2}})$, $r \in \mathbb{R}$. Following C. Dafermos [29] and M. Grasselli and V. Pata [51], they introduce, under additional assumptions on k, φ, f , ($\varphi(x) = x^3 - x$ is allowed), the auxiliary variable $\eta^t(x, s) = \int_o^s u(x, t - y) dy$, the functions $\mu(s) = -(1 - \omega)k'(s)$, $\mu_\epsilon(s) = \frac{1}{\epsilon^2} \mu(\frac{s}{\epsilon})$, the Hilbert spaces $\mathcal{M}_\epsilon^r = L_{\mu_\epsilon}^2(\mathbb{R}^+, H^{r+1})$ and $\mathcal{H}_\epsilon^r = H^r \times \mathcal{M}_\epsilon^r$ for $\epsilon > 0$, $\mathcal{H}_o^r = H^r$. The correct reformulation of p_ϵ , in the frame work of dynamical systems, is (P_ϵ) : find $(u_\epsilon, \eta_\epsilon) \in C([0, \infty), \mathcal{H}_\epsilon^o)$ solution to

$$u_t + \omega Au + \int_o^\infty \mu_\epsilon(s) A \eta(s) ds + \varphi(u) = f, \quad \partial_t \eta = -\partial_s \eta + u$$

for $t > 0$, associated with the initial condition $(u_o, \eta_o) \in \mathcal{H}_\epsilon^o$. The existence, for $\epsilon > 0$, of a strongly continuous semi-group $S_\epsilon(t)$ on \mathcal{H}_ϵ^o corresponding to P_ϵ and of an exponential attractor \mathcal{E}_ϵ for $S_\epsilon(t)$ are proved. The convergence of \mathcal{E}_ϵ is also studied.

1.1.3.2 The metric space case

Definition 3. Let E be a metric space, X be a compact subset of E and $\{S(t)\}_{t \geq 0}$ be a continuous semi-group on E . A compact set \mathcal{M} is called an exponential attractor for $S(t)$ for the topology of E if $S(t)\mathcal{M} \subset \mathcal{M}$, $\forall t \geq 0$, the fractal dimension of \mathcal{M} is finite, and there exists a constant $c > 0$ such that, for every bounded set $B \subset X$ there exists a constant $c_1(B)$ such that:

$$\text{dist}_E(S(t)B, \mathcal{M}) \leq c_1 e^{-ct} \quad \forall t \geq 0$$

(see A. Bonfioh, M. Grasselli, A. Miranville [18]).

Example 4: The Cahn-Hilliard-Gurtin equation

In [18], the authors study the Cahn-Hilliard-Gurtin type problem

$$A\rho = \frac{\partial \rho}{\partial t} - \mathbf{d} \cdot \nabla \frac{\partial \rho}{\partial t} - \text{div} \left(\tilde{B} \nabla \frac{\partial \rho}{\partial t} - \alpha B \nabla \Delta \rho + B \nabla f'(\rho) \right) = 0 \quad (5)$$

on $\Omega = \prod_{i=1}^n (0, L_i)$, $L_i > 0$, $n \leq 3$, [resp. its singular perturbed problem

$$\epsilon \frac{\partial^2 \rho}{\partial t^2} + A\rho = 0 \tag{6}$$

associated with the conditions : ρ is Ω - periodic and

$$\rho|_{t=0} = \rho_0, \tag{7}$$

[resp (7) and $\frac{\partial \rho}{\partial t} = \rho_1$]. Here $\mathbf{d} \in \mathbb{R}^n$, $\alpha > 0$, B, \tilde{B} , are two positive definite $n \times n$ matrices with constant coefficients and f is a double-well-like potential. They prove the existence of a family of exponential attractors \mathcal{M}_ϵ in the Banach space $\mathcal{H}_\epsilon = H_{per}^1 \times (H_{per}^1)'$ equipped with a norm which depends on ϵ , for the semigroup $S_\epsilon(t)$ associated to the perturbed problem and study the convergence of \mathcal{M}_ϵ to an exponential attractor associated to the unperturbed problem (5)-(7). See, also, the examples in section 1.6

1.2 Aubry-type sets

1.2.1 History

Aubry-type sets are a part of the Aubry-Mather theory. A good introduction to the theory can be found in O. Knill [64]. An historic of the theory, which started in 1924 with M. Morse [77], and perspectives of new developments in different domains of mathematics and physics are presented in the review , by V. Bangert [12], of the lecture notes [64].

1.2.2 Applications to elliptic perturbations of Hamilton-Jacobi equations

In [22], F. Camilli and A. Cesaroni consider the singular perturbation problem

$$\begin{cases} -\epsilon \Delta v_\epsilon + H(x, \nabla v_\epsilon) - \epsilon c(x) = 0 & \text{in } D \\ v_\epsilon = g(x) & \text{on } \partial D \end{cases} \tag{8}$$

under the following assumptions: D is a bounded set with Lipschitz boundary in \mathbb{R}^n , $H(x, p)$ is a continuous, Lipschitz continuous in x , convex and coercive in p Hamiltonian, $H(x, 0) \leq 0$ and the critical value of H is 0, $c : \bar{D} \rightarrow \mathbb{R}$ is a continuous nonnegative function, g is a continuous function on $\partial\Omega$. The limit problem i.e. the Hamilton-Jacobi problem:

$$\begin{cases} H(x, \nabla v) = 0 & \text{in } D, \\ v(x) = g(x) & \text{on } \partial D \end{cases} \tag{9}$$

has, in general, many viscosity solutions (cf. P.L. Lions [70]). As in several previous papers, in particular A. Eizenberg [37], A. Siconolfi [90], and A. Fathi, A.

Siconolfi [44], the authors introduce the convex set $Z(x) = \{p \in \mathbb{R}^n | H(x, p) \leq 0\}$, $x \in \overline{D}$, the support function $\sigma(x, \cdot)$ of $Z(x)$ and the distance

$$S(x, y) = \inf \left\{ \int_0^1 \sigma(\Phi(s), \dot{\Phi}(s)) ds, \quad \Phi \in \mathcal{C}_{x,y} \right\},$$

where $\mathcal{C}_{x,y}$ is the set of $W^{1,\infty}([0, 1], D)$ curves such that $\Phi(0) = x, \Phi(1) = y$. They give the following **definition of the Aubry-type set \mathcal{A} associated to problem (9)**: a point $x \in \mathcal{A}$, if there exists a sequence $\Phi_n \in \mathcal{C}_{x,x}$ whose Euclidean length l satisfies $l(\Phi_n) \geq \delta > 0$ and whose length with respect to σ vanishes i.e. $\inf_n \left\{ \int_0^1 \sigma(\dot{\Phi}_n(s), \dot{\Phi}_n(s)) ds \right\} = 0$. In fact, **\mathcal{A} behaves as an hidden boundary on which a datum must be fixed to have existence and uniqueness for problem (9)**. Namely if g is a real function, defined and continuous on $\partial D \cup \mathcal{A}$, such that $-S(y, x) \leq g(x) - g(y) \leq S(y, x)$ for $x, y \in \partial D \cup \mathcal{A}$, there exists a unique viscosity solution u to (9) such that $u(x) = g(x)$ on $\partial D \cup \mathcal{A}$. Moreover, if \mathcal{A} satisfies additional conditions, and if ∇v_ϵ is bounded by a constant independent of ϵ , then v_ϵ , solution to (8), converges uniformly to the maximal viscosity solution $G(x) = \min_{y \in \partial D} \{g(y) + S(y, x)\}$ to (9), as $\epsilon \rightarrow 0$.

Examples of hamiltonians of the forms $H(x, p) = \frac{|p|^2}{2} - b(x) \cdot p$, $H(x, p) = -b(x) \cdot p + K(x, p)$, and the Eikonal Hamiltonian $H(x, p) = F(p) - f(x)$, for which the above results hold, are investigated.

1.3 Birman-Schwinger operator

Definition 4. Consider the Schrödinger operator

$$H_\gamma = H_o + \gamma V(x), H_o = (-\Delta)^l \tag{10}$$

acting on $L^2(\mathbb{R}^d)$, $2l \geq d$, where $x \rightarrow V(x)$ is a real-valued continuous function defined on \mathbb{R}^d which is non-negative, and tends to zero sufficiently fast as $|x| \rightarrow \infty$, γ is a small negative coupling constant. The operator H_o is self adjoint and its spectrum is $\sigma_o = [0, +\infty)$. The **Birman-Schwinger** operator associated to (10) is the operator

$$X_V(\lambda) = V^{\frac{1}{2}} R_\lambda(H_o) V^{\frac{1}{2}},$$

where $R_\lambda(H_o)$ is the resolvent of H_o in $(-\infty, 0)$. For each $\lambda \in (-\infty, 0)$, $X_V(\lambda)$ is self adjoint and compact (cf. J. Arazy, L. Zelenko [8]).

1.3.1 Application

In [8], the authors consider the decomposition $X_V(\lambda) = \Phi(\lambda) + T(\lambda)$, where $\Phi(\lambda)$ is a finite rank operator and $T(\lambda)$ an Hilbert-Schmidt operator whose norm is uniformly bounded with respect to $\lambda \in (-\delta, 0)$ for some $\delta > 0$. An

asymptotic expansion of the bottom virtual eigenvalue $\lambda_o(\gamma)$ of H_γ , as $\gamma < 0$ tends to zero, is deduced from this decomposition: if d is odd, it is of power type, while, when d is even, it involves the log function. Asymptotic estimates are obtained, as $\gamma \uparrow 0$, for the non-bottom virtual eigenvalues of H_γ , $\{\lambda_{\mathbf{k}}(\gamma), \mathbf{k} \in \mathbb{Z}_+^d; 0 < |\mathbf{k}| \leq m\}$, where $m = l - \frac{d+1}{2}$ if d is odd and $m = l - \frac{d}{2}$ if d is even. If d is odd, $\Phi(-t^{2l})$ is a meromorphic operator function, and the leading terms of the asymptotic estimates of $\lambda_{\mathbf{k}}(\gamma)$ are of power type. An algorithm, based on the Puiseux-Newton diagram (cf. H. Baumgärtel [14]), is proposed for an evaluation of the leading coefficients of these estimates. If d is even, two-sided estimates are obtained for eigenvalues with an exponential rate of decay; the rest of the eigenvalues have a power rate of decay. Estimates of Lieb-Thirring type are obtained for groups of eigenvalues which have the same rate of decay, when d is odd or even.

1.4 BMO and related spaces

1.4.1 Definitions

The definitions of the following spaces are recalled in J. Xiao [100].

1.4.1.1 BMO space Let \sup_I be the supremum over all cubes $I \subset \mathbb{R}^n$ with edges parallel to the coordinate axes, $\ell(I)$ be the sidelength of I and f_I the mean value of f over I . The square form of John-Nirenberg's $BMO = BMO(\mathbb{R}^n)$ space (cf. F. John, L. Nirenberg [60]) is the space of locally integrable complex-valued functions f defined on \mathbb{R}^n , $n \geq 2$, such that

$$\|f\|_{BMO} = \left(\sup_I (\ell(I))^{-n} \int_I |f(x) - f_I|^2 dx \right)^{\frac{1}{2}} < \infty.$$

1.4.1.2 \mathcal{Q}_α spaces For $\alpha \in (-\infty, \infty)$, $\mathcal{Q}_\alpha(\mathbb{R}^n)$ is the Banach space of all measurable complex-valued functions on \mathbb{R}^n , modulo constants, such that

$$\|f\|_{\mathcal{Q}_\alpha} = \sup_I \left((\ell(I))^{2\alpha-n} \int_I \int_I \frac{|f(x) - f(y)|^2}{|x - y|^{n+2\alpha}} dx dy \right)^{\frac{1}{2}} < \infty.$$

(cf. M. Essen, S. Janson, L. Peng, J. Xiao [40]).

1.4.1.3 \dot{L}_α^2 , $\alpha \in (0, 1)$ The homogeneous Sobolev space $\dot{L}_\alpha^2(\mathbb{R}^n)$ is the space of complex-valued functions f such that

$$\|f\|_{\dot{L}_\alpha^2} = \left(\int_{\mathbb{R}^n} \int_{\mathbb{R}^n} \frac{|f(x) - f(y)|^2}{|x - y|^{n+2\alpha}} dx dy \right)^{\frac{1}{2}} < \infty$$

1.4.1.4 $\mathcal{L}_{2,n-2\alpha}$, $\alpha \in (0,1)$. It is the space of measurable complex-valued functions f on \mathbb{R}^n such that

$$\|f\|_{\mathcal{L}_{2,n-2\alpha}} = \sup_I \left(\ell(I)^{2\alpha-n} \int_I |f(x) - f_I|^2 dx \right)^{\frac{1}{2}} < \infty$$

1.4.1.5 Space $\mathcal{Q}_{\alpha;T}^{-1}$, $\alpha \in (0,1), T \in (0, \infty)$ A tempered distribution f on \mathbb{R}^n belongs to this space provided

$$\|f\|_{\mathcal{Q}_{\alpha;T}^{-1}} = \sup_{x \in \mathbb{R}^n, r \in (0,T)} \left(r^{2\alpha-n} \int_0^{r^2} \int_{|y-x|<r} |e^{t\Delta} f(y)|^2 t^{-\alpha} dy dt \right)^{\frac{1}{2}} < \infty$$

where $e^{t\Delta}(x, y)$ is the heat kernel.

1.4.2 Relations between these spaces

For $\alpha \in \mathbb{R}, f \in \mathcal{S}'(\mathbb{R}^n)$, modulo polynomials, $(-\Delta)^{-\frac{\alpha}{2}} f = \mathcal{F}^{-1}(|\xi|^{-\alpha} \hat{f}(\xi)) = I_{\alpha} f$ (cf. R. Strichartz [93]). In [100], when $\alpha \in (0,1)$, it is proved that 1) $\mathcal{Q}_{\alpha} = (-\Delta)^{-\frac{\alpha}{2}} \mathcal{L}_{2,n-2\alpha}$, 2) $\dot{L}_{\alpha}^2 = (-\Delta)^{-\frac{\alpha}{2}} L^2$, 3) $\mathcal{Q}_{\alpha;\infty}^{-1} = \nabla \cdot (\mathcal{Q}_{\alpha})^n$ and sharp estimates for the norms of the embeddings $\mathcal{Q}_{\alpha} \hookrightarrow BMO$, and $\dot{L}_{\alpha}^2 \hookrightarrow L^{\frac{2n}{n-2\alpha}}$, are obtained. We point out that 3) means that $f \in \mathcal{Q}_{\alpha;\infty}^{-1}$ if and only if there are $f_j \in \mathcal{Q}_{\alpha}$ such that $f = \sum_{j=1}^n \partial_j f_j$.

1.5 Bounded variation (functions of)

Several equivalent definitions of functions of bounded variation are well known (see e.g. E.C. Titchmarsh [95] and H. Brezis [19]). Let $\Omega \subset \mathbb{R}^d$ be an open set with a smooth boundary.

1.5.1 Space $BV(\Omega, \mathbb{R}^q)$

A function $f \in L^1_{loc}(\Omega, \mathbb{R}^q)$ has a bounded variation i.e. $f \in BV(\Omega, \mathbb{R}^q)$, if ∇f is a Radon measure of finite total mass. Let $|\mathbf{f}|_{\mathbf{BV}} = \int_{\Omega} |\nabla \mathbf{f}|$ be a **BV-semi-norm**. In J. Davila [31], the following property of $|f|_{BV}$ is proved: there exists a positive constant K , which depends on d , such that, for every family of non negative radial mollifiers $\rho_{\epsilon} \in L^1_{loc}((0, \infty), \mathbb{R}_+)$ satisfying

$$\int_0^{\infty} \rho_{\epsilon}(r) r^{d-1} dr = 1 \text{ and } \lim_{\epsilon \rightarrow 0} \int_{\delta}^{\infty} \rho_{\epsilon}(r) r^{d-1} dr = 0 \quad \forall \delta > 0,$$

we have

$$\lim_{\epsilon \rightarrow 0} \int_{\Omega^2} \frac{|f(x) - f(y)|}{|x - y|} \rho_\epsilon(|x - y|) dx dy = K|f|_{BV}, \quad \forall f \in BV(\Omega, \mathbb{R}^q).$$

1.5.2 Application

In [75], B. Merlet shows, by means of the above property of $|f|_{BV}$, that, if $u \in BV(\Omega, S^1)$, there exists a lifting $\varphi \in BV(\Omega, \mathbb{R})$ of u (i.e. $u(x) = e^{i\varphi(x)}, \forall x \in \Omega$) such that $|\varphi|_{BV} \leq 2|u|_{BV}$.

1.6 Cahn-Hilliard-Gurtin equation

After the initial Cahn-Hilliard equation:

$$\frac{\partial \rho}{\partial t} = \kappa \Delta [f'(\rho) - \alpha \Delta \rho],$$

$\alpha > 0, \kappa > 0$, which governs the evolution of the order parameter $\rho(x, t)$, where $f(\rho)$ is the coarse-grain free energy. (cf. J.W. Cahn [20]), generalized in M.E. Gurtin [52], several generalizations have been studied, mostly in relation with attractors and singular perturbations.

Example 5

In [32], A. Debussche, studies the Cahn-Hilliard problem (P)

$$Au = \frac{\partial u}{\partial t} + \nu \Delta^2 u - \Delta f(u) = 0 \quad \text{in } \Omega \times \mathbb{R}^+$$

where $u(x, t)$ is a real-valued function, $\Omega = [0, L]$ and f is a polynomial of even order whose leading coefficient is positive, supplemented with an initial condition u_o and Neumann or periodic boundary conditions. He considers the perturbed problem (P_ϵ) :

$$\epsilon \frac{\partial^2 u}{\partial t^2} + Au = 0$$

associated with the same boundary conditions, the initial condition u_o and $\frac{\partial u}{\partial t} = u_1(x)$. He studies the existence of a global attractor \mathcal{A}_ϵ for (P_ϵ) and its convergence to the global attractor of (P), in suitable functional spaces.

Example 6

In [48], S. Gatti, M. Grasselli, A. Miranville and V. Pata study the following initial and boundary value problem :

$$\omega u_{tt} + u_t - \Delta(-\Delta u + \phi(u) + \delta u) = 0, \quad \text{in } \Omega \times \mathbb{R}^+ \quad (11)$$

associated with the initial conditions

$$u(0) = u_o, \quad \omega u_t(0) = \omega u_1 \quad (12)$$

and the boundary condition

$$u|_{\partial\Omega} = \Delta u|_{\partial\Omega} = 0 \quad (13)$$

where Ω is a bounded domain in \mathbb{R}^3 , with a smooth boundary $\partial\Omega$, $\omega, \delta \in [0, 1]$, $\delta \geq \mu\omega$ with $\mu \in (0, 1]$, and ϕ is a smooth function with cubic controlled growth. If $\omega = \delta = 0$, equation (11) is the Cahn-Hilliard equation, if $\omega = 0$ and $\delta > 0$, it is known as the viscous Cahn-Hilliard equation. The authors construct a family of exponential attractors $\mathcal{E}_{\omega, \delta}$ for problem (11)-(13) which is a robust perturbation of an exponential attractor $\mathcal{E}_{0,0}$ of the usual Cahn-Hilliard equation. They show the existence of constants $C > 0$ and $\tau \in (0, 1)$ such that $\text{dist-sym}(\mathcal{E}_{\omega, \delta}, \mathcal{E}_{0,0}) \leq C(\omega + \delta)^\tau$ in a suitable functional space.

Example 7

See Example 4, in section 1.1

1.7 Dimensions in a metric space

1.7.1 Definitions

Let K be a compact set in a metric space E .

The Kolmogorov ϵ -entropy

For $\epsilon > 0$, $N_\epsilon(K, E)$ denotes the minimum number of open balls in E , with radius ϵ , necessary to cover K . The number

$$\mathbb{H}_\epsilon(K, E) = \ln(N_\epsilon(K, E))$$

is called the ϵ -entropy of K in E .

The fractal dimension of K in E is

$$\dim_F(K, E) = \limsup_{\epsilon \rightarrow 0} \frac{\mathbb{H}_\epsilon(K, E)}{\ln 1/\epsilon}.$$

The Hausdorff dimension of K in E

Given $d \in \mathbb{R}^+$ and $\epsilon > 0$ set

$$\mu(K, d, \epsilon) = \inf \sum r_i^d$$

where the infimum is taken over all the coverings $\{B_{r_i}(x_i)\}$ of K by balls in E with radius $r_i \leq \epsilon$. The Hausdorff dimension of H in E is the number

$$\dim_H(K, E) = \inf_{d \in \mathbb{R}^+} [\lim_{\epsilon \rightarrow 0} \mu(K, d, \epsilon)]$$

1.7.2 Remarks and examples

1.7.2.1 Remarks (cf. V.V. Chepyzhov, M.I. Vishik [23] p.52) In general, the following inequality holds:

$$\dim_H(K, E) \leq \dim_F(K, E)$$

If K is a smooth m -dimensional compact submanifold in E , then

$$\dim_H(K, E) = \dim_F(K, E) = m$$

Every countable set has Hausdorff dimension 0 while the fractal dimension can be arbitrarily large. For example, if $K = \{0\} \cup \{a_n = \frac{1}{\log n}\}_{n \in \mathbb{N}}$ then $\dim_F(K, \mathbb{R}) = 1$. If E is a Hilbert space, $\{e_n\}$ is an orthonormal basis in E , and $K = \{0\} \cup \{\frac{e_n}{\log n}\}_{n \geq 2}$, then $\dim_F(K, E) = \infty$.

1.7.2.2 Fractals (cf. K. Falconer [42] and [43])

A **self similar set** in \mathbb{R}^n is a set which is invariant under a collection of similarities. It is the union of a number of smaller similar copies of itself (cf. [42] p.117 and [43] p.35). The following examples are self similar sets whose fractal and Hausdorff dimensions are equal.

In \mathbb{R} the dimensions of the Cantor set ([95] and [42] p.43) are $\frac{\log 2}{\log 3}$.

In \mathbb{R}^2 , the Sierpinski triangle, Figure 2, also called the Sierpinski gasket, has dimensions $\frac{\log 3}{\log 2}$ ([42] p.120), whereas the Sierpinski carpet (Figure 3) has dimensions $\frac{\log 8}{\log 3}$ ([43] p.36). In Figures 2 and 3, pre-fractals E^4 (cf. section 1.1), for the Sierpinski triangle and carpet respectively, are the union of closed blue sets.

1.8 Dirac operator

The **One dimensional periodic Dirac operator** has the form:

$$Ly(x) = i \begin{bmatrix} 1 & 0 \\ 0 & -1 \end{bmatrix} \frac{dy}{dx} + \begin{bmatrix} 0 & P(x) \\ Q(x) & 0 \end{bmatrix} y, \quad x \in \mathbb{R}, \quad y = \begin{bmatrix} y_1 \\ y_2 \end{bmatrix}$$

where P and Q are periodic of period 1 and are in $L^2(0, 1)$.

In [34], P. Djakov, B. Mityagin suppose $Q(x) = \overline{P(x)}$. Then, L , considered with periodic or antiperiodic boundary conditions, is self-adjoint. If $\lambda_n^-, \lambda_n^+, n \in \mathbb{Z}$ are its eigenvalues close to $n\pi$ as $|n|$ is large, and $\gamma_n = \lambda_n^+ - \lambda_n^-$, the relationship between the decay rate of γ_n as $|n| \rightarrow \infty$, and the smoothness of P is investigated.

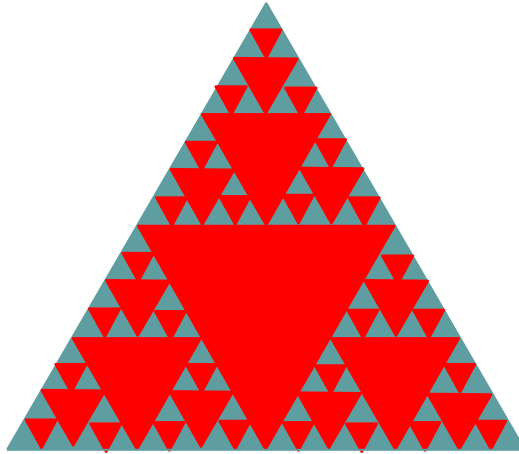

Figure 2. The Sierpinski gasket

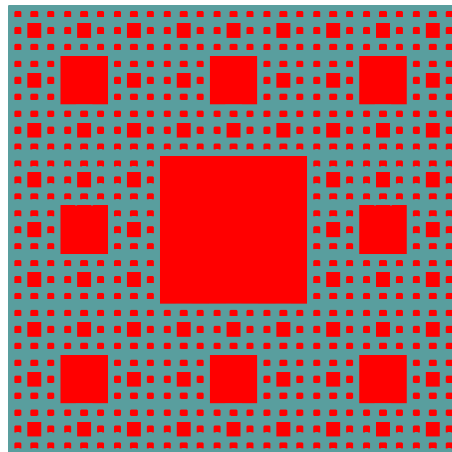

Figure 3. The Sierpinski carpet

1.9 Distances

1.9.1 Distances in a metric space

Let (E, d) be a metric space and $X, Y \subseteq E$.

The Hausdorff non-symmetric- (or semi-) distance between sets X, Y in E is

$$\text{dist}_E(X, Y) = \sup_{x \in X} \inf_{y \in Y} d(x, y)$$

The Hausdorff symmetric distance between sets X, Y in E is

$$\text{dist-sym}_E(X, Y) = \max(\text{dist}_E(X, Y), \text{dist}_E(Y, X)).$$

1.9.2 Quasi-distance, doubling quasi metric space

On a set Y , a function $d : Y \times Y \rightarrow [0, \infty)$ is called a **quasi distance** if it is symmetric, strictly positive away from $\{x = y\}$ and such that for some constant $K \geq 1$

$$d(x, y) \leq K(d(x, z) + d(z, y))$$

for all $x, y \in Y$. The pair (Y, d) is called a **quasi metric space**. A positive measure μ on a σ -algebra of subsets of Y containing the d -balls is said to have the **doubling property** if there exists a positive constant C such that

$$0 < \mu(B(x, 2r)) \leq C\mu(B(x, r))$$

for all $x \in Y$ and $r > 0$. Then (Y, d, μ) is called a **doubling quasi metric space** (cf. G. Di Fazio, C.E. Gutierrez, E. Lanconelli [33]).

1.10 Equal- area condition

Equal-area type conditions appear, as sufficient or necessary conditions, in the formation of layers (internal or superficial) in stationary solutions to various singularly perturbed reaction-diffusion systems. In the recent works A.S. do Nascimento [82], J. Crema, A.S. do Nascimento [28] and R.J. de Moura, A.S. do Nascimento [79], the authors prove the necessity of suitable equal-area condition for the formation of internal or (and) superficial transition layers in this type of problems.

Example 8

A simple particular case of problems studied in [82] is the elliptic boundary value problem

$$\begin{cases} \epsilon \text{div}(h(x)\nabla u) + f(u) = 0 & x \in \Omega \\ \frac{\partial u}{\partial n} = 0 & \text{on } \partial\Omega \end{cases} \quad (14)$$

where Ω is a smooth domain in \mathbb{R}^N , $N \geq 1$, $f : \mathbb{R} \rightarrow \mathbb{R}$ is such that there exist $\alpha, \beta, \alpha > \beta$, with $f(\alpha) = f(\beta) = 0$. Let $\Gamma \subset \Omega$ be a smooth (N-1) dimensional compact manifold without boundary. It is proved that, if (14) has a family $\{u_\epsilon\}$ of solutions which develop an **internal** transition layer with interface Γ connecting the states α to β , then, necessarily, the simple **equal-area condition**

$$\int_{\alpha}^{\beta} f(s) ds = 0$$

is satisfied.

Example 9

In [28], the following stationary system is considered:

$$\begin{cases} \epsilon \operatorname{div}(h(x)\nabla u) + f(x, u, \mathbf{v}) = 0 & x \in \Omega \\ \operatorname{div}(\mathbf{k}(x)\nabla \mathbf{v}) + \mathbf{g}(x, u, \mathbf{v}) = 0 & x \in \Omega \\ \frac{\partial \mathbf{v}}{\partial n} = 0 \text{ (or } \mathbf{v} = \mathbf{0}) & \text{on } \partial\Omega. \end{cases} \quad (15)$$

where Ω is a smooth domain in \mathbb{R}^N , $N \geq 1$, $\mathbf{v}, \mathbf{k}, \mathbf{g}$ are sufficiently smooth \mathbb{R}^n -valued functions, and $\mathbf{k}\nabla \mathbf{v} = (k_1 \nabla v_1, \dots, k_n \nabla v_n)$. Let \mathcal{U} be an open connected set in Ω , $\Gamma \subset \bar{\mathcal{U}}$ be an (N-1)-dimensional compact connected orientable manifold whose boundary $\partial\Gamma$ is such that $\partial\Gamma \cap \partial\Omega$ is an (N-2)-dimensional submanifold of $\partial\Omega$. A definition of a family of **internal** transition layer solutions $\{(u_\epsilon, \mathbf{v}_\epsilon)\}, 0 < \epsilon < \epsilon_o\}$ to (15) in \mathcal{U} with interface Γ , depending on two functions $\alpha, \beta \in C^o(\mathcal{U})$, $\alpha(x) < \beta(x)$ on Γ is given. For such a family, there exists u_o [resp. \mathbf{v}_o] such that $u_\epsilon \rightarrow u_o$ [resp. $\mathbf{v}_\epsilon \rightarrow \mathbf{v}_o$] on compact sets of $\bar{\mathcal{U}} \setminus \Gamma$ [resp. in $\bar{\mathcal{U}}$]. It is proved that, if a family of internal transition layer solutions to (15) exists, then $f(x, u_o(x), \mathbf{v}_o(x)) = 0$ on $\mathcal{U} \setminus \Gamma$ and necessarily the **equal-area condition**

$$\int_{\Gamma} \left(\int_{\alpha(x)}^{\beta(x)} f(x, s, \mathbf{v}_o(x)) ds \right) dS = 0$$

is satisfied. Several concrete applications of these results are presented in the paper.

Example 10

In [79], Ω is a bounded domain in \mathbb{R}^N , $N \geq 1$ with C^2 boundary $\partial\Omega$, S is a C^2 (N-1)-dimensional surface with a boundary Σ which is assumed to be a C^2 (N-2)-dimensional compact surface without boundary with $\Sigma = \bar{S} \cap \partial\Omega$, and \bar{S} intersects $\partial\Omega$ transversally. The authors define a family of solutions $\{u_\epsilon\}, 0 < \epsilon < \epsilon_o$ to the elliptic boundary value problem:

$$\begin{cases} \epsilon \operatorname{div}(a(x)\nabla v_\epsilon) + f(x, v_\epsilon) = 0, & x \in \Omega \\ \epsilon a(x) \frac{\partial v_\epsilon}{\partial \hat{n}} = g(x, v_\epsilon), & x \in \partial\Omega \end{cases} \quad (16)$$

which develops **internal and superficial** transition layers, depending on some smooth functions $\alpha, \beta, \alpha(x) < \beta(x), x \in \bar{\Omega}$, with interfaces S and Σ respectively. Here $a \in C^1(\bar{\Omega}), a > 0, f : \Omega \times \mathbb{R} \rightarrow \mathbb{R}$ and $g : \partial\Omega \times \mathbb{R} \rightarrow \mathbb{R}$ are of class C^1 and \hat{n} is the exterior normal vector field on $\partial\Omega$. It is proved that the **equal-area conditions**:

$$\int_{\alpha(x)}^{\beta(x)} f(x, t) dt = 0 \quad \forall x \in S \quad \text{and} \quad \int_{\alpha(y)}^{\beta(y)} g(y, t) dt = 0 \quad \forall y \in \Sigma$$

are necessary for the existence of such solutions.

1.11 Fokker-Planck equation

1.11.1 Forward Kolmogorov equation

Let $p(s, x, t, y)$ be a transition density of a Markov process, with a drift coefficient $\alpha(t, x)$ and a diffusion coefficient $\sigma^2(t, x)$. Under suitable assumptions on p, α, σ^2 , p is a fundamental solution of the **forward Kolmogorov equation**:

$$\frac{\partial p}{\partial t} = - \frac{\partial}{\partial y} (\alpha(t, y)p) + \frac{1}{2} \frac{\partial^2}{\partial y^2} (\sigma^2(t, y)p)$$

known as the **Fokker-Planck equation** (cf. Encyclopaedia of Mathematics, Springer Online reference Works, [39])

1.11.2 The Kuramoto model

In [66], Y. Kuramoto studies a large set of coupled oscillators Q_1, \dots, Q_N with natural frequencies w_i . He considers the simple possible case of purely sinusoidal coupling, for which the governing equations are

$$\frac{\partial \theta_i}{\partial t} = \omega_i + \frac{K}{N} \sum_{j=1}^N \sin(\theta_j - \theta_i), \quad i = 1, \dots, N \quad (17)$$

where $K \geq 0$ is the coupling strength. The example of a Lorentzian distribution of the native frequency is studied. Setting

$$r e^{i\psi} = \frac{1}{N} \sum_{j=1}^N e^{i\theta_j} \quad (18)$$

called the complex parameter, where $r(t)$ measures the phase coherence and $\psi(t)$ the average phase, (17) becomes

$$\frac{\partial \theta_j}{\partial t} = \omega_j + Kr \sin(\psi - \theta_j) \quad j = 1, \dots, N \quad (19)$$

(cf. Y. Kuramoto [67])

1.11.3 From Kuramoto to Crawford

In [94], S. H. Strogatz tells the story of coupled oscillators, from Y. Kuramoto's work to J.D. Crawford's contributions.

1.11.3.1 The infinite-N version of (17) The frequencies ω are distributed according to the probability density $g(\omega)$. Let $\rho(\theta, t, \omega)$ denote the fraction of oscillators with natural frequency ω and phase in $[\theta, \theta + d\theta]$, at time t . Then, ρ is non-negative, 2π - periodic in θ , and satisfies the normalization condition $\int_0^{2\pi} \rho(\theta, t, \omega) d\theta = 1$, for all t, ω . The evolution of ρ is governed by the continuity condition

$$\frac{\partial \rho}{\partial t} = -\frac{\partial}{\partial \theta}(\rho v) \quad (20)$$

which expresses the conservation of oscillators with frequency ω . The infinite-N version of (18) and (19) are respectively

$$r e^{i\psi} = \int_0^{2\pi} \int_{-\infty}^{+\infty} e^{i\theta} \rho(\theta, t, \omega) g(\omega) d\omega d\theta \quad (21)$$

and

$$v(\theta, t, \omega) = \omega + K \int_0^{2\pi} \int_{-\infty}^{+\infty} \sin(\theta' - \theta) \rho(\theta', t, \omega') g(\omega') d\theta' d\omega' \quad (22)$$

Finally, the governing equation for ρ becomes

$$\frac{\partial \rho}{\partial t} = -\frac{\partial}{\partial \theta} \left(\rho \left[\omega + K \int_0^{2\pi} \int_{-\infty}^{+\infty} \sin(\theta' - \theta) \rho(\theta', t, \omega') g(\omega') d\theta' d\omega' \right] \right) \quad (23)$$

1.11.3.2 Introduction of noise processes In [85], H. Sakaguchi considers the Fokker-Planck equation

$$\frac{\partial \rho}{\partial t} = D \frac{\partial^2 \rho}{\partial \theta^2} - \frac{\partial}{\partial \theta}(\rho v) \quad (24)$$

where $D \geq 0$ is a noise strength. Equation (24) reduces to (23) for $D = 0$.

1.11.3.3 Crawford's work J.D. Crawford worked on Kuramoto-Sakaguchi's model (24) (cf. [27]). Later on, he considered a more general model where $\sin(\theta' - \theta)$ is replaced by $f(\theta' - \theta)$

1.11.4 The Acebron-Spigler model

In [1], J.A. Acebron, R. Spigler, are interested in self-synchronization among the coupled oscillators, both in phase and in frequency. They point out that the Kuramoto-Sakaguchi model with noise terms does not allow for simultaneous synchronization in both phase and frequency. They propose a new model in which frequencies of the oscillators vary in time along with their phase. The governing equations, when $N \gg 1$ and noise effects are included, are a set of Langevin equations, which lead, when $N \rightarrow \infty$, to a Fokker-Planck type equation of the form (with normalized parameters)

$$\frac{\partial \rho}{\partial t} = \frac{\partial^2 \rho}{\partial \omega^2} - \omega \frac{\partial \rho}{\partial \theta} + \frac{\partial}{\partial \omega} [(\omega - \Omega - K\mathcal{K}(t, \theta))\rho] \quad (25)$$

where

$$\mathcal{K}(t, \theta) = \int_{-\infty}^{+\infty} \int_{-\infty}^{+\infty} \int_0^{2\pi} g(\Omega) \sin(\varphi - \theta) \rho(\varphi, \omega, t, \Omega) d\varphi d\omega d\Omega$$

associated with the conditions $\rho|_{\theta=0} = \rho|_{\theta=2\pi}$, $\rho|_{t=0} = \rho_o(\theta, \omega, \Omega)$, $\rho(\theta, \omega, t, \Omega) > 0$ and $\int_0^{2\pi} \int_{-\infty}^{+\infty} \rho(\theta, \omega, t, \Omega) d\omega d\theta = 1$ for all t, Ω . Here $\theta(t)$ is the phase and $\omega(t) = \frac{d\theta}{dt}(t)$ the frequency, at time t , and $g(\Omega)$ represents a natural frequency distribution.

1.11.6 The Fokker-Planck type ultraparabolic integro-differential equation

In [3] and [4], D.R. Akhmetov, M.M. Lavrentiev JR. and R. Spigler study existence and uniqueness of solutions to (25), in $\mathcal{Q}_T = \{(\theta, \omega, t, \Omega) \in [0, 2\pi] \times \mathbb{R} \times [0, T] \times [-G, +G]\}$, when $g \in L^1(\mathbb{R})$ is bounded and compactly supported in $[-G, +G]$ and the initial condition ρ_o has an exponential decay in ω at infinity, namely

$$\sup_{\theta \in \mathbb{R}, \Omega \in [-G, +G]} |D_{\theta, \omega, \Omega}^{l_1, l_2, l_3} \rho_o(\theta, \omega, \Omega)| \leq C e^{-M\omega^2}$$

for all $\omega \in \mathbb{R}$, $l_1 + l_2 + l_3 \leq l_o$. Equation (25) may be interpreted as an ultraparabolic (integro-differential) equation with $t_1 = \theta$, $t_2 = t$ or as a parabolic equation in (ω, θ) , degenerate with respect to θ (cf. section 2.18). In [3] and [4] existence and uniqueness of a solution ρ to problem (25), either in anisotropic Sobolev and Hölder spaces or in suitable classes of decaying functions, are considered. Optimal decay estimates for ρ were obtained in D.R. Akhmetov, R. Spigler [6]. The proofs are based on suitable parabolic regularization of (25).

Conclusion In this entry, I was mostly interested in the successive forms of the Fokker-Planck type equation, from the Kuramoto model to the recently studied ultraparabolic equations. The analysis of these equations and their innumerable applications will be found in the references .

1.12 Gierer-Meinhardt system

1-The Gierer-Meinhardt model

The Gierer-Meinhardt model is a system of two coupled nonlinear parabolic equations:

$$A_t = d\Delta A - A + \frac{A^2}{H}, \quad H_t = D\Delta H - H + A^2, \quad x \in \Omega, t > 0$$

associated with the boundary conditions

$$\frac{\partial A}{\partial n} = \frac{\partial H}{\partial n} = 0, \quad x \in \partial\Omega, t \geq 0,$$

where Ω is a bounded Lipschitzian domain, in \mathbb{R} or \mathbb{R}^2 , $A = A(x, t)$ and $H = H(x, t)$ are the concentrations of an activator substance and an inhibitor substance, respectively, in cell biology and physiology, (cf. Y. You [102]).

Example 11

In [102], the author considers the ground state solutions of the Gierer-Meinhardt-type system in \mathbb{R} i.e. the solutions of the system of ordinary differential equations:

$$u'' - u + \frac{u^2}{v} = 0, \quad v'' - \sigma^2 v + u^2 = 0, \quad x \in \mathbb{R} \quad (26)$$

associated with the conditions $u, v > 0$ and $u, v \rightarrow 0$ as $|x| \rightarrow \infty$, where $\sigma^2 = \frac{d}{D} \ll 1$. The author is interested in an approximation of the number $k(\sigma)$ of spikes of the solutions to (26) one can expect to occur, as $\sigma \rightarrow 0$. He shows that, for σ small enough, there exists a solution (u, v) of (26) such that u has $k = \text{const } \sigma^{-\beta}$ spikes where β can be arbitrarily close to $\frac{1}{2}$.

1.13 Gray-Scott systems

The Gray-Scott model

This reaction-diffusion system models an irreversible reaction involving two reactants in a gel reactor, where the reactor is maintained in contact with a reservoir of one of the two chemicals in the reaction. In dimensionless units it can be written as

$$\begin{cases} V_t = b\Delta V - (F + k)V + UV^2, & \text{in } \Omega \\ U_t = a\Delta U + F(1 - U) - UV^2, & \text{in } \Omega \\ \frac{\partial U}{\partial \nu} = \frac{\partial V}{\partial \nu} = 0, & \text{on } \partial\Omega \end{cases},$$

where the unknowns $U(x, t)$ and $V(x, t)$ represent the concentrations of the two biochemicals at a point $x \in \Omega \subset \mathbb{R}^N$, $N \leq 3$ at the time t ; Ω is a bounded smooth domain, a, b are the diffusion coefficients of U and V respectively, F denotes the rate at which U is fed from the reservoir into the reactor, and k is a reaction-time constant. Various Gray-Scott problems have been intensively studied in the recent years, with different values of the parameters N, a, b, F, k and different choices for Ω , (cf. T. Kolokolnikov, J. Wei [65])

Example 12

In [35] and [36], A. Doelman, R.A. Gardner, T.J. Kaper consider the following system :

$$\begin{aligned} \frac{\partial u}{\partial t} &= \frac{\partial^2 u}{\partial x^2} - uv^2 + \delta^2 a(1 - u) \\ \frac{\partial v}{\partial t} &= \delta^2 \frac{\partial^2 v}{\partial x^2} + uv^2 - \delta^\beta bv, \end{aligned}$$

where $x \in \mathbb{R}$, $a, b = \mathcal{O}(1)$ with respect to δ and $0 \leq \beta < 1$

Example 13

In [76], D.S. Morgan and T.J. Kaper study, in R^2 , stationary ring solutions, for $r \in [0, r_{max}]$, of the system

$$\begin{aligned} \frac{\partial^2 U}{\partial r^2} + \frac{1}{r} \frac{\partial U}{\partial r} &= UV^2 - A + AU \\ D \left(\frac{\partial^2 V}{\partial r^2} + \frac{1}{r} \frac{\partial V}{\partial r} \right) &= -UV^2 + BV, \end{aligned}$$

with boundary conditions $U_r(0) = U_{r_{max}}(0) = V_r(0) = V_{r_{max}}(0) = 0$ where A, B, D , are constants with $D \ll 1$.

Example 14 In [65], the following Gray-Scott systems and the associated stationary system in a bounded smooth domain $\Omega \subset \mathbb{R}^N$ are considered

$$\begin{aligned} \frac{\partial v}{\partial t} &= \epsilon^2 \Delta v - v + Auv^2 \\ \tau \frac{\partial u}{\partial t} &= \Delta u - (6\epsilon)^{-1} uv^2 + (1 - u), \\ u > 0, v > 0 \end{aligned}$$

associated with the boundary condition $\frac{\partial u}{\partial \nu} = \frac{\partial v}{\partial \nu} = 0$ on $\partial\Omega$, mostly when $N=2, 3$ and Ω is a ball B_R of center 0 and radius R ; the cases $\Omega = \mathbb{R}^N$, or $\mathbb{R}^N \setminus B_R$, or $B_{R_2} \setminus B_{R_1}$ are also discussed.

1.14 Hyperbolic secant

Definition 5.

$$sech\left(\frac{t}{2}\right) = \frac{2e^{\frac{t}{2}}}{e^t + 1}$$

(cf. Z.X. Wang, D.R. Guo [99])

Application

The fisher function

$$w(y) = \frac{3}{2} \operatorname{sech}^2\left(\frac{y}{2}\right)$$

is a solution to the problem:

$$w'' - w + w^2 = 0, \quad w(0) = \operatorname{Max}_{y \in \mathbb{R}} w(y) \text{ and } w(y) \rightarrow 0 \text{ as } |y| \rightarrow \infty.$$

which appears in the resolution of Gray-Scott problems (see section 1.13, [65] p.204 and W. Chen, M.J. Ward [21] p.191)

2 From Kirchoff-type equations to Wavefront sets

2.1 Kirchoff-type equations

2.1.1 The Kirchoff model

In [63], G. Kirchoff studies the integro-differential equation:

$$u_{tt} - \left(\epsilon^2 + \frac{1}{2\ell} \int_0^\ell u_s^2 ds \right) \cdot u_{ss} = 0 \quad (27)$$

which appears in transversal vibrations of an elastic string of length ℓ . This Kirchoff model is briefly described in S. Spagnolo [91]. Since then, Kirchoff-type equations have been intensively studied in different situations.

2.1.2 The Cauchy problem for a Kirchoff-type equation

. Let Ω be an open subset of \mathbb{R}^n . We note that equation (27) is a particular case of

$$u_{tt} - \varphi \left(\int_\Omega |\nabla u|^2 dx \right) \Delta u = 0 \quad (28)$$

where φ is a regular function satisfying $\varphi(s) \geq \lambda_o > 0, \forall s > 0$, (In (27) $\varphi(s) = \epsilon^2 + \frac{1}{2\ell}s$). More generally, in [91] a Kirchoff-type equation is defined as:

$$u_{tt} - \sum_{i,j=1}^n \varphi_{ij} \left(\|D^{\beta_1} u\|_{L^2(\Omega)}, \dots, \|D^{\beta_p} u\|_{L^2(\Omega)} \right) u_{x_i x_j} = 0 \quad (29)$$

where the $\varphi_{ij}(s_1, \dots, s_p)$ are regular functions satisfying

$$\sum_{i,j=1}^n \varphi_{ij}(s_1, \dots, s_p) \xi_i \xi_j \geq \lambda_o |\xi|^2, \quad \lambda_o \geq 0 \quad (30)$$

and $\beta_j \in \mathbb{N}^n$. Being inspired by S. Bernstein's paper [16], the author investigates, in suitable functional spaces, local in t and global existence, uniqueness of solutions u to equation (29) associated with initial conditions $u(0, x) = u_o(x), u_t(0, x) = u_1(x), x \in \Omega$, when Ω is an interval of \mathbb{R} and $u(t, \cdot)$ is Ω -periodic, or $\Omega = \mathbb{R}^n$.

2.1.3 Pseudo-differential operators of Kirchhoff-type

In [30], P. D'Ancona and S. Spagnolo show the existence of a unique solution, in a suitable functional space, to the pseudo-differential equation

$$u_{tt} + F(\|a_1(-iD_x)u\|_{L^2}^2, \dots, \|a_p(-iD_x)u\|_{L^2}^2; -iD_x) u = 0 \quad (31)$$

associated with initial conditions of the form

$$u(0, x) = \epsilon u_o(x), \quad u_t(0, x) = \epsilon u_1(x) \quad (32)$$

where $a_j(\xi)$ are smooth functions on $\mathbb{R}^n \setminus 0$ satisfying growth conditions, $F(s_1, \dots, s_p; \xi_1, \dots, \xi_n)$ is a C^2 real function defined on $\mathbb{R}^p \times \mathbb{R}^n$, with $|s| \leq 1, |\xi| \neq 0$, and satisfying for some real numbers $\nu > 0, m \geq 1$:

$$F(s; \lambda \xi) = \lambda^{2m} F(s, \xi) \quad \forall \lambda \geq 0,$$

$$\nu^2 |\xi|^{2m} \leq F(s, \xi) \leq \nu^{-2} |\xi|^{2m}, \quad |\nabla_\xi F(s, \xi)| \leq \nu^{-1} |\xi|^{2m-1}$$

and ϵ small enough. A particular case of (31) is the equation:

$$u_{tt} + (-1)^m \sum_{|\alpha|=2m} f_\alpha(\|D_x^{\beta_1} u\|_{L^2}^2, \dots, \|D_x^{\beta_p} u\|_{L^2}^2) D_x^\alpha u = 0 \quad (33)$$

where $f_\alpha(s_1, \dots, s_p)$ are C^2 real functions on \mathbb{R}^p , satisfying the strict hyperbolicity condition

$$\sum_{|\alpha|=2m} f_\alpha(s_1, \dots, s_p) \xi^\alpha \geq \nu^2 |\xi|^{2m}, \quad \nu > 0 \quad (34)$$

The simplest example of equation (33) is equation (28), where $\Omega = \mathbb{R}^n$.

2.1.4 Abstract setting of Kirchhoff-type equation

. Let H be a Hilbert space, A a selfadjoint non-negative operator on H , with dense domain $D(A)$. Then there exists a unique self-adjoint positive operator $A^{\frac{1}{2}}$ such that $(A^{\frac{1}{2}})^2 = A$. (For the definition and properties of A^α , $0 < \alpha < 1$, see, for instance, D. Huet [57], T. Kato [61] or M. Schechter [86]). If $H = L^2(\Omega)$, $A = -\Delta$, $D(A) = H^2(\Omega) \cap H_0^1(\Omega)$, the equation

$$u_{tt} + \varphi(|A^{\frac{1}{2}}u|^2)Au = O \quad (35)$$

becomes equation (28) ($\|\cdot\|$ denotes the norm in H). The abstract Cauchy problem

$$u''(t) + \delta u'(t) + m(|A^{\frac{1}{2}}u(t)|^2)Au(t) = 0, \quad t \geq 0, \quad u(0) = u_o, \quad u'(0) = u_1 \quad (36)$$

is investigated in M. Ghisi, M. Gobino [49], where $\delta > 0$ and $m : [0, +\infty[\rightarrow [0, +\infty[$ is a locally Lipschitz continuous function. When $(u_o, u_1) \in D(A) \times D(A^{\frac{1}{2}})$ and under the nondegeneracy condition $m(|A^{\frac{1}{2}}u_o|^2) > 0$, existence, uniqueness, in suitable functional spaces, of u solution to (36), and the asymptotic behavior of $(u(t), u'(t), u''(t))$, in $D(A) \times D(A^{\frac{1}{2}}) \times H$, as $t \rightarrow \infty$, are studied.

2.1.5 Singular perturbations in Kirchhoff type equations.

In M. Ghisi, M. Gobino [50], time-decay estimates, as $t \rightarrow \infty$, are obtained for the singularly perturbed Cauchy problem

$$\epsilon u_\epsilon'' + u_\epsilon' + m(|A^{\frac{1}{2}}u_\epsilon|^2)Au_\epsilon = 0, \quad u_\epsilon(0) = u_o, \quad u_\epsilon'(0) = u_1 \quad (37)$$

and for the first order limit problem

$$u' + m(|A^{\frac{1}{2}}u|^2)Au = O, \quad u(0) = u_o \quad (38)$$

where $\epsilon > 0$, $(u_o, u_1) \in D(A) \times D(A^{\frac{1}{2}})$ and m is of class C^1 . Decay estimates are stated for equation (38) under the nondegeneracy condition $|A^{\frac{1}{2}}u_o|^2 m(|A^{\frac{1}{2}}u_o|^2) > 0$, and, for equation (37), under a weaker condition $m(|A^{\frac{1}{2}}u_o|^2) > 0$. In this last case, most of the constants which appear in decay estimates are independent of ϵ . A clear comparison with similar previous estimates, obtained by several authors, is presented

2.2 Lyusternik-Schnirelman category

This category is defined in L.A. Lyusternik, L. Schnirelman [71], (see also Encyclopaedia of Mathematics [38]). It arises in T. Bartsch, T. Weth [13], where the number of nodal solutions to a nonlinear elliptic Dirichlet problem can be expressed as the category of a suitable inclusion between two spaces which involve the shape of $\partial\Omega$ (cf. section 2.8 example 20).

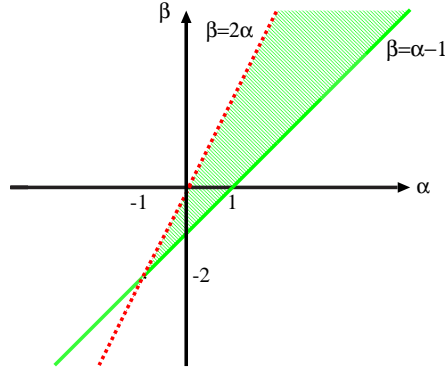

Figure 4. The $\alpha - \beta$ plane

2.3 Mathieu-Hill type equations

2.3.1 Mathieu and Hill Equations

The real Mathieu [resp. Hill] equation has the form

$$y'' + (a + b \cos 2\pi x)y = 0$$

where a and b are constants, [resp.

$$y'' + (a + bq(x))y = 0]$$

where q is any smooth periodic function of period 1 with mean 0 (see E.A. Coddington, N. Levinson [24] and Z.X. Wang, D.R. Guo [99]). Physical problems leading to Mathieu or Hill equations often require solutions with periodicity, called oscillatory solutions. Therefore, to find conditions on the data for which the above equations have a fundamental system of periodic solutions is a central problem.

2.3.2 Its Equation

In [59], A.R. Its considers the Schrödinger equation on the positive semi-axis

$$y'' - [x^\beta p(x^{1+\alpha}) + cx^{-2}]y = 0 \quad (39)$$

where p is a smooth periodic function, with period 1 and mean 0, c is a real number and the parameters α, β satisfy the relations $\beta - \alpha \geq -1$ and $2\alpha - \beta > 0$ (cf. Figure 4.). He proves that equation (39) has oscillatory solutions when $\beta > \alpha - 1$. If $\beta = \alpha - 1$, the solutions are oscillatory or not. In all cases,

asymptotic formulas for the solutions are stated, as $x \rightarrow \infty$. His method is based on a transformation which leads to a Hill-type equation and Floquet functions.

2.3.3 Method of diagonalisation

In [17], S. Bodine and D.A. Lutz investigate equation (39) by a general method of diagonalization with a L^1 -regularity for p. Set

$$t = x^{1+\alpha}, \quad \rho(t) = \int_0^t \frac{p(s)}{1+\alpha} ds, \quad \mu = \int_0^1 \rho(t) dt, \quad \nu = \int_0^1 (\rho(t))^2 dt, \quad (\mu^2 < \nu).$$

Let

$$\lambda_{1,2} = \left(\frac{1}{2} \pm \sqrt{c + \mu^2 - \nu + \frac{1}{4}}\right) / (1 + \alpha)$$

be the eigenvalues of a suitable matrix which depends on α, c, μ, ν , and Λ be the crucial diagonal matrix $diag\{\lambda_1, \lambda_2\}$. When $\beta = \alpha - 1$, three cases are studied separately according to $\lambda_1 - \lambda_2$ belongs to \mathbb{N} , does not belong to \mathbb{N}_0 or is equal to 0. In each case, very sharp asymptotic formulas are obtained for a fundamental system of solutions to (39). In particular, when $\lambda_1 - \lambda_2 \in \mathbb{N}_0$, a logarithmic term appears in the formulas. For instance, when $\lambda_1 - \lambda_2 \in \mathbb{N}$ the following formulas are obtained:

$$y_1(x) = x^{\lambda_1(1+\alpha)} \left[1 + \sum_{r=1}^{N-1} \frac{p_r^1(x^{1+\alpha})}{x^{r(1+\alpha)}} + \mathcal{O}\left(\frac{1}{x^{N(1+\alpha)}}\right) \right] + \eta(\ln x) y_2(x)$$

$$y_2(x) = x^{\lambda_2(1+\alpha)} \left[1 + \sum_{r=1}^{N-1} \frac{p_r^2(x^{1+\alpha})}{x^{r(1+\alpha)}} + \mathcal{O}\left(\frac{1}{x^{N(1+\alpha)}}\right) \right]$$

where $p_r^{1,2}$ are scalar valued, bounded, continuous, periodic functions with period 1 which are recursively calculated. This logarithmic term is missing in its formulas.

2.4 Memory (equations with)

In [25], M. Conti, V. Pata and M. Squassina consider the family of equations:

$$u_t - \omega \Delta u - (1 - \omega) \int_0^\infty k_\epsilon(s) \Delta u(t-s) ds + \varphi(u) = f, \quad t > 0$$

where $u : (x, t) \in \Omega \times \mathbb{R} \rightarrow \mathbb{R}$, the memory kernel $k : [0, \infty) \rightarrow \mathbb{R}$ is a continuous nonnegative function, satisfying the relation $\int_0^\infty k(s) ds = 1$ and $k_\epsilon(s) = \frac{1}{\epsilon} k\left(\frac{s}{\epsilon}\right)$; Ω is a smooth bounded domain in \mathbb{R}^3 , $\omega \in [0, 1)$, φ is a suitable nonlinearity, and f is a time independent source term, $u(x, t)$ is supposed to be a given datum for $t \leq 0$.

2.5 Moser-Trudinger inequality

2.5.1 The Moser-Trudinger inequality

The Moser-Trudinger inequality states that:

$$C(\Omega) = \sup_{u \in H_0^1(\Omega); \|\nabla u\|_2=1} \int_{\Omega} e^{4\pi u^2} dx < \infty$$

where Ω is a smooth bounded domain in \mathbb{R}^2 (see N.S. Trudinger [98] and J. Moser [78]).

2.5.2 A sharp form of the Moser-Trudinger inequality

Let $\lambda_1(\Omega) > 0$ be the first eigenvalue of the Laplacian with Dirichlet boundary conditions in Ω , and

$$C_{\alpha}(\Omega) = \sup_{u \in H_0^1(\Omega), \|\nabla u\|_2=1} \int_{\Omega} e^{4\pi u^2(1+\alpha\|u\|_2^2)} dx \quad (40)$$

In [2], Adimurthi and O. Druet proved that

$$C_{\alpha}(\Omega) < +\infty \text{ if } 0 \leq \alpha < \lambda_1(\Omega)$$

and

$$C_{\alpha}(\Omega) = +\infty \text{ if } \alpha \geq \lambda_1(\Omega)$$

In [101], Y. Yang, shows the existence of an extremal function for which the supremum, in (40), is attained in the case $0 \leq \alpha < \lambda_1(\Omega)$.

2.6 Moving planes and sliding methods

2.6.1 The classical method

The classical method of moving planes is described in J. Serrin [89], and used to prove the following result: if Ω is a bounded open connected domain in \mathbb{R}^n , whose boundary is of class C^2 , and if there exists $u \in C(\bar{\Omega})$ satisfying $\Delta u = -1$ in Ω , $u = 0$ and $\frac{\partial u}{\partial n} = \text{constant}$ on $\partial\Omega$, then Ω is a ball.

Example 15

In [15], H. Berestycki and L. Nirenberg used the moving plane and sliding methods in proving monotonicity or symmetry in the x_1 direction for solutions to nonlinear elliptic equations $F(x, u, Du, D^2u) = 0$ in a bounded domain $\Omega \subset \mathbb{R}^n$, which is convex in the x_1 direction. “Both methods compare values of the solution of the equation at two different points. In the moving plane method, one point is the reflection of the other in a hyperplane $x_1 = \lambda$ and

then, the plane is moved up to a critical position. In the sliding method, the second point is obtained from the first by sliding the domain in the x_1 direction and the domain is slid up to a critical position ". Many forms of the maximum principle are crucial in this paper.

2.6.2 Technique of the domain reflection

A different form of the classical moving plane analysis is used in E.M. Harrell, P. Kröger, K. Kurata [55]. Let Ω be a bounded open domain in \mathbb{R}^n , and P a hyperplane of dimension $n - 1$ which intersects Ω . For any connected set S which does not intersect P , S^P denotes its reflection through P . If there exists a connected component Ω_s of $\Omega \setminus P$ such that Ω_s^P is a proper subset of the other connected component Ω_b of $\Omega \setminus P$, P is called a **hyperplane of interior reflection** for Ω . Moreover Ω_s [resp. Ω_b] is called the small [resp. big] side of Ω , and Ω is said to have the **interior reflection property with respect to P** .

Example 16

Using the technique of the domain reflection, the authors study how to place, inside Ω , an obstacle or a well in order to minimize or maximize the principal eigenvalue of the Laplacian operator in Ω with zero Dirichlet boundary condition on the boundary $\partial\Omega$. The obstacle B may be hard (i.e. zero Dirichlet conditions are additionally imposed on B) or replaced by a central non-negative [resp. non-positive] function supported by B , i.e. the investigated operator has the form

$$-\Delta + \alpha\chi_B(x)$$

where χ_B is the indicator function of B , and $\alpha > 0$ [resp. < 0]. Several examples with very clear figures are presented. Similar problems are studied for the stationary Schrödinger operator in Ω .

Example 17

A similar problem is investigated, with the same technique of domain reflection, in P. Exner, A. Mantile [41]. Here B is replaced by a single point interaction $x_o \in \Omega$. The domain Ω is an open set in \mathbb{R}^d , $d = 2, 3$, bounded and connected, with a piecewise C^1 boundary. Let $\alpha \in \mathbb{R}, \lambda \in \mathbb{C} \setminus \mathbb{R}$. The authors consider a family of operators H_α , whose domain is

$$D(H_\alpha) = \{\psi \in L^2(\Omega), \psi = \Phi^\lambda + q\mathcal{G}_o^\lambda(\cdot, x_o), \phi^\lambda \in H^2 \cap H_o^1(\Omega)\}$$

and defined by

$$H_\alpha\psi = -\Delta\phi^\lambda - \lambda q\mathcal{G}_o^\lambda(\cdot, x_o),$$

associated with a suitable condition for $\Phi^\lambda(x_o)$, where \mathcal{G}_o^λ denotes the green function of $-\Delta + \lambda$ in Ω , corresponding with homogeneous Dirichlet boundary conditions on $\partial\Omega$. How to place the point interaction center x_o to minimize the principal eigenvalue of H_α is discussed.

2.7 N-mode solution

In [81], K. Nakashima, M. Urano and Y. Yamada, consider the following ordinary differential problem :

$$\epsilon^2 u''(x) + f(x, u(x)) = 0 \quad x \in]0, 1[; \quad u'(0) = u'(1) = 0 \quad (41)$$

where $f(x, u) = u(1-u)(u-a(x))$; a is a $C^2[0, 1]$ function such that $0 < a(x) < 1$, $a'(0) = a'(1) = 0$, and the subsets Σ and Λ of $(0, 1)$ where $a(x) = \frac{1}{2}$ and $a'(x) = 0$, respectively, are finite sets and $a'(x) \neq 0$ for any $x \in \Sigma$. The authors study the asymptotic behavior, as $\epsilon \rightarrow 0$, of n-mode solutions u_ϵ of (41) i.e. solutions such that $v_\epsilon = u_\epsilon - a$ has exactly n zero-points in $(0, 1)$, and show that any transition layer [resp. spike] is located in a neighborhood of a point of Σ [resp. Λ].

2.8 Nodal

2.8.1 Nodal points, curves, surfaces.

Definition 6. In R. Courant, D. Hilbert [26], they are defined as points [resp. curves, surfaces], on which some eigenfunctions of a differential problem, in a domain $G \in \mathbb{R}^N$, $N = 1$ [resp. $N = 2, 3$], vanishes.

Example 18

In the 1970 edition of [26], p.452, a second order Sturm-Liouville problem is considered. It is proved that the nodes of the n^{th} eigenfunction u_n divide the domain into no more than n subdomains.

2.8.2 Nodal solutions, nodal domains

Example 19

In [56], M. and T. Hoffman-Ostenhof and N. Nadirashvili study the Dirichlet eigenvalue problem

$$-\Delta u_i = \lambda_i u_i, \quad i = 1, 2, \dots \quad u \in H_o^1(D),$$

where D is a bounded domain in \mathbb{R}^n , . The nodal set of u_i is defined as

$$\mathcal{N}(u_i) = \overline{\{x \in D : u_i = 0\}}$$

The nodal domains of u_i are the connected components of $D \setminus \mathcal{N}(u_i)$. The authors construct a domain $D \subset \mathbb{R}^2$ on which the second eigenvalue has a nodal set disjoint from the boundary, whereas the nodal line conjecture, first mentioned by L.E. Payne [83], stated that

$$\mathcal{N}(u_2) \cap \partial D \neq \emptyset.$$

Example 20

In [13], T. Bartsch and T. Weth consider the nonlinear elliptic Dirichlet problem:

$$-\epsilon^2 \Delta u + au = f(u) \text{ in } \Omega, \quad u \in H_o^1(\Omega) \quad (42)$$

where Ω is a bounded domain in \mathbb{R}^N , $N \geq 2$, $a > 0$, ϵ is a small positive parameter, and f grows superlinearly and subcritically. They study the number of nodal solutions i.e. sign-changing solutions of (42) and their nodal domains (cf. section 2.2).

2.9 Nonlocal eigenvalue problem

This type of problem arises in the study of the stability of solutions of Gray-Scott problems under small perturbations of the form $e^{\lambda t}(U(x, t), V(x, t))$. It appears in the following form:

$$y'' + f(t)y = Cg(t) \int_{-\infty}^{+\infty} h(t)y(t)dt \quad (43)$$

where f, g, h , are known functions. It is called nonlocal because of the presence, in the right member of (43), of the nonlocal term $\int_{-\infty}^{+\infty} h(t)y(t)dt$.

Example 21

In [35],

$$f(t) = \left(\frac{12}{\cosh^2 t} - P\right), \quad g(t) = \frac{1}{\cosh^4 t}, \quad h(t) = \frac{1}{\cosh^2 t}$$

Example 22

In [76],

$$f(t) = (12 \sinh^2 t - P), \quad g(t) = \operatorname{sech}^4 t, \quad h(t) = \operatorname{sech}^2 t.$$

(see section 1.13).

2.10 Quasi-periodic Schrödinger operator

In their papers [45] and [46], A. Fedotov and F. Klop study the spectrum of quasi periodic schrödinger operators of the form

$$H_{z,\epsilon} = -\frac{d^2}{dx^2} + V(x - z) + \alpha \cos(\epsilon x) \quad (44)$$

where, $\alpha > 0$, $V \in L_{loc}^2(\mathbb{R})$ is periodic with period 1, z is a real parameter indexing the equations of the family; $\epsilon > 0$ is such that $\frac{2\pi}{\epsilon}$ is irrational. Let

$$H_o = -\frac{d^2}{dx^2} + V(x)$$

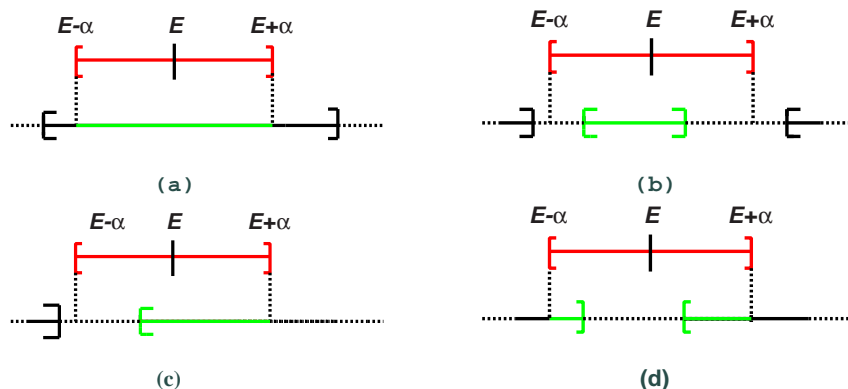

Figure 5. Spectral band

be the periodic Schrödinger unperturbed operator. Its spectrum, on $L^2(\mathbb{R})$, consists of the union of intervals $[E_{2n-1}, E_{2n}]$, $n \geq 1$, such that $E_n \rightarrow \infty$, as $n \rightarrow \infty$. It is assumed that all the spectral gaps (E_{2n}, E_{2n+1}) are open. The spectrum of (44), at an energy E , depends on the relative position of the spectral window $\mathcal{F}(E) = [E - \alpha, E + \alpha]$ with respect to the spectrum of H_o . In [45] four cases are distinguished according as $\mathcal{F}(E)$ lies inside or completely covers a spectral band of H_o (Figure 5 (a) and Figure 5 (b) respectively) or contains exactly one edge (Figure 5 (c)) or two edges (Figure 5 (d)) of a spectral band. In each case, under specific additional assumptions, the authors describe the nature of the spectrum of (44), and state asymptotic formulas, as $\epsilon \rightarrow 0$. In [46], they are interested in the spectrum of (44), in intervals J such that for all $E \in J$, $\mathcal{F}(E)$ covers the edges of two neighboring spectral bands of H_o and the spectral gap located between them (Figure 5 (d)). Let Γ_R be the real iso-energy curve associated to (44) and γ_0, γ_π , be the connected components of Γ_R in a periodicity cell. To each of these loops, one associates a sequence of energies in J , E_a^n , $a = \{0, \pi\}$, and, near each E_a^n , an exponentially small interval I_a^n such that the spectrum of (44), in J , is contained in the union of these intervals. The location and the nature of the spectrum of (44) are investigated in the union $I_0^n \cup I_\pi^m$, in the resonant case, i.e. when I_0^n and I_π^m intersect each other.

2.11 Resonances

2.11.1 Resonances for a semi-classical Schrödinger operator.

In [11], H. Baklouti and M. Mnif consider the Schrödinger operator

$$P = h^2 D^2 + V, \quad D = -i \frac{d}{dx}$$

where the potential V satisfies the following assumptions: there exist $0 < \theta_0 < \frac{\pi}{2}$, $\delta > 0$, $C > 0$, $\alpha > 0$ such that V is real on \mathbb{R} , analytic on $S = \{x \in \mathbb{C}; \{|\operatorname{Im}(x)| < |\operatorname{Re}(x)| \tan(\theta_0)\} \cup \{|\operatorname{Im}(x)| < \delta\}\}$, $|V(x)| \leq C(1 + |x|)^{-1-\alpha}$ for $x \in S$, V has a degenerate maximum $V_o > 0$ at $x = 0$, and $V(x) = V_o - (k(x))^4$ where k is analytic in S , with $k(0) = 0$ and $k'(0) \neq 0$. The resonances for P are defined as the complex numbers $E \neq 0$ for which there exist $0 < \theta < \theta_0$ and $u \in L^2(\mathbb{R}e^{i\theta})$ such that $Pu = Eu$ and $-2\theta < \arg E \leq 0$. The location and the asymptotic behavior, as $h \rightarrow 0$, of the resonances of P are studied. Asymptotic expansions which involve the eigenvalues of the quartic oscillator $K = -\frac{d^2}{dx^2} + (k'(0)x)^4$ are obtained.

2.11.2 Resonant case, in the spectrum of a quasi-periodic Schrödinger operator

See section 2.10

2.12 Scattering metric

The following definitions are given in R.B. Melrose [74]:

2.12.1 Euclidean metric space

Let $S_+^n = \{t = (t_1, \dots, t_{n+1}) \in \mathbb{R}^{n+1}, t_{n+1} \geq 0\}$ and SP be the stéréographique projection

$$z \in \mathbb{R}^n \rightarrow \left(\frac{z}{\sqrt{1+|z|^2}}, \frac{1}{\sqrt{1+|z|^2}} \right) \in S_+^n$$

The image of \mathbb{R}^n under this map is the interior of S_+^n . The function $x = \frac{1}{|z|} = \frac{t_{n+1}}{\sqrt{1-t_{n+1}^2}}$ is a defining function for the boundary of S_+^n , which is defined on $t_{n+1} < 1$ and can be smoothly extended across $z = 0$. If we identify the collar neighborhood $\{0 \leq t_{n+1} < 1\}$ of ∂S_+^n with $(0, +\infty) \times S^{n-1}$ by the mapping

$$t \rightarrow \left(\frac{t'}{\sqrt{1-t_{n+1}^2}}, \frac{t_{n+1}}{\sqrt{1-t_{n+1}^2}} \right) = (\omega, x),$$

the euclidian metric becomes

$$\frac{dx^2}{x^4} + \frac{d\omega^2}{x^2}$$

where $d\omega^2$ is the standard round metric on S^{n-1} . Thus, if \mathbb{R}^n is replaced by its compactification, the Euclidian metric becomes a scattering metric.

2.12.2 The compact manifold case

More generally, let \mathcal{M} be a compact manifold with boundary, and x be a boundary defining function for \mathcal{M} i.e. x is a smooth positive function on \mathcal{M} such that $x = 0$ exactly on $\partial\mathcal{M}$ and $dx \neq 0$ on $\partial\mathcal{M}$. A scattering metric g on \mathcal{M} is a Riemannian metric on the interior of \mathcal{M} , which has, near the boundary, an expression

$$g = \frac{dx^2}{x^4} + \frac{h}{x^2}$$

where h is a smooth symmetric 2-tensor on \mathcal{M} , whose restriction to $\partial\mathcal{M}$ is a metric

Applications

See Wavefront sets, section 2.20, Application.

2.13 Sobolev-type spaces $M^{1,p}$ on metric-measure spaces

2.13.1 Definition of a doubling measure

Let (X, d, μ) be a metric space equipped with a Borel regular outer measure μ . Moreover μ is assumed to be doubling i.e. there exists a constant $C_\mu > 0$ such that $0 < \mu(2B) \leq C_\mu \mu(B) < \infty$ for all ball $B \subset X$. Then, there exists a constant C_o such that

$$\frac{\mu(B)}{\mu(B_o)} \geq C_o \left(\frac{r}{r_o}\right)^s \quad (45)$$

whenever $B_o = B(x_o, r_o)$, $B = B(x, r)$, $x \in B_o$, $0 < r \leq r_o$, $s = \log_2(C_\mu)$. The smallest constant s for which (45) holds is called the doubling dimension of μ .

2.13.2 Space $M^{1,p}(X)$, definition, properties

The space $M^{1,p}(X)$, $0 \leq p < \infty$ is the space of $u \in L^p(X)$ such that there exists a generalized gradient $g \in L^p(X)$, $g \geq 0$ with

$$|u(x) - u(y)| \leq d(x, y)(g(x) + g(y)),$$

μ -almost every where in X . Equipped with the norm

$$\|u\|_{1,p} = \left(\|u\|_{L^p}^p + \inf_g \|g\|_{L^p}^p \right)^{\frac{1}{p}},$$

$M^{1,p}(X)$ is a Banach space if $p \geq 1$. These spaces were defined by P. Hajlasz [53]. A good introduction to these spaces and other Sobolev type spaces on metric measure spaces, and applications such as geometric analysis, quasi conformal mappings, non-linear subelliptic equations, differential geometry, analysis of graphs, are presented in P. Hajlasz [54]. Pointwise behavior such as

Lebesgue points, Hölder continuity, for $M^{1,p}$ functions have been studied by P.Hajlasz and others. In particular, the case $p = 1$ was studied recently by J. Kinunen, H. Tuominen [62]. We recall that $M^{1,p}(\mathbb{R}^n)$ coincide with the usual Sobolev space $W^{1,p}(\mathbb{R}^n)$ if $p > 1$. This is not true for $p = 1$. And the Hardy-Littlewood maximal operator \mathcal{M} defined by:

$$\mathcal{M}h(x) = \sup_{r>0} \frac{1}{\mu(B(x,r))} \int_{B(x,r)} |h|d\mu$$

is bounded in $L^p(X)$ for $p > 1$, but is not bounded in $L^1(X)$.

2.14 Steklov eigenproblems

2.14.1 Steklov and membrane eigenvalues

See J.R. Kuttler, V.G. Sigillito [68]. Steklov eigenvalues are interpreted physically as the natural frequencies of a vibrating membrane with its mass concentrated around the edge. Three Steklov eigenvalue problems:

$$\begin{aligned} \Delta u &= 0 \text{ on } D, & \frac{\partial u}{\partial n} &= pu \text{ on } \partial D \\ \Delta^2 u &= 0 \text{ on } D, & \frac{\partial u}{\partial n} &= \frac{\partial \Delta u}{\partial n} + \xi u = 0 \text{ on } \partial D \\ \Delta^2 u &= 0 \text{ on } D, & u &= \Delta u - q \frac{\partial u}{\partial n} = O \text{ on } \partial D \end{aligned}$$

and two membrane eigenvalue problems:

$$\begin{aligned} \Delta u + \lambda u &= 0 \text{ on } D, & u &= 0 \text{ on } \partial D \text{ (fixed membrane)} \\ \Delta u + \mu u &= 0 \text{ on } D, & \frac{\partial u}{\partial n} &= 0 \text{ on } \partial D \text{ (free membrane)} \end{aligned}$$

are considered on a bounded, smooth domain $D \subset \mathbb{R}^2$. The authors obtain sharp relationships connecting the first non-zero eigenvalues p_2, ξ_2, q_1 of Steklov problems and membrane eigenvalues.

2.14.2 The harmonic Steklov eigenproblem

A function $s \in H^1(\Omega)$ is said to be a harmonic Steklov eigenfunction on Ω corresponding to the Steklov eigenvalue δ , if s satisfies:

$$\int_{\Omega} \nabla s \cdot \nabla v \, dx = \delta |\partial\Omega|^{-1} \int_{\partial\Omega} sv \, d\sigma, \quad \forall v \in H^1(\Omega).$$

Here Ω is a smooth bounded domain in \mathbb{R}^n , cf. G. Auchmuty [9]. This problem arises, in particular, as a model for the sloshing of a perfect fluid in a tank.

2.14.3 Applications

. In [10], G. Auchmuty uses harmonic Steklov eigenfunction expansion to characterize the trace spaces $H^s(\partial\Omega)$, under quite general conditions on Ω and its boundary, see section 2.16.

2.15 Strichartz-type inequality

2.15.1 Strichartz's inequality

In [92], R.Strichartz considers the solution $u(x, t)$ of

$$iu_t + \Delta u = g(x, t), \quad (x, t) \in \mathbb{R}^n \times \mathbb{R}, \quad u(x, 0) = f(x)$$

where $f \in L^2(\mathbb{R}^n), g \in L^p(\mathbb{R}^{n+1})$ with $p = \frac{2(n+2)}{n+4}$. He shows that $u \in L^q(\mathbb{R}^{n+1})$ for $q = \frac{2(n+2)}{n}$ and satisfies the inequality

$$\|u\|_q \leq C(\|f\|_2 + \|g\|_p)$$

2.15.2 Strichartz-type inequalities

Since then, **Strichartz-type inequalities** have been proved by several authors in different situations. In [84], L. Robbiano, C. Zuily study the initial value problem:

$$i \frac{\partial u}{\partial t} - Pu = 0, \quad u(\cdot, 0) = u_o \in L^2(\mathbb{R}^n)$$

where

$$P = \sum_{j,k=1}^n D_j(g^{jk}(x)D_k) + \sum_{j=1}^n (D_j b_j(x) + b_j(x)D_j) + V(x), \quad D_j = \frac{1}{i} \frac{\partial}{\partial x_j}$$

The assumptions are: the coefficients $g^{jk} = g^{kj}, b_j$ and V are real valued, b_j and $g^{jk} - \delta_{jk}$ belong to the space \mathcal{B}_{σ_o} of symbols which decay like $\langle x \rangle^{-1-\sigma_o}$, δ_{jk} is the kronecker symbol, $\langle x \rangle = (1 + |x|^2)^{\frac{1}{2}}$, $V \in L^\infty(\mathbb{R}^n)$, there exists $\nu > 0$ such that, for every $(x, \xi) \in \mathbb{R}^n \times \mathbb{R}^n$, the principal symbol $p(x, \xi)$ of P satisfies $p(x, \xi) \geq \nu|\xi|^2$; moreover, the bicharacteristic flow associated to $p(x, \xi)$ is not trapped backward not forward. Let $T > 0$ and $(q > 2, r)$ be a couple of real numbers verifying $\frac{2}{q} = \frac{n}{2} - \frac{n}{r}$, then the existence of a constant $C > 0$ such that

$$\|e^{-itP} u_o\|_{(L^q[-T+T], L^r(\mathbb{R}^n))} \leq C \|u_o\|_{L^2(\mathbb{R}^n)}$$

for all $u_o \in L^2(\mathbb{R}^n)$, is proved.

2.16 Trace space $H^s(\partial\Omega)$: an intrinsic Steklov eigenfunction expansion definition

The following result is proved in [10] (cf. section 2.14). Let Ω be a bounded, connected, open subset of \mathbb{R}^n , whose boundary $\partial\Omega$ satisfies quite general conditions; in particular, $\partial\Omega$ may be the union of a finite number of disjoint closed Lipschitz surfaces, each surface having finite area. The usual real Sobolev space $H^1(\Omega)$ is equipped with the inner product $(u, v)_\partial = \int_{\partial\Omega} \nabla u \cdot \nabla v \, dx + |\partial\Omega|^{-1} \int_{\partial\Omega} uv \, d\sigma$. Denote by Γ the trace map $H^1(\Omega) \rightarrow L^2(\partial\Omega)$. Let $0 = \delta_0 < \delta_1 \leq \dots \leq \delta_j \leq \dots$ [resp. $s_j, j \geq 0$] be the harmonic Steklov eigenvalues [resp. the corresponding ∂ -orthonormal eigenfunctions], and $\hat{s}_j = \sqrt{1 + \delta_j} \Gamma s_j$. The following definition is given, for $s \geq 0$:

$$H^s(\partial\Omega) = \left\{ g \in L^2(\partial\Omega); \sum_{j=0}^{\infty} (1 + \delta_j)^{2s} |g_j|^2 < \infty \right\},$$

where $g_j = |\partial\Omega|^{-1} \int_{\partial\Omega} g \hat{s}_j \, d\sigma$, equipped with the natural inner product. These spaces satisfy the same properties as the usual trace spaces (see J-L. Lions, E. Magenes [69]). For $s < 0$, $H^s(\partial\Omega)$ is defined by duality.

2.17 Trudinger condition

Characterisation of a class of potentials

Let $H = -\Delta + \mathcal{Q}$ be the Schrödinger operator in $L^2(\mathbb{R}^n)$, where the potential \mathcal{Q} belongs to the L. Schwartz's space of distributions $\mathcal{D}'(\mathcal{R}^n)$ (cf. L. Schwartz [87]). In [73], V. G. Mazya and I. E. Verbisky give a characterization of the Trudinger condition (see N.S. Trudinger [97]) $(P_\beta, \beta > 0)$, for \mathcal{Q} i.e. there exists $\epsilon_o > 0$ and $c > 0$ such that, for every $\epsilon \in (0, \epsilon_o)$, we have:

$$|\langle \mathcal{Q}, |u|^2 \rangle| \leq \epsilon \|\nabla u\|_{L^2(\mathbb{R}^n)}^2 + c\epsilon^{-\beta} \|u\|_{L^2(\mathbb{R}^n)}^2 \quad \forall u \in \mathcal{D}(\mathbb{R}^n)$$

Let $B_\delta(x_o)$ be the ball of radius δ centered at x_o . They prove that potentials \mathcal{Q} which satisfy (P_β) are characterized by the decomposition:

$$(1) \quad \mathcal{Q} = \operatorname{div} \vec{\Gamma} + \gamma, \quad \vec{\Gamma} \in [L_{loc}^2(\mathbb{R}^n)]^n, \quad \gamma \in L_{loc}^1(\mathbb{R}^n),$$

with the condition: there exists $\delta_o > 0$ such that, for $\delta \in (0, \delta_o)$,

$$\int_{B_\delta(x_o)} |\vec{\Gamma}(x) - \vec{m}(\vec{\Gamma})|^2 dx \leq c\delta^{n-2\frac{\beta-1}{\beta+1}} \quad \text{and} \quad \int_{B_\delta(x_o)} |\gamma(x)| dx \leq c\delta^{n-\frac{2\beta}{\beta+1}},$$

where $\vec{m}(\vec{\Gamma})$ denotes the mean value of $\vec{\Gamma}$ on $B_\delta(x_o)$ and c is independent of x_o and δ_o .

2.18 Ultraparabolic equations

Definition 7. A linear ultraparabolic equation is an equation of the form

$$\sum_1^m k_i(x, t)v_{t_i} = \sum_{i,j=1}^n a_{ij}(x, t)v_{x_i x_j} + \sum_{i=1}^n b_i(x, t)v_{x_i} + c(x, t)v + f(x, t)$$

where $x = (x_1, \dots, x_n) \in \mathbb{R}^n$, $t = (t_1, \dots, t_m) \in \mathbb{R}^m$, $m \geq 2$ and

$$\sum_{i,j=1}^n a_{ij}(x, t)\xi_i \xi_j \geq a_o \sum_{i=1}^n \xi_i^2$$

with $a_o > 0$, for every $\xi \in \mathbb{R}^n$ and for all values (x, t) in some domain \mathcal{Q}_T .

2.18.1 Singularly perturbed Regularized parabolic problem

The following problem

$$Lv = v_t + k(x, y, t)v_y - a(x, y, t)v_{xx} - b(x, y, t)v_x - c(x, y, t)v = f(x, y, t) \quad (46)$$

has been, recently, studied by D. R. Akhmetov, M.M. Lavrentiev and R. Spigler with the condition of periodicity $v|_{y=0} = v|_{y=1}$ and the initial condition $v(x, y, 0) = \varphi(x, y)$, on different domains. Equation (46) is an ultraparabolic equation with $y = t_1, t = t_2$. The coefficients in L and f [resp. φ] are defined on $\mathbb{R} \times \mathbb{R} \times [0, T]$ [resp. \mathbb{R}^2], are smooth enough and y periodic with period 1. In D.R. Akhmetov, R.Spigler [6], $\mathcal{Q}_T = \mathbb{R} \times [0, 1] \times [0, T]$. The singularly perturbed regularized parabolic problem

$$Lu^\epsilon - \epsilon u_{yy}^\epsilon = f(x, y, t) \text{ in } \mathcal{Q}_T$$

$$(u^\epsilon, u_y^\epsilon)|_{y=0} = (u^\epsilon, u_y^\epsilon)|_{y=1}, \quad u^\epsilon(x, y, 0) = \varphi(x, y)$$

is introduced and it is proved that it does not have any boundary layer, as $\epsilon \rightarrow 0$. Then ϵ -uniform estimates of u^ϵ are obtained in suitable functional spaces, according to the regularity and decay assumptions on f , φ , and the coefficients in L . The limit of u^ϵ as $\epsilon \rightarrow 0$, leads to a solution v of problem (46), which belongs to the anisotropic Sobolev space $W^{3,2,1}(\mathcal{Q}_T)$, and the anisotropic Hölder space $C^{\lambda, \lambda, \frac{1}{2}}(\mathcal{Q}_T \cap \{x \in [-K, K]\})$ for $\lambda \in (0, 1)$ and $K > 0$. Moreover, estimates of the form $|v(x, y, t)| \leq C_p e^{-p|x|}, \forall p > 0$ or $|v(x, y, t)| \leq \frac{C_m}{1 + |x|^m}, m = 0, 1, \dots$

hold in \mathcal{Q}_T . Similar results were obtained previously, for problem (46), by D.R. Akhmetov, M.M. Lavrentiev, R.Spigler [5], where $\mathcal{Q}_T = [0, 1]^2 \times [0, T]$ with additional boundary conditions on v . Other examples and applications to Markov processes, atomic physics, transport theory, chemistry, hydrodynamics, are mentioned in loc.cit. and references there.

2.18.2 A Fokker-Plank type equation

(See section 1.11). In [6], the authors consider the non linear equation

$$\frac{\partial \rho}{\partial t} = \frac{\partial^2 \rho}{\partial \omega^2} + \frac{\partial}{\partial \omega}[(\omega - \Omega - \mathcal{K}(\theta, t))\rho] - \omega \frac{\partial \rho}{\partial \theta},$$

in the unbounded domain $\mathcal{Q}_T = \{(\theta, \omega, t, \Omega) \in [0, 2\pi] \times \mathbb{R} \times [0, T] \times [-G, G]\}$, associated with the boundary and initial data $\rho|_{\theta=0} = \rho|_{\theta=2\pi}$, $\rho|_{t=0} = \rho_o(\theta, \omega, \Omega)$. Here

$$\mathcal{K}(\theta, t) = K \int_{-G}^{+G} \int_{-\infty}^{+\infty} \int_0^{2\pi} g(\Omega) \sin(\varphi - \theta) \rho(\varphi, \omega, t, \Omega) d\varphi d\omega d\Omega.$$

The authors prove that the solution obtained in [3] satisfies the estimate $|\rho(\theta, \omega, t, \Omega)| \leq C e^{-M\omega^2}$.

2.19 Virtual eigenvalue

In [8], J. Arazy and L. Zelenko consider the high order Schrödinger operator in $L^2(\mathbb{R}^d)$:

$$H_\gamma = (-\Delta)^l + \gamma V(x)$$

where $2l \geq d$, $x \rightarrow V(x)$ is a real-valued, non negative, continuous function which tends to 0 sufficiently fast, as $|x| \rightarrow \infty$, and γ is a small negative coupling constant. They study the virtual eigenvalues of H_γ i.e. the negative eigenvalues which are born at the moment $\gamma = 0$ from the end point $\lambda = 0$ of the gap $(-\infty, 0)$ of the spectrum of $(-\Delta)^l$ (cf. section 1.3).

2.20 Wavefront sets

2.20.1 The wavefront set of a distribution

(See F. Trèves [96]). Let Ω be an open set in \mathbb{R}^n . A distribution $u \in \mathcal{D}'(\Omega)$ (cf. L. Schwartz [87]) is said to be C^∞ in a neighborhood of $(x_o, \xi_o) \in \Omega \times (\mathbb{R}^n \setminus \{0\})$, if there exists a function $g \in \mathcal{D}(\Omega)$, $g \equiv 1$ in a neighborhood U of x_o and an open cone Γ_o in \mathbb{R}^n containing ξ_o such that:

$$\forall M \geq 0, \exists C_M \geq 0 \text{ such that } |(\widehat{gu})(\xi)| \leq C_M (1 + |\xi|)^{-M}, \quad \forall \xi \in \Gamma_o.$$

Here $(\widehat{gu})(\xi)$ is the Fourier transform of $gu \in \mathcal{E}'(\Omega)$, and a cone is a subset of \mathbb{R}^n , stable under the dilatations $\xi \rightarrow \rho\xi$, $\rho > 0$.

2.20.2 Wavefront set and the Weyl quantization

For the change of quantization see A. Martinez [72]. For $a(x, \xi) \in C^\infty(\mathbb{R}^d \times \mathbb{R}^d)$, its Weyl quantization, for $u \in \mathcal{S}(\mathbb{R}^d)$, is denoted by

$$a^w(x, D_x)u(x) = (2\pi)^{-d} \int \int e^{i(x-y) \cdot \xi} a\left(\frac{x+y}{2}, \xi\right) u(y) dy d\xi$$

Let $u \in \mathcal{S}'(\mathbb{R}^d)$, then, $(x, \xi) \notin WF(u)$, $\xi \neq 0$ if and only if there exists $\varphi \in \mathcal{D}(\mathbb{R}^{2d})$ such that $\varphi(x, \xi) \neq 0$ and

$$\|\varphi^w(x, hD_x)u\| \leq C_N h^N, \quad h \in (0, 1]$$

for any $N \in \mathbb{Z}_+$, where $\|\cdot\|$ denotes the L^2 norm.

2.20.3 Homogeneous wavefront set

The notion of homogeneous wavefront set was introduced by S. Nakamura [80]. Let $u \in \mathcal{S}'(\mathbb{R}^d)$, then $(x, \xi) \in \mathbb{R}^{2d} \setminus 0$ is not in the homogeneous wavefront set of u , denoted by $HWF(u)$, if and only if there exists $\varphi \in \mathcal{D}(\mathbb{R}^{2d})$ such that $\varphi(x, \xi) \neq 0$ and

$$\|\varphi^w(hx, hD_x)u\| \leq C_N h^N, \quad h \in (0, 1]$$

for any $N \in \mathbb{Z}_+$

2.20.4 Application

In [58], K. Ito studies the propagation of singularities, in terms of wavefront sets, for the solution $u_t = e^{-itH} u_o$ to the time-dependent Schrödinger equation

$$i \frac{du}{dt} = Hu, \quad H = \frac{1}{2} \Delta + V, \quad u(0) = u_o \in L^2(\mathbb{R}^n)$$

where Δ is the Laplace-Beltrami operator with respect to a scattering metric g given on S_+^n (cf. section 2.12), and V is a smooth subquadratic potential. Suppose $(z_o, \zeta_o) \in T^*(\mathbb{R}^n)$ is backward nontrapping and let $\omega_- = -\lim_{t \rightarrow -\infty} \frac{z(t; z_o, \zeta_o)}{|z(t; z_o, \zeta_o)|}$, where $z(t; z_o, \zeta_o)$ is solution of the Hamilton equations. It is proved that, if there exists $t_o > 0$ such that $(-t_o \omega_-, \omega_-) \notin HWF(u_o)$, then $(z_o, \zeta_o) \notin WF(u_{t_o})$.

I mention the notion of **quadratic scattering wavefrontset** introduced in R.B. Melrose [74] and also used in [58].

Acknowledgement

I am grateful to Didier Gemmerlé for his help in the practice of L^AT_EX. Without him, this article would not exist.

References

- [1] J.A. Acebron, R. Spigler, Adaptive frequency model for phase-frequency synchronization in large populations of globally coupled nonlinear oscillators, *Physical Review Letters*, **81** no.11 (1998), 2229–2232.
- [2] Adimurthi, O. Druet, Blow-up analysis in dimension 2 and a sharp form of the Moser-Trudinger inequality, *Communications in Partial Differential Equations*, **29** no.1–2 (2004), 295–322.
- [3] D.R. Akhmetov, M.M. Lavrentiev JR., R. Spigler, Regularizing a nonlinear integro-parabolic Fokker-plank equation with space periodic solutions, existence of strong solutions, *Siberian Mathematical Journal*, **42** no.4 (2001), 693–714.
- [4] D.R. Akhmetov, M.M. Lavrentiev JR., R. Spigler, Existence and uniqueness of classical solutions to certain nonlinear integro-differential Fokker-Planck type equations, *Electronic Journal of Differential Equations*, **no.24** (2002), 1–17.
- [5] D.R. Akhmetov, M.M. Lavrentiev JR., R. Spigler, Singular perturbations for certain partial differential equations without boundary-layers, *Asymptotic Analysis*, **35** (2003), 65–89.
- [6] D.R. Akhmetov, R. Spigler, Uniform and optimal estimates for solutions to singularly perturbed parabolic equations, *Journal of evolution equations*, **7**(2007), 347–372.
- [7] S. Amroui, H. Labani, Global existence and maximal attractor of facilitated diffusion model, *Forum Mathematicum*, **15** (2003), 923–933.
- [8] J. Arazy and L. Zelenko, Virtual eigenvalues of high order Schrödinger operator, *Integral Equations and Operator Theory*, **55** (2006), 189–231 and 305–345.
- [9] G. Auchmuty, Steklov eigenproblems and the representation of solutions of elliptic boundary value problems, *Numerical Functional Analysis and Optimization*, **25** no 3-4 (2004), 321–348.
- [10] G. Auchmuty, Spectral characterization of the trace spaces, *Siam Journal of Mathematical Analysis*, **38** no. 3 (2006), 894–905.

- [11] H. Baklouti, M. Mnif, Asymptotique des résonances pour une barrière de potential dégénérée, *Asymptotique Analysis*, **47** (2006), 19–48.
- [12] V. Bangert, *Bulletin of the American Mathematical Society*, **42** no. 2 (2005), 245–249.
- [13] T. Bartsch, T. Weth, The effect of the domain’s configuration of nodal solutions of singularly perturbed elliptic equations, *Topological Methods in Nonlinear Analysis*, **26** no.1 (2005), 109–133.
- [14] H. Baumgärtel, *Analytic perturbation theory for matrices and operators*, Operator Theory, Advances and Applications, vol.15, Birkhäuser, (1985).
- [15] H. Berestycki, L. Nirenberg, On the method of moving planes and sliding method, *Bulletin of the Brazilian Mathematical Society*, **22** no.1 (1991), 1–37.
- [16] S. Berstein, Sur une classe d’équations fonctionnelles aux dérivées partielles, *Izvestiya Akademii Nauk SSSR, Seriya Matematicheskaya* **4** (1940), 17–26.
- [17] S. Bodine and D.A. Lutz, Asymptotic Analysis of solutions of a radial Schrödinger equation with oscillating potential, *Mathematische Nachrichten*, **279** no. 15 (2006), 1641–1663.
- [18] A. Bonfoh, M. Grasselli, A. Miranville, Long-time behavior of a singular perturbation of the viscous Cahn-Hilliard-Gurtin equation, *Mathematical Methods in the Applied Sciences*, **31** (2008), 695–734.
- [19] H. Brezis, *Analyse Fonctionnelle, Théorie et Applications*, Collection Mathématiques Appliquées pour la maîtrise, Masson (1983).
- [20] J.W. Cahn, On spinodal decomposition, *Acta Metallurgica Sinica*, **9** (1961), 785–801.
- [21] W. Chen, M.J. Ward, Oscillatory instabilities and dynamics of multi-spike patterns for the one-dimensional Gray-Scott model, *European Journal of Applied Mathematics*, **20** (2009), 187–214.
- [22] F. Camilli, A. Cesaroni, A note on singular perturbation problems via Aubry-Mather theory, *Discrete and Continuous Dynamical Systems*, **17** no. 4 (2007), 807–819.
- [23] V.V. Chepyzhov, M.I. Vishik, *Attractors for Equations of Mathematical Physics*, Colloquium Publications, American Mathematical Society **49** (2002).
- [24] E.A. Coddington and N. Levinson *Theory of Ordinary Differential Equations*, Mac-Grall-Hill Book Company (1955).

- [25] M. Conti, V. Pata, M. Squassina, Singular limit of differential systems with memory, *Indiana University Mathematics Journal*, **55** no. 1 (2006). 169–215.
- [26] R. Courant and D. Hilbert *Method of mathematical Physics vol. 1*, Interscience (1953).
- [27] J.D. Crawford, Amplitude expansions for instabilities in populations of globally-coupled oscillators, *Journal of statistical physics*, **74** nos.5–6 (1994).
- [28] : J. Crema, A.S. do Nascimento, On the role of the equal-area condition in internal layer stationary solutions to a class of reaction-diffusion systems, *Electronic Journal of differential Equations*, **99** (2004), 1–13 .
- [29] C. Dafermos, Asymptotic stability in viscoelasticity, *Archive for rational mechanics and analysis*, **37** (1970), 297–308.
- [30] P. D’Ancona and S. Spagnolo, A class of nonlinear hyperbolic problems with global solutions, *Archive for Rational Mechanics and Analysis*, **124** (1993), 201–219.
- [31] J. Davil, On an open question about functions of bounded variation, *Calculus of Variations and Partial Differential Equations*, **15** no. 4 (2002), 519–527.
- [32] A. Debussche, A singular perturbation of the Cahn-Hilliard equation, *Asymptotic Analysis*, **4** (1991), 161–185.
- [33] G. Di Fazio, C.E. Gutierrez, E. Lanconelli, Covering theorems, inequalities on metric spaces and applications to PDE’s, *Mathematische Annalen*, **341** (2008), 255–291.
- [34] P. Djakov, B. Mityagin, Instability zones of a periodic 1D Dirac operator and smoothness of its potential, *European Journal of Applied Mathematics*, **16** (2005), 201–237.
- [35] A. Doelman, R.A. Gardner, T.J. Kaper, Stability analysis of singular patterns in the 1D Gray-Scott model: a matched asymptotics approach, *Physica D*, **122** (1998) 1-36.
- [36] A. Doelman, R.A. Gardner, T.J. Kaper, A stability index analysis of 1-D patterns of the Gray-Scott model, *Memoirs of the American mathematical Society* , **737** (2002).
- [37] A. Eizenberg, Elliptic perturbations for a class of hamilton-Jacobi equations, *Asymptotic Analysis*, **7** (1993), 251–285.

- [38] *Encyclopaedia of Mathematics*, Springer Online Reference Works, Category.
- [39] *Encyclopaedia of Mathematics*, Springer Online Reference Works, Diffusion process, Langevin equation, and Kolmogorov equation.
- [40] M. Essen, S. Janson, L. Peng, J. Xiao, \mathcal{Q} spaces of several real variables, *Indiana University Mathematics Journal*, **49** no.2 (2000), 575–615.
- [41] P. Exner, A. Mantile, On the optimization of the principal eigenvalue for single-center point-interaction operators in a bounded region, *Journal of Physics A: Mathematical and Theoretical*, **41** no.6 (2008), 15 pp.
- [42] K. Falconer, *Fractal geometry*, Mathematical foundations and applications, John Wiley & Sons (1990).
- [43] K. Falconer, *Techniques in fractal geometry*, John Wiley & Sons, (1997).
- [44] A. Fathi, A. Siconolfi, PDE aspects of Aubry-mather theory for quasiconvex Hamiltonians, *Calculus of Variations*, **22** (2005), 185–228.
- [45] A. Fedotov, F. Klop, The spectral theory of adiabatic quasi-periodic operators on the real line, *Markov Processes and Related Fields*, **9** (2003), 579-614.
- [46] A. Fedotov, F. Klop, Level repulsion and spectral type for one-dimensional adiabatic quasi-periodic Schrödinger operators, In *Lecture notes in Physics*, Springer, Berlin **690** (2006), 383–402.
- [47] S. Gatti, M. Grasselli, V. Pata, Exponential attractors for a phase-field model with memory and quadratic nonlinearities, *Indiana University Mathematic Journal*, **53** no. 1 (2004), 719–753.
- [48] S. Gatti, M. Grasselli, A. Miranville, V. Pata, Hyperbolic relaxation of the viscous Cahn-Hilliard equation in 3-D, *Mathematical Models and Methods in Applied Sciences*, **15** no.2 (2005), 165–198.
- [49] M. Ghisi, M. Gobino, Global existence and asymptotic behavior for a mildly degenerate dissipative hyperbolic equation of Kirchhoff type, *Asymptotic analysis*, **40** (2004), 25–36.
- [50] M. Ghisi, M. Gobino, Hyperbolic-parabolic singular perturbations for mildly degenerate Kirchhoff equations, *Journal of Differential Equations*, **245** (2008), 2979–2007.
- [51] M. Grasselli, V. Pata, Uniform attractors of nonautonomous dynamical systems with memory, In *Progress in Nonlinear Differential Equations and their applications*, **50**, Birkhäuser, Basel (2002), 155–178.

- [52] M.E. Gurtin, Generalized Ginsburg-Landau and Cahn-Hilliard equations based on a microforce balance, *Physica D*, **92** (1996), 178–192.
- [53] P. Hajlasz, Sobolev spaces on an arbitrary metric space, *Potential Analysis*, **5** no.4 (1996), 403–415.
- [54] P. Hajlasz, Sobolev spaces on metric measure spaces, In *Contemporary mathematics*, **338**, American Mathematical Society (2003), 173–218.
- [55] E.M. Harrell, P. Kröger, K. Kurata, On the placement of an obstacle or a well so as to optimize the fundamental eigenvalue, *Siam Journal on Mathematical Analysis*, **33** no. 1 (2001), 240–259.
- [56] M. and T. Hoffman-Ostenhof, N. Nadirashvili, On the nodal line conjecture, *Advances in Differential Equations and Mathematical Physics, Comtemporary Mathematics*, **217** (1998), 33-48.
- [57] D. Huet, *Décomposition spectrale et opérateurs*, Presses Universitaires de France (1976).
- [58] K. Ito , Propagation of singularities for Schrödinger equations on the Euclidean space with a scattering metric, *Communications in Partial Differential Equations*, **31** (2006), 1735–1777.
- [59] A.R. Its, Asymptotic behavior of the solutions of the radial Schrödinger equation with oscillating potential for the zero value of the energy, *Problems in Mathematical Physics, Leningrad*, **9** (1979), 30–41 and 183–184, translated in *Selecta Mathematica Sovietica*, **3** (1984), 291–300.
- [60] F. John, L. Nirenberg, On functions of bounded mean oscillation, *Communications on pure and applied Mathematics* , **14** (1961), 415–426.
- [61] T.Kato, *Perturbation theory for linear operators*, Springer (1966).
- [62] J. Kinnunen, H. Tuominen, Pointwise behavior of $M^{1,1}$ Sobolev functions , *Mathematische Zeitschrift*, **257** (2007), 613–630.
- [63] G. Kirchhoff, *Vorlesungen uber Mechanick*, Teubner, Leipzig (1883).
- [64] O. Knill, *Jürgen moser, selected chapters in the calculus of variations*, Birkhäuser Verlag (2003).
- [65] T. Kolokolnikov, J. Wei, On ring-like solutions for the Gray-Scott model: existence, instability and self- replicating rings, *European Journal of Applied Mathematics*, **16** (2005), 201–237.
- [66] Y. Kuramoto, Self entrainment of a population of coupled non-linear oscillators, In *International Symposium on mathematical problems in theoretical physics, H.Araki editor, lecture Notes in Physics*, **39**, Springer (1975), 420–422.

- [67] Y. Kuramoto, *Chemical oscillations, waves, and turbulence*, Springer Series in Synergetic, **19**, Berlin (1984).
- [68] J.R. Kuttler, V.G. Sigillito, Inequalities for membrane and Steklov eigenvalues , *Journal of Mathematical Analysis and Applications*, **23** (1968), 148–160.
- [69] J-L. Lions, E. Magenes, *Problèmes aux limites non homogènes and applications*, Dunod (1968).
- [70] P-L. Lions, *Generalized solutions of Hamilton-Jacobi equations*, Research Notes in Mathematics, Pitman, London (1982).
- [71] L.A. Lyusternik, L. Schnirelman, *Methodes toptologiques dans les problemes variationnels*, Gauthier-Villars (1934).
- [72] A. Martinez, *An introduction to semiclassical and microlocal analysis*, Universitext, Springer, New York (2002).
- [73] V.G. Mazya and I.E. Verbisky, Infinitesimal form boundedness and Trudinger’s subordination for the Schrödinger operator, *Inventiones Mathematicae*, **162** no.1 (2005), 81–136.
- [74] R.B. Melrose, Spectral and scattering theory on asymptotically Euclidean spaces, In *M. Ikawa (ed.), Spectral and Scattering Theory, Lecture Notes in pure and Applied Mathematics*, **161**, Marcel Dekker, New York (1994), 85–130.
- [75] B. Merlet, Two remarks on liftings of maps with values into S^1 , *Comptes rendus des Séances de l’Académie des Sciences, Paris, Série I*, **343** (2006), 467–472.
- [76] D.S. Morgan, T.J. Kaper , Axisymmetric ring solutions of the 2D Gray-Scott model and their destabilization into spots, *Physica D*, **192** no.1-2(2004), 33-62.
- [77] M. Morse, A fundamental class of geodesics on any closed surface of genus greater than one, *Transactions of the American Mathematical Society*, **26** (1924), 25–60.
- [78] J. Moser, A sharp form of an inequality by N. Trudinger, *Indiana university Mathematic Journal*, **20** no. 11 (1971), 1077-1092.
- [79] R.J. de Moura, A.S. do Nascimento, The role of the equal-area condition in internal and superficial layered solutions to some nonlinear boundary value elliptic problems, In *Progress in Nonlinear Differential Equations and their Applications*, Birkhäuser **66** (2006), 415–427.

- [80] S.Nakamura, Propagation of the homogeneous wavefront set for Schrödinger equations, *Duke Mathematical Journal*, **126** no.2 (2005), 349–367.
- [81] K. Nakashima, M. Urano, Y. Yamada, Transitions layers and spikes for a bistable reaction-diffusion equation, *Advances in Mathematical Sciences and Applications*, **15** no.2 (2005), 683–707.
- [82] A.S. do Nascimento, Inner transition layers in an elliptic boundary value problem: a necessary condition, *Nonlinear Analysis*, **44** (2001), 487–497.
- [83] L.E. Payne, Isoperimetric inequalities and their applications, *Siam Review*, **9** (1967), 453–488.
- [84] L. Robbiano, C.Zuily, Strichartz estimates for Schrödinger equations with variable coefficients, *Mémoires de la Société Mathématique de France*, **101–102** (2005).
- [85] H.Sakaguchi, Cooperative phenomena in coupled oscillator systems under external fields, *Progress in theoretic Physics*, **79** no. 1 (1988),39–46.
- [86] M. Schechter, *Principles of functional analysis*, Academic Press, New-York (1971).
- [87] L. Schwartz, *théorie des distributions*, Hermann, Paris (1966).
- [88] L. Schwartz, *Analyse, Topologie Générale and analyse fonctionnelle*, Hermann (1970).
- [89] J. Serrin, A symmetry problem in potential theory, *Archive for Rational Mechanics and Analysis*, **43** (1971), 304–318.
- [90] A. Siconolfi, Metric character of Hamilton-Jacobi equations, *Transactions of the American Mathematical Society*, **355** no.5 (2003), 1987–2009.
- [91] S. Spagnolo , The cauchy problem for Kirchhoff equations, In *Proceedings of the second International Conference on partial Differential Equations, held in Milan, September 28–30, 1992, Rendiconti del Seminario Matematico e fisico di Milano*, **62**, (1992), 17–51.
- [92] R. Strichartz, Restriction of fourier transform to quadratic surfaces and decay of solutions to the wave equation, *Duke Mathematical Journal*, **44** (1977), 705–714.
- [93] R. Strichartz, Bounded mean oscillation and Sobolev space, *Indiana University Mathematics Journal*, **29** no.4 (1980), 539–558.

- [94] S.H. Strogatz, From Kuramoto to Crawford: exploring the onset of synchronization in populations of coupled oscillator, *Physica D*, **143**, (2000), 1–20.
- [95] E.C. Titchmarsh, *The Theory of Functions*, second edition, Oxford University Press (1988).
- [96] F. Trèves, *Introduction to pseudodifferential operators and Fourier integral operators, volumes I and II*, Plenum Press, New York and London (1980).
- [97] N.S. Trudinger, Linear elliptic operators with measurable coefficients, *Annali della Scuola Superiore di Pisa*, **27**, (1973), 265–308.
- [98] N.S. Trudinger, On imbedding into Orlicz spaces and some applications, *Journal of Mathematics and Mechanics*, **17** (1967), 473-483.
- [99] Z.X. Wang, D.R. Guo, *Special functions*, World Scientific (1989).
- [100] J. Xiao, Homothetic variant of fractional Sobolev space with application to Navier-Stokes system, *Dynamics of Partial Differential Equations*, **4** no.3 (2007), 227–245.
- [101] Y. Yang Extremal functions for a sharp Moser-Trudinger inequality, *International Journal of Mathematics*, **17** no. 3 (2006), 331-338.
- [102] Y. You, Multiple-spike ground state solutions of the Gierer-Meinhardt equations for biological activator-inhibitor systems, *Dynamics of Partial Differential Equations*, **2** no. 3 (2005), 187–260.

Figure captions

- Figure 1. The Cantor set p. 3
- Figure 2. The Sierpinski gasket p. 13
- Figure 3. The Sierpinski carpet p. 13
- Figure 4. The $\alpha - \beta$ plane p.24
- Figure 5. Spectral band p.30