



HAL
open science

Master Interface for On-Chip Hardware Accelerator Burst Communications

Antoine Fraboulet, Tanguy Risset

► **To cite this version:**

Antoine Fraboulet, Tanguy Risset. Master Interface for On-Chip Hardware Accelerator Burst Communications. The Journal of VLSI Signal, 2007, 49 (1), pp.73-85. 10.1007/s11265-006-0045-2. hal-00391222

HAL Id: hal-00391222

<https://hal.science/hal-00391222v1>

Submitted on 3 Jun 2009

HAL is a multi-disciplinary open access archive for the deposit and dissemination of scientific research documents, whether they are published or not. The documents may come from teaching and research institutions in France or abroad, or from public or private research centers.

L'archive ouverte pluridisciplinaire **HAL**, est destinée au dépôt et à la diffusion de documents scientifiques de niveau recherche, publiés ou non, émanant des établissements d'enseignement et de recherche français ou étrangers, des laboratoires publics ou privés.

Master Interface For On-Chip Hardware Accelerator Burst Communications

Antoine Fraboulet Comsys, Lip 46 Allée d'Italie 69363 Lyon cedex 07 France antoine.fraboulet@insa-lyon.fr	Tanguy Risset Citi, Insa-Lyon, 21 av. Jean Capelle 69621 Villeurbanne Cedex France tanguy.risset@ens-lyon.fr
--	---

Abstract

We explain a systematic way of interfacing data-flow hardware accelerators (IP) for their integration in a system on chip. We abstract the communication behaviour of the data flow IP so as to provide basis for an interface generator. Then we measure the throughput obtained for different architectures of the interface mechanism by a cycle accurate bit accurate simulation of a SoC integrating a data-flow IP. We show in which configuration the optimal communication scheme can be reached.

Keywords: system on chip, SoC simulation, high level synthesis, interface generation

1. Introduction

Large scale systems on chip (SoC) design is faced with many problems among which efficient communication managing is one of the most important. In the past, communication efficiency has already been one of the major burden in parallel machine development but in addition, today's on-chip communications are limited by the power consumption problem. Network on chip based SoC architectures are not arriving as fast as envisaged because of the power consumption problem. In addition, shorter design time is required to meet the ever increasing time-to-market constraints. IP re-use and platform based design are pointed out as solution to faster design but they are still confronted with important limitations and are not really used in today's industrial design flows. Examples of these problems are: IP standardisation, system on chip cycle accurate simulation time [22, 21], and fast integration of special purpose hardware in a design environment.

We address the problem of providing a rapid and efficient integration of a special purpose hardware accelerator into a complex system on chip possibly integrating many processor cores and important software applications. More precisely, we will focus on the category of *stream processing* hardware accelerators. Stream processing performs on-the-fly costly computations on streams of data. The amount of control in these computations is reduced, but the complexity lies in the quantity of computations usually submitted to soft real time constraints (as for audio or video processing). Hardware accelerators containing parallel computation usually presented in the form of arrays of processors are mandatory to meet these constraints. we refer to these accelerators as *data-flow* IPs. Systolic arrays are examples of such data-flow IPs but they are not the only ones. In this paper we only target linear array of processor which have a small number of input/output ports, the problem of interfacing 2D array of processors has been studied in [7], but the problems

encountered are quite different and many IP integrated to SoC are 1D arrays because of the high bandwidth required by 2D arrays.

The hardware accelerators used in SoC for portable communication systems (cell-phones, PDA,...) are originally designed by hardware designers in collaboration with signal processing engineers. For these IPs, the performance bottleneck lies in the communication of the data between memory and the IP. The paradigm used for specifying and designing these circuits is called the *data-flow* model: designers manipulates streams of data which input and output the circuits without any information about the external storage of these data. The interface protocol is *data synchronised* which means that the behaviour is regulated by the consumption and production of data at the boundaries of the architecture. In this protocol, if the data is not present the computations are stopped, usually with a clock enable mechanism.

Until recently, these IPs were designed by hand with a precise methodology, knowing in advance the target SoC architecture. Hence the design of the interface was more or less performed together with the architecture. New trends in SoC design require the use of tools to accelerate the design phase of specific hardware accelerators. These tools are called *high level design, behavioural synthesis* tools or *hardware compilers* [11, 5, 24]. Most of the time, because of the huge design space they propose to the user a toolbox for tuning parameters of the resulting architecture. However, even if these tools greatly accelerate and secure the design of the IP itself, the time needed to write the interface may render the tool simply useless. Today, these tools produce some configuration information that helps in the design of the interface, but this part has not been standardised. In this paper, based on the experience of MMAAlpha [8, 10] and Gaut [5], we identify the common concepts that are used by data-flow IP designers to propose a generic interface mechanism. This generic interface mechanism will be parameterised by the configuration information output from data-flow IP generators. We also hope to bring a standard way of describing data-flow IP input/output behaviour so as to facilitate IP reuse.

We introduce in this paper some theoretical foundations for the automatic generation of data-flow IPs interface. As a reference to data-flow *model of computation* used to build IPs, we introduce the data flow *model of interface* which basically rely on a data synchronised protocol. We highlight the various parameters that must be taken into account to adapt the data-flow IP to various SoC platform and we validate this high level interface design concept by a complete cycle accurate SoC simulation using the SocLib simulation environment and a high level designed hardware accelerator synthesised with the MMAAlpha tool [11]. We provide many experimental results concerning communication performances for various architecture of the interface. The major conclusion of this work is that optimal communication scheme can be reached only if the interface of the hardware accelerator is master, i.e. contains a DMA, and moreover this DMA has to have a small degree of programmability: it must be able to execute repeatedly a small sequence of transfers.

2. Hardware/Software Interface Of Data-Flow IPs

In this section, we precisely identify the context of the work, it implies precise definition of what we call data-flow IP, the schematic architecture of the system on chip we target and the overall principles of the hardware/software interface that we wish to generate.

2.1. Data flow IP and SoC environment

In recent SoC design, many processors IPs are to be connected on a communication medium which can be a bus, a hierarchical bus or a network. We will refer to this communication medium as the *bus* even if this work can be applied to network on chip based SoC architectures. The processors are usually *initiators*, in the sense that they initiates communications. In addition, several other

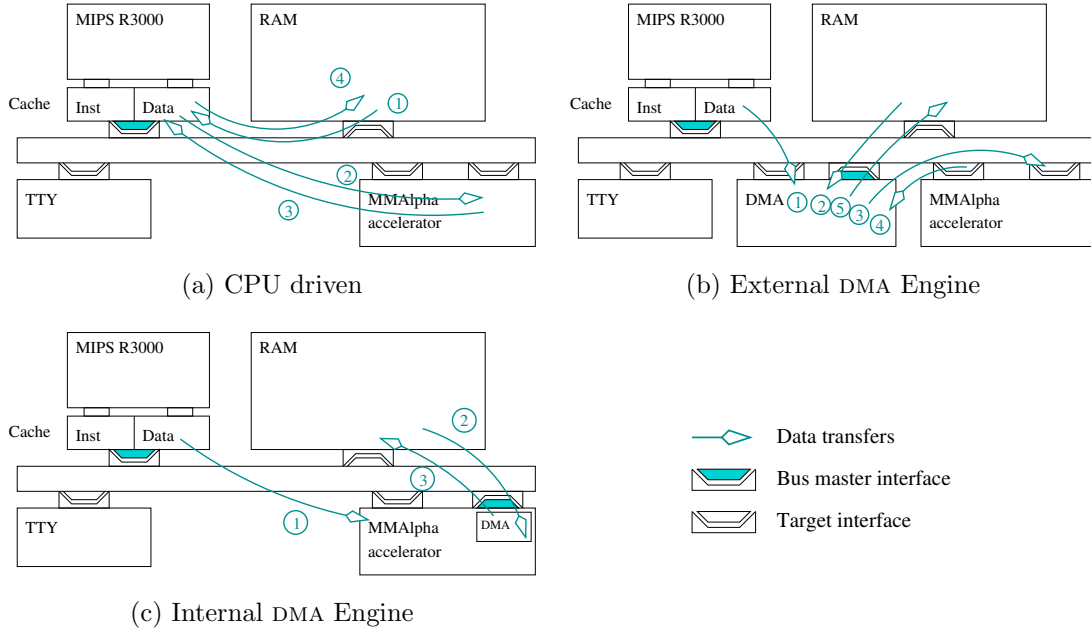

Figure 1. The three main interface modes: (a) CPU driven, (b) external DMA and (c) internal DMA engine

IPs are connected on the bus: memory, hardware accelerators, external communication systems, bridge to other buses and so on. In most recent SoC architectures the only hardware to be designed specifically will be some hardware accelerator dedicated to a particular algorithm to be executed on the SoC.

From the external communications point of view, a data flow IP is a black box controlled by data arrival which receives and sends data possibly at each clock cycle. It has a number of input ports and output ports each of which having a certain bit-width. We assume that, in addition to the clock, the IP has a *clock enable* pin that can freeze the execution of the IP. Hence, if the clock enable is not set, everything behave in the IP as if the clock was not changing. This allow us to define the notion of *virtual clock*, the virtual clock is the one seen inside the IP, it does not take into account the clock changes that are not validated by the clock enable. Then, we assume that the IP is data synchronised, i.e. at each clock cycle, data are presented on the input port and at the raise of the clock (provided that the clock enable is set), the data is read by the IP. If all the required data are present and the clock enable is set then the IP can run for a cycle which increments the virtual clock counter. We do not assume that there is a hand shake protocol at this level of abstraction. In practice there is a hand shake protocol at a lower level, but it can be abstracted thanks to the virtual clock mechanism.

The target SoC platform is represented on Fig. 1, IPs are connected to the bus via the VCI interface protocole. VCI [1] is a low level point to point protocol standardised by the VSI Alliance and permits to interconnect IPs independently of the protocol used by the bus. A MIPS processor executes a stream-processing like application and uses a hardware IP to accelerate computations. The IP has been generated with MMAAlpha high level synthesis tool [11], hence it is named *MMAAlpha accelerator* in Fig. 1.

2.2. Hardware/Software Interface Global Scheme

In general we assume that the hardware accelerator will be controlled by a processor (that we call the *host* processor). Hence the interface of the IP is composed of a software part and a hardware

part. The software part will command the data communication between memory and the IP, we call this part the *driver*. From our experience [8, 10], the communication scheme used to feed the hardware accelerator must respect important constraints so as to obtain acceptable performances: (i) it should try to use a Direct Memory Access module (DMA) to perform communication in burst mode, but only when it increases performances; (ii) the designer can set the burst size to balance between hardware cost, communication latency and bus contention. Also, the architecture of the hardware/software interface must be re-usable for many different data-flow IP. It can be envisaged in three main modes depicted in Fig. 1: either the driver on the host processor directly executes all the communications or it simply controls a DMA which himself performs the communications between the memory and the IP. The use of this DMA can be made much more efficient if the DMA is designed specifically to this generic interface control mechanism and is directly connected to the IP as shown on 1-c and demonstrated in section 4. The proposed interface mechanism must be used in various SoC architectures, hence we think that an *interface generator* tool must be used to generate various versions of the interface depending on targeted SoC parameters, this is detailed in next section.

3. Generic Interface Generation Principles

In this section we identify the concept that are useful to build an interface generator for data-flow IPs.

3.1. Communication Activity Abstraction

The crucial point is to abstract the IP communication activity in such a way that it is (i) platform independent and (ii) compact. To be platform independent, one has to identify the communication activity that depends only of the IP. To be compact one must use loop like formalism to express a large number of communication in a very small space. The use of parameters not known at compile time in these loop is mandatory. The theoretical background of our work is based on the polyhedral model which uses polyhedra to abstract loop iteration domains. However, interface synthesis for linear arrays does not need a important knowledge on polyhedra as the only polyhedra manipulated are 1-dimensional.

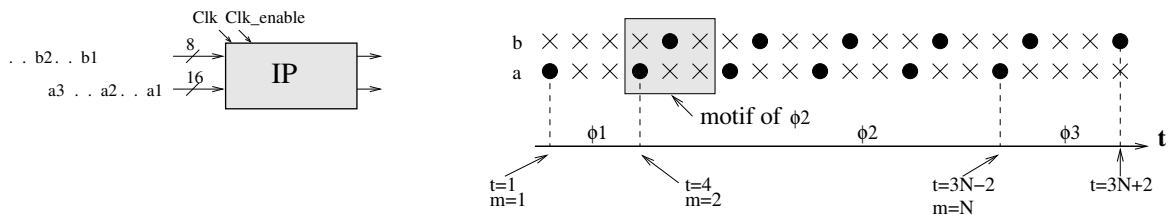

Figure 2. Graphical representation of input/output on a simple data-flow IP

Consider a very simple example: a hardware module that processes two streams a_1, a_2, \dots and b_1, b_2, \dots (only the input interface is detailed here). The a stream is 16 bits wide while the b stream is 8 bits wide. This IP inputs the first a sample at $t = 1$ and then one a sample every three clock cycle until N samples have been processed. The t counter corresponds to a counter on the virtual clock of the IP hence we are currently observing the behaviour from *inside* the module, it is initialised with the reset of the IP. The b stream is input at the same rate (one sample every 3 clock cycles) but starts at $t = 5$. The IP is represented on the left of Fig. 2, many signal processing filters have the same kind of input/output behaviour: each stream is composed of a sequence of *samples* arriving at a regular rate. The schedule of the inputs can be graphically represented by the right of Fig. 2, for $N = 6$.

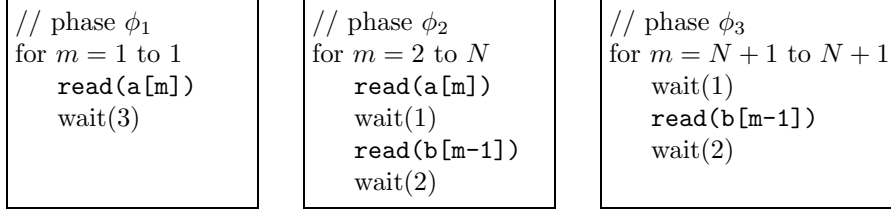

Figure 3. Data flow interface format used for specifying input/output behaviour of the IP of Fig. 2

The input interface behaviour has three *phases*. During the first phase, only **a** is input, then **a** and **b** are input, and finally there is a phase where only **b** is input. Because of the stream processing behaviour of the application, we can divide each of these phases into the repetitive execution of a *motif* which corresponds to the consumption of one sample of each stream (right of Fig. 2). We define a *motif* as a small sequence of steps (here 3 steps) where I/O performed by each port are precisely defined. Here, each sample of stream **a** is input every 3 clock cycles. Hence, the I/O behaviour on port **a** can be described as a repetitive execution of a simple motif: one step with input and two steps without input. The motif of stream **b** has the same length, hence the I/O behaviour during phase ϕ_2 can be expressed as $N - 1$ execution of a simple motif which is illustrated on the right of Fig. 2. In general the length of the motif of a phase is the least common multiple of the length of the motifs of all the streams involved.

To specify functional behaviour of the IP, the motif index m can be used rather than the virtual clock t . Of course, as we are in the data flow model, there will always be a relation between the motif index m and the virtual clock counter t . For our example, this relation can be expressed as: in phase ϕ_2 the motif m start its execution at $t = 3m - 2$, this relation can be easily established once the motif has been defined. In addition we need a way to identify which data is concerned with a particular motif m . For that we assume that data input on a particular port are successive elements of a linear array. Any other indexing is possible, however, it should be as close as possible as the memory layout of the corresponding variable in a target SoC.

We gather the phase and motif information into the *data-flow interface format* presented in Fig. 3 which permits to represent the input behaviour of the architecture of Fig. 2 without assigning a value to N . In these loops, the m index is the motif index or equivalently the number of the sample treated. The virtual clock counter t can be reconstructed using the `wait` instructions. The instructions have a 0 cycle execution time except the `wait()` statement whose execution time is the argument. The phases and motifs completely define the communication behaviour of the IP. Any IP whose input/output behaviour cannot be expressed with these concepts cannot be interfaced by our mechanism. Note that it strictly implies data-independent communications, the communication scheme must be statically defined before the computation starts.

This data-flow interface format should be parsed by the interface generator. During this process, the polyhedral model can be used to store the internal representation of the phase and motif information. For instance, the virtual clock cycles at which the IP should read on port **a** are the integers of the following set: $\{ 3m - 2 \mid 2 \leq m \leq N \}$. This set is called a \mathbb{Z} -polyhedron. Researches on the polyhedral model [23] have shown how to store and manipulate these sets without knowing the value of N . Building this set during the parsing of the data-flow interface program of Fig. 3 is easy.

The scheme of the interface mechanism is depicted in Fig. 4, it will be explained in next section. Just note that FIFOs are placed between the bus and the IP to buffer the data. In order to integrate the IP into a SoC, we need some more information, in particular the size of the bus and the size available for the FIFOs used to buffer data before the IP. we define the communication scheme by a succession of *communication pattern* inside each phase: a *communication pattern* is the set of data that will be sent to the architecture to feed the architecture during a particular phase. A pattern can gather several motifs in order to take advantage of the bus burst mode. Input pattern and output

pattern must be carefully merged taking into account buffering available to avoid deadlocks. On our example, during phase ϕ_2 , if we have FIFOs containing 20 data of **a** and **b** before IP input ports, and assuming that the bus width is 32 bits, we can use the following pattern: send 10 bus-words of **a**, then send 5 bus-words of data **b** (remember that **b** has a twice smaller bit width).

To sum up the important concepts that we have introduced in this section:

- The input/output behaviour of the IP is divided into a finite number of *phases*. A phase is a period during which communication occurs only on (possibly many) fixed ports.
- A phase repeats from one to a very large number of time (possibly fixed at run time) a *motif*. A motif has a fixed number of virtual clock cycle. It describes the repeated behaviour of the input and output of the interface for each sample during a particular phase.
- A *pattern* (or communication pattern) is the set of data that will be sent to the architecture to feed the architecture during a particular phase.

3.2. Generic Interface Description

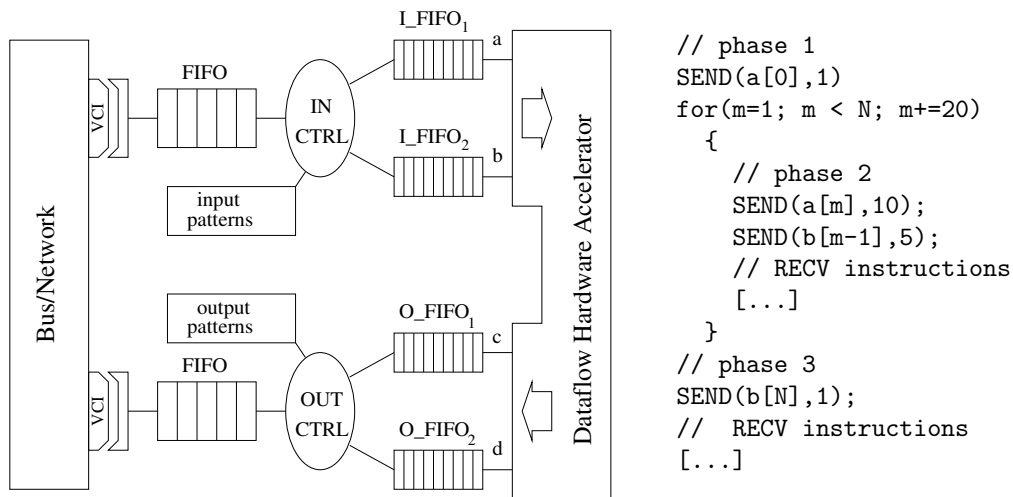

Figure 4. Hardware and Software interfaces for the Data-flow hardware accelerator of Fig. 3. Controllers must be configured according to communication patterns used in the software driver on the right hand side.

We are now able to introduce the basic architecture of our interface mechanism. It is represented on Fig. 4 with a maximum burst size of 10 bus words. The hardware part is on the left. The proposed architecture has two target interfaces on the interconnect. These two ports can be reduced to one if simultaneous input and output are not feasible as it is the case when the interconnect is a bus. Data received from the host processor through the bus are de-multiplexed according to the communication pattern of the current phase. The hardware performing this control is a simple automaton parameterised by phases, motifs and communication patterns, we call it the *controller*. The software driver executed on the host processor is represented on the right. One can see how the patterns are used to write the driver (only input instructions are detailed). The compatibility between the controller configuration and the driver is essential, both should be generated by the same tool. This is the major argument for an interface generator.

The interface generator reads input/output behaviour of the IP expressed in a particular format such as the data-flow interface format presented in Fig. 3 and produces the corresponding hardware

controller and software driver. This generator should be able to include many parameters in addition to the IP parameters. For instance, the designer should be able to specify the maximum size of burst allowed, as well as the size of the FIFOs present in the interface generated. A good interface generator should be insensitive to a change of master processor, i.e. it should be easily retargeted to a new assembly language or interruption handling strategy.

Finally the interface generator should be adaptable to different memory layout of the streams. The difficult part is to make the phase/motif information and the memory layout organisation compatible. In our version, we have assumed that successive data that enters a particular input port of the IP are stored contiguously in the memory. If this is not the case, as for instance for interleaved data in stereo signal processing, and if we still want to use burst access to memory, the interface must merge the memory layout organisation with the pattern information to program the controller. We think that this is very difficult to do in a generic way, hence we propose to generate a communication pattern mechanism interface for a fixed memory layout organisation of each stream, the most common case being the in-order data layout organisation.

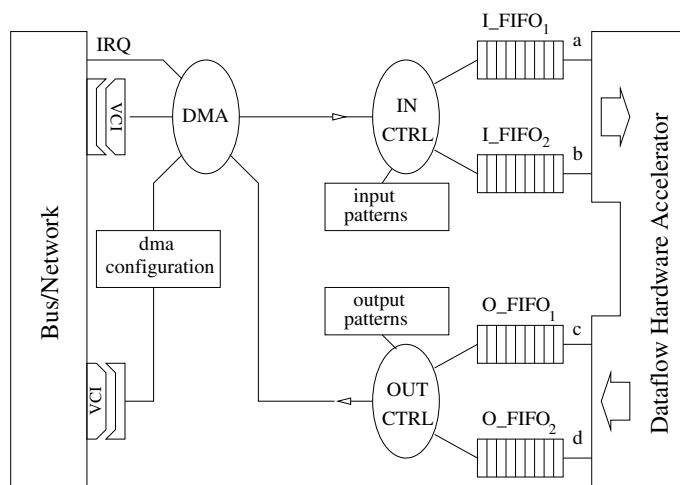

Figure 5. Hardware DMA interface implementation using a single data port for the Data-flow hardware accelerator of Fig. 3.

4. Experiments: Cycle Accurate SoC Simulation

Performance results for this particular kind of experiments are very dependent on some target architecture characteristics as for instance the behaviour of the caches. It is now well known that cache behaviour and network congestion are very difficult to predict, hence the only way to validate our interface mechanism is to perform a cycle accurate simulation of the whole system. We have performed these simulations with the SocLib (<http://soclib.lip6.fr/>) environment and measured the performances obtained with the three main interface modes presented in figure 1, we have also measured the impact of the burst size on the communication performances. The description of the experimental setting is performed in section 4.1, the results are analysed in section 4.2.

4.1. Target Platform And Design Methodology

We have chosen to execute a classical audio signal processing application that processes stereo audio files and proposes various simple filters like LP's tick removal. As we mentioned before, we are interested in non-interleaved streams. Writing an interleaved version of the interface would not be very difficult and would only require a modification of the input and output controllers used within the interface. We have added an 8 tap FIR filter, a simple convolution with 8 multiplication and 8 additions. We have provided a SystemC module implementing a data flow hardware accelerator for this filter. The target platform that we want to simulate is composed of a processor, a memory, the hardware accelerator connected on a communication medium (see right of Fig. 6).

Simulation of the SoC platform was done in SystemC using the SocLib environment. The main component of SocLib is currently a set of SystemC simulation models for common IPs (MIPS processor, RAM, NoC, busses, DMA). All these simulation models use VCI interconnection standard [1]. These simulation models are publicly available and there exists synthesizable RTL versions of the IPs that can be used for the final design. The hardware accelerator was synthesised with MMAlpha [11]. MMAlpha is a toolbox for designing regular parallel architectures (systolic like) from recurrence equation specifications expressed in the Alpha language. It is one of the only existing tools that really automates the refinement of a software specification down to RTL description within the same language: Alpha. We have developed a translator from AlpHard (hardware description language, subset of Alpha) to SystemC [10]. We wrote by hand a SystemC version of the generic interface presented in this paper and we generated from MMAlpha the configuration of the controller and the software driver for different parameters of the experiments (size of the burst, different types of interface) etc.

Providing a complete refinement methodology using high level synthesis from a bulk software specification is not easy, we explain here precisely what we did from the original C-code, it is illustrated in Fig. 6. We have extracted from the C-code a function (referred as `filter.c`) performing the filter, and translated it in Alpha by hand (`filter.alpha`). Driven by the user, MMAlpha will refine this specification down to a hardware description specification in the Alpha language (referred as AlpHard format). At any step of the refinement, MMAlpha can generate C-code for simulation. The filter manually translated in Alpha was validated by replacing the original `filter.c` function by the C code generated from the `filter.alpha` by MMAlpha and testing resulting execution against original program. Then MMAlpha generated a systolic version of the filter from which we generated a SystemC simulation model (`filter.cpp`), and a SystemC file for configuring the hardware interface and the software driver (`driver.c`). The software driver replaced the original `filter.c` in the program before its compilation to the MIPS processor. In the particular instance of the SoC represented in figure 6, there is no DMA, this driver explicitly performed all the communications between the memory and the hardware accelerator as did the driver represented on the right of Fig. 4. Hence, on Fig. 6, the box labelled **Filter** is composed of the generic interface plus the SystemC files generated by MMAlpha: interface configuration and `filter.cpp`.

The hardware components of the platform are: a MIPS R3000 processor (with its associated data and instruction cache) also referred as the CPU, a standard memory, a component used for displaying output (referred as TTY) and the a specific hardware accelerator generated with MMAlpha including the interface. All these components are connected via VCI ports to a simple network (internal architecture of this network is not precisely simulated, only the latency and bandwidth can be parameterised). All these components are *memory mapped*, i.e. the MIPS has access to the input and output ports of the hardware accelerator as two particular memory locations. The software running on the MIPS, in addition to bootstrapping information, is composed of the C program cross-compiled with GCC to a MIPS target.

We have written three SoC platforms to simulate the three types of interface illustrated in Fig. 1. In the first platform (Fig. 1-a), the CPU drives all communications: in order to send a data to the accelerator, the software driver running on the MIPS must read the data in the memory and write it

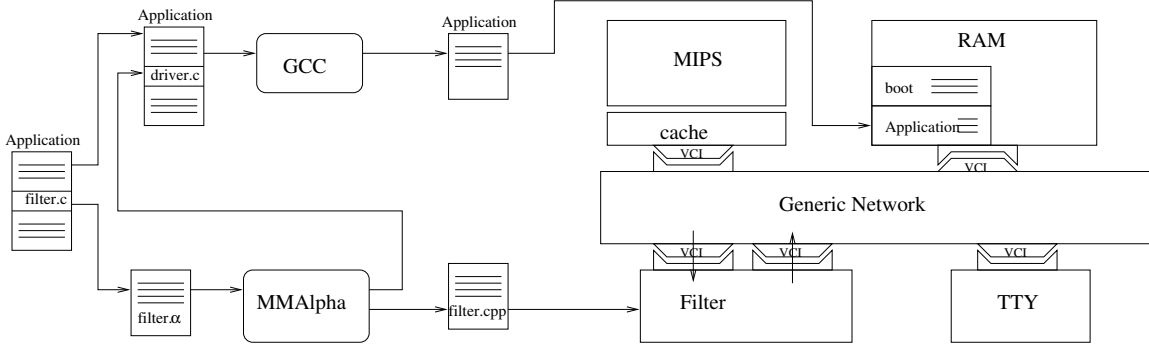

Figure 6. The SoC simulated and the global design methodology. Square boxes represent SystemC models of IPs.

at the memory location of the accelerator I/O ports, this is illustrated by arrows 1 and 2 on Fig. 1-a, this is also what performs the `SEND` macro of Fig. 4. In this version, the accelerator contains two slave ports: one for input, one for output.

The second platform uses an external DMA that can outperform the CPU by using longer communication burst on the interconnect, it is represented on Fig. 1-b. If the DMA is parameterised to perform one burst, the behaviour of a `SEND` is the following: the MIPS configures the DMA, then the DMA reads the data in memory and writes it to the hardware accelerator (in burst mode, arrow 1, 2 and 3 of Fig. 1-b), then it raises an interruption to indicate to the MIPS that the communication occurred. This interruption is a major problem because it takes approximately 380 cycles to be handled by the MIPS. In order to minimise the impact of the interruption, we have authorised the scatter-gather scheme for the DMA: the DMA can store more than one burst communication configuration, the number of configuration stored is a parameter of our experiment, this is a classical improvement of DMA engines. We are promoting another modification of the DMA: because of the very regular nature of our communications (transmitting continuous streams), the configuration of the DMA is always the same up to the starting address of the data which is incremented regularly. If we could, for instance implement the loop present on the driver of Fig. 4 *inside* the DMA, we would gain a lot of interruption handling ($N/20$ in the example of Fig. 4). This can be easily done by providing an additional register in the DMA which indicates how many times the configuration stored on the DMA must be executed before waking up the CPU. We have implemented this improvement in the simulation model of our DMA.

The third platform is simply obtained by putting the DMA *inside* the hardware accelerator. This is a natural improvement, as shown in Fig. 5, it immediately divides the number of communications by two. In this version, the hardware accelerator contains one slave port for configuration by the MIPS and one master port for initiating communications with the memory (Fig. 1-c).

4.2. Experimental Results

In this section we only measured the portion of code composed of the original `filter.c`. Some performance results are presented in table 1, in this table and in the rest of the section, the term CPU refers to the first platform (Fig 1-a), the term *external* DMA refers to the second platform (Fig 1-b) and the the term *internal* DMA refers to the third platform (Fig 1-c). This table shows an average simulation speed of 50 000 cycles per second, there is no major difference in simulation speed between the three platforms, the only difference is for the *loop enable* DMA platform that is slightly slower due to the activity increase that has to be simulated. We can immediately see the improvement of the internal *loop enable* DMA platform: a throughput of 254 000 samples for 600 000 cycles is obtained. The theoretical maximum throughput that can be obtained is 300 000 samples

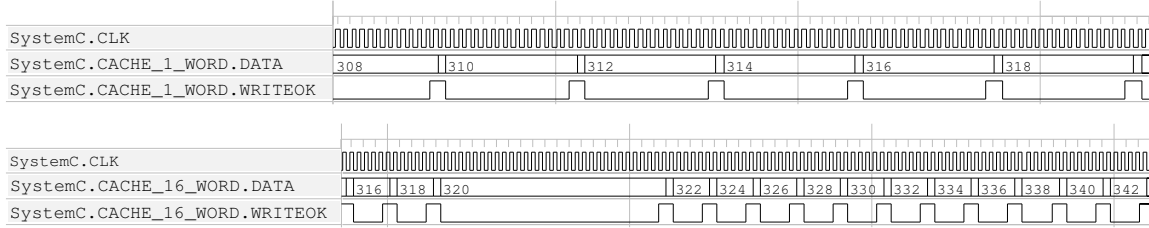

Figure 7. Effect of different size of data cache lines (1 bus word and 16 bus word) on the arrival of data to the IP.

for 600 000 cycles, indeed each sample is 16 bits wide, there are two sample stream which must be at least read once from the memory and write once to the memory, hence with a memory answering in one clock cycle and a bus width of 32 bits we cannot compute more than 300 000 samples for 600 000 cycles. The internal *loop enable* DMA version is nearly optimal. There is no major difference between the CPU version and the DMA version because the improvement provided by the burst of the DMA is counter-balanced by the overhead of the DMA interruptions.

	CPU	ext. DMA	int. DMA	int. DMA w/ loop
complete simulation time (seconds)	10.91	12.82	10.91	18.26
complete simulation cycles	600000	600000	600000	600000
simulation speed (cycles/seconds)	54995.5	46802	54995.5	32858.8
hardware pipeline throughput (samples)	16861	10561	9601	254041

Table 1. Performances obtained from the complete SoC simulation for burst size of 30 samples and different hardware configuration

For the CPU driven platform the cache size has a strong effect on performance. For instance, in Fig. 7, we have shown the influence of cache line size on the frequency at which data could arrive to the IP. The use of cache line of 16 bus word increases the throughput and the effect of a cache miss can be clearly visualised. With cache line reduced to one bus word, the data arrive regularly but slower. On the other hand it can be shown that cache size does not influence performances on this application as cache are direct-mapped. The behavior shown in Fig. 7 clearly indicate that efficient handling of burst mode through a DMA module is a crucial issue to obtain an efficient use of the hardware accelerator. However, as it can be seen in table 1, performance for the DMA engine are counterbalanced by the interrupt acknowledge mechanism that reduces the gain obtained with burst communications for small burst sizes. This tradeoff quickly turns in favour of the DMA platform for burst sizes larger than 70 bus words on our architecture. As soon as the burst sizes counterbalance the interrupt latency the DMA platform is more efficient than CPU driven I/O as it can be seen on figure Fig. 8 (*ext. dma*).

Using an external DMA module allows more efficient burst communications over the interconnect but still requires 4 transfers for each samples. The third architecture uses an internal DMA that has been implemented directly in the interface. This DMA engine allows the interface to directly access the memory to fetch its input samples and to write the results back to the memory in only 2 accesses to the interconnect, reducing the number of data transfers by a factor 2 compared to the external DMA platform. Hardware accelerator throughput is not changed by using an internal DMA for small burst sizes as the main bottleneck is still the transfer of DMA configurations and interrupt handling. Hardware throughput for internal DMA is shown on figure Fig. 8 (*int. dma(1)*).

The next architecture modification we have made is to use a scatter/gather enabled DMA engine that can store several successive transfer configurations. This list reduces the number of interrupt that are generated by the DMA. For instance, a list size of n configurations allows to reduce by a

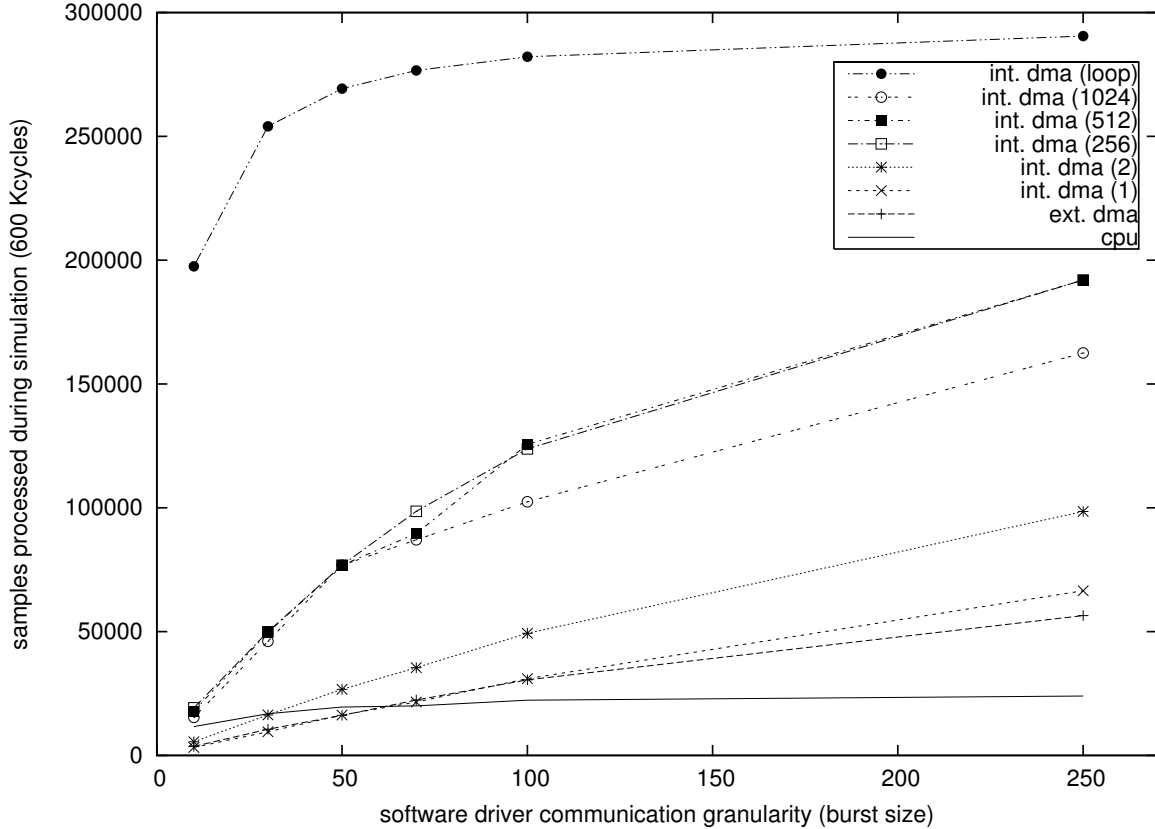

Figure 8. Hardware accelerator throughput according to different burst length and CPU or DMA communication mechanism

factor n the number of interrupt acknowledge handled by the CPU. Performance improvements can be seen on figure Fig. 8 for several list size varying between 1 and 1024 configurations (`int. dma(1` -- `1024)`). Even when using big list sizes, performances are still not at the maximum throughput, the CPU still has to perform configuration transfers using the bus. The more configuration the DMA can store, the more transfers have to be done between two successive run of the accelerator. These inactivity periods occurring between burst mode computation phases introduce some extra latency that freezes the hardware pipeline during reconfiguration and have to be taken into account for real-time processing that have strict timing or jitter constraints on the data streams. Furthermore, the performance improvement is limited by the configuration transfers and we can observe a maximum performance between 256 and 512 configuration list sizes followed by a performance decrease for bigger lists. This performance decrease comes from the latency introduced by long configurations that cannot be fully completed during the 600 000 cycles of the simulation.

The last architecture we simulated overcomes the configuration problem by storing and transferring the *complete* configuration to the internal DMA using a compact representation. This configuration represents the *phases* and *motifs* discussed in section 3. The *loop enable* DMA that we use in the architecture can perform the complete processing transfer without requiring interrupt for configuration transfers. This communication mode is close to the maximum theoretical throughput even for small burst sizes and is thus limited only by the interconnect bandwidth and memory performances. Furthermore, this high throughput is obtained for small burst sizes and allows to keep latency and jitter to a minimum compared to similar performances obtained with other solutions using big configuration lists. The performance results of Fig.8 clearly demonstrates that the loop enable DMA is mandatory to reach interesting performances with a data-flow IPs on a SoC.

5. Related work

Many recent works present SoC simulation environments [18, 4, 14]. These approaches do not have an Open Source policy as the one of SocLib, their main concern is the acceleration of the simulation at various level of precision: transaction level or cycle accurate level. These works do not propose generic interface mechanism for IPs. Some attempt have been made to abstract communication behaviour at high level [6] or at low level [26, 25, 2], but none of these approaches use the assumption that the IP are in the data-flow model hence they propose solutions which are not optimised for stream processing.

Many of the interesting results in this field are based on the work of the Ptolemy project [17] and especially the introduction of various computation models for data-flow IPs: process network [16] or SDF [27, 15]. An interesting theory has been developed for multi-rate IP-based systems [12], but the problem solved is the interconnection between several data-flow IP while we specifically target a single data-flow IP controlled by a host. The work presented here has its roots in the research on the MMAAlpha system [8, 9], a very similar problem was studied by Park and Diniz [19, 20] leading to the design of a generic interface that can be parameterised to connect to different data-flow IP with some constraints on the IPs. This approach does not assume that communications are known statically and propose a run-time resolution to solve conflicting access to the bus.

Several high level design tools are now clearly identified either as research prototypes or industrial products [11, 5, 24, 13, 16, 3], each of these tools have implemented ad-hoc communication protocol between the generated data-flow IP and the host. The Pico [24] tool and the Paro tool [3] have in house interface mechanisms with dedicated solution for the problem exposed here. We expect our model to be usable at least by MMAAlpha and Gaut [5].

6 Conclusion

In this paper we have delimited a class of architecture that is subject to high throughput requirement and restricted enough to allow an interface mechanism which is generic and efficient. The notion of phase, motif and pattern can be defined for many data flow IP and are particularly useful for high level design tools that can use them to generate hardware and software interfaces together with the IP.

The cycle accurate simulation environment that we use is much more accurate than theoretical estimation of throughput because cache behaviour and interruption handling are very difficult to predict. We have highlighted an important issue: a very important improvement in the throughput between the memory and the IP can be obtained with a slightly optimised version of scatter-gather DMA that we called *loop-enable* DMA. We have shown that the hardware/software of the interface can be generated automatically together with the IP and quasi-optimal communication throughput can be reached.

References

- [1] VSI Alliance. Virtual component interface standard (OCB specification 2, version 1.0), 2000.
- [2] N. Banerjee, P. Vellanki, and K.S. Chatha. A power and performance model for network-on-chip architectures. In *Design, Automation and Test in Europe Conference (DATE)*, Paris, France, March 2004.
- [3] M. Bednara and J. Teich. Automatic synthesis of FPGA processor arrays from loop algorithms. *Journal of Supercomputing*, 26:149–165, 2003.

- [4] M. Bolado, H. Posadas, J. Castillo¹, P. Huerta¹, P. Sánchez¹, C. Sánchez, H. Fouren, and F. Blasco. Platform based on open-source cores for industrial applications. In *Design, Automation and Test in Europe Conference (DATE)*, Paris, France, March 2004.
- [5] E. Casseau, C. Jego, and E. Martin. Architectural synthesis of digital processing applications dedicated to submicron technologies. In *IEEE International Conference on Electronics, Circuits, and Systems (ICECS 01)*, pages 533–536, 2001.
- [6] V. Chandras, A. Xu, H. Schmit, and L. Pileggi. An interconnect channel design methodology for high performance integrated circuits. In *Design, Automation and Test in Europe Conference (DATE)*, Paris, France, March 2004.
- [7] Alain Darte, Steven Derrien, and Tanguy Risset. Hardware/software interface for multi-dimensional processor arrays. In *IEEE International Conference on Application-specific Systems, Architectures and Processors (ASAP)*. IEEE Computer Society Press, 2005.
- [8] S. Derrien, A. C. Guillou, P. Quinton, T. Risset, and C. Wagner. Automatic synthesis of efficient interfaces for compiled regular architectures. In *Internationnal Samos Workshop on Systems, Architectures, Modeling and Simulation (Samos)*, Samos, Grece, July 2002.
- [9] S. Derrien and T. Risset. Interfacing compiled FPGA programs: the MMAAlpha approach. In A. Arabnia, editor, *PDPTA2000: Second International Workshop on Engineering of Reconfigurable Hardware/Software Objects*. CSREA Press, June 2000.
- [10] A. Fraboulet, T. Risset, and Antoine Scherrer. Cycle accurate simulation model generation for SoC prototyping. Technical Report 2004-18, LIP, ENS-Lyon, May 2004.
- [11] A.-C. Guillou, P. Quinton, T. Risset, C. Wagner, and D. Massicotte. High level design of digital filters in mobile communications. Technical Report 1405, Irisa, June 2001.
- [12] J. Horstmannshoff, T. Grotker, and H. Meyr. Mapping multirate dataflow to complex RT level hardware models. In *IEEE International Conference on Application-Specific Array Processors (ASAP)*, pages 283–293., 1997.
- [13] B. Hounsell and R. Taylor. Co-processor synthesis a new methodology for embedded software acceleration. In *Design, Automation and Test in Europe Conference and Exhibition (DATE Designers' Forum)*, Paris, France, March 2004.
- [14] H.A. Jang, M. Kang, M.J. Lee, K. Chae, K. Lee, and K. Shim. High-level system modeling and architecture exploration with systemc on a network SoC: S3C2510 case study. In *Design, Automation and Test in Europe Conference (DATE)*, Paris, France, March 2004.
- [15] Hyunuk Jung, Kangnyoung Lee, and Soonhoi Ha. Efficient hardware controller synthesis for synchronous dataflow graph in system level design. In *International Symposium on System Synthesis (ISSS)*, pages 79–84, 2000.
- [16] B. Kienhuis, E. Rijpkema, and E.F. Deprettere. Compaan: Deriving process networks from matlab for embedded signal processing architectures. In *8th International Workshop on Hardware/Software Codesign (CODES)*, 2000.
- [17] E.A. Lee et al. Overview of the Ptolemy project. Technical Report UCB/ERL No. M99/37, University of California, Berkeley, july 1999.
- [18] M. Loghiy, F. Angiolini, D. Bertozzi, L. Benini, and R. Zafalon. Analyzing on-chip communication in a MPSoC environment. In *Design, Automation and Test in Europe Conference (DATE)*, Paris, France, March 2004.
- [19] Joonseok Park and Pedro C. Diniz. Synthesis of pipelined memory access controllers for streamed data applications on FPGA-based computing engines. In *International Symposium on System Synthesis (ISSS)*, pages 221–226, 2001.

- [20] Joonseok Park and Pedro C. Diniz. Synthesis and estimation of memory interfaces for FPGA-based reconfigurable computing engines. In *International Symposium on FPGA Custom Computing Machines*, 2003.
- [21] D. Gracia Pérez, G. Mouchard, and O. Temam. A new optimized implementation of the systemC engine using acyclic scheduling. In *Design, Automation and Test in Europe Conference and Exhibition (DATE Designers' Forum)*, Paris, France, March 2004.
- [22] Frédéric Pétrot, Denis Hommais, and Alain Greiner. A simulation environment for core based embedded systems. In *Annual Simulation Symposium*, pages 86–91, Atlanta, GA, U.S.A, April 1997.
- [23] P. Quinton, S. V. Rajopadhye, and T. Risset. On manipulating Z-polyhedra using a canonical representation. *Parallel Processing Letters*, 7(2):181–194, June 1997.
- [24] R. Schreiber et al. High-Level Synthesis of Non Programmable Hardware Accelerators. In *IEEE International Conference on Application-specific Systems, Architectures and Processors (ASAP)*, Boston, July 2000.
- [25] C. Shin, Y. Kim, E. Chung, K. Choi J. Kong, and S. Eo. Fast exploration of parameterized bus architecture for communication-centric SoC design. In *Design, Automation and Test in Europe Conference (DATE)*, Paris, France, March 2004.
- [26] V. D. Silva, S. Ramesh, and A. Sowmya. Synchronous protocol automata: A framework for modelling and verification of SoC communication architectures. In *Design, Automation and Test in Europe Conference (DATE)*, Paris, France, March 2004.
- [27] M.C. Williamson. *Synthesis of parallel hardware implementations from synchronous dataflow graph specifications*. PhD thesis, University of California, Berkeley, CA, 1998.