

Observing and Controlling Plants using their Delayed and Sampled Outputs

A. Chamroo¹, A. Seuret², C. Vasseur¹, J.-P. Richard² and H.P. Wang¹

Laboratoire d'Automatique, Génie Informatique & Signal, LAGIS (UMR CNRS 8146)

¹Université des Sciences & Technologies de Lille, USTL (Cité Scientifique)

59655 Villeneuve d'Ascq, FRANCE

Phone: +33 3 20 43 48 76, Fax: +33 3 20 43 65 67,

E-mails: chamroo@i3d.univ-lille1.fr, christian.vasseur@univ-lille1.fr, haoping.wang@ed.univ-lille1.fr

²École Centrale de Lille

BP 48, 59651 Villeneuve d'Ascq Cedex, France

Phone: +33 3 20 67 60 32, Fax: +33 3 20 33 54 99, E-mails: seuret.alexandre@ec-lille.fr, jean-pierre.richard@ec-lille.fr

Abstract - This article deals with linear plants whose outputs are not available directly, but only via digital sensors which deliver them in a delayed and sampled format. First, we reconstitute the plant's state by using a Lyapunov-Krasovskii based observer. A sampled tracking control strategy is then proposed by combining the observer with a particular controller that belongs to a class of piecewise continuous systems. Computer simulation examples are presented so as to enhance the theoretical aspect. The method shows reliability and robustness against slight time-variations of the plant's parameters.

Keywords: Lyapunov-Krasovskii functional, LMI, sampled tracking, delayed output, piecewise continuous systems

I. INTRODUCTION

The aim of this research work is to develop a control strategy that enables sampled tracking on linear plants in cases where the only available feedback is the plant's delayed and sampled output vector. This is often the case when we deal with control architectures that make use of digital calculators and digital sensors that are time consuming in what concerns step calculations.

Assuming that the linear plant is perfectly identified, an observer is used so as to reconstitute the current state by using the delayed (and sampled) output. This estimated state is necessary for the chosen controller. For the discrete-time implementation, the data-sampling effect has to be taken into account. Following the lines of [FRI, 04], [YU, 04] and [SEU, 05], we consider that it produces an additional, variable delay $t-t_k$, where t_k is the most recent k^{th} sampling instant. Generally, due to the computer architecture and operating system, the sampling may be aperiodic, *i.e.* there is no exact period T such that $t_k = kT$. So, we assume that a maximum sampling interval T is known, so that $0 \leq t_{k+1} - t_k \leq T$ holds. The global delay resulting from the computation-plus-sampling phenomena will be denoted by $\delta = t - t_k$, and it can be seen that the limit case $d\delta/dt = 1$, which represents the worse situation in the study of time-delay systems, occurs almost everywhere. The aim is to generate robust, stable and continuous-time observation with respect to the sampling period or parameters uncertainties. A Luenberger observer for known time-varying delay is proposed using

this sampling modelization. The stability results are presented using Linear Matrix Inequality (LMI). Its purpose is to estimate the current state as fast as possible.

In order to achieve sampled tracking, we propose a control unit based on [KON, 01], [KON, 02] and [KON, 03] that establishes a class of control systems whose evolution is described by exogenous switching of their internal state. The chronology of the switching is defined by a set of sampling instants $S = \{t_k, k = 0, 1, 2, \dots\}$ called "switching instants". These controllers that extend the notion of sampled control commands [KAB, 87] are referred to as piecewise continuous systems (PCS). In this approach, the control input of the plant is defined from two input spaces: the first space U^r allows control between switching instants, while the second input space V^s enables control at the switching instants. Referring to the classification of [TIT, 98], this class of control systems has hybrid properties and extends the concept of compound control realized by [LAU, 72] and [VAS, 72]. According to Branicky's taxonomy of hybrid systems [BRA, 94], these control units are characterized by autonomous switchings and controlled impulses.

It is well established in [KON, 03] that the use of PCS controllers enables sampled tracking on linear plants by undertaking a state feedback. In our case, we make use of the aforementioned observer to feed the PCS controller with an estimate of the state.

In this paper, we start by defining the particular nature of the output signal considered for feedback. A block diagram of the whole closed loop structure is then given in section III. The observer and controller are then described in the following sections. The reader can find at the end of the paper a typical visual control example raising a delayed and sampled output problem while controlling a mobile cart by camera.

II. THE PARTICULAR SENSOR OUTPUT

The plant we consider in our study is a usual linear n^{th} order system that we represent by its state and output equations as follows:

$$\dot{x}(t) = A.x(t) + B.u(t), \quad (1a)$$

$$y(t) = C.x(t), \quad (1b)$$

with $A \in \mathfrak{R}^{n \times n}$, $B \in \mathfrak{R}^{n \times r}$ and $C \in \mathfrak{R}^{m \times n}$ being the real, known characteristic matrix of the system, and $x(t) \in \Sigma^n$, $u(t) \in U^r$ and $y(t) \in Y^m$ representing respectively the state, the input and the output of the plant. We assume that the pair (A, C) is observable.

In our case, we consider that neither the state $x(t)$, nor the output $y(t)$ of the plant is available. The only data we can access becomes from a digital sensor that delivers the output y in a sampled and delayed format. The sampling period of the sensor being t_e and its associated delay being D , we define the sensor data as such:

$$z(t) = y^*(t - D). \quad (1c)$$

In (1c), $(*)$ represents a sampling with a known maximal period t_e . In our study, we assume that D is bounded with known upper and lower bounds.

An illustrating example can be the case where processed data accessed from a digital camera constitute the output $z(t)$ of a “visual” sensor. In that case, the t_e sampling period corresponds to the delivery of image information where t_e represents the time for an image shooting. Moreover, the time delay D represents the time necessary for image processing. Usually, in such an example, the delay is a multiple of the sampling period, so that it can be expressed by $D = N.t_e$ ($N \in \mathbb{Z}$). This means actually that N snapshots are necessary to obtain the required data.

The whole statement of this section is summarized in Fig. 1, with $N = 4$ in the example considered in section VI.

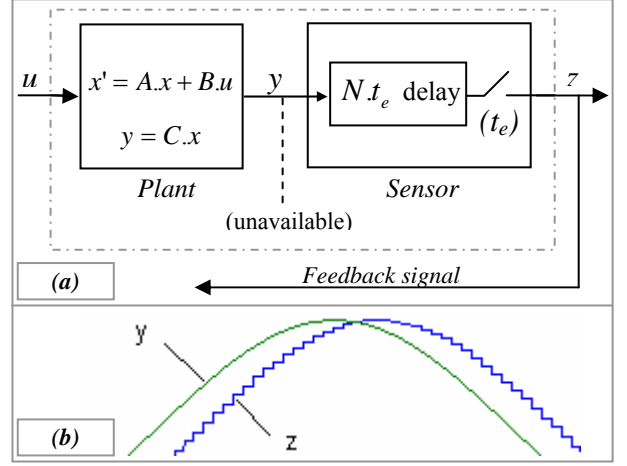

Fig. 1a. The plant-sensor entity,

Fig. 1b. Output signals for $N=4$.

III. PRINCIPLE

The aim is to be able to perform sample tracking of a given state trajectory by the plant's unavailable state. This is ensured by the PCS controller that necessitates the full state measurement given by the observer. The closed loop structure is given in Fig. 2 below.

IV. OBSERVER DESIGN

Using the sampling representation proposed in the introduction, the sensor's output can be written as $z(t) = y(t - \delta(t))$, where $\delta(t) = D + t - t_k$. Then a continuous-time, delayed Luenberger observer can be considered:

$$\dot{\hat{x}}(t) = A.\hat{x}(t) + B.u(t) - L.(y(t - \delta(t)) - \hat{y}(t - \delta(t))), \quad (2a)$$

$$\hat{y}(t) = C.\hat{x}(t). \quad (2b)$$

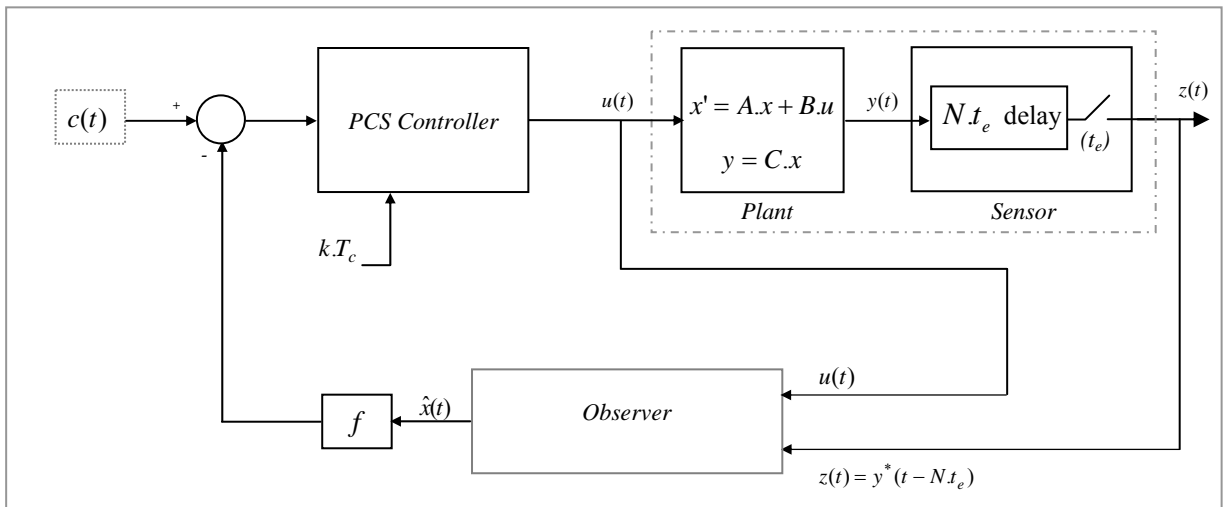

Fig. 2. Block diagram of the whole closed loop structure using delayed output feedback

Since the pair (A, C) is observable, it is possible to determine a linear gain L such that the observer exponentially converges to the real system in the non-delayed case. The next theorem allows us to design another L so that the observer state $\hat{x}(t)$ converges sufficiently fast (with a guaranteed exponential rate α) to the real system state $x(t)$ despite a variable delay δ on the plant's output. The error vector is defined as $e(t) = x(t) - \hat{x}(t)$. From (1) and (2), this error is ruled by:

$$e'(t) = Ae(t) + LCe(t - \delta(t)) \quad (3)$$

Theorem 1: Suppose that, for some positive scalars α and ε , there exists a $n \times n$ positive matrix P_1 and $n \times n$ matrices $P, S, Y_1, Y_2, Z_1, Z_2, Z_3, R, R_a$ and a matrix W with appropriate dimensions such that the following LMI conditions are satisfied for $j=1,2$:

$$\begin{pmatrix} \psi & \begin{bmatrix} \beta_i WC - Y_1^T \\ \varepsilon \beta_i WC - Y_2^T \end{bmatrix} & \mu \beta_i \begin{bmatrix} WC \\ \varepsilon WC \end{bmatrix} \\ (\&) & -S & 0 \\ (\&) & (\&) & -\mu R_a \end{pmatrix} < 0 \quad (4a)$$

and

$$\begin{pmatrix} R & Y_1 & Y_2 \\ (\&) & Z_1 & Z_2 \\ (\&) & (\&) & Z_3 \end{pmatrix} < 0 \quad (4b)$$

where the symbol $(\&)$ in a matrix represents a symmetrical entry, where $\beta_1 = e^{\alpha(\delta-\mu)}$, $\beta_2 = e^{\alpha(\delta+\mu)}$ and the symmetric matrix ψ is given by:

$$\psi = \begin{bmatrix} \psi_{11} & \psi_{21} \\ \psi_{21}^T & \psi_{22} \end{bmatrix}$$

$$\psi_{11} = P^T(A + \alpha I) + (A + \alpha I)^T P + S + \delta Z_1 + Y_1 + Y_1^T, \quad (5a)$$

$$\psi_{12} = P_1 - P + \varepsilon P^T(A + \alpha I)^T + \delta Z_2 + Y_2, \quad (5b)$$

$$\psi_{22} = -\varepsilon(P + P^T) + \delta Z_3 + 2\mu R_a. \quad (5c)$$

In the previous theorem, the delay $\delta(t)$ and then, δ and μ , are imposed by the maximum the sampling period and the computation delay. The greater α corresponds to a faster the stabilization. Thus, the objective is to tune ε to maximize α .

The proof is based on Lyapunov-Krasovskii techniques and descriptor representation detailed in [SEU, 06].

V. PCS CONTROL COMMAND

A. Principle

The principle of PCS control is to build an associated PCS system whose output constitutes the input of the plant. Note that some of the variables of the controller are c -indexed so as to be distinguished from those of the observer. According to [KON, 03], we make use of a PCS system to define a particular PCS controller whose behavior can be summarized as follows:

(i) The state of the PCS controller is switched to forced values at regular intervals of period T_c , with $T_c < t_e$ such that $t_e = qT_c$, with $q \in \mathfrak{R}$ and $q \geq 1$. The corresponding switching set is represented by $S = \{kT_c, k = 0, 1, 2, \dots\}$.

(ii) The equations describing the behavior of the controller are:

$$\lambda'(t) = \alpha_c \lambda(t), \forall t \in]kT_c, (k+1)T_c], \quad (6a)$$

$$\lambda(kT_c^+) = \delta_c \psi_c(kT_c), \forall k = 0, 1, 2, \dots, \quad (6b)$$

$$w(t) = \gamma_c \lambda(t), \forall t. \quad (6c)$$

Equation (6a) describes the continuous evolution of the controller's state $\lambda(t) \in \Sigma^{\hat{n}}$ upon $]kT_c, (k+1)T_c]$, $\alpha_c \in \mathfrak{R}^{\hat{n} \times \hat{n}}$ being the state matrix of the controller. The only parameter that defines the behavior of the controller's state in this interval of time is α_c which can take an arbitrary value. Usually, it is fixed such that the PCS is stable between switching instants.

Equation (6b) defines the controller's state at switching instants, by means of a bounded discrete input $\psi_c \in V^s$, and according to the linear relationship characterized by the matrix $\delta_c \in \mathfrak{R}^{\hat{n} \times s}$.

Equation (6c) is the output equation of the controller, characterized by the full rank matrix $\gamma_c \in \mathfrak{R}^{\hat{m} \times \hat{n}}$. The output $w(t) \in Y^{\hat{m}}$ constitutes the input command to be fed to the plant.

Fig. 3a gives the realization diagram of a PCS controller and Fig. 3b shows its state's evolution.

It is shown in [KON, 03] that if the state of the plant is available, it is possible to define $\psi_c(t)$ and δ_c so as to achieve discrete tracking of a $c(t)$ state trajectory by the plant's state $x(t)$ at each switching instant and with one sampling period delay: $x((k+1)T_c) = c(kT_c)$, $\forall k = 0, 1, 2, \dots$

Note that from now on, the discrete values of every function will be considered as being sampled at T_c period and to simplify the notations, any time function $f(t)$ at a given kT_c instant will be written as $f(kT_c) = f_k$

$\forall k = 0, 1, 2, \dots$. Moreover, dealing with PCS gives rise to discontinuous signals. Thus, if any signal $f(t)$ is discontinuous, we shall consider the right value at the discontinuity since the switching at each kT_c imply consequences occurring at every kT_c^+ . However, for simplification sake, the notation f_k will be used, instead of the strict one: $f_k^+ = f(kT_c^+)$.

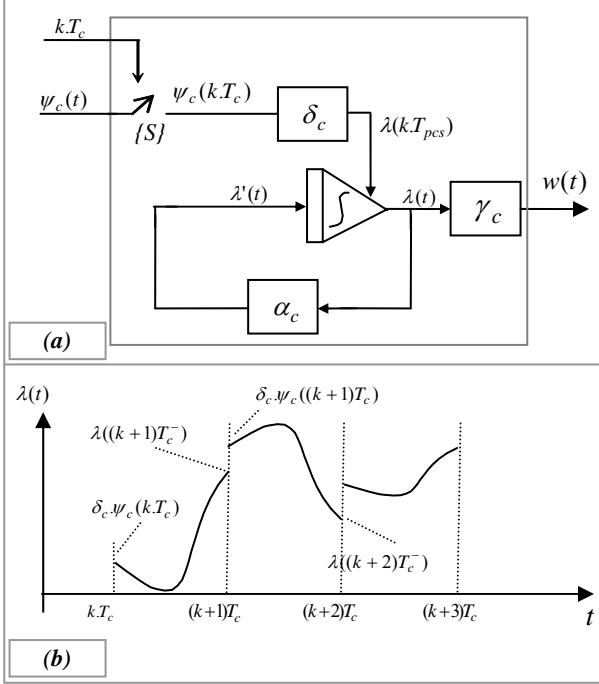

Fig. 3a. Realization diagram,
Fig. 3b. State evolution of a PCS controller

B. State Feedback PCS Controller

Let's design a PCS controller meant to perform sampled tracking in the case where the state $x(t)$ of a linear plant (as in (1a)) is available. The aim is to define its matrix $\psi_c(t)$ and input δ_c to achieve $x_{k+1} = c_k$. The controller's output is linked to the plant's input, thus $u(t) = w(t)$. Then, we only have to rely on the observer defined above to make use of $\hat{x}(t)$ instead of $x(t)$ as in Fig. 2. In this case, the behavior of the closed loop system can be given by the following equation set:

$$x'(t) = A.x(t) + B.u(t), \forall t, \quad (7a)$$

$$\lambda'(t) = \alpha_c.\lambda(t), \forall t \in]kT_c, (k+1)T_c], \quad (7b)$$

$$u(t) = \gamma_c.\lambda(t), \forall t, \quad (7c)$$

$$\lambda_k = \delta_c.\psi_{c_k}, \forall k = 0, 1, 2, \dots \quad (7d)$$

By integration, the first three equations allow us to write in a sampled format, the next step value x_{k+1} of the state as a function of its previous one x_k :

$$x_{k+1} = f.x_k + M.\lambda_k, \quad (8)$$

$$\text{with } f = e^{AT_c} \text{ and } M = f.\int_0^{T_c} e^{-A\tau} B.\gamma_c.e^{\alpha_c\tau} d\tau.$$

In order to realize the discrete tracking which is defined above, we only have to fix down the tracking condition which is $x_{k+1} = c_k$, where $c(t)$ is the desired state trajectory. Thus, from (8) we have:

$$\lambda_k = M^{-1}\{c_k - f.x_k\} \quad (9)$$

Equation (9) gives the switching value of the controller's state, under the condition that M^{-1} exists [KON, 03]. Hence, in this case, we are able to define the PCS controller with:

$$\delta = M^{-1} \text{ and } \psi(t) = c(t) - f.x(t), \\ \alpha \text{ and } \gamma \text{ chosen arbitrarily.}$$

VI. COMPUTER SIMULATION EXAMPLE

In view of validating our method we have simulated, by means of Matlab[®]/Simulink[®], the behavior of the whole closed loop structure shown in Fig. 2. This computer simulation reflects the control of a real system which is described below. As shown in Fig. 4, this system consists of the visual position control of a moving cart.

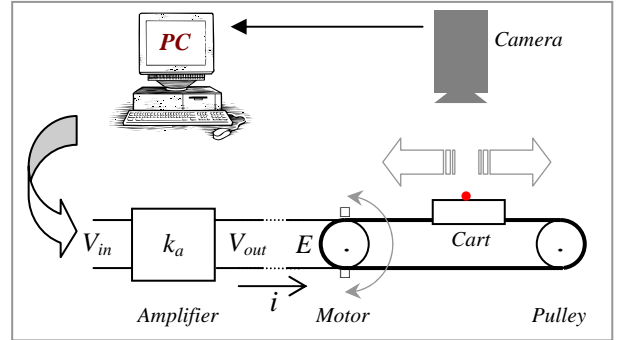

Fig. 4. Visual control

A. The Plant

The plant which is considered here is a cart that moves along a horizontal and straight line segment. The cart is powered by an electric motor by means of a notched belt. The plant's state is composed of the real position and speed of the cart, while its output is given by the real position only:

$$x = \begin{bmatrix} x_1 \\ x_2 \end{bmatrix} = \begin{bmatrix} \text{real position} \\ \text{real speed} \end{bmatrix}, y = x_1$$

The motor is of a brushless type. It is driven in +/-10V by a dSpace[®] computer input/output card via a power amplifier. Supplied with 240V (mono), it can offer a nominal couple of 3.0Nm with a power of 200W. Identification with a second order approximation of the ampli-

fier-motor-cart set has shown a time constant of 8.3ms and an overall gain of 2.9m/S/V.

Hence, we assume that the plant can be defined as in (1a) by matrices:

$$A = \begin{bmatrix} 0 & 1 \\ 0 & -120 \end{bmatrix}, B = \begin{bmatrix} 0 \\ 350 \end{bmatrix} \text{ and } C = [1 \ 0]$$

B. The Sensor

The aim of the experiment is to realize a visual position control of the cart. Thus, the sensor is an ‘‘artificial vision’’ system that observes an infrared LED fixed on the cart, as shown in Fig. 4. This vision system is constituted of a motionless digital infrared CCD camera connected to a computer allowing image processing. The camera is positioned above the cart and observes its motion. Thus, after a location operation, the artificial vision system outputs the position of the cart in a t_e -sampled format, with here a delay equal to t_e itself. We thus have in this case:

$$z(t) = x_1^*(t - t_e), \text{ with } (*): \text{ sampling at } t_e.$$

Here, $t_e = 28\text{ms}$. This corresponds actually to image snapshots with a t_e -period reset mode ensuring that image acquisition and processing are carried out inside that period.

C. The Observer

In this particular example, the resolution of the LMI conditions (4a,b) leads to the Luenberger gain :

$$L = \begin{bmatrix} -3.1225 \\ 0.0569 \end{bmatrix}$$

D. The Associated PCS Controller

In order to achieve tracking, the PCS controller uses the estimated state obtained from the observer. The controller is switched at regular intervals with $T_c = 10\text{ms}$ and is defined by:

$$\alpha_c = \begin{bmatrix} -0.1 & 0 \\ 0 & -0.2 \end{bmatrix}, \gamma_c = [1 \ 1]$$

E. The Aim of the Experiment

In the present example, the goal is to be able to realize sampled position tracking of a desired trajectory by the cart. According to our method’s requirement, we have to define a state trajectory, which is here chosen to be:

$$c(t) = \begin{bmatrix} c_1(t) \\ c_2(t) \end{bmatrix} = \begin{bmatrix} a \cdot \sin(\omega t) \\ a \cdot \omega \cdot \cos(\omega t) \end{bmatrix}$$

In this example, $c_2(t)$ is bound to be the derivative of

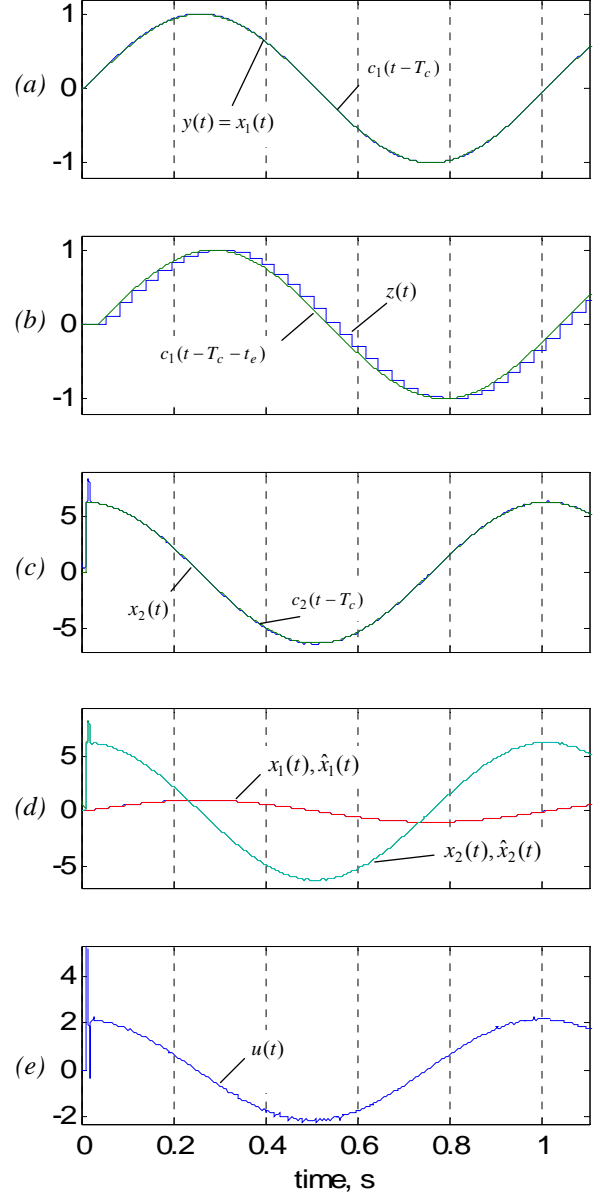

Fig. 5. Tracking ($T_c = 10\text{ms}$, $a = 1$ and $\omega = 2\pi \text{ rad/s}$)

$c_1(t)$, since they represent, respectively, the desired speed and position trajectories.

F. Results Comment

Figs. 5 and 6 illustrate tracking results for the stated example. Note that for comparison sake, the desired trajectory has been delayed appropriately on those figures. The PCS switching period and parameters of the desired trajectory differ so as to express performance in working conditions (Fig. 5) and functioning demonstration in exaggerated ones (Fig. 6).

Fig. 5a shows sampled tracking of $c_1(t)$ by the plant's output $y(t)$ which is here equal to the real cart position $x_1(t)$. Similarly, Fig. 5c shows how the second state variable (speed) reaches its desired trajectory at switching instants.

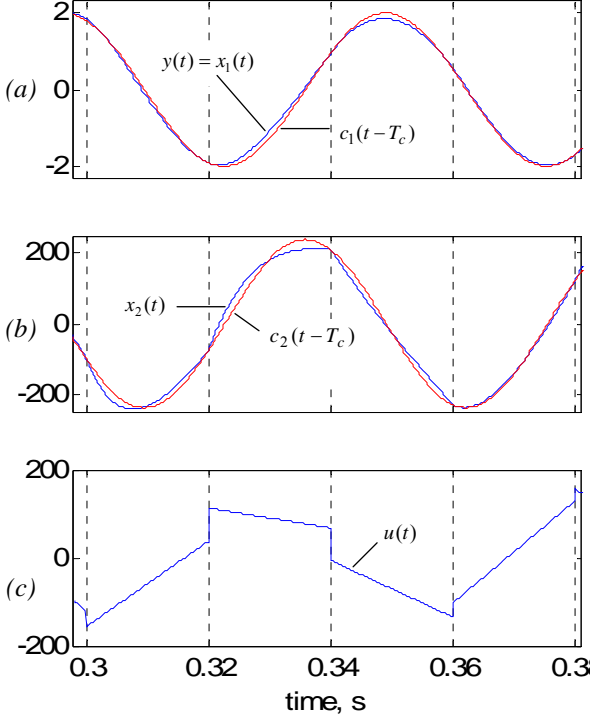

Fig. 6. Tracking ($T_c = 20$ ms , $a = 2$ and $\omega = 38\pi$ rad/s)

Note that the $x_1(t)$ and $x_2(t)$ curves intersect those of $c_1(t - T_c)$ and $c_2(t - T_c)$ respectively at every kT_c , thus showing T_c -sampled tracking with a delay of T_c . These results can be better appreciated on Figs. 6a and 6b respectively.

In the same way, Fig. 5b represents sampled tracking of $c_1(t)$ by $z(t)$ with a delay equal to $T_c + t_e$ (since $D = t_e$ in the present example).

Fig. 5e and Fig. 6c illustrate the control command fed to the plant. Coming out of a PCS controller, we can notice its piecewise continuous nature.

On the other hand, Fig. 5d shows how the estimated state follows continuously the actual plant's state. Moreover, to illustrate the high performance of the observer, we consider in Fig. 7 the case where the initial condition of the plant's state is unknown to the observation block.

Note that though we have shown the state's evolution for demonstration sake, we do not use it for feedback, since we assume it to be unavailable.

VII. CONCLUSION

The method that we present in this paper is appropriate for control of linear plants in cases where the only available feedback comes from a sensor delivering the plant's output vector in a delayed (of D) and sampled (at t_e) format. The proposed observer reconstitutes the current

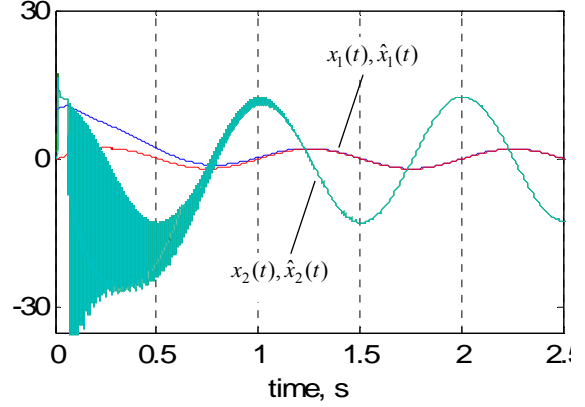

Fig. 7. State observation, $a = 2$ and $\omega = 2\pi$ rad/s)

state of the plant from the sensor's output enabling fast convergence of the estimated state towards the actual state, even in cases of unknown initial conditions of the latter. State observation also holds for varying delay and sampling period, given their upper and lower limits.

The control unit is based on a PCS controller which makes use of the estimated state and guarantees sampled tracking of a given state trajectory $c(t)$. It ensures at each kT_c ($\forall k = 0, 1, 2, \dots$):

$$\begin{aligned} x(t) &= c(t - T_c), \\ z(t) &= C.c(t - T_c - D). \end{aligned}$$

With our notations, this tracking can be expressed by:

$$\begin{aligned} x(kT_c) &= c((k-1)T_c) \quad \forall k = 0, 1, 2, \dots, \\ z(kT_c) &= C.c((k - N.q - 1)T_c) \quad \forall k = 0, 1, 2, \dots. \end{aligned}$$

Computer simulations showed that the method is reliable and moreover robust against slight time-variations of the plant's parameters.

Note that in every case, the PCS controller show better efficiency for small values of T_c , which is the period at which the PCS controller's state switches.

As a perspective of our study, works are presently being carried out to optimize the PCS controller to ameliorate its behavior between switching instants so as to enhance the tracking in this interval. This optimization is based on that given in [KON, 03]. Moreover, we intend to realize a controller based on the bi-sampled controller [KON, 02] that outputs a sampled command between switching instants.

Furthermore, we are undertaking real time experiments to test the present method on the real system of Fig. 4.

ACKNOWLEDGEMENTS

This work is supported by the European Union under Grants 15010/02Y0064/03-04 CAR/Presage N° 4605 Obj. 2-2004:2 - 4.1 – N° 160/4605.

REFERENCES

- [BRA, 94] M. S. Branicky, V. Borkar and S. K. Mitter, "A unified framework for hybrid control," in *Proceedings IEEE Conf. Decision Contr.*, Lake Buena Vista, 1994, pp. 4228-4234.
- [FRI, 04] E. Fridman, A. Seuret and J.-P. Richard, "Robust sampled-data stabilization of linear systems: An input delay approach," *Automatica*, vol. 40, No. 8, 2004, pp. 1441-1446.
- [KAB, 87] P. T. Kabamba, "Control of Linear Systems Using Generalized Sampled-Data Hold Functions," *IEEE Trans. Automatic Control*, Vol. 32, No. 9, 1987, pp. 772-783.
- [KON, 01] V. Koncar and C. Vasseur, "Systèmes à fonctionnement par morceaux et poursuite échantillonnée," *APII-JESA*, Vol. 35, No. 5, 2001, pp. 665-689.
- [KON, 02] V. Koncar and C. Vasseur, "Piecewise functioning systems: bi-sampled controllers," *Studies in Informatics and Control* Vol.11, No.2, 2002.
- [KON, 03] V. Koncar and C. Vasseur, "Control of linear systems using piecewise continuous systems," *IEE Control Theory & Applications*, Vol. 150, n° 6, pp.565-576, 2003.
- [LAU, 72] F. Laurent, "Sur la commande d'un filtre linéaire par des impulsions multimodulées," *C.R. Acad. Sc.*, Paris, t. 270, pp. 288-289, 1972.
- [SEU, 05] A. Seuret, E. Fridman and J.-P. Richard, "Sampled-data exponential stabilization of neutral systems with input and state delays," *IEEE MED 2005*, 13th Mediterranean. Conference on Control and Automation, Cyprus, 2005.
- [SEU, 06] A. Seuret, F. Michaut, J.-P. Richard and T. Divoux, "Networked Control using GPS Synchronization," *American Control Conference*, 2006.
- [TIT, 98] M. Tittus and B. Egardt, "Control Design for Integrator Hybrid Systems," *IEEE Trans. Automatic Control*, Vol. 43, No. 4, 1998, pp. 491-500.
- [VAS, 72] C. Vasseur, "Contribution à l'étude des systèmes échantillonnés commandés par impulsions multimodulées," Ph.D. Thesis, University Lille 1, Villeneuve d'Ascq, France, 1972.
- [YU, 04] M. Yu, L. Wang and T. Chu, "An LMI approach to network control systems with data packet dropout and transmission delays," *Mathematical Theory Networks and Systems*, Leuven, 2004.