



HAL
open science

Periodic schedules for Unitary Timed Weighted Event Graphs

Abir Benabid, Claire Hanen, Olivier Marchetti, Alix Munier-Kordon

► **To cite this version:**

Abir Benabid, Claire Hanen, Olivier Marchetti, Alix Munier-Kordon. Periodic schedules for Unitary Timed Weighted Event Graphs. 9ème Congrès de la Société Française de Recherche Opérationnelle et d'Aide à la Décision (ROADEF 2008), Feb 2008, Clermont-Ferrand, France. pp.17-31. hal-00371028

HAL Id: hal-00371028

<https://hal.science/hal-00371028v1>

Submitted on 26 Mar 2009

HAL is a multi-disciplinary open access archive for the deposit and dissemination of scientific research documents, whether they are published or not. The documents may come from teaching and research institutions in France or abroad, or from public or private research centers.

L'archive ouverte pluridisciplinaire **HAL**, est destinée au dépôt et à la diffusion de documents scientifiques de niveau recherche, publiés ou non, émanant des établissements d'enseignement et de recherche français ou étrangers, des laboratoires publics ou privés.

Periodic schedules for Unitary Timed Weighted Event Graphs

Abir Benabid-Najjar, Claire Hanen[†], Olivier Marchetti and Alix Munier-Kordon

Laboratoire d'Informatique de Paris 6

Université Pierre et Marie Curie

4 place Jussieu, 75252 Paris cedex 05, FRANCE

Email: {Abir.Benabid, Claire.Hanen, Olivier.Marchetti, Alix.Munier}@lip6.fr

Fax: (33) 1 44 27 72 80

[†] Université Paris-Ouest Nanterre la Défense

Abstract

Timed Weighted Event Graphs (in short TWEG) are widely used for modeling industrial problems or embedded systems. The aim of this paper is to develop polynomial algorithms to check the existence of periodic schedules and to compute their optimal throughput. A necessary and sufficient condition of existence of periodic schedules is first expressed. Then, we develop an algorithm to compute the optimal throughput of a periodic schedule. This theoretical work can be considered as a generalisation of Reiter's result ([1]). The gap between the optimal throughput of a TWEG and the throughput of an optimal periodic schedule is also experimentally investigated for a circuit.

Index Terms

Timed Weighted Event Graphs, Periodic Schedule.

This work has been submitted to the IEEE for possible publication. Copyright may be transferred without notice, after which this version may no longer be accessible.

This work was supported by the NANO2008 project

I. INTRODUCTION

Cyclic scheduling problems, in which a set of generic tasks T has to be performed infinitely often, have numerous practical applications in production systems (mass production) [2] or embedded systems (repeated computations or synthesis of digital signal processing) [3]. The usual objective is to maximize the throughput $\lambda = \min_{t_i \in T} \{\lambda_{t_i}\}$, where λ_{t_i} measures the mean number of occurrences of a task t_i performed by time unit. Several models for such task systems exist in the literature [4], [5], [6], [7]. In this paper we focus on the powerful subclass of Timed Petri Nets called Timed Weighted Event Graph model (TWEG), which includes both ordinary Timed Event Graph model (TEG also called marked graphs [5]) and dataflow graphs, often used in the computer science area. TWEGs model problems in which no resource conflict exists.

In the context of cyclic scheduling, transitions are generic tasks. A schedule is the time instants of the successive firings of the transitions. For a given TWEG, the first questions that arise on this model are:

- *Liveness*: does it exist an infinite schedule?
- *Optimal schedule*: is it possible to describe an infinite optimal schedule?

Both questions are polynomially solved for ordinary TEG [1], [5], [6], [8]. In particular, it has been shown that if a TEG is live, there always exists a periodic schedule with the optimal throughput (*i.e.* with the same throughput that the earliest schedule), that can be computed in polynomial time. For TWEG, the complexity of these two questions remains open. It has been shown in [9] that a quite useful subclass of TWEG called unitary TWEG can be transformed into an equivalent TEG. However, this transformation is pseudo-polynomial, and leads to graphs that might be very large even for TWEG with small number of transitions.

So challenging questions are to devise polynomial algorithms for liveness checking and for building optimal schedules. In this paper, we define periodic schedules for unitary TWEG, in which each transition t_i fires every w_i time units. A polynomial algorithm to check the existence of such a schedule and to compute the optimal periodic schedule is presented. However, unlike the TEG model, it can be observed that this algorithm might not decide whether a unitary TWEG is schedulable. Moreover, according to the throughput criterion, such a periodic schedule might not be optimal among all schedules.

This paper is organized as follows: TWEG and the main concepts for studying their behaviors

are presented in Section 2. Section 3 is devoted to the study of periodic schedules, their existence condition and their computation. In Section 4, we study for a circuit the optimal throughput of a periodic schedule and we experimentally measure its distance with the throughput of the earliest schedule. Section 5 is our conclusion.

II. PROBLEM DEFINITION

First, Weighted Event Graphs and Timed Weighted Event Graphs are defined and a small application is presented. A simple necessary condition of liveness is then recalled, leading to the definition of unitary and normalized TWEG. Some definitions specific to TWEG are lastly recalled.

A. Weighted Event Graphs

A Weighted Event Graph $\mathcal{G} = (P, T)$ (in short WEG) is given by a set of places $P = \{p_1, \dots, p_m\}$ and a set of transitions $T = \{t_1, \dots, t_n\}$. A TWEG is a decision-free Petri net *i.e.* every place $p \in P$ is defined between two transitions t_i and t_j and is denoted by $p = (t_i, t_j)$. The arcs (t_i, p) and (p, t_j) are valued by strictly positive integers denoted respectively by $w(p)$ and $v(p)$. At each firing of the transition t_i (*resp.* t_j), $w(p)$ (*resp.* $v(p)$) tokens are added to (*resp.* removed from) place p . If $v(p) = w(p) = 1$ for every place $p \in P$, then \mathcal{G} is an Event Graph (in short EG). For any integer $\nu > 0$ and any transition $t_i \in T$, $\langle t_i, \nu \rangle$ denotes the ν th firing of t_i . $C(\mathcal{G})$ denotes the set of circuits of \mathcal{G} . For any transition $t \in T$, we set $P^+(t) = \{p = (t, t') \in P, t' \in T\}$ and $P^-(t) = \{p = (t', t) \in P, t' \in T\}$.

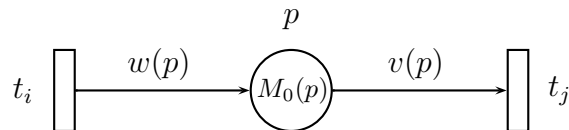

Fig. 1. A place $p = (t_i, t_j)$ of a marked WEG.

A marked Weighted Event Graph is a WEG associated with an initial marking $M_0(p), p \in P$ (*see.* Figure 1).

B. Timed Weighted Event Graphs

A Timed Weighted Event Graph (in short TWEG) is a WEG associated with a function $\ell : T \rightarrow \mathbb{N}^*$ such that, for any $t \in T$, $\ell(t)$ is the duration of a firing of t . It is usually denoted by $\mathcal{G} = (P, T, \ell)$. For every place $p = (t_i, t_j) \in P$, $w(p)$ (*resp.* $v(p)$) tokens are added to (*resp.* removed from) p $\ell(t_i)$ time units after the firing of t_i (*resp.* at the firing of t_j). We assume that transitions are non-reentrant *i.e.* two successive firings of the same transition cannot overlap: this is modeled by a loop place $p = (t_i, t_i)$, $\forall t_i \in T$ with $w(p) = v(p) = 1$ and $M_0(p) = 1$. For a sake of simplicity, these loops are not pictured by figures. $M(\tau, p)$ denotes the instantaneous marking of the place p at time instant $\tau \geq 0$. Clearly, $M(0, p) = M_0(p)$.

C. Example

Let us consider the assembling of products from raw materials M_1 and M_2 following three levels as pictured by Figure 2. Level 0 corresponds to the final assembling, level 2 to the loading of material raws on the line. It is also assumed that a product at level $l > 0$ may be used for only one operation at level $l - 1$. Each arc (i, j) is valued by an integer corresponding to the number of products i needed to get one product j .

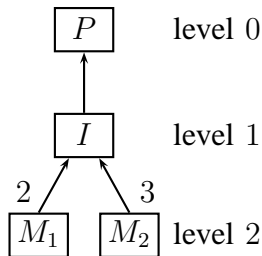

Fig. 2. Levels for the assembling of products.

Moreover, each workshop t_i is dedicated to exactly one operation (*i.e.* there is no conflict between assembling operations) and is composed by one machine (*i.e.* two distinct products cannot be assembled simultaneously by the same workshop). Operations and their corresponding durations are given by Table I.

The number of work-in-process of the line is 2. Moreover, a transporter takes 3 products and brings 6 raw materials to M_1 and 9 to M_2 . At the starting point, there are 6 raw materials in M_1 and 9 in M_2 . A model of this assembling line using a TWEG is depicted by Figure 3.

workshop	t_1	t_2	t_3	t_4	t_5
operations	M_1	M_2	I_1	P	\cdot
durations	2	2	2	10	12

TABLE I
WORKSHOPS AND DURATIONS OF OPERATIONS.

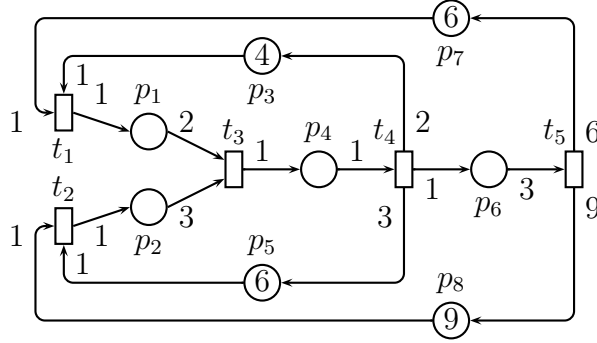

Fig. 3. Modeling an assembling line using a TWEG.

D. Liveness of a marked WEG

1) *Definition:* A marked WEG is said to be live if each transition can be fired infinitely often.

2) *Useful tokens:* For any place $p \in P$, gcd_p denotes the greatest common divisor of integers $v(p)$ and $w(p)$. It has been proved in [10] that the initial marking $M_0(p)$ of any place $p = (t_i, t_j)$ may be replaced by $M_0^*(p) = \lfloor \frac{M_0(p)}{gcd_p} \rfloor \cdot gcd_p$ without any influence on the feasible firing sequences of a WEG. In particular, the liveness property of WEG is kept. Thus in the rest of the paper, it is assumed that the initial marking $M_0(p)$ of any place $p \in P$ is a multiple of gcd_p .

3) *Algorithms and complexity:* Liveness checking of a marked EG is a polynomial problem: setting $H(c) = \sum_{p \in P \cap c} M_0(p)$ the height of a circuit c from $C(\mathcal{G})$, it is proved in [5] that M_0 is a live marking if, and only if, the height of every circuit of \mathcal{G} is not null.

Liveness checking is a slightly more complicated for marked WEG and algorithms developed up to now to answer this question are pseudo-polynomial [9].

4) *A simple necessary condition of liveness for a marked WEG:* A simple necessary condition of liveness was noticed by several authors [9], [11], [12]. For this purpose, let us define the weight

(or gain [11]) of every path μ of a Weighted Event Graph \mathcal{G} , denoted by $W(\mu)$ as

$$W(\mu) = \prod_{p \in P \cap \mu} \frac{w(p)}{v(p)}.$$

Then, if a marked Weighted Event Graph \mathcal{G} is live, every circuit has a weight not less than 1. This condition is clearly not sufficient, since it is fulfilled by any EG which is not necessarily live.

E. Unitary and Normalized WEG

In this subsection we introduce unitary WEG and normalized WEG. We also show how to compute a normalized WEG from a unitary WEG in polynomial time.

1) *Unitary graphs*: A unitary WEG \mathcal{G} is a strongly connected WEG such that every circuit of \mathcal{G} has a unit weight (or neutral gain). In the literature, unitary WEG are also called consistent WEG. It has been proved in [13] that the instantaneous marking of a WEG remains always bounded if, and only if, it is unitary. As models for which the number of tokens is unbounded are usually not realistic and according to the necessary condition of liveness exposed previously, we restrict our study to unitary WEG.

2) *Normalized WEG*: A transition t_i is normalized if there exists $Z_i \in \mathbb{N}^*$ s.t., $\forall p \in P^+(t_i)$, $w(p) = Z_i$ and $\forall p \in P^-(t_i)$, $v(p) = Z_i$. A WEG is said to be normalized if all its transitions are normalized.

In [10], it is stated that any unitary marked WEG can be polynomially transformed into an equivalent normalized WEG by multiplying marking functions and initial marking by integers $\alpha(p)$, $p \in P$ such that $\forall t_i \in T$ there exists an integer Z_i with $\forall p \in P^+(t_i)$, $\alpha(p)w(p) = Z_i$ and $\forall p \in P^-(t_i)$, $\alpha(p)v(p) = Z_i$. For any transition t_i , Z_i becomes the new marking function of every arcs adjacent to t_i . The corresponding initial marking of any place $p = (t_i, t_j)$ is then $\alpha(p)M_0(p)$. $Z = (Z_1, \dots, Z_n)$ is called a normalization vector.

The two WEGs are equivalent in the sense that they have both the same feasible schedules. Note that the normalization concept is quite different from the traditional P-invariant definition in the Petri net community. Indeed, P-invariants are place invariants whereas normalization builds TWEG for which the number of tokens per circuit is invariant.

3) *Minimal normalization algorithm:* The algorithm presented in [10] computes a feasible normalization vector. However, the transformation described above may consider rational values (instead of integer values) for $\alpha(p)$ if the normalization vector Z and the initial markings obtained are integers. Theorem 1 characterizes then the minimum normalization vector.

Theorem 1. *Let $Z^* = (Z_1, \dots, Z_n)$ the minimum integer solution to the system $\Sigma(G)$ defined as:*

$$\Sigma(\mathcal{G}) : \forall p = (t_i, t_j) \in P, \frac{Z_i}{w(p)} = \frac{Z_j}{v(p)}$$

Z^* is then the minimum normalization vector.

Proof: Every normalization vector Z verifies $\Sigma(\mathcal{G})$. Thus, if Z^* is a feasible normalization vector, it is the minimum normalization vector.

- 1) By $\Sigma(\mathcal{G})$, $Z^* \in \mathbb{N}^{*n}$. It remains to prove that, for every place $p = (t_i, t_j)$, the initial marking $M_0^*(p) = \frac{Z_i^*}{w(p)} M_0(p)$ is an integer value.
- 2) Clearly, $M_0^*(p) = \frac{Z_i^*}{w(p)} \cdot \frac{M_0(p)}{gcd_p} \cdot gcd_p$. Since $M_0(p)$ may be divided by gcd_p using useful tokens assumption, we must prove that Z_i^* can be divided by $\frac{w(p)}{gcd_p}$.

Let $\Delta \in \mathbb{Q}^*$ such that $Z_i^* = \Delta \cdot \frac{w(p)}{gcd_p}$ and $Z_j^* = \Delta \cdot \frac{v(p)}{gcd_p}$. If $\Delta \in \mathbb{Q}^* \setminus \mathbb{N}^*$, then there is a couple of integers $(r, q) \in \mathbb{N}^{*2}$ such that $gcd(r, q) = 1$ and $\Delta = \frac{r}{q}$. Since $Z_i^* = \frac{r}{q} \cdot \frac{w(p)}{gcd_p}$ and $Z_j^* = \frac{r}{q} \cdot \frac{v(p)}{gcd_p}$ are both in \mathbb{N} , then q divides $\frac{w(p)}{gcd_p}$ and $\frac{v(p)}{gcd_p}$. Since $\frac{w(p)}{gcd_p}$ and $\frac{v(p)}{gcd_p}$ are prime to each other, there is a contradiction. So $\Delta \in \mathbb{N}^*$ which achieves the proof. ■

The minimum normalization vector Z^* may be computed using a path algorithms similar to the one presented in [9].

4) *Example:* Let us consider the example pictured by Figure 3. It can be observed that this unitary TWEG is not normalized. Setting $\alpha(p_1) = 3$, $\alpha(p_2) = 2$, $\alpha(p_3) = 3$, $\alpha(p_4) = 6$, $\alpha(p_5) = 2$, $\alpha(p_6) = 6$, $\alpha(p_7) = 3$ and $\alpha(p_8) = 2$, we get the minimum normalized TWEG pictured by Figure 4. The normalization vector is $Z = (3, 2, 6, 6, 18)$.

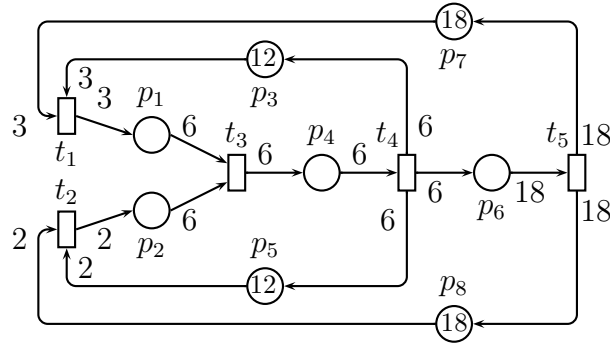

Fig. 4. Equivalent minimum normalized TWEG.

F. Schedules, precedences, and throughput of TWEGs

1) *Schedules*: Let \mathcal{G} be a marked TWEG. A schedule is a function $s : T \times \mathbb{N}^* \rightarrow \mathbb{Q}^+$ which associates, with any tuple $(t_i, q) \in T \times \mathbb{N}^*$, the starting time of the q th firing of t_i . There is a strong relationship between a schedule and the corresponding instantaneous marking. Let $p = (t_i, t_j)$ be a place of P . For any value $\tau \in \mathbb{R}^{+*}$, let us denote by $E(\tau, t_i)$ the number of firings of t_i completed at time τ . More formally,

$$E(\tau, t_i) = \max\{q \in \mathbb{N}, s(t_i, q) + \ell(t_i) \leq \tau\}.$$

On the same way, $B(\tau, t_j)$ denotes the number of firings of t_j started up to time τ and

$$B(\tau, t_j) = \max\{q \in \mathbb{N}, s(t_j, q) \leq \tau\}.$$

Clearly,

$$M(\tau, p) = M(0, p) + w(p) \cdot E(\tau, t_i) - v(p) \cdot B(\tau, t_j).$$

A schedule (and its corresponding marking) is feasible if $M(\tau, p) \geq 0$ for every tuple $(\tau, p) \in \mathbb{R}^{+*} \times P$. The throughput of a transition t_i for a schedule s is defined by

$$\lambda_{t_i}^s = \lim_{q \rightarrow \infty} \frac{q}{s(t_i, q)}.$$

The throughput of s is the smallest throughput of a transition

$$\lambda^s = \min_{i \in T} \{\lambda_{t_i}^s\}.$$

2) *Precedence relations*: The set of constraints induced by a place $p = (t_i, t_j)$ on the firings of the adjacent transitions t_i and t_j may be expressed as classical precedence relations, inducing inequalities on each schedule. We say that p generates a precedence constraint between $\langle t_i, \nu_i \rangle$ and $\langle t_j, \nu_j \rangle$ if

Condition 1: $\langle t_j, \nu_j \rangle$ can be done after $\langle t_i, \nu_i \rangle$;

Condition 2: $\langle t_j, \nu_j - 1 \rangle$ can be done before $\langle t_i, \nu_i \rangle$ but not $\langle t_j, \nu_j \rangle$.

Such a precedence relation induces the following inequality for any schedule:

$$s(t_i, \nu_i) + \ell(t_i) \leq s(t_j, \nu_j). \quad (1)$$

The following lemma was proved in [9] and characterizes the set of precedence relations induced by a place:

Lemma 1. *A place $p = (t_i, t_j) \in P$ induces a precedence relation between the ν_i th firing of t_i and the ν_j th firing of t_j if, and only if,*

$$w(p) > M_0(p) + w(p)\nu_i - v(p)\nu_j \geq \max\{w(p) - v(p), 0\}.$$

Precedence relations fully define feasible schedules of a TWEG. Indeed, in [9] it is proved that a schedule fulfils the precedence relations defined by Lemma 1 if and only if it is feasible.

According to the definition of precedence constraint and the previous lemma, one can check that the place $p = (t_i, t_j)$ depicted by Figure 5 induced for any $k \in \mathbb{N}$ the two following sets of precedence constraints between t_i and t_j :

$$\begin{cases} \langle t_i, 1 + 2k \rangle \rightarrow \langle t_j, 1 + 3k \rangle \\ \langle t_i, 2 + 2k \rangle \rightarrow \langle t_j, 3 + 3k \rangle \end{cases}$$

In [9], it is stated that there is exactly $\min\{w(p), v(p)\}$ different sets of precedence constraints induced by a place p (as depicted by Figure 1), which is exponential in the size of the instance.

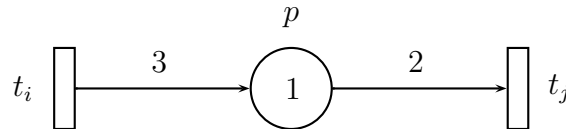

Fig. 5. A place $p = (t_i, t_j)$ which induces two types of precedence constraints.

3) *Earliest schedule*: Notice that for live marked TWEG, the earliest schedule (which consists in firing the transitions as soon as possible) always exists and has a maximum throughput. For marked TEGs, computing the throughput of the earliest schedule can be done polynomially [6], [14], but it has an unknown theoretical complexity for marked unitary TWEGs. If n is the number of transitions and A denotes the highest marking function value, the time complexity of the algorithms developed until now for computing the optimal throughput is $O(n^5 + (nA^n)^3 \log(nA^n))$ [9], [15]. Hence, it is not polynomial because of the term in A .

4) *Periodic schedules*: A schedule s is periodic if there exists a vector $w = (w_1, \dots, w_n) \in \mathbb{Q}^n$ such that, for any couple $(t_i, q) \in T \times \mathbb{N}^*$, $s(t_i, q) = s(t_i, 1) + (q - 1)w_i$. w_i is then the period of the transition t_i and $\lambda_{t_i}^s = \frac{1}{w_i}$ its throughput. Periodic schedules are of high interest from a practical point of view, because their representation is compact so that they can be easily implemented in real systems.

G. Problem formulation

According to the previous section, any TWEG can be normalized, so from now, we shall only consider normalized TWEGs. The two problems addressed in this paper can then be expressed as follows:

1) *Existence of a periodic schedule for a marked normalized TWEG*

Input: \mathcal{G} is a marked normalized TWEG.

Question: Is there a feasible periodic schedule for \mathcal{G} ?

2) *Computation of an optimal periodic schedule for a marked normalized TWEG*

Input: \mathcal{G} is a marked normalized TWEG.

Output: If it exists, a feasible periodic schedule with maximum throughput.

III. STUDY OF PERIODIC SCHEDULES

This section is devoted to the study of periodic schedules of a TWEG. It is proved that every place p induces an inequality on the starting time of the first firings of its adjacent transitions. A necessary and sufficient condition for the existence of a periodic schedule and a polynomial algorithm to compute a periodic schedule are derived.

A. Properties of periodic schedule

Let us first consider an important property of precedence relations induced by a place, which will be used in Theorem 2 to prove feasibility conditions of periodic schedules.

Lemma 2. *Let us consider a place $p = (t_i, t_j) \in P$, and let the integer values $k_{min} = \frac{\max\{w(p) - v(p), 0\} - M_0(p)}{gcd_p}$ and $k_{max} = \frac{w(p) - M_0(p)}{gcd_p} - 1$.*

- 1) *If p induces a precedence relation between the firings $\langle t_i, \nu_i \rangle$ and $\langle t_j, \nu_j \rangle$ then there exists $k \in \{k_{min}, \dots, k_{max}\}$ such that $w(p)\nu_i - v(p)\nu_j = k \cdot gcd_p$.*
- 2) *Conversely, for any $k \in \{k_{min}, \dots, k_{max}\}$, there exist an infinite number of tuples $(\nu_i, \nu_j) \in \mathbb{N}^{*2}$ such that $w(p)\nu_i - v(p)\nu_j = k \cdot gcd_p$ and p induces a precedence relation between firings $\langle t_i, \nu_i \rangle$ and $\langle t_j, \nu_j \rangle$.*

Proof:

- 1) Since $gcd_p = gcd(v(p), w(p))$, for any tuple $(\nu_i, \nu_j) \in \mathbb{N}^{*2}$ there exists $k \in \mathbb{Z}$ such that $w(p)\nu_i - v(p)\nu_j = k \cdot gcd_p$. Now, if there is a precedence relation between $\langle t_i, \nu_i \rangle$ and $\langle t_j, \nu_j \rangle$, we get by Lemma 1, as we assumed that $M_0(p)$ is a multiple of gcd_p ,

$$w(p) - M_0(p) > w(p)\nu_i - v(p)\nu_j \geq \max\{w(p) - v(p), 0\} - M_0(p),$$

which is equivalent to

$$w(p) - M_0(p) - gcd_p \geq k \cdot gcd_p \geq \max\{w(p) - v(p), 0\} - M_0(p).$$

So we get $k_{min} \leq k \leq k_{max}$.

- 2) Conversely, there exists $(a, b) \in \mathbb{Z}^2$ such that $aw(p) - bv(p) = gcd_p$. Then for any $k \in \{k_{min}, \dots, k_{max}\}$, and any integer $q \geq 0$, the couple of integers $(\nu_i, \nu_j) = (ka + qv(p), kb + qw(p))$ is such that $w(p)\nu_i - v(p)\nu_j = k \cdot gcd_p$. Thus p induces a precedence relation between $\langle t_i, \nu_i \rangle$ and $\langle t_j, \nu_j \rangle$, which achieves the proof. ■

Theorem 2. *Let \mathcal{G} be a unitary normalized TWEg. For any periodic schedule s , there exists a rational $K \in \mathbb{Q}^{*+}$, called the **token flow** of s such that, for any couple of transitions $(t_i, t_j) \in T^2$, $\frac{w_i}{Z_i} = \frac{w_j}{Z_j} = K$. Moreover, the precedence relations associated with any place $p = (t_i, t_j)$ are fulfilled by s iff*

$$s(t_j, 1) - s(t_i, 1) \geq \ell(t_i) + K(Z_j - M_0(p) - gcd_p).$$

Proof: Let be a place $p = (t_i, t_j) \in P$ inducing a precedence relation between the firings $\langle t_i, \nu_i \rangle$ and $\langle t_j, \nu_j \rangle$. Then, according to inequality 1 page 9, and since s is periodic, we get

$$s(t_i, 1) + (\nu_i - 1) \cdot w_i + \ell(t_i) \leq s(t_j, 1) + (\nu_j - 1) \cdot w_j.$$

Then, by Lemma 2, there exists $k \in \{k_{min}, \dots, k_{max}\}$ such that $\nu_j = \frac{w(p)\nu_i - k \cdot gcd_p}{v(p)}$ and

$$s(t_j, 1) - s(t_i, 1) \geq \ell(t_i) + w_j - w_i + \nu_i w_i - \frac{w(p)\nu_i - k \cdot gcd_p}{v(p)} \cdot w_j.$$

So,

$$s(t_j, 1) - s(t_i, 1) \geq \ell(t_i) + \left(w_i - \frac{w(p)}{v(p)} w_j \right) \nu_i + \left(1 + \frac{k \cdot gcd_p}{v(p)} \right) w_j - w_i.$$

This inequality must be true for arbitrarily large values $\nu_i \in \mathbb{N}^*$, so $w_i - \frac{w(p)}{v(p)} w_j \leq 0$ and then $\frac{w_i}{w(p)} \leq \frac{w_j}{v(p)}$. As \mathcal{G} is normalized, $w(p) = Z_i$ and $v(p) = Z_j$. Since \mathcal{G} is unitary, it is strongly connected and thus, for any place $p = (t_i, t_j)$, $\frac{w_i}{Z_i} = \frac{w_j}{Z_j}$. So, there exists a value $K \in \mathbb{Q}^*$ such that, for any transition $t_i \in T$, $\frac{w_i}{Z_i} = K$. Then, the previous inequality becomes

$$s(t_j, 1) - s(t_i, 1) \geq \ell(t_i) + K Z_j \left(1 + \frac{k \cdot gcd_p}{Z_j} \right) - K Z_i$$

and thus

$$s(t_j, 1) - s(t_i, 1) \geq \ell(t_i) + K(Z_j - Z_i + k \cdot gcd_p).$$

Now, the right term grows with k and according to Lemma 2, there exists $(\nu_i, \nu_j) \in \mathbb{N}^{*2}$ such that $k = k_{max} = \frac{Z_i - M_0(p)}{gcd_p} - 1$, thus the precedence relation holds if, and only if,

$$s(t_j, 1) - s(t_i, 1) \geq \ell(t_i) + K(Z_j - Z_i + Z_i - M_0(p) - gcd_p)$$

which is equivalent to

$$s(t_j, 1) - s(t_i, 1) \geq \ell(t_i) + K(Z_j - M_0(p) - gcd_p).$$

Conversely, assume this last inequality and that $\forall t_i \in T$, $\frac{w_i}{Z_i} = K$. Then, for any integers ν_i and ν_j with $w(p)\nu_i - v(p)\nu_j = k \cdot gcd_p$ for $k \in \{k_{min}, \dots, k_{max}\}$, it can be proven that s checks the precedence relation between $\langle t_i, \nu_i \rangle$ and $\langle t_j, \nu_j \rangle$ using the reverse arguments. ■

B. Existence of periodic schedules

Let us build a bi-valued graph $G = (T, E, L, H)$ as follows: nodes of G are the transitions, and any place $p = (t_i, t_j)$ induces an arc from node t_i to node t_j . Valuations of the arc $e \in E$ corresponding to a place $p = (t_i, t_j)$ are $L(e) = \ell(t_i)$ and $H(e) = M_0(p) + gcd_p - v(p)$. For any value $K \in \mathbb{Q}^{+*}$, we also denote by $G_K = (T, E, \delta_K)$ the graph G defined previously but which arcs are valued by $\delta_K(e) = L(e) - KH(e)$.

According to Theorem 2, starting times $\{s(t_i, 1), t_i \in T\}$ exists for a fixed value $K \in \mathbb{Q}^*$ if and only if, the sum of the valuations on every circuit c of G_K is such that $\delta_K(c) = \sum_{e \in c} \delta_K(e) \leq 0$. This induces the following necessary and sufficient existence condition of periodic schedules:

Theorem 3. *Let \mathcal{G} be a normalized TWEG. There exists a periodic schedule iff, for every circuit c of G , $H(c) > 0$. Moreover, if this condition is fulfilled, and if*

$$K_{min} = \max_{c \in \mathcal{C}(\mathcal{G})} \frac{L(c)}{H(c)}, \text{ and } Z_{max} = \max_{t_i \in T} \{Z_i\}$$

then for any $K \geq K_{min}$ there exists a periodic schedule s with token flow K and throughput

$$\lambda^s = \frac{1}{K Z_{max}}.$$

Proof:

$A \Rightarrow B$ Let us suppose that there exists a circuit c of G with $H(c) \leq 0$. Then, for every value $K \in \mathbb{Q}^{+*}$, $\delta_K(c) > 0$ and no periodic schedule exists.

$B \Rightarrow A$ Let us suppose now that, for every circuit c of G , $H(c) > 0$. Let us consider any $K \geq K_{min}$. Then, for every circuit c of G_K , $\delta_K(c) \leq 0$, so there exists a periodic schedule with token flow K . The period of a task i in this schedule is $w_i = K Z_i$, so that the throughput of the schedule is $\lambda^s = \frac{1}{\max_{i \in \{1, \dots, n\}} \{w_i\}}$

■

Surprisingly, this condition is similar to a sufficient condition of liveness of a marked WEG proved in [10]. An algorithm in $\mathcal{O}(\max\{nm, m \max_{t_i \in T} \{\log Z_i\}\})$ to evaluate this condition can be found in this paper. It is also proved that this condition is a necessary and sufficient condition of liveness for circuits composed by two transitions. So, the following corollary is easily deduced:

Corollary 1. *Let \mathcal{G} be a normalized marked TWEG composed by a circuit of two transitions. \mathcal{G} is live if and only if \mathcal{G} has a periodic schedule.*

This corollary is not true anymore for circuits with 3 transitions. For example, let us consider the normalized TWEG \mathcal{G} presented by Figure 6 with no particular assumption on firing durations. The sequences of firings $s = t_3 t_1 t_1 t_2 t_3 t_1 t_1 t_1 t_2 t_2$ can be repeated infinitely, so it is live. However, $\sum_{i=1}^3 M_0(p_i) = 28$ and $\sum_{i=1}^3 (v(p_i) - gcd_{p_i}) = 29$, so the condition of Theorem 3 is false and this circuit has no periodic schedule.

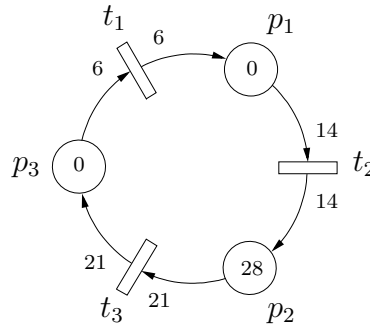

Fig. 6. \mathcal{G} is live but has no periodic schedule.

C. Computation of an optimal periodic schedule

Assume that \mathcal{G} is a normalized TWEG which fulfils the condition expressed by Theorem 3. According to this theorem the optimal throughput of a periodic schedule s_{per}^* for \mathcal{G} is defined by the minimum token flow K_{min} . Then $\lambda^{s_{per}^*} = \frac{1}{K_{min} Z_{max}}$ where $Z_{max} = \max_{i \in \{1, \dots, n\}} \{Z_i\}$.

Several polynomial and pseudo-polynomial algorithms were developed to compute K_{min} (see as example [16], [17], [18]). An experimental study of these algorithms can be found in [19]. Corresponding starting times $\{s(t_i, 1), t_i \in T\}$ can then be computed using Bellmann-Ford algorithm [20] on $G_{K_{min}}$.

1) *Example:* Figure 7 presents the bi-valued graph G associated with the TWEG pictured by Figure 4. Note that the necessary and sufficient condition expressed by Theorem 3 is fulfilled, so a periodic schedule exists. We get here $K_{min} = 13$ for the circuit $c = t_2 t_3 t_4 t_5 t_2$, so the optimum periods of the transitions are $w_1 = 39$, $w_2 = 26$, $w_3 = 78$, $w_4 = 78$ and $w_5 = 234$.

Figure 8 presents the graph G_{13} for our example pictured by Figure 4 and starting times $\{s(t_i, 1), t_i \in T\}$.

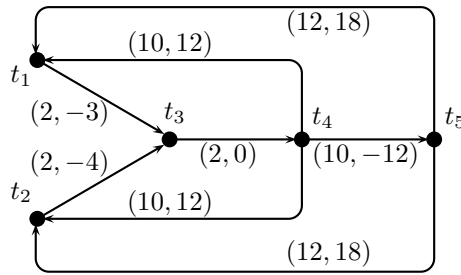

Fig. 7. A bi-valued graph G associated with the TWEG of Figure 4.

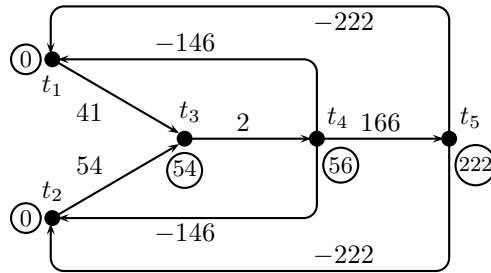

Fig. 8. G_{13} and starting times $s(t_i, 1), t_i \in T$ (in circles) associated with the TWEG of Figure 4.

2) *Optimal periodic versus optimal schedule:* Now, we can observe that the throughput of a periodic schedule may be quite far from the optimum. For example, let us consider a marked normalized TWEG which consists in a circuit with two places $p_1 = (t_1, t_2), p_2 = (t_2, t_1)$ such that $gcd_{p_1} = gcd_{p_2} = 1, M_0(p_1) = v(p_1) + w(p_1) - 1 = Z_2 + Z_1 - 1$ and $M_0(p_2) = 0$. This TWEG fulfils the condition stated in Theorem 3 : $M_0(p_1) + M_0(p_2) + gcd_{p_1} + gcd_{p_2} - Z_2 - Z_1 = 1$. The associated graph G is then pictured by Figure 9.

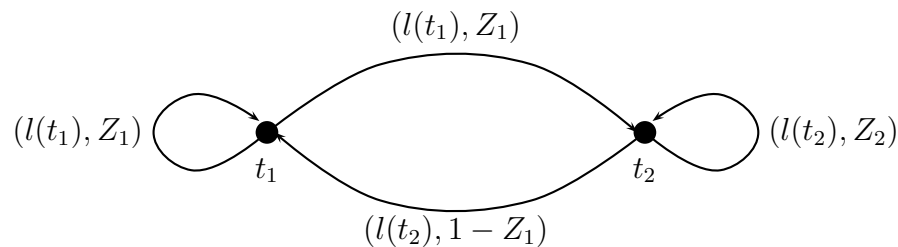

Fig. 9. Bi-valued graph G associated with the normalized TWEG with two places.

We get $K_{min} = \max \left\{ \frac{\ell(t_1)}{Z_1}, \frac{\ell(t_2)}{Z_2}, \ell(t_1) + \ell(t_2) \right\} = \ell(t_1) + \ell(t_2)$ and the throughput of transitions for the optimum periodic schedule s_{per}^* is $\lambda_{t_1}^{s_{per}^*} = \frac{1}{w_1} = \frac{1}{Z_1(\ell(t_1) + \ell(t_2))}$ and $\lambda_{t_2}^{s_{per}^*} = \frac{1}{w_2} = \frac{1}{Z_2(\ell(t_1) + \ell(t_2))}$. Now, since the total number of tokens in the circuit is $Z_1 + Z_2 - 1$, transitions t_1 and t_2 will never be fired simultaneously by the earliest schedule. Moreover, if we denote by n_1 (*resp.* n_2) the number of firings of t_1 (*resp.* t_2) such that the system will return in its initial state (*i.e.* with $Z_1 + Z_2 - 1$ tokens in p_1 and 0 tokens in p_2), then we must have $n_1 Z_1 - n_2 Z_2 = 0$, so there exists $k \in \mathbb{N}^*$ with $n_1 = k Z_2$ and $n_2 = k Z_1$. Thus, the throughput of transitions t_1 and t_2 for the earliest schedule s_{asap} is $\lambda_{t_1}^{s_{asap}} = \frac{Z_2}{Z_2 \ell(t_1) + Z_1 \ell(t_2)}$ and $\lambda_{t_2}^{s_{asap}} = \frac{Z_1}{Z_2 \ell(t_1) + Z_1 \ell(t_2)}$. Now,

$$R = \frac{\lambda_{t_1}^{s_{asap}}}{\lambda_{t_1}^{s_{per}^*}} = \frac{\lambda_{t_2}^{s_{asap}}}{\lambda_{t_2}^{s_{per}^*}} = \frac{Z_1 Z_2 (\ell(t_1) + \ell(t_2))}{Z_2 \ell(t_1) + Z_1 \ell(t_2)}.$$

Assume without loss of generality that $Z_1 \geq Z_2$, then

$$R = \frac{\lambda_{t_1}^{s_{asap}}}{\lambda_{t_1}^{s_{per}^*}} = \frac{\lambda_{t_1}^{s_{asap}}}{\lambda_{t_1}^{s_{per}^*}} = Z_1 \left(\frac{Z_2 \ell(t_1) + Z_1 \ell(t_2) - (Z_1 - Z_2) \ell(t_2)}{Z_2 \ell(t_1) + Z_1 \ell(t_2)} \right)$$

So,

$$R = Z_1 \left(1 - \frac{(Z_1 - Z_2) \ell(t_2)}{Z_2 \ell(t_1) + Z_1 \ell(t_2)} \right) < Z_1$$

The ratio R is then maximum when $\ell(t_1)$ tends to infinity and the bound $\max\{Z_1, Z_2\}$ is asymptotically reached.

IV. STUDY OF A CIRCUIT

We first present some simple properties on the optimal periodic schedule of a circuit. These properties are considered to study experimentally the gap between the throughput of a schedule with the *asap* scheduling policy and the maximum throughput of a periodic schedule for the same initial marking.

A. Periodic schedule of a circuit

The TWEG studied here is a circuit of n transitions and n places, $n \geq 2$ denoted by $\mathcal{C} = (t_1, p_1, t_2, \dots, t_n, p_n, t_1)$. We also set $t_{n+1} = t_1$ in order to simplify formulas. Let us consider $x = \sum_{t_i \in T} M_0(p)$, and we define by $K_{min}(x)$ the minimum token flow of the circuit for an initial marking value x . We now study this token flow as a function of x .

Let us set

$$\mathcal{V} = \sum_{i=1}^n (Z_i - \gcd(Z_i, Z_{i+1})).$$

According to Theorem 3, a periodic schedule exists iff $H(\mathcal{C}) > 0$, i.e. $x \geq x_{min} = \mathcal{V} + 1$. Now, assuming $x \geq x_{min}$, we get:

$$K_{min}(x) = \max_{c \in \mathcal{C}(\mathcal{G})} \left\{ \frac{L(c)}{H(c)} \right\} = \max \left\{ \max_{t_i \in T} \left\{ \frac{\ell(t_i)}{Z_i} \right\}, \frac{L(\mathcal{C})}{H(\mathcal{C})} \right\} = \max \left\{ \max_{t_i \in T} \left\{ \frac{\ell(t_i)}{Z_i} \right\}, \frac{L(\mathcal{C})}{x - \mathcal{V}} \right\}.$$

Notice that tokens distribution in the initial marking has no incidence on the minimum token flow. Due to the fact that transitions are non-reentrant, we can define K^* as the lower bound of $K_{min}(x)$:

$$K^* = \max_{t_i \in T} \left\{ \frac{\ell(t_i)}{Z_i} \right\}.$$

Let x_{max} be the minimum integer value such that $K_{min}(x) = K^*$. Then, we have: $\frac{L(\mathcal{C})}{x_{max} - \mathcal{V}} \leq K^*$ and $\frac{L(\mathcal{C})}{x_{max} - 1 - \mathcal{V}} > K^*$.

Thus,

$$x_{max} = \left\lceil \frac{L(\mathcal{C})}{K^*} \right\rceil + \mathcal{V}.$$

Now, if $x_{min} \leq x \leq x_{max}$, then $K_{min}(x) = \frac{L(\mathcal{C})}{x - \mathcal{V}}$. Theorem 4 follows.

Theorem 4. *The throughput of an optimal periodic schedule for the circuit \mathcal{C} with x initial tokens is:*

$$\lambda_{per}^{s^*}(x) = \begin{cases} \frac{x - \mathcal{V}}{L(\mathcal{C})} \cdot \frac{1}{Z_{max}} & \text{if } x_{min} \leq x < x_{max}, \\ \frac{1}{K^*} \cdot \frac{1}{Z_{max}} & \text{if } x \geq x_{max}. \end{cases}$$

Unlike x_{min} , the value x_{max} depends on the durations $\{\ell(t_i), t_i \in T\}$. The following theorem defines an upper bound for x_{max} which does not depend on the durations. For this purpose, let us define x^* as follows:

$$x^* = \sum_{i=1}^n Z_i + \mathcal{V}.$$

Theorem 5. $x_{max} \leq x^*$. Moreover, if there exists $\rho \in \mathbb{Q}^{+*}$ such that, $\forall i \in \{1, \dots, n\}$, $\frac{\ell(t_i)}{Z_i} = \rho$, then $x^* = x_{max}$.

Proof:

By definition of x_{max} and x^* , we have to show that

$$\left\lceil \frac{L(\mathcal{C})}{K^*} \right\rceil + \mathcal{V} \leq \sum_{i=1}^n Z_i + \mathcal{V}.$$

As $\sum_{i=1}^n Z_i$ is in \mathbb{N} , it is equivalent to prove that

$$\frac{L(\mathcal{C})}{K^*} \leq \sum_{i=1}^n Z_i.$$

Let $i^* \in \{1, \dots, n\}$ such that $\frac{\ell(t_{i^*})}{Z_{i^*}} = \max_{t_i \in T} \left\{ \frac{\ell(t_i)}{Z_i} \right\}$. Then, for all $t_i \in T$, it follows that $\ell(t_i)Z_{i^*} \leq \ell(t_{i^*})Z_i$, and thus

$$\begin{aligned} Z_{i^*} \sum_{i=1}^n \ell(t_i) &\leq \ell(t_{i^*}) \sum_{i=1}^n Z_i \\ \frac{\sum_{i=1}^n \ell(t_i)}{\sum_{i=1}^n Z_i} &\leq \max_{t_i \in T} \left\{ \frac{\ell(t_i)}{Z_i} \right\} \\ \frac{L(\mathcal{C})}{K^*} &\leq \sum_{i=1}^n Z_i. \end{aligned}$$

Now, if there exists $\rho \in \mathbb{Q}^{++}$ such that, $\forall i \in \{1, \dots, n\}$, $\frac{\ell(t_i)}{Z_i} = \rho$, then $K^* = \rho$ and we have

$$x_{max} = \left\lceil \frac{L(\mathcal{C})}{K^*} \right\rceil + \mathcal{V} = \left\lceil \frac{\sum_{i=1}^n \rho Z_i}{\rho} \right\rceil + \mathcal{V} = \sum_{i=1}^n Z_i + \mathcal{V} = x^*$$

Hence, the second part of the theorem. ■

A simple outcome of Theorem 5 is that $K_{min}(x^*) = K^*$.

As transitions are non-reentrant, the best throughput of a schedule with the *asap* scheduling policy is also limited by

$$\lambda^{s_{asap}}(x) \leq \frac{1}{K^* Z_{max}}, \quad \forall x \geq x_{min}.$$

As the throughput of a schedule with the *asap* scheduling policy is optimum, we have

$$\lambda^{s_{asap}}(x) \geq \lambda^{s_{per}^*}(x), \quad \forall x \geq x_{min}.$$

Then $\forall x \geq x_{max}$,

$$\lambda^{s_{asap}}(x) = \frac{1}{K^* Z_{max}} = \lambda^{s_{per}^*}(x).$$

However, a schedule with the *asap* scheduling policy may reach this maximum throughput for a smaller value of x . For instance, we consider a marked normalized TWEG which consists in a circuit of two places $p_1 = (t_1, t_2)$, $p_2 = (t_2, t_1)$ and such that $\ell(t_1) = 4$ and $\ell(t_2) = 2$ (see Figure 10). For this initial marking, we have $K_{min} = 1.5$ and then $w_1 = 4.5$ and $w_2 = 3$. One can see on Figure 10, that the schedule s_{per}^* has idle times for both transitions whereas t_1 can be fired periodically without idle time in the schedule s_{asap} .

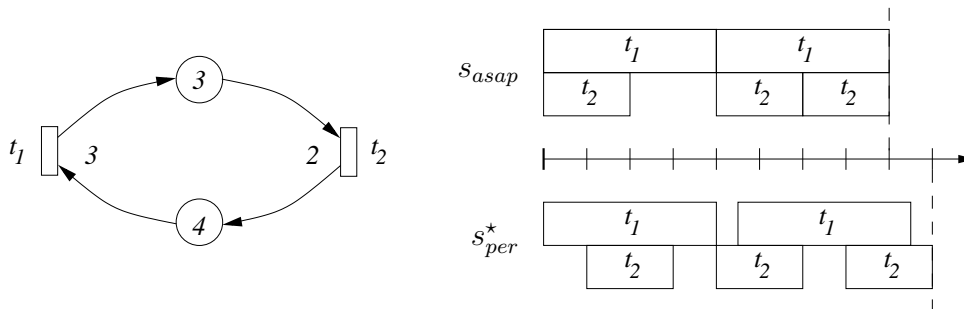

Fig. 10. A TWEG \mathcal{G} for which the schedule s_{asap} reaches the best throughput whereas the schedule s_{per}^* cannot.

B. Periodic optimal throughput versus optimal throughput

We made our experiments on a randomly generated normalized circuit \mathcal{C} in order to analyze the ratio R between optimal throughput and periodic optimal throughput.

For any fixed integer value n corresponding to the number of transitions, the integer values Z_i and the durations $\ell(t_i)$, $i \in \{1, \dots, n\}$ are randomly fixed respectively in $\{1, \dots, 100\}$ and $\{1, \dots, 50\}$. By Theorem 4 and Theorem 5, the relevant number of tokens is in $\{x_{min}, \dots, x^*\}$. Thus, we set $x = x_{min} + \lceil f \cdot \sum_{i=1}^n Z_i \rceil$ for different values of f (from 0 to 1 with step 0.02). The optimal throughput was obtained by running the earliest schedule and analyzing its throughput after a while.

We first considered the special case $f = 0$, depicted by Figure 11, for which the initial marking is the minimum number such that there exists a periodic schedule. It appears that the ratio may then be very important (up to 268) and much greater than the bound observed for circuits with two transitions. Moreover, the mean and max ratio roughly increase with the number of transitions, even if some decreasing parts can be observed.

Then we observed that even for other quite small values of f , the mean and max ratio decrease with the number of transitions. The mean ratio is less than 1.8 for $n \geq 10$, and very close to 1 for $n \geq 50$.

Figure 12 shows the variation of the ratio with the number of transitions.

Now, if we consider the variation of the ratio in terms of the value f , depicted in Figure 13, we observe that the ratio (mean and max) decreases dramatically. For $f = 0.02$ the mean ratio equals 5, due to a very few number of instances with great ratio, whereas when $f \geq 0.08$ the mean ratio is less than 2 and reaches 1 for $f = 0.8$.

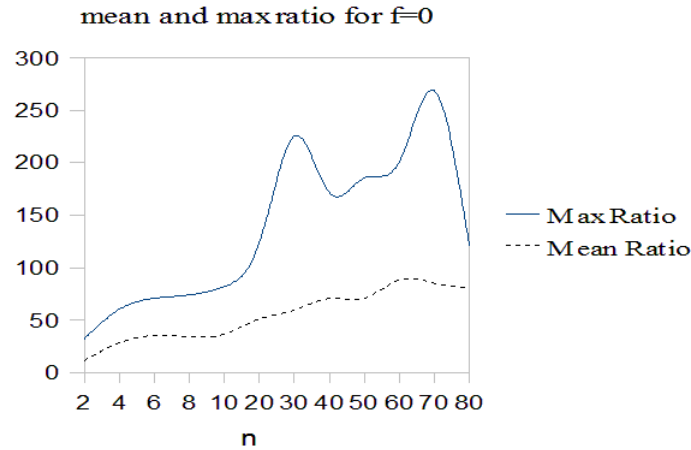

Fig. 11. Mean and worst ratio for $f = 0$ increase with the number of transitions.

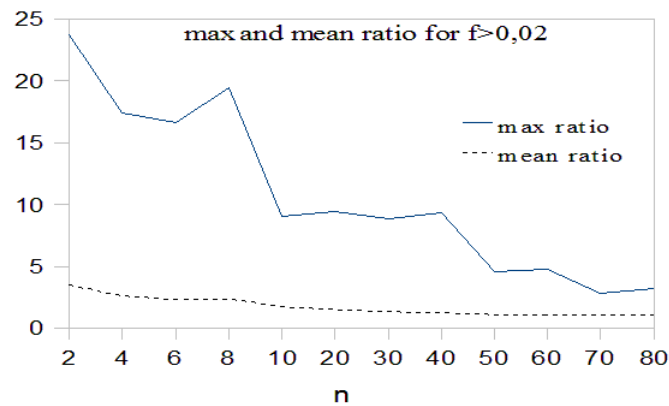

Fig. 12. Mean and max ratio decreases as the number of transitions n increases for $f \geq 0,02$.

We can also notice that in all the experiments, the mean and the max curves are quite far from each other, since the worst case instances have a huge ratio compared to the transition durations and the values of the arcs. So, periodic schedules do not always provide good solutions, especially when the initial marking is very close to the minimal value x_{min} .

This gives a first insight on the quality of the optimal periodic throughput with respect to optimal one. In the future, we shall run experiments on more complex graphs.

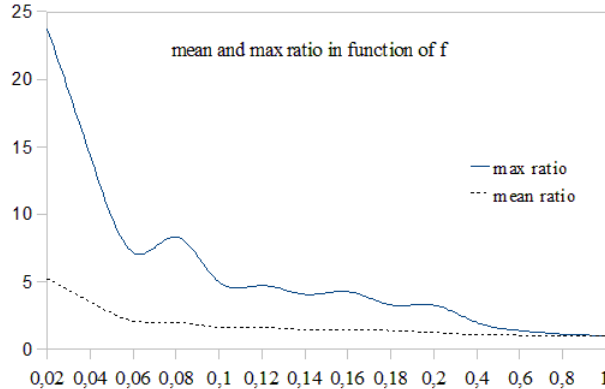

Fig. 13. Mean and worst ratio decrease when f increases.

V. CONCLUSIONS

In this paper we established an existence condition and a polynomial algorithm to compute the optimal periodic schedule of a TWEG. Experiments prove that although such schedules are not optimal, their computation gives an interesting lower bound on the optimal throughput, especially if the existence condition of Theorem 3 is not tight, *i.e.* if the initial marking of circuits is large enough.

In the future, it would be worth to derive a lower bound on the ratio between the optimal throughput and the optimal periodic throughput of a general TWEG, and to further study the complexity of the liveness problem.

REFERENCES

- [1] R. Reiter, "Scheduling parallel computations," *Journal of the Association for Computing Machinery*, vol. 15, no. 4, pp. 590–599, 1968.
- [2] J. M. Proth and X. Xie, *Les réseaux de Petri pour la conception et la gestion des systèmes de production*. Masson, 1995.
- [3] C. Hanen and A. Munier, "Cyclic scheduling on parallel processors: An overview," in *Scheduling theory and its applications*, P. Chrétienne, E. G. Coffman, J. K. Lenstra, and Z. Liu, Eds. J. Wiley and sons, 1994.
- [4] E. Levner and V. Kats, "A parametric critical path problem and an application for cyclic scheduling," *Discrete Applied Mathematics*, vol. 87, pp. 149–158, 1998.
- [5] F. Commoner, A. W. Holt, S. Even, and A. Pnueli, "Marked directed graphs." *J. Comput. Syst. Sci.*, vol. 5, no. 5, pp. 511–523, 1971.
- [6] P. Chrétienne, "Les réseaux de petri temporisés," Ph.D. dissertation, Thèse d'état, Université P. et M. Curie, 1983.

- [7] E. A. Lee and D. G. Messerschmitt, "Synchronous data flow," *IEEE Proceedings of the IEEE*, vol. 75, no. 9, 1987.
- [8] C. V. Ramamoorthy and G. S. Ho, "Performance evaluation of asynchronous concurrent systems using petri nets," *IEEE Transactions on Software Engineering*, vol. SE-6, no. 5, pp. 440–449, September 1980.
- [9] A. Munier, "Régime asymptotique optimal d'un graphe d'événements temporisé généralisé: application à un problème d'assemblage," *RAIRO-Automatique Productique Informatique Industrielle*, vol. 27, no. 5, pp. 487–513, 1993.
- [10] O. Marchetti and A. Munier-Kordon, "A sufficient condition for the liveness of weighted event graphs," *EJOR, Full version with proofs available at <http://ftp.lip6.fr/lip6/reports/2005/lip6-2005-004.pdf>*, vol. 197, no. 2, pp. 532–540, 2009.
- [11] R. M. Karp and R. E. Miller, "Properties of a model for parallel computations: Determinacy, termination, queueing," *SIAM*, vol. 14, no. 63, pp. 1390 – 1411, 1966.
- [12] E. Teruel, P. Chrastowski-Wachtel, J. M. Colom, and M. Silva, "On weighted T-systems," in *Proceedings of the 13th International Conference on Application and Theory of Petri Nets 1992, Lecture Notes in Computer Science*, vol. 616. Springer, 1992.
- [13] O. Marchetti and A. Munier-Kordon, "Minimizing place capacities of weighted event graphs for enforcing liveness," *Discrete Event Dynamic Systems*, vol. 18, no. 1, pp. 91–109, 2008.
- [14] D. Chao and D. Wang, "Iteration bounds of single-rate data flow graphs for concurrent processing," *IEEE Transactions on circuits and systems*, vol. 40, no. 9, pp. 629–634, 1993.
- [15] K. Ito and K. K. Parhi, "Determining the minimum iteration period of an algorithm," *J. VLSI Signal Process. Syst.*, vol. 11, no. 3, pp. 229–244, 1995.
- [16] G. Dantzig, W. Blattner, and M. Rao, "Finding a cycle in a graph with minimum cost to time ratio with applications to a ship routing problem," in *Theory of graphs*, P. Rosenthal, Ed. Dunod, 1966, pp. 77–83.
- [17] M. Gondran and M. Minoux, *Graphs and algorithms*, 1st ed. John Wiley and sons, 1984.
- [18] M. Gondran, "Les problèmes de ratio minimum en optimisation combinatoire," 1980, note EDF H1 3433-02.
- [19] A. Dasdan, S. Irani, and R. K. Gupta, "Efficient algorithms for optimum cycle mean and optimum cost to time ratio problems," in *Design Automation Conference*, 1999, pp. 37–42. [Online]. Available: citeseer.ist.psu.edu/dasdan99efficient.html
- [20] T. Cormen, C. Leiserson, and R. Rivest, *Introduction to Algorithms*,. MIT Press, 1990.