



HAL
open science

A first step toward combinatorial pyramids in nD spaces

Sébastien Fourey, Luc Brun

► **To cite this version:**

Sébastien Fourey, Luc Brun. A first step toward combinatorial pyramids in nD spaces. 2009. hal-00353932v1

HAL Id: hal-00353932

<https://hal.science/hal-00353932v1>

Preprint submitted on 16 Jan 2009 (v1), last revised 1 Jun 2011 (v3)

HAL is a multi-disciplinary open access archive for the deposit and dissemination of scientific research documents, whether they are published or not. The documents may come from teaching and research institutions in France or abroad, or from public or private research centers.

L'archive ouverte pluridisciplinaire **HAL**, est destinée au dépôt et à la diffusion de documents scientifiques de niveau recherche, publiés ou non, émanant des établissements d'enseignement et de recherche français ou étrangers, des laboratoires publics ou privés.

GREYC Laboratory
Groupe de Recherche en Informatique, Image,
Automatique et Instrumentation de Caen
CNRS UMR-6072
6, bd du maréchal Juin
F-14050 Caen CEDEX – France



Technical report GREYC-TR-2009-01

*A first step toward combinatorial
pyramids in nD spaces*

Sébastien Fourey and Luc Brun
{sebastien.fourey,luc.brun}@greyc.ensicaen.fr

January 2009

A first step toward combinatorial pyramids in nD spaces

Luc Brun Sébastien Fourey

*GREYC, UMR6072 – ENSICAEN, 6 bd maréchal Juin 14050 Caen CEDEX,
France*

Abstract

Combinatorial maps define a general framework which allows to encode any subdivision of an nD orientable quasi-manifold with or without boundaries. Combinatorial pyramids are defined as stacks of successively reduced combinatorial maps. Such pyramids provide a rich framework which allows to encode fine properties of the objects (either shapes or partitions). Combinatorial pyramids have first been defined in 2D. This first work has latter been extended to pyramids of nD generalized combinatorial maps. Such pyramids allow to encode stacks of non orientable partitions but at the price of a twice bigger pyramid. These pyramids are also not designed to capture efficiently the properties connected with orientation. The present work presents our first result on the design of an nD pyramid of combinatorial maps.

Contents

1	Introduction	2
2	Combinatorial maps	3
2.1	Basic definitions	3
2.2	From maps to G-maps and vice versa	7
2.3	Cells in maps	11
3	Cells removal and contraction in G-maps and maps	34
3.1	Cells removal	34
3.2	Cells contraction	45

Email addresses: Luc.Brun@greyc.ensicaen.fr (Luc Brun),
Sebastien.Fourey@greyc.ensicaen.fr (Sébastien Fourey).

4	Conclusion and perspectives	50
	References	51

1 Introduction

Pyramids of combinatorial maps have first been defined in 2D [1], and latter extended to pyramids of n -dimensional generalized maps by Grasset et al. [6]. Generalized maps model subdivisions of orientable but also non-orientable quasi-manifolds [7] at the expense of twice the data size of the one required for combinatorial maps. For practical use (for example in image segmentation), this may have an impact on the efficiency of the associated algorithms or may even prevent their use. Furthermore, properties and constrains linked to the notion of orientation may be expressed in a more natural way with the formalism of combinatorial maps. For these reasons, we are interested here in the definition of pyramids of n -dimensional combinatorial maps. This paper is a first step toward the definition of such pyramids, and the link between our definitions and the ones that consider G-maps is maintained throughout the paper. In fact, the link between n -G-maps and n -maps was first established by Lienhardt [7] so that it was claimed in [3], but not explicitly stated, that pyramids of n -maps could be defined.

The key notion for the definition of pyramids of maps is the operation of simultaneous removal or contraction of cells that satisfy some criterions. Thus, we define the operation of simultaneous removal and the one of simultaneous contraction of cells in an n -map, the latter being introduced here as a removal operation in the dual map.

We first raise in Section 3.1 a minor problem with the definition of "cells with local degree 2 in a G-map" used in [5,3] and more precisely with the criterion for determining if a cell is a valid candidate for removal. We provide a formal definition of the local degree, which is consistent with the results established in the previous papers, using the notion of a *regular cell* that we introduce.

An essential result of this paper, presented in Section 3.1, is that the removal operation we introduce here is well defined since it indeed transforms a map into another map. Instead of checking that the resulting map satisfies from its very definition the properties of a map, we use an indirect proof by using the removal operation in G-maps defined by Damiand in [3,4]. If needed, this way again illustrates the link between the two structures.

Eventually, in Section 3.2 we will state a definition of simultaneous contraction of cells in a G-map in terms of removals in the dual map, definition which we

prove to be equivalent to the one given by Damiand and Lienhardt in [3]. We finally define in the same way the simultaneous contraction operation in maps and provide a first result (Proposition 23) that justifies this definition using the latter equivalence.

2 Combinatorial maps

2.1 Basic definitions

Definition 1 (*n*-G-map [7]) Let $n \geq 0$, an *n*-G-map is defined as an $n+2$ -tuple $G = (\mathcal{D}, \alpha_0, \dots, \alpha_n)$ where:

- \mathcal{D} is a finite non-empty set of darts;
- $\alpha_0, \dots, \alpha_n$ are involutions on \mathcal{D} (i.e. $\forall i \in \{0, \dots, n\}, \alpha_i^2(b) = b$) such that:
 - $\forall i \in \{0, \dots, n-1\}, \alpha_i$ is an involution without fixed point (i.e. $\forall b \in \mathcal{D}, \alpha_i(b) \neq b$);
 - $\forall i \in \{0, \dots, n-2\}, \forall j \in \{i+2, \dots, n\}, \alpha_i \alpha_j$ is an involution.

If α_n is an involution without fixed point, G is said to be without boundaries or closed. In the following we only consider closed *n*-G-maps with $n \geq 2$.

Remark 1 For any $i, j \in \{0, \dots, n\}$ such that $j \geq i+2$, the permutation $\alpha_i \alpha_j$ is an involution. Therefore, in any *n*-G-map we have:

$$\forall i \in \{0, \dots, n-2\}, \forall j \in \{i+2, \dots, n\}, \alpha_i \alpha_j = \alpha_j \alpha_i$$

Indeed, if $\alpha_i \alpha_j \alpha_i \alpha_j = 1_{\mathcal{D}}$, then $\alpha_i \alpha_j \alpha_i = \alpha_j^{-1} = \alpha_j$ and $\alpha_i \alpha_j = \alpha_j \alpha_i^{-1} = \alpha_j \alpha_i$.

Definition 2 (*n*-map [7]) An *n*-map ($n \geq 1$) is defined as an $(n+1)$ -tuple $M = (\mathcal{D}, \delta_0, \dots, \delta_{n-1})$ such that:

- \mathcal{D} is a finite non-empty set of darts;
- $\delta_0, \dots, \delta_{n-2}$ are involutions on \mathcal{D} and δ_{n-1} is a permutation on \mathcal{D} such that
 - $\forall i \in \{0, \dots, n-2\}, \forall j \in \{i+2, \dots, n\}, \delta_i \delta_j$ is an involution.

Definition 3 (Orbit) Let $\Phi = \{\phi_1, \dots, \phi_k\}$ be a set of permutations on \mathcal{D} (a set of darts). We denote by $\langle \Phi \rangle$ the permutation group generated by Φ , i.e. the set of permutations obtained by any composition and inversion of permutations contained in Φ . The orbit of a dart $d \in \mathcal{D}$ relatively to Φ is defined by $\langle \Phi \rangle(d) = \{\phi(d) \mid \phi \in \langle \Phi \rangle\}$. Furthermore, we extend this notation to the empty set by defining $\langle \emptyset \rangle$ as the identity map.

Definition 4 (Connected component) Let $M = (\mathcal{D}, \gamma_0, \dots, \gamma_{n-1})$ be an

n -map (resp. $G = (\mathcal{D}, \alpha_0, \dots, \alpha_n)$ be an n -G-map). A subset \mathcal{D}' of \mathcal{D} is called a connected component of M (resp. G) if $\mathcal{D}' = \langle \gamma_0, \dots, \gamma_{n-1} \rangle (d)$ (resp. $\mathcal{D}' = \langle \alpha_0, \dots, \alpha_{n-1} \rangle (d)$) for some dart $d \in \mathcal{D}'$.

An n -map may be associated to an n -G-map, as stated by the next definition. In this paper, we use this direct link between the two structures to show that the removal operation we introduce for maps is properly defined (Section 3.1). For that purpose, we notably use the fact that a removal operation (as defined by Damiand and Lienhardt) in a G-map has a counterpart (according to our definition) in its associated map and vice versa.

Definition 5 (Map of the hypervolumes) Let $G = (\mathcal{D}, \alpha_0, \dots, \alpha_n)$ be an n -G-map ($n \geq 1$). The n -map $HV = (\mathcal{D}, \delta_0 = \alpha_n \alpha_0, \dots, \delta_{n-1} = \alpha_n \alpha_{n-1})$ is called the map of the hypervolumes of G .

Lienhardt [8] proved that if the n -G-map G is orientable, HV has two connected components. In the following we only consider orientable n -G-maps and assume that an arbitrary component of the map HV is chosen.

Definition 6 (Dual and inverse) Let $G = (\mathcal{D}, \alpha_0, \dots, \alpha_n)$ be an n -G-map and let $M = (\mathcal{D}, \delta_0, \dots, \delta_{n-1})$ be an n -map.

- The dual of G , denoted by \overline{G} , is defined by:

$$\overline{G} = (\mathcal{D}, \alpha_n, \alpha_{n-1}, \dots, \alpha_0)$$

- The dual and the inverse of M are respectively defined by:

$$\overline{M} = (\mathcal{D}, \delta_0^{-1}, \delta_0^{-1} \delta_{n-1}, \dots, \delta_0^{-1} \delta_1)$$

$$= (\mathcal{D}, \delta_0, \delta_0 \delta_{n-1}, \dots, \delta_0 \delta_1)$$

$$M^{-1} = (\mathcal{D}, \delta_0, \dots, \delta_{n-2}, \delta_{n-1}^{-1})$$

Note that we also have $M^{-1} = (\mathcal{D}, \delta_0^{-1}, \dots, \delta_{n-2}^{-1}, \delta_{n-1}^{-1})$ since $(\delta_i)_{i \in \{0, \dots, n-2\}}$ is an involution.

Proposition 1 If we consider the function HV which maps each n -G-map G to an n -map of the hypervolumes $HV(G)$. We have if $n > 1$:

$$\overline{HV(G)} = HV(\overline{G}).$$

In other words the following diagram commutes:

$$\begin{array}{ccc} G & \xrightarrow{\text{dual}} & \overline{G} \\ HV \downarrow & & \downarrow HV \\ M & \xrightarrow{\text{dual}} & \overline{M} \end{array}$$

Proof:

$$G = (\mathcal{D}, \alpha_0, \dots, \alpha_n)$$

$$\begin{array}{l|l} HV(G) = (\mathcal{D}, \alpha_n \alpha_0, \dots, \alpha_n \alpha_{n-1}) & \overline{G} = (\mathcal{D}, \alpha_n, \dots, \alpha_0) \\ \hline \overline{HV(G)} = (\mathcal{D}, \alpha_0 \alpha_n, \dots, \alpha_0 \alpha_1) & HV(\overline{G}) = (\mathcal{D}, \alpha_0 \alpha_n, \dots, \alpha_0 \alpha_1) \end{array}$$

Indeed, since $n > 1$, $\alpha_n \alpha_0 = \alpha_0 \alpha_n$ and $\forall i \in \{1, \dots, n-1\}$, $\alpha_n \alpha_0 \alpha_n \alpha_i = \alpha_0 \alpha_n \alpha_n \alpha_i = \alpha_0 \alpha_i$. \square

Proposition 2 (Associated maps of an n -G-map [7]) *The two n -maps associated to an n -G-map $G = (\mathcal{D}, \alpha_0, \dots, \alpha_n)$ are defined as:*

$$M_1 = HV(G) = (\mathcal{D}, \alpha_n \alpha_0, \alpha_n \alpha_1, \dots, \alpha_n \alpha_{n-1}) \stackrel{not.}{=} (\mathcal{D}, \gamma_0, \dots, \gamma_{n-1})$$

$$M_2 = \overline{M_1} = HV(\overline{G}) = (\mathcal{D}, \alpha_0 \alpha_n, \alpha_0 \alpha_{n-1}, \dots, \alpha_0 \alpha_1) \stackrel{not.}{=} (\mathcal{D}, \overline{\gamma}_0, \dots, \overline{\gamma}_{n-1})$$

Since there is a one-to-one correspondence between i -cells¹ of M_1 and $(n-i)$ -cells of $M_2 = \overline{M_1}$, and since there is a direct link between the subscripts of the permutations of a map and the way cells are defined, it is convenient to denote² $(\mathcal{D}, \overline{\gamma}_0, \dots, \overline{\gamma}_{n-1}) \stackrel{not.}{=} (\mathcal{D}, \beta_n, \dots, \beta_1)$.

Moreover the permutations $(\beta_i)_{i \in \{1, \dots, n\}}$ and $(\gamma_i)_{i \in \{0, \dots, n-1\}}$ are related by the following relationships ($n \geq 2$):

$$\gamma_0 = \beta_n \text{ and } \forall i \in \{1, \dots, n-1\} \begin{cases} \gamma_i = \beta_n \beta_i \\ \beta_i = \gamma_0 \gamma_i \end{cases}$$

Proof: From Definition 6 $\overline{M_2} = (\mathcal{D}, \beta_n, \beta_n \beta_1, \dots, \beta_n \beta_{n-1})$. Since $\overline{M_2} = \overline{\overline{M_1}} = M_1$, we have $\gamma_0 = \beta_n$ and $\forall i \in \{1, \dots, n-1\}$, $\gamma_i = \beta_n \beta_i$.

In the same way, we have $\overline{M_1} = (\gamma_0, \gamma_0 \gamma_{n-1}, \dots, \gamma_0 \gamma_1)$. We also have by Proposition 1, $\overline{M_1} = \overline{HV(G)} = HV(\overline{G}) = M_2$. Therefore:

$$\beta_n = \gamma_0 \text{ and } \forall i \in \{1, \dots, n-1\} \beta_i = \gamma_0 \gamma_i$$

\square

The two maps M_1 and M_2 associated to an n -G-map G are respectively defined as the maps of the hypervolumes of G and \overline{G} . However, whenever the reference

¹ Cells are formally defined in subsection 2.3.

² These notation are also used for example in [2].

to the n -G-map will not be required we will simply consider that we have two dual maps describing a same partition of the space. The equivalence between these two representations is illustrated in Fig. 1 where the 2-G-map G is the triple $(\mathcal{D} = \mathcal{D}_1 \cup \mathcal{D}_2, \gamma_0, \gamma_1)$ with

$$\mathcal{D}_1 = \{1, 2, 3, 4, 5, 6\}, \mathcal{D}_2 = \{-1, -2, -3, -4, -5, -6\}$$

$$\alpha_0 = (1, -1)(2, -2)(3, -3)(4, -4)(5, -5)(6, -6)$$

$$\alpha_1 = (-1, -2)(2, -1)(3, -4)(4, -3)(5, -6)(6, -5)$$

$$\alpha_2 = (1, -6)(2, -3)(3, -2)(4, -5)(5, -4)(6, -1)$$

The 2-map $HV(G)$ is $(\mathcal{D}_1, \gamma_0, \gamma_1)$ where

$$\gamma_0 = (1, 6)(2, 3)(4, 5)(-1, -6)(-2, -3)(-4, -5)$$

$$\gamma_1 = (1, 5, 3)(2, 4, 6)(-2, -4, -6)(-1, -5, -3)$$

The 2-map $HV(\bar{G})$ is $(\mathcal{D}_2, \beta_2, \beta_1)$ where

$$\beta_2 = \gamma_0$$

$$\beta_1 = (1, 2)(3, 4)(5, 6)(-1, -2)(-3, -4)(-5, -6)$$

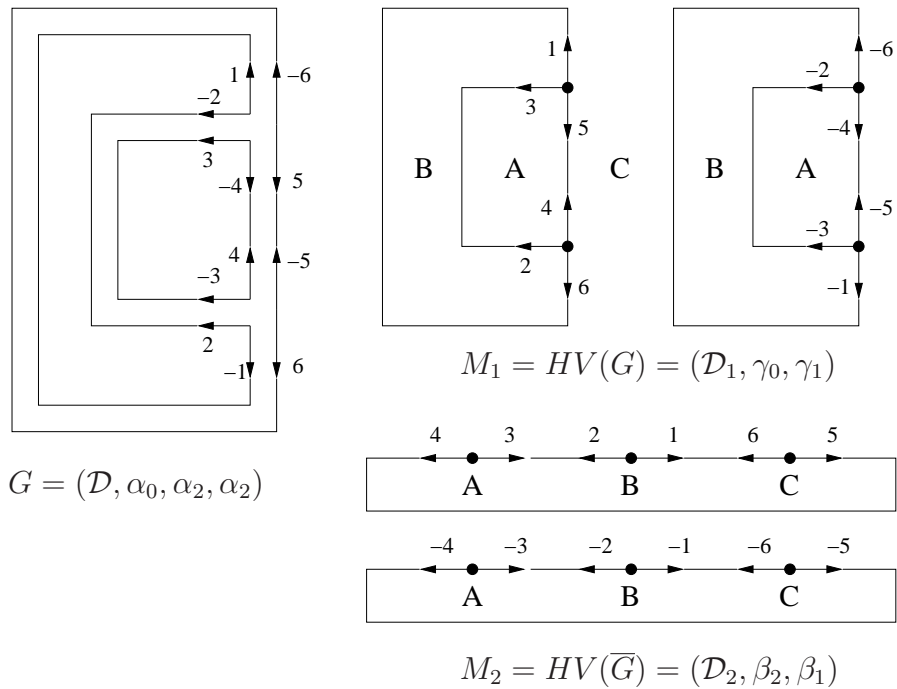

Fig. 1. A closed 2-G-map G (left). The 2-maps $HV(G)$ and $HV(\bar{G})$ (right).

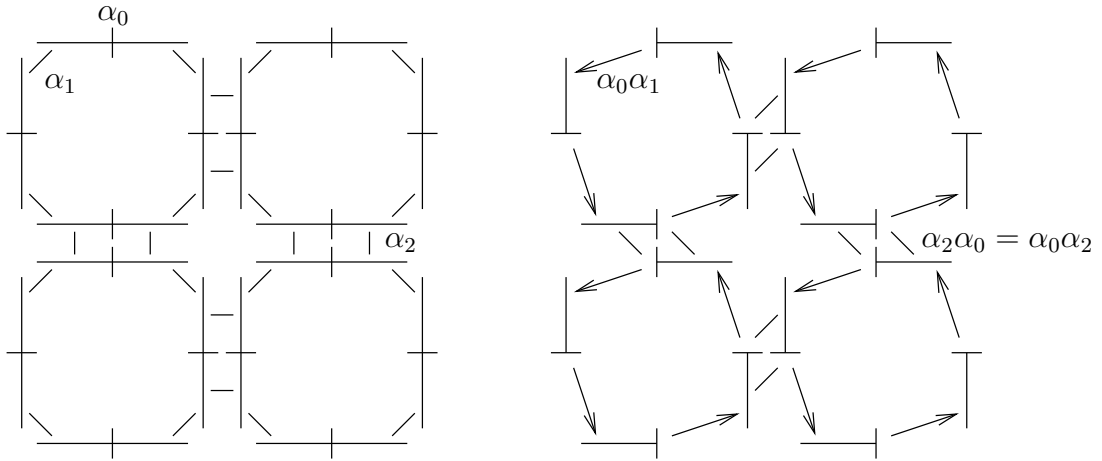

Fig. 2. A part of a closed 2-G-map G (left) and a part of a connected component of the associated n -map $M_2 = HV(\overline{G})$ (right).

2.2 From maps to G -maps and vice versa

We first define the notion of an n -G-map associated to a given n -map. We need a precise construction scheme of the associated G -map, since Lienhard's Theorem 4 [7] only stated the existence of such a G -map.

Definition 7 Let $M = (\mathcal{D}, \gamma_0, \dots, \gamma_{n-1})$ be an n -map. We denote by $AG(M)$ the $(n+1)$ -tuple

$$(\tilde{\mathcal{D}}, \alpha_0, \alpha_1, \dots, \alpha_n)$$

where

- $\tilde{\mathcal{D}} = \mathcal{D} \cup \mathcal{D}'$, where \mathcal{D}' is a finite set with the same cardinal as \mathcal{D} ,
- σ is a one-to-one correspondance between \mathcal{D} and \mathcal{D}' .
- α_i is defined for $i \in \{0, \dots, n-2\}$ by:

$$\alpha_i : \tilde{\mathcal{D}} \longrightarrow \tilde{\mathcal{D}}$$

$$d \longmapsto \begin{cases} d\gamma_i\sigma & \text{if } d \in \mathcal{D} \\ d\sigma^{-1}\gamma_i & \text{if } d \in \mathcal{D}' \end{cases}$$

- α_{n-1} is defined by:

$$\alpha_{n-1} : \tilde{\mathcal{D}} \longrightarrow \tilde{\mathcal{D}}$$

$$d \longmapsto \begin{cases} d\gamma_{n-1}^{-1}\sigma & \text{if } d \in \mathcal{D} \\ d\sigma^{-1}\gamma_{n-1} & \text{if } d \in \mathcal{D}' \end{cases}$$

- α_n is defined by:

$$\alpha_n : \tilde{\mathcal{D}} \longrightarrow \tilde{\mathcal{D}}$$

$$d \longmapsto \begin{cases} d\sigma & \text{if } d \in \mathcal{D} \\ d\sigma^{-1} & \text{if } d \in \mathcal{D}' \end{cases}$$

Remark 2 Any map α_i of Definition 7 satisfies:

$$\begin{aligned} \alpha_{i|\mathcal{D}} : \mathcal{D} &\longrightarrow \mathcal{D}' \\ \alpha_{i|\mathcal{D}'} : \mathcal{D}' &\longrightarrow \mathcal{D} \end{aligned} \tag{1}$$

Furthermore, $\alpha_{i|\mathcal{D}}$ and $\alpha_{i|\mathcal{D}'}$ are both one-to-one correspondances, as the composition of bijective maps for $i < n$, and from the very definition of α_n .

Proposition 3 Let $M = (\mathcal{D}, \gamma_0, \dots, \gamma_{n-1})$ be an n -map and $G = AG(M) = (\tilde{\mathcal{D}} = \mathcal{D} \cup \mathcal{D}', \alpha_0, \dots, \alpha_n)$. We have $HV(G)|_{\mathcal{D}'} \simeq M^{-1}$.

Proof:

□

Lemma 1 If $M = (\mathcal{D}, \gamma_0, \dots, \gamma_{n-1})$ is an n -map and $AG(M) = (\tilde{\mathcal{D}}, \alpha_0, \dots, \alpha_n)$. For all $i \in \{0, \dots, n-1\}$ we have $(\alpha_n \alpha_i)|_{\mathcal{D}} = \gamma_i$. We also have $(\alpha_0 \alpha_n)|_{\mathcal{D}} = \gamma_0$ and for all $i \in \{1, \dots, n-1\}$ and $(\alpha_0 \alpha_i)|_{\mathcal{D}} = \gamma_0 \gamma_i$.

Proof: This comes from the very definition of the involutions α_i , $i \in \{0, \dots, n\}$ (Definition 7). Indeed, let d be a dart of \mathcal{D} , we have $d\alpha_j \in \mathcal{D}'$ for all $j \in \{0, \dots, n\}$.

If $i \in \{0, \dots, n-1\}$, by Definition 7 we obtain that $d\alpha_n \alpha_i = d\sigma\sigma^{-1}\gamma_i = d\gamma_i$. We also have $d\alpha_0 \alpha_n = d\gamma_0\sigma\sigma^{-1} = d\gamma_0$. In the last case, if $i \in \{1, \dots, n-1\}$ we have $d\alpha_0 \alpha_i = d\gamma_0\sigma\sigma^{-1}\gamma_i = d\gamma_0\gamma_i$. □

Proposition 4 For any n -map M , $AG(M)$ is an n - G -map.

Proof: We show that $AG(M)$ satisfies the properties of G -maps (Definition 1). The set $\tilde{\mathcal{D}}$ is indeed finite and non-empty, so we need to check that the applications α_i from \mathcal{D}' to \mathcal{D} are involutions that satisfy the conditions given by the definition.

For $i \in \{0, \dots, n\}$, following Remark 2 and the fact:

- $\mathcal{D} \cap \mathcal{D}' = \emptyset$, and
- the maps $\alpha_{i|\mathcal{D}}$ and $\alpha_{i|\mathcal{D}'}$ are one-to-one

we conclude that α_i is one-to-one. Indeed, if $d_1\alpha_i = d_2\alpha_i$ for $d_1, d_2 \in \tilde{\mathcal{D}}$, it follows from (1) that either $\{d_1, d_2\} \subset \mathcal{D}$ or $\{d_1, d_2\} \subset \mathcal{D}'$. In both cases, it implies that $d_1 = d_2$ since $\alpha_i|_{\mathcal{D}}$ (resp. $\alpha_i|_{\mathcal{D}'}$) is a one-to-one map.

Now, let $d \in \tilde{\mathcal{D}} = \mathcal{D} \cup \mathcal{D}'$. Either $d \in \mathcal{D}$ or $d \in \mathcal{D}'$. In either case, by (1) and the fact that $\alpha_i|_{\mathcal{D}}$ and $\alpha_i|_{\mathcal{D}'}$ are onto, there exists $b \in \tilde{\mathcal{D}}$ such that $d = b\alpha_i$. The map α_i is therefore onto. (If $i < n - 1$ we have $b = d\gamma_i\sigma$ if $d \in \mathcal{D}$, $b = d\sigma\gamma_i$ if $d \in \mathcal{D}'$. For $i = n - 1$ we have $b = d\gamma_{n-1}\sigma$ if $d \in \mathcal{D}$, $b = d\sigma\gamma_{n-1}^{-1}$ if $d \in \mathcal{D}'$. For $i = n$, $b = d\sigma^{-1}$ if $d \in \mathcal{D}$ and $b = d\sigma$ if $d \in \mathcal{D}'$.)

Eventually, the maps α_i are both one-to-one and onto, so they are permutations of $\tilde{\mathcal{D}}$. Let us check that they are involutions.

The map α_n is an involution since $d\alpha_n^2$ is either equal to $d\sigma\sigma^{-1} = d$ (if $d \in \mathcal{D}$) or to $d\sigma^{-1}\sigma = d$ (if $d \in \mathcal{D}'$).

For $i = n - 1$, we have $d\alpha_i^2 = d\gamma_{n-1}^{-1}\sigma\sigma^{-1}\gamma_{n-1}$ or $d\alpha_i = d\sigma^{-1}\gamma_{n-1}\gamma_{n-1}^{-1}\sigma$, which in both cases is equal to d , so α_{n-1} is an involution.

If $i < n - 1$, from the definition of α_i we have $d\alpha_i\alpha_i = d\gamma_i\sigma\sigma^{-1}\gamma_i$ if $d \in \mathcal{D}$ since in this case $d\gamma_i\sigma \in \mathcal{D}'$. Since γ_i , $i < n - 1$ is an involution we obtain $d\alpha_i\alpha_i = d$, so α_i is an involution. (The case when $d \in \mathcal{D}'$ is similar.)

We conclude that all the maps α_i are involutions on $\tilde{\mathcal{D}}$ and is also readily seen from (1) and the fact that $\mathcal{D} \cap \mathcal{D}' = \emptyset$ that they have no fixed points.

Now, we need to check that for all $i \in \{0, \dots, n - 2\}$ and all $j \in \{i + 2, \dots, n\}$, $\alpha_i\alpha_j$ is an involution. For that purpose, we simply follow Definition 7 to build the following table. The two last columns will show that the equality holds for any possible value of i and j .

i	j	$d \in$	$d\alpha_i\alpha_j$	$d\alpha_j\alpha_i$
$< n - 1$	n	\mathcal{D}	$d\gamma_i\sigma\sigma^{-1} = \gamma_i$	$d\sigma\sigma^{-1}\gamma_i = \gamma_i$
$< n - 1$	n	\mathcal{D}'	$d\sigma^{-1}\gamma_i\sigma$	$d\sigma^{-1}\gamma_i\sigma$
$< n - 2$	$n - 1$	\mathcal{D}	$d\gamma_i\sigma\sigma^{-1}\gamma_{n-1} = \gamma_i\gamma_{n-1}$	$d\gamma_{n-1}^{-1}\sigma\sigma^{-1}\gamma_i = \gamma_{n-1}^{-1}\gamma_i$
$< n - 2$	$n - 1$	\mathcal{D}'	$d\sigma^{-1}\gamma_i\gamma_{n-1}^{-1}\sigma$	$d\sigma^{-1}\gamma_{n-1}^{-1}\gamma_i\sigma$
$< n - 3$	$< n - 1$	\mathcal{D}	$d\gamma_i\sigma\sigma^{-1}\gamma_j = \gamma_i\gamma_j$	$d\gamma_j\sigma\sigma^{-1}\gamma_i = \gamma_j\gamma_i$
$< n - 3$	$< n - 1$	\mathcal{D}'	$d\sigma^{-1}\gamma_i\gamma_j\sigma$	$d\sigma^{-1}\gamma_j\gamma_i\sigma$

In the last four rows of the table, we simply use the fact that $\gamma_i\gamma_j = \gamma_j\gamma_i$ (since M is an n -map) to conclude that $d\alpha_i\alpha_j = d\alpha_j\alpha_i$.

The overall conclusion is that $AG(M)$ is indeed an n -G-map. \square

Remark 3 *If $M = (\mathcal{D}, \gamma_0, \dots, \gamma_{n-1})$ is an n -map and \mathcal{D}' is a subset of \mathcal{D} such that for all $d \in \mathcal{D}$ and all $i \in \{0, \dots, n-1\}$, $d\gamma_i \in \mathcal{D}'$; then the map $\gamma_{j|\mathcal{D}'}$ is well defined for all $j \in \{0, \dots, n-1\}$ and the $(n-1)$ -tuple $M' = (\mathcal{D}', \gamma_{0|\mathcal{D}'}, \dots, \gamma_{n-1|\mathcal{D}'})$ satisfies all the conditions of Definition 2.*

Using the next lemma, it follows from the latter remark that M' is a valid n -map if and only if \mathcal{D}' is the union of connected components of M , which will lead to the notion of an induced sub-map (Definition 8).

Lemma 2 *Let $M = (\mathcal{D}, \gamma_0, \dots, \gamma_{n-1})$ be an n -map and \mathcal{D}' be a subset of \mathcal{D} . The two following properties are equivalent:*

- i) \mathcal{D}' is a union of connected components of M ;*
- ii) $\forall d \in \mathcal{D}', \forall i \in \{0, \dots, n-1\}, d\gamma_i \in \mathcal{D}'$.*

Proof: ($i \Rightarrow ii$) since $d\gamma_i$ belongs to the same connected component of M as d , thus it belongs to \mathcal{D}' if $d \in \mathcal{D}'$.

($ii \Rightarrow i$) Let \mathcal{R} be the relation on \mathcal{D}' defined by

$$d\mathcal{R}d' \Leftrightarrow \exists i, d\gamma_i = d'$$

It is readily seen that the reflexive and transitive closure of \mathcal{R} is an equivalence relation whose equivalence classes are orbits in M that use all the permutations γ 's, i.e. they are connected components of M . \square

Definition 8 *Let $M = (\mathcal{D}, \gamma_0, \dots, \gamma_{n-1})$ be an n -map and \mathcal{D}' be a union of connected components of \mathcal{D} . The n -map $(\mathcal{D}', \gamma_{0|\mathcal{D}'}, \dots, \gamma_{n-1|\mathcal{D}'})$, following Remark 3, is called the sub-map of M induced by \mathcal{D}' , which we denote by $M_{|\mathcal{D}'}$.*

In the same way, the notion of a sub-map of an n -G-map is used in the sequel. Its definition is similar.

Proposition 5 *If $M = (\mathcal{D}, \gamma_0, \dots, \gamma_{n-1})$, then we have $M = HV(AG(M))_{|\mathcal{D}}$.*

Proof: Let us consider the following (G-)maps:

- $M = (\mathcal{D}, \gamma_0, \dots, \gamma_{n-1})$
- $G = AG(M) = (\tilde{\mathcal{D}} = \mathcal{D} \cup \mathcal{D}', \alpha_0, \dots, \alpha_n)$
- $HV(G) = (\tilde{\mathcal{D}}, \gamma'_0, \dots, \gamma'_{n-1})$

following Definitions 7 and 5.

We first prove that for all $d \in \mathcal{D}$ and all $i \in \{0, \dots, n-1\}$, $d\gamma'_i = d\gamma_i$. In other word, we prove that $\gamma'_{i|\mathcal{D}} = \gamma_i$. Indeed, by Definition 5 and Definition 7, we have for all $d \in \mathcal{D}$:

$$\begin{aligned} \text{If } i = n-1, \quad d\gamma'_{n-1} &= d\alpha_n\alpha_{n-1} && \text{(Definition 5)} \\ &= d\sigma\sigma^{-1}\gamma_{n-1} = d\gamma_{n-1} && \text{(Definition 7)} \\ \text{if } i < n-1, \quad d\gamma'_i &= d\alpha_n\alpha_i && \text{(Definition 5)} \\ &= d\sigma\sigma^{-1}\gamma_i = d\gamma_i && \text{(Definition 7)} \end{aligned}$$

Let b be a dart of \mathcal{D} . Since M is connected, we have $\mathcal{D} = \langle \gamma_0, \dots, \gamma_{n-1} \rangle (b)$. Since $\gamma'_{i|\mathcal{D}} = \gamma_i$ we deduce that $\mathcal{D} \subset \langle \gamma'_0, \dots, \gamma'_{n-1} \rangle (b)$ in G . On the other hand, if $d \in \langle \gamma'_0, \dots, \gamma'_{n-1} \rangle (b)$, we have $d = b\gamma'_{h_1}\gamma'_{h_2}\dots\gamma'_{h_p}$ for $h_p \in \{0, \dots, n-1\}$, $p \in \mathbb{N}$, and it is readily seen by a recurrence on p that $d = b\gamma_{h_1}\gamma_{h_2}\dots\gamma_{h_p}$, thus $b \in \mathcal{D}$. Eventually, we have $\mathcal{D} = \langle \gamma'_0, \dots, \gamma'_{n-1} \rangle (b)$ (in G).

The orbit $\langle \gamma'_0, \dots, \gamma'_{n-1} \rangle (b)$, which uses all the permutations of $HV(G)$, is then a connected component of $\tilde{\mathcal{D}}$ in G . Therefore, since $\gamma'_{i|\mathcal{D}} = \gamma_i$, we obtain that $M = (\mathcal{D}, \gamma'_{0|\mathcal{D}}, \dots, \gamma'_{n-1|\mathcal{D}})$ is one of the n -maps induced by the connected component $\langle \gamma'_0, \dots, \gamma'_{n-1} \rangle (b)$ of $HV(G)$. In other words, $M = HV(G)_{|\mathcal{D}}$. \square

2.3 Cells in maps

Definition 9 (n -G-maps and cells [7]) Let $G = (\mathcal{D}, \alpha_0, \dots, \alpha_n)$ be an n -G-map ($n \geq 1$). Let us consider $d \in \mathcal{D}$. The i -cell, or cell of dimension i , which contains d is denoted by $\mathcal{C}_i(d)$ and defined by the orbit:

$$\mathcal{C}_i(d) = \langle \alpha_0, \dots, \hat{\alpha}_i, \dots, \alpha_n \rangle (d)$$

where $\hat{\alpha}_i$ denotes the absence of the involution α_i .

Definition 10 (n -maps and cells [7]) Let $M = (\mathcal{D}, \gamma_0, \dots, \gamma_{n-1})$ be an n -map. The i -cell or cell of dimension i (vertex, edges, ...) of M which owns a given dart $d \in \mathcal{D}$ is denoted by $\mathcal{C}_i(d)$ and defined by the orbits:

$$\begin{aligned} \forall i \in \{0, \dots, n-1\} \quad \mathcal{C}_i(d) &= \langle \gamma_0, \dots, \hat{\gamma}_i, \dots, \gamma_{n-1} \rangle (d) \\ \text{For } i = n \quad \mathcal{C}_n(d) &= \langle \gamma_0\gamma_1, \dots, \gamma_0\gamma_{n-1} \rangle (d) \end{aligned}$$

In both an n -map and an n -G-map, two cells \mathcal{C} and \mathcal{C}' with different dimensions will be called *incident* if $\mathcal{C} \cap \mathcal{C}' \neq \emptyset$.

Proposition 6 *The cells of the map $M = (\mathcal{D}, \gamma_0, \dots, \gamma_{n-1})$ may be equivalently expressed according to the permutations of $\overline{M} = (\mathcal{D}, \beta_n, \dots, \beta_1)$ using the following equations:*

$$\begin{aligned} \text{For } i = 0 \quad \mathcal{C}_0(d) &= \langle \beta_1^{-1}\beta_2, \dots, \beta_1^{-1}\beta_n \rangle(d) \\ \forall i \in \{1, \dots, n\} \quad \mathcal{C}_i(d) &= \langle \beta_0, \dots, \hat{\beta}_i, \dots, \beta_n \rangle(d) \end{aligned}$$

Proof: Using Proposition 2, we have for any $i \in \{2, \dots, n-1\}$, $\beta_1^{-1}\beta_i = \gamma_1^{-1}\gamma_0\gamma_0\gamma_i = \gamma_1^{-1}\gamma_i$. Moreover, $\beta_1^{-1}\beta_n = \gamma_1^{-1}\gamma_0\gamma_0 = \gamma_1^{-1}$. We have thus:

- For $i = 0$,

$$\begin{aligned} \mathcal{C}_0(d) &= \langle \gamma_1, \gamma_2, \dots, \gamma_{n-1} \rangle(d) \\ &= \langle \beta_n\beta_1, \beta_n\beta_2, \dots, \beta_n\beta_{n-1} \rangle(d) \\ &= \langle \beta_1^{-1}\beta_n, \beta_n\beta_2, \dots, \beta_n\beta_{n-1} \rangle(d) \\ &= \langle \beta_1^{-1}\beta_n, \beta_1^{-1}\beta_2, \dots, \beta_1^{-1}\beta_{n-1} \rangle(d) \\ &= \langle \beta_1^{-1}\beta_2, \dots, \beta_1^{-1}\beta_{n-1}, \beta_1^{-1}\beta_n \rangle(d) \end{aligned}$$

- For $i \in \{1, \dots, n-1\}$,

$$\begin{aligned} \mathcal{C}_i(d) &= \langle \gamma_0, \gamma_1, \dots, \gamma_{i-1}, \gamma_{i+1}, \dots, \gamma_{n-1} \rangle(d) \\ &= \langle \gamma_0, \gamma_0\gamma_1, \dots, \gamma_0\gamma_{i-1}, \gamma_0\gamma_{i+1}, \dots, \gamma_0\gamma_{n-1} \rangle(d) \\ &= \langle \beta_n, \beta_1, \dots, \beta_{i-1}, \beta_{i+1}, \dots, \beta_{n-1} \rangle(d) \\ &= \langle \beta_1, \dots, \beta_{i-1}, \beta_{i+1}, \dots, \beta_{n-1}, \beta_n \rangle(d) \end{aligned}$$

- For $i = n$,

$$\begin{aligned} \mathcal{C}_n(d) &= \langle \gamma_0\gamma_1, \dots, \gamma_0\gamma_{n-2}, \gamma_0\gamma_{n-1} \rangle(d) \\ &= \langle \beta_1, \dots, \beta_{n-2}, \beta_{n-1} \rangle(d) \end{aligned}$$

□

Definition 11 (Degree and dual degree of a cell) *Let \mathcal{C} be an i -cell in an n -(G -)map, $0 \leq i \leq n$.*

- *The degree of \mathcal{C} is the number of $(i+1)$ -cells incident to \mathcal{C} .*
- *The dual degree of \mathcal{C} is the number of $(i-1)$ -cells incident to \mathcal{C} .*

Property 1 *Following Definition 11, the degree of a cell \mathcal{C} in an n - G -map $G = (\mathcal{D}, \alpha_0, \dots, \alpha_n)$ is precisely the number of sets in the set $\Delta = \{ \langle \hat{\alpha}_{i+1} \rangle(d) \mid d \in \mathcal{C} \}$.*

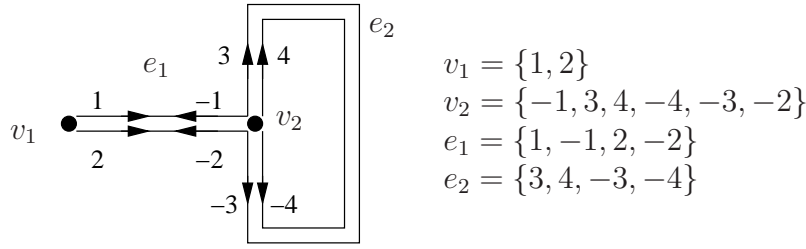

Fig. 3. Degree and local degree: The cell v_2 has a degree 2 and a local degree 3. Dual degree and dual local degree: The cell e_1 has a dual degree and a dual local degree 2, whereas e_2 has a dual degree 1 and a dual local degree 2.

Proof: This characterization is a direct consequence of the definition of the degree (Definition 11) and the one of an $(i + 1)$ -cell in a G-map (Definition 9). \square

Notation 1 Let $(\mathcal{D}, \alpha_0, \dots, \alpha_n)$ be an n -G-map. For $d \in \mathcal{D}$, we denote by $\langle \hat{\alpha}_{k_1}, \hat{\alpha}_{k_2}, \dots, \hat{\alpha}_{k_p} \rangle (d)$, where all the involutions are excluded, the orbit $\langle \Phi \rangle (d)$ where $\Phi = \{\alpha_0, \dots, \alpha_n\} \setminus \{\alpha_{k_1}, \alpha_{k_2}, \dots, \alpha_{k_p}\}$.

Definition 12 (Local degree in G-maps) Let \mathcal{C} be an i -cell in an n -G-map.

- For $i \in \{0, \dots, n - 1\}$, the local degree of \mathcal{C} is the number

$$|\{\langle \hat{\alpha}_i, \hat{\alpha}_{i+1} \rangle (b) \mid b \in \mathcal{C}\}|$$

- For $i \in \{1, \dots, n\}$, the dual local degree of \mathcal{C} is the number

$$|\{\langle \hat{\alpha}_{i-1}, \hat{\alpha}_i \rangle (b) \mid b \in \mathcal{C}\}|$$

The local degree (resp. dual local degree) of an n -cell (resp. a 0-cell) is 0.

More intuitively, the local degree of an i -cell \mathcal{C} is the number of $i + 1$ -cells that locally appear to be incident to \mathcal{C} . It is called *local* because it may be different from the degree since an $i + 1$ -cell may be incident more than once to an i -cell, as illustrated in Figure 3 where the 1-cell e_2 is multi-incident to the 0-cell v_2 .

On the other hand, the dual local degree of an i -cell \mathcal{C} is the number of $(i - 1)$ -cells that appear to be incident to \mathcal{C} . As in the example given in Figure 3 where the edge e_2 locally appears to be bounded by two vertices, as it is always the case for a 1-cell, whereas the darts involved by the orbits considered in Definition 12 all belong to a unique vertex (v_2).

Property 2 The degree of a cell in an n -G-map is greater than zero and less than or equal to its local degree.

Proof: Let \mathcal{C} be an i -cell in an n -G-map and $d \in \mathcal{C}$. Following Definition 9, $\mathcal{C}_{i+1}(d)$ is not empty and $d \in \mathcal{C} \cap \mathcal{C}_{i+1}(d)$. Thus, \mathcal{C} is incident to at least one $(i + 1)$ -cell.

The degree of \mathcal{C} is the number $|\Delta|$ where $\Delta = \left\{ \langle \hat{\alpha}_i \rangle (d) \mid d \in \mathcal{C} \right\}$ (Property 1). By Definition 12, the local degree of \mathcal{C} is the number of sets in the set $\Lambda = \left\{ \langle \hat{\alpha}_{i+1}, \hat{\alpha}_{i+1} \rangle (d) \mid d \in \mathcal{C} \right\}$.

Now, for any dart b of \mathcal{C} we have $\langle \hat{\alpha}_i, \hat{\alpha}_{i+1} \rangle (b) \subset \langle \hat{\alpha}_{i+1} \rangle (b)$ (see the definition of an orbit). Furthermore, for any orbit $\langle \hat{\alpha}_{i+1} \rangle (b')$ distinct from $\langle \hat{\alpha}_{i+1} \rangle (b)$, we have $\langle \hat{\alpha}_i, \hat{\alpha}_{i+1} \rangle (b) \not\subset \langle \hat{\alpha}_{i+1} \rangle (b')$. Indeed, if $\langle \hat{\alpha}_{i+1} \rangle (b) \neq \langle \hat{\alpha}_{i+1} \rangle (b')$, then $b \notin \langle \hat{\alpha}_{i+1} \rangle (b')$ while $b \in \langle \hat{\alpha}_i, \hat{\alpha}_{i+1} \rangle (b)$.

It follows that the above inclusion relation induces a map from Λ to Δ which is onto, hence $|\Delta| \leq |\Lambda|$. \square

Property 3 (Cell with local degree 1) *An i -cell \mathcal{C} in an n -G-map is of local degree 1 if and only if for all $d \in \mathcal{C}$, $d\alpha_{i+1} \in \langle \hat{\alpha}_i, \hat{\alpha}_{i+1} \rangle (d)$.*

Proof: If \mathcal{C} is of local degree 1, we have $\left| \left\{ \langle \hat{\alpha}_i, \hat{\alpha}_{i+1} \rangle (d) \mid d \in \mathcal{C} \right\} \right| = 1$. It follows that $\langle \hat{\alpha}_i, \hat{\alpha}_{i+1} \rangle (d) = \mathcal{C}$ for all $d \in \mathcal{C}$. From the definition of an i -cell, $d\alpha_{i+1} \in \mathcal{C}$ so that $d\alpha_{i+1} \in \langle \hat{\alpha}_i, \hat{\alpha}_{i+1} \rangle (d)$, hence the ‘‘only if’’ part.

If $d\alpha_{i+1} \in \langle \hat{\alpha}_i, \hat{\alpha}_{i+1} \rangle (d)$ for all $d \in \mathcal{C}$, it is readily seen that

$$\forall b \in \mathcal{C}, \langle \hat{\alpha}_i, \hat{\alpha}_{i+1} \rangle (b) = \langle \hat{\alpha}_i \rangle (b)$$

Indeed, in $b' = b\alpha_{k_1} \dots \alpha_{k_p} \in \langle \hat{\alpha}_i \rangle (b)$ any involution $\alpha_{k_j} = \alpha_{i+1}$ may be replaced by a composition of involutions in $\langle \hat{\alpha}_i, \hat{\alpha}_{i+1} \rangle$ since $b\alpha_{k_1} \dots \alpha_{k_{p-1}} \in \mathcal{C}$. Thus we have $\langle \hat{\alpha}_i \rangle (b) \subset \langle \hat{\alpha}_i, \hat{\alpha}_{i+1} \rangle (b)$, and obviously $\langle \hat{\alpha}_i, \hat{\alpha}_{i+1} \rangle (b) \subset \langle \hat{\alpha}_i \rangle (b)$. Hence the ‘‘if’’ part. \square

The following definition for a cell \mathcal{C} with a local degree 2 is given in [5].

Definition 13 (Cell with local degree 2 [5])

- For all $i \in \{0, \dots, n - 2\}$, an i -cell \mathcal{C} is of local degree two if

$$\forall b \in \mathcal{C}, b\alpha_{i+1}\alpha_{i+2} = b\alpha_{i+2}\alpha_{i+1}$$

- For all $i \in \{2, \dots, n\}$, an i -cell \mathcal{C} is of dual local degree two if

$$\forall b \in \mathcal{C}, b\alpha_{i-1}\alpha_{i-2} = b\alpha_{i-2}\alpha_{i-1}$$

In fact, according to the above definition, the 0-cell v_1 in Figure 3 would have a local degree of 2, although this is obviously not what was meant by Grasset

in her definition. Beside the fact that Grasset's definition does not distinguish cells with local degree 1 from cells with local degree 2, it is also far more restrictive than our definition for a cell with local degree 2 (Definition 12).

However, Grasset's definition was intended to characterize cells that could be removed from a G-map, producing a valid new G-map. To that extent, and except for the case of cells with a local degree 1, it is a good criterion but again not a proper definition for cells with local degree 2. (The removal operation in maps is the purpose of Section 3).

For clarity, we introduce here a criterion for a cell to be *removable*. This criterion may be expressed as a modified version of Grasset's definition for the local degree 2 that actually excludes cells with a local degree of 1. But we also provide an equivalent characterization, in terms of several conditions among which appears clearly the exact notion of local degree 2 (Theorem 1).

Lemma 3 *For any $i \in \{0, \dots, n-2\}$, and any i -cell \mathcal{C} if:*

- i) $\exists b \in \mathcal{C}$, $b\alpha_{i+1} \notin \langle \hat{\alpha}_i, \hat{\alpha}_{i+1} \rangle(b)$, and*
- ii) $\forall b \in \mathcal{C}$, $b\alpha_{i+1}\alpha_{i+2} = b\alpha_{i+2}\alpha_{i+1}$*

then \mathcal{C} is of local degree 2.

Proof: Let \mathcal{C} be an i -cell that satisfies conditions *i)* and *ii)*. Let $b \in \mathcal{C}$ be a dart such that $b\alpha_{i+1} \notin \langle \hat{\alpha}_i, \hat{\alpha}_{i+1} \rangle(b)$, following condition *ii)*. Eventually, let d be any other dart of \mathcal{C} .

From the definition of a cell, we have $d = b\alpha_{k_1}\alpha_{k_2}\dots\alpha_{k_p}$ with $k_h \neq i$ for all $h \in \{1, \dots, p\}$.

For all $h > 1$ such that $k_h = i+1$, let us consider $d' = b\alpha_{k_1}\dots\alpha_{k_{h-2}}$. If $k_{h-1} = i+2$ then from condition *ii)* we know that $d'\alpha_{k_{h-1}}\alpha_{k_h} = d'\alpha_{k_h}\alpha_{k_{h-1}}$. In the remaining cases ($k_{h-1} \notin \{i, i+2\}$) we have either $|k_h - k_{h-1}| > 1$ or $k_h = k_{h-1}$, so that in both cases $d'\alpha_{k_{h-1}}\alpha_{k_h} = d'\alpha_{k_h}\alpha_{k_{h-1}}$ (see Definition 1 when $|k_h - k_{h-1}| > 1$). In other words, α_{i+1} always commutes with its predecessor in the sequence of compositions $\alpha_{k_1}\alpha_{k_2}\dots\alpha_{k_p}$.

It follows that we may write $d = b\alpha_{i+1}^r\alpha_{k'_1}\alpha_{k'_2}\dots\alpha_{k'_q}$ with $k'_h \notin \{i, i+1\}$ for all $h \in \{1, \dots, q\}$ and $r \in \mathbb{N}$. Eventually, if r is even we have $d = (b)\alpha_{k'_1}\alpha_{k'_2}\dots\alpha_{k'_q}$ and if r is odd, $d = (b\alpha_{i+1})\alpha_{k'_1}\alpha_{k'_2}\dots\alpha_{k'_q}$. In other words,

$$d \in \langle \hat{\alpha}_i, \hat{\alpha}_{i+1} \rangle(b)$$

or

$$d \in \langle \hat{\alpha}_i, \hat{\alpha}_{i+1} \rangle(b\alpha_{i+1}).$$

Since $b\alpha_{i+1} \notin \langle \hat{\alpha}_i, \hat{\alpha}_{i+1} \rangle(b)$, it follows that the two above orbits are distinct. As any dart $d \in \mathcal{C}$ belongs to one of them, they form a partition of \mathcal{C} and the local degree of \mathcal{C} is 2 according to Definition 12. \square

At this point, we introduce the notion of a regular cell that will help us to clarify (with Theorem 1) the link between the proper notion of a local degree 2 and the one of cells that may indeed be removed while preserving the properties of a G-map.

Definition 14 (Regular cell) *An i -cell ($i \leq n - 2$) in an n -G-map is said to be regular if it satisfies the two following conditions:*

- a) $\forall d \in \mathcal{C}$, $d\alpha_{i+1}\alpha_{i+2} = d\alpha_{i+2}\alpha_{i+1}$ or $d\alpha_{i+1}\alpha_{i+2} \notin \langle \hat{\alpha}_i, \hat{\alpha}_{i+1} \rangle(d\alpha_{i+2}\alpha_{i+1})$,
and
- b) $\forall b \in \mathcal{C}$, $b\alpha_{i+1} \notin \langle \hat{\alpha}_i, \hat{\alpha}_{i+1} \rangle(b)$

Lemma 4 *Let G be an n -G-map and \mathcal{C} be an i -cell of G for $i \in \{0, \dots, n-2\}$. If both conditions i) and ii) below are satisfied,*

- i) $\exists b \in \mathcal{C}$, $b\alpha_{i+1} \notin \langle \hat{\alpha}_i, \hat{\alpha}_{i+1} \rangle(b)$, and
- ii) $\forall b \in \mathcal{C}$, $b\alpha_{i+1}\alpha_{i+2} = b\alpha_{i+2}\alpha_{i+1}$

then \mathcal{C} is regular.

Proof: The proposition a) of Definition 14 is trivial from ii).

Let us consider a dart b which satisfies i) and an arbitrary dart $d \in \mathcal{C}$. Using Lemma 4, $d \in \langle \hat{\alpha}_i, \hat{\alpha}_{i+1} \rangle(b)$ or $d \in \langle \hat{\alpha}_i, \hat{\alpha}_{i+1} \rangle(b\alpha_{i+1})$ with:

$$\langle \hat{\alpha}_i, \hat{\alpha}_{i+1} \rangle(b) \neq \langle \hat{\alpha}_i, \hat{\alpha}_{i+1} \rangle(b\alpha_{i+1}).$$

Let us suppose that $d \in \langle \hat{\alpha}_i, \hat{\alpha}_{i+1} \rangle(b)$. We have thus $d = b\alpha_{j_1} \dots \alpha_{j_p}$ with $j_k \in \{0, \dots, n\} - \{i, i+1\}$ for all k .

- If $j_k \neq i+2$, for any $k \in \{1, \dots, p\}$ then α_{i+1} commutes with any α_{j_k} , $k \in \{1, \dots, p\}$ and we have:

$$d\alpha_{i+1} = b\alpha_{i+1}\alpha_{j_1} \dots \alpha_{j_p}.$$

- Otherwise, let us consider the greatest index h such that $j_h = i+2$. By definition of h we have:

$$\begin{aligned} d\alpha_{i+1} &= b\alpha_{j_1} \dots \alpha_{j_p}\alpha_{i+1} \\ &= b\alpha_{j_1} \dots \alpha_{j_{h-1}}\alpha_{i+2}\alpha_{i+1}\alpha_{j_{h+1}} \dots \alpha_{j_p} \end{aligned}$$

with both sequences $\alpha_{j_1} \dots \alpha_{j_{h-1}}$ and $\alpha_{j_{h+1}} \dots \alpha_{j_p}$ being possibly empty.

Since $b\alpha_{j_1} \dots \alpha_{j_{h-1}}$ belongs to \mathcal{C} we have by *ii*):

$$b\alpha_{j_1} \dots \alpha_{j_{h-1}} \alpha_{i+2} \alpha_{i+1} \alpha_{j_{h+1}} \dots \alpha_{j_p} = b\alpha_{j_1} \dots \alpha_{j_{h-1}} \alpha_{i+1} \alpha_{i+2} \alpha_{j_{h+1}} \dots \alpha_{j_p}$$

This process may be iterated on the sequence $d\alpha_{j_1} \dots \alpha_{j_{h-1}} \alpha_{i+1}$ until α_{i+1} reaches the dart b . We obtain thus finally:

$$d\alpha_{i+1} = b\alpha_{i+1} \alpha_{j_1} \dots \alpha_{j_p}$$

We have thus in both cases $d\alpha_{i+1} \in \langle \hat{\alpha}_i, \hat{\alpha}_{i+1} \rangle (b\alpha_{i+1})$. Since $\langle \hat{\alpha}_i, \hat{\alpha}_{i+1} \rangle (b\alpha_{i+1}) \neq \langle \hat{\alpha}_i, \hat{\alpha}_{i+1} \rangle (b)$ and $d \in \langle \hat{\alpha}_i, \hat{\alpha}_{i+1} \rangle (b)$ by hypothesis we obtain:

$$d\alpha_{i+1} \notin \langle \hat{\alpha}_i, \hat{\alpha}_{i+1} \rangle (d)$$

The same demonstration may be conducted if $d \in \langle \hat{\alpha}_i, \hat{\alpha}_{i+1} \rangle (b\alpha_{i+1})$. \square

Theorem 1 For any $i \in \{0, \dots, n-2\}$, an i -cell \mathcal{C} is a regular cell with local degree 2 if and only if

- i*) $\exists b \in \mathcal{C}$, $b\alpha_{i+1} \notin \langle \hat{\alpha}_i, \hat{\alpha}_{i+1} \rangle (b)$, and
- ii*) $\forall b \in \mathcal{C}$, $b\alpha_{i+1}\alpha_{i+2} = b\alpha_{i+2}\alpha_{i+1}$

Proof: The reverse implication is provided by Lemma 3 (local degree 2) and 4 (regular). Let us show the implication. First, if \mathcal{C} is of local degree 2 it is not of local degree 1 and the property *i*) is provided by Property 3.

Secondly, let us now consider a dart $d \in \mathcal{C}$. We have by condition *b*) of Definition 14 (and the fact that $d\alpha_{i+2} \in \mathcal{C}$):

$$d\alpha_{i+1} \notin \langle \hat{\alpha}_i, \hat{\alpha}_{i+1} \rangle (d) \text{ and } d\alpha_{i+2}\alpha_{i+1} \notin \langle \hat{\alpha}_i, \hat{\alpha}_{i+1} \rangle (d)$$

Therefore if $d\alpha_{i+1} \notin \langle \hat{\alpha}_i, \hat{\alpha}_{i+1} \rangle (d\alpha_{i+2}\alpha_{i+1})$, the three orbits $\langle \hat{\alpha}_i, \hat{\alpha}_{i+1} \rangle (d)$, $\langle \hat{\alpha}_i, \hat{\alpha}_{i+1} \rangle (d\alpha_{i+1})$ and $\langle \hat{\alpha}_i, \hat{\alpha}_{i+1} \rangle (d\alpha_{i+2}\alpha_{i+1})$ are distinct. However, in this case \mathcal{C} would be of local degree at least 3, which contradicts the hypothesis about the local degree 2 of \mathcal{C} . We have thus:

$$d\alpha_{i+1} \in \langle \hat{\alpha}_i, \hat{\alpha}_{i+1} \rangle (d\alpha_{i+2}\alpha_{i+1})$$

which implies that

$$d\alpha_{i+1}\alpha_{i+2} \in \langle \hat{\alpha}_i, \hat{\alpha}_{i+1} \rangle (d\alpha_{i+2}\alpha_{i+1})$$

Using property *a*) given by Definition 14, this last point implies that $d\alpha_{i+1}\alpha_{i+2} = d\alpha_{i+2}\alpha_{i+1}$ which corresponds to *ii*). \square

Definition 15 (Local degree in maps) Let \mathcal{C} be an i -cell in an n -map.

- The local degree of \mathcal{C} is the number

$$\begin{aligned} & \left| \{ \langle \hat{\gamma}_i, \hat{\gamma}_{i+1} \rangle (b) \mid b \in \mathcal{C} \} \right| && \text{if } i \in \{0, \dots, n-2\} \\ & \left| \{ \langle \gamma_0 \gamma_1, \dots, \gamma_0 \gamma_{n-2} \rangle (b) \mid b \in \mathcal{C} \} \right| && \text{if } i = n-1 \end{aligned}$$

- The dual local degree of \mathcal{C} is the number

$$\begin{aligned} & \left| \{ \langle \hat{\gamma}_i, \hat{\gamma}_{i-1} \rangle (b) \mid b \in \mathcal{C} \} \right| && \text{for } i \in \{1, \dots, n-1\} \\ & \left| \{ \langle \gamma_0 \gamma_1, \dots, \gamma_0 \gamma_{n-2} \rangle (b) \mid b \in \mathcal{C} \} \right| && \text{for } i = n \end{aligned}$$

The local degree (resp. dual local degree) of an n -cell (resp. a 0-cell) is 0.

Let us justify the orbits considered in the definition of the local degree when $i \in \{0, \dots, n-2\}$. As for G-maps, we consider the darts that may be reached from d while allowing no change of i -cell (hence $\hat{\gamma}_i$) and no change of $(i+1)$ -cell (hence $\hat{\gamma}_{i+1}$). In the case when $i = n-1$, preventing any change of $(n-1)$ -cell means that the allowed involutions are in $\{\gamma_0, \dots, \gamma_{n-2}\}$, and preventing any change of n -cell means, according to Definition 10, that the set of allowed involutions is $\{\gamma_0 \gamma_1, \dots, \gamma_0 \gamma_{n-1}\}$. Overall, only the involution $\gamma_0 \gamma_{n-1}$ of the latter set is not allowed by the first one, therefore we obtain the orbit that must be considered, i.e. $\langle \gamma_0 \gamma_1, \dots, \gamma_0 \gamma_{n-2} \rangle$.

Definition 16 (Regular cell in n -maps) A cell in an n -map is said to be regular if it satisfies the two conditions a) and b) below:

- a) If $i < n-3$, for all $d \in \mathcal{C}$ we have:

$$d\gamma_{i+1}\gamma_{i+2} = d\gamma_{i+2}\gamma_{i+1} \text{ or } d\gamma_{i+1}\gamma_{i+2} \notin \langle \hat{\gamma}_i, \hat{\gamma}_{i+1} \rangle (d\gamma_{i+2}\gamma_{i+1})$$

- If $i = n-3$, for all $d \in \mathcal{C}$ we have:

$$\begin{aligned} d\gamma_{n-2}\gamma_{n-1} &= d\gamma_{n-1}^{-1}\gamma_{n-2} \text{ and } d\gamma_{n-2}\gamma_{n-1}^{-1} = d\gamma_{n-1}\gamma_{n-2}, \text{ or} \\ d\gamma_{n-2} &\notin \left(\langle \hat{\gamma}_{n-3}, \hat{\gamma}_{n-2} \rangle (d\gamma_{n-1}^{-1}\gamma_{n-2})\gamma_{n-1}^{-1} \cup \langle \hat{\gamma}_{n-3}, \hat{\gamma}_{n-2} \rangle (d\gamma_{n-1}\gamma_{n-2})\gamma_{n-1} \right) \end{aligned}$$

- If $i = n-2$, for all $d \in \mathcal{C}$ we have:

$$\begin{aligned} d\gamma_{n-1}^{-1} &= d\gamma_{n-1}, \text{ or} \\ d\gamma_{n-1}^{-1} &\notin \langle \gamma_1, \dots, \gamma_{n-3} \rangle (d\gamma_{n-1}) \text{ and } d\gamma_{n-1} \notin \langle \gamma_1, \dots, \gamma_{n-3} \rangle (d\gamma_{n-1}^{-1}) \end{aligned}$$

- b) If $i < n-2$, for all $b \in \mathcal{C}$ we have:

$$b\gamma_{i+1} \notin \langle \hat{\gamma}_i, \hat{\gamma}_{i+1} \rangle (b)$$

If $i = n - 2$, for all $b \in \mathcal{C}$ we have:

$$\{b\gamma_{n-1}, b\gamma_{n-1}^{-1}\} \cap \langle \gamma_0, \dots, \gamma_{n-3} \rangle (b) = \emptyset$$

Remark 4 If γ is a permutation of a set S , then for all $s \in S$ there exists $p \in \mathbb{N}$ such that

$$s\gamma = \overbrace{s\gamma^{-1} \dots \gamma^{-1}}^p = s\gamma^{-p}$$

Conversly, for all $s \in S$ there exists $q \in \mathbb{N}$ such that $s\gamma^{-1} = s\gamma^q$.

Notation 2 If \mathcal{D} and \mathcal{D}' are sets, $\sigma : \mathcal{D} \longrightarrow \mathcal{D}'$, and $S \subset \mathcal{D}$, we denote by $S\sigma$ the image of S by σ , i.e.

$$S\sigma = \{\sigma(s) \mid s \in S\}$$

Proposition 7 Let M be an n -map and $\tilde{G} = AG(M)$. If \mathcal{C} is an i -cell of M , then the set $\tilde{\mathcal{C}} = \mathcal{C} \cup \mathcal{C}\sigma$ is an i -cell of \tilde{G} if $i < n$, and $\tilde{\mathcal{C}} = \mathcal{C} \cup \mathcal{C}\gamma_0\sigma$ is an n -cell of \tilde{G} if $i = n$.

Corollary 2 With the notations of Proposition 7 we have:

$$\forall d \in \mathcal{C}, \langle \hat{\alpha}_i \rangle (d) = \tilde{\mathcal{C}}$$

Proof of Proposition 7:

• If $i < n$. We prove that for all $b \in \mathcal{C} \cup \mathcal{C}\sigma$, $\langle \hat{\alpha}_i \rangle (b) = \mathcal{C} \cup \mathcal{C}\sigma = \mathcal{C} \cup \mathcal{C}\alpha_n$. Let us show first that $\langle \hat{\alpha}_i \rangle (b) \subset \mathcal{C} \cup \mathcal{C}\sigma$. Let $b \in \mathcal{C} \cup \mathcal{C}\sigma$ and $d \in \langle \hat{\alpha}_i \rangle (b)$. We have $d = b\alpha_{k_1}\alpha_{k_2} \dots \alpha_{k_p}$ where $p \in \mathbb{N}$ and $k_h \in \{0, \dots, n\} \setminus \{i\}$, $0 \leq h \leq p$. (Note that following Remark 4 we suppose wlog that the sequence $\alpha_{k_1}\alpha_{k_2} \dots \alpha_{k_p}$ does not involve any inverse of an involution.)

We prove by recurrence on p , the length of the sequence $\alpha_{k_1}\alpha_{k_2} \dots \alpha_{k_p}$, that $d \in \mathcal{C} \cup \mathcal{C}\sigma$. First, if $p = 0$ we have $d = b \in \mathcal{C}$ and there is nothing left to prove. Thus, the property holds for $p = 0$.

Now we suppose that the property is satisfied for $p \in \mathbb{N}^*$ and we consider a dart $d = b\alpha_{k_1} \dots \alpha_{k_p}\alpha_{k_{p+1}}$. We denote $b' = b\alpha_{k_1} \dots \alpha_{k_p}$. Since the property is valid for p , we have $b' \in \mathcal{C}$ or $b' \in \mathcal{C}\sigma$.

If $b' \in \mathcal{C}$, we deduce from Definition 7 that

$$b'\alpha_{k_{p+1}} = \begin{cases} b'\gamma_{k_{p+1}}\sigma & \text{if } k_{p+1} < n - 1 \\ b'\gamma_{n-1}^{-1}\sigma & \text{if } k_{p+1} = n - 1 \\ b'\sigma & \text{if } k_{p+1} = n \end{cases}$$

so that in all cases $b'\alpha_{k_{p+1}} \in \langle \hat{\gamma}_i \rangle (d)\sigma$.

If $b' \in \mathcal{C}\sigma$ we have $b' = b''\sigma$ with $b'' \in \mathcal{C}$. Again, following Definition 7 and the fact that $\mathcal{C}\sigma \subset \mathcal{D}'$, we have

$$d = b'\alpha_{k_{p+1}} = b''\sigma\alpha_{k_{p+1}} = \begin{cases} b''\sigma\sigma^{-1}\gamma_{k_{p+1}} = b''\gamma_{k_{p+1}} & \text{if } k_{p+1} < n \\ b''\sigma\sigma^{-1} = b'' & \text{if } k_{p+1} = n \end{cases}$$

so that $b'\alpha_{k_{p+1}} \in \mathcal{C}$ since $b'' \in \mathcal{C}$ and $k_{p+1} \neq i$.

From the two latter cases, we obtain that $b\alpha_{k_1} \dots \alpha_{k_p} \alpha_{k_{p+1}} \in \mathcal{C} \cup \mathcal{C}\sigma$; hence the property is valid for all $p \in \mathbb{N}^*$. We conclude that $\langle \hat{\alpha}_i \rangle(b) \subset \mathcal{C} \cup \mathcal{C}\sigma$.

Now, we have $\mathcal{C} = \langle \hat{\gamma}_i \rangle(b)$. From Lemma 1 we deduce that the orbit

$$\langle \gamma_1, \dots, \hat{\gamma}_i, \dots, \gamma_{n-1} \rangle(b) \text{ in } M$$

is precisely

$$\langle \alpha_n \alpha_0, \dots, \alpha_n \hat{\alpha}_i, \dots, \alpha_n \alpha_{n-1} \rangle(b) \text{ in } AG(M)$$

and since $i < n$ we have

$$\langle \alpha_n \alpha_0, \dots, \alpha_n \hat{\alpha}_i, \dots, \alpha_n \alpha_{n-1} \rangle(b) \subset \langle \alpha_0, \dots, \hat{\alpha}_i, \dots, \alpha_n \rangle(b)$$

Eventually, $\mathcal{C} \subset \langle \hat{\alpha}_i \rangle(b)$. Since $i \neq n$, we immediatly obtain that $\mathcal{C}\sigma = \mathcal{C}\alpha_n \subset \langle \hat{\alpha}_i \rangle(b)$. Therefore, $\mathcal{C} \cup \mathcal{C}\sigma \subset \langle \hat{\alpha}_i \rangle(b)$ and we conclude that $\langle \hat{\alpha}_i \rangle(b) = \mathcal{C} \cup \mathcal{C}\sigma$.

• If $i = n$. Let $b \in \mathcal{C}$, we prove that $\langle \hat{\alpha}_n \rangle(b) = \mathcal{C} \cup \mathcal{C}\gamma_0\sigma$ where

$$\mathcal{C} = \langle \gamma_0 \gamma_1, \dots, \gamma_0 \gamma_{n-1} \rangle(b)$$

($\langle \hat{\alpha}_n \rangle(b) \subset \mathcal{C} \cup \mathcal{C}\gamma_0\sigma$) Let $d \in \langle \hat{\alpha}_n \rangle(b)$. We have $d = b\alpha_{k_1} \dots \alpha_{k_p}$ for $p \in \mathbb{N}$, with $k_h \in \{0, \dots, n-1\}$ for $1 \leq h \leq p$.

We prove by recurrence on p , the length of the sequence $\alpha_{k_1} \dots \alpha_{k_p}$, that $d \in \mathcal{C} \cup \mathcal{C}\gamma_0\sigma$. If $p = 0$, we have $d = b \in \mathcal{C}$ and there is nothing left to prove.

Thus, we suppose that the property holds for some $p \in \mathbb{N}$ and we consider a dart $d = b\alpha_{k_1} \dots \alpha_{k_p} \alpha_{k_{p+1}}$. We denote $d' = b\alpha_{k_1} \dots \alpha_{k_p}$, so from the recurrence hypothesis we have $d' \in \mathcal{C} \cup \mathcal{C}\gamma_0\sigma$.

If $d' \in \mathcal{C}$, from Definition 7 we obtain that:

$$- \text{ If } k_{p+1} = 0, d'\alpha_{k_{p+1}} = d'\alpha_0\alpha_n\alpha_n = d'\alpha_n\alpha_0\alpha_n = d'(\gamma_0\sigma) \in \mathcal{C}\gamma_0\sigma.$$

– If $0 < k_{p+1} \leq n - 1$,

$$\begin{aligned}
b\alpha_{k_{p+1}} &= b\alpha_{k_{p+1}}\sigma^{-1}\gamma_0\gamma_0\sigma \\
&= b\alpha_{k_{p+1}}\alpha_n\gamma_0\gamma_0\sigma \\
&= b(\alpha_n\alpha_{k_{p+1}})^{-1}\gamma_0\gamma_0\sigma \\
&= b\gamma_{k_{p+1}}^{-1}\gamma_0\gamma_0\sigma \quad (\text{By Lemma 1}) \\
&= b(\gamma_0\gamma_{k_{p+1}})^{-1}\gamma_0\sigma
\end{aligned}$$

Since $b \in \mathcal{C}$ we have $b(\gamma_0\gamma_{k_1})^{-1} \in \mathcal{C}$, hence $b\alpha_{k_{p+1}} \in \mathcal{C}\gamma_0\sigma$.

If $d' \in \mathcal{C}\gamma_0\sigma$ then $d' = d''\gamma_0\sigma$ for some dart $d'' \in \mathcal{C}$ and we have

$$\begin{aligned}
d'\alpha_{k_{p+1}} &= d''\gamma_0\sigma\alpha_{k_{p+1}} \\
&= d''\gamma_0\sigma\sigma^{-1}\gamma_{k_{p+1}} \quad (\text{since } d''\gamma_0\sigma \in \mathcal{D}' \text{ and } k_{p+1} < n) \\
&= d''\gamma_0\gamma_{k_{p+1}}
\end{aligned}$$

Since $d'' \in \mathcal{C}$, we obtain that $d'\alpha_{k_{p+1}} \in \mathcal{C} = \langle \gamma_0\gamma_1, \dots, \gamma_0\gamma_{n-1} \rangle (b)$.

Eventually, either $d \in \mathcal{C}\gamma_0\sigma$ or $d \in \mathcal{C}$, i.e. $d \in \mathcal{C} \cup \mathcal{C}\gamma_0\sigma$, and the property holds for $p + 1$.

($\mathcal{C} \cup \mathcal{C}\gamma_0\sigma \subset \langle \hat{\alpha}_n \rangle (b)$) We have $\mathcal{C} = \langle \gamma_0\gamma_1, \dots, \gamma_0\gamma_{n-1} \rangle (b)$. From Lemma 1 we deduce that the orbit $\langle \gamma_0\gamma_1, \dots, \gamma_0\gamma_{n-1} \rangle (b)$ in M is precisely

$$\langle \alpha_n\alpha_0\alpha_n\alpha_1, \dots, \alpha_n\alpha_0\alpha_n\alpha_{n-1} \rangle (b) \text{ in } AG(M)$$

and since $n \geq 2$ we have

$$\begin{aligned}
\langle \alpha_n\alpha_0\alpha_n\alpha_1, \dots, \alpha_n\alpha_0\alpha_n\alpha_{n-1} \rangle (b) &= \langle \alpha_0\alpha_n\alpha_n\alpha_1, \dots, \alpha_0\alpha_n\alpha_n\alpha_{n-1} \rangle (b) \\
&= \langle \alpha_0\alpha_1, \dots, \alpha_0\alpha_{n-1} \rangle (b)
\end{aligned}$$

We observe that $\langle \alpha_0\alpha_1, \dots, \alpha_0\alpha_{n-1} \rangle (b) \subset \langle \hat{\alpha}_n \rangle (b)$, hence $\mathcal{C} \subset \langle \hat{\alpha}_n \rangle (b)$. On the other hand, for all dart $d \in \mathcal{C}$, $d\gamma_0\sigma = d\alpha_n\alpha_0\alpha_n$. Since $n \geq 2$ we obtain $d\gamma_0\sigma = d\alpha_0\alpha_n\alpha_n = d\alpha_0$. From $\mathcal{C} \subset \langle \hat{\alpha}_n \rangle (b)$ and $d \in \mathcal{C}$ we deduce that $d \in \langle \hat{\alpha}_n \rangle (b)$, thus $d\alpha_0 \in \langle \hat{\alpha}_n \rangle (b)$. Eventually, $d\gamma_0\sigma \in \langle \hat{\alpha}_n \rangle (b)$ so that $\mathcal{C}\gamma_0\sigma \subset \langle \hat{\alpha}_n \rangle (b)$.

We conclude that $\hat{\alpha}_n b = \mathcal{C} \cup \mathcal{C}\gamma_0\sigma$. \square

Definition 17 (Associated cell) *The cell $\tilde{\mathcal{C}}$ as defined in Proposition 7 will be called the associated cell of \mathcal{C} in $AG(M)$.*

Now, we will prove that if a cell of a map M has a local degree of 2, then its associated cell in $AG(M)$ also has a local degree of 2. This result will be stated by Proposition 8.

Lemma 5 *Let $M = (\mathcal{D}, \gamma_0, \dots, \gamma_{n-1})$ be an n -map and $AG(M) = (\tilde{\mathcal{D}} = \mathcal{D} \cup \mathcal{D}', \alpha_0, \dots, \alpha_n)$ be the associated n - G -map of M . Let \mathcal{C} be an $(n-1)$ -cell with local degree 2 in M and C_1, C_2 be the two sets of darts defined by $\{C_1, C_2\} = \{ \langle \gamma_0 \gamma_1, \dots, \gamma_0 \gamma_{n-2} \rangle (b) \mid b \in \mathcal{C} \}$ (according to Definition 15), then we have*

$$(C_1 \cup C_1 \gamma_0 \alpha_n) \cap (C_2 \cup C_2 \gamma_0 \alpha_n) = \emptyset$$

Proof: We first rewrite

$$\begin{aligned} (C_1 \cup C_1 \gamma_0 \alpha_n) \cap (C_2 \cup C_2 \gamma_0 \alpha_n) &= ((C_1 \cup C_1 \gamma_0 \alpha_n) \cap C_2) \cup ((C_1 \cup C_1 \gamma_0 \alpha_n) \cap C_2 \gamma_0 \alpha_n) \\ &= ((C_1 \cap C_2) \cup (C_1 \gamma_0 \alpha_n \cap C_2)) \cup ((C_1 \cap C_2 \gamma_0 \alpha_n) \cup (C_1 \gamma_0 \alpha_n \cap C_2 \gamma_0 \alpha_n)) \end{aligned}$$

From $C_1 \cap C_2 = \emptyset$ and the fact that $\gamma_0 \alpha_n$ is a one-to-one map from \mathcal{D} to \mathcal{D}' we deduce that $C_1 \gamma_0 \alpha_n \cap C_2 \gamma_0 \alpha_n = \emptyset$. Since $\mathcal{D} \cap \mathcal{D}' = \emptyset$ and $\gamma_0 \alpha_n$ is a map from \mathcal{D} to \mathcal{D}' we also have $C_1 \cap C_1 \gamma_0 \alpha_n = \emptyset$, $C_1 \cap C_2 \gamma_0 \alpha_n = \emptyset$, $C_2 \cap C_2 \gamma_0 \alpha_n = \emptyset$, and $C_1 \cap C_2 \gamma_0 \alpha_n = \emptyset$. Thus, all the intersections of the above union of sets are empty. \square

Lemma 6 *If \mathcal{C} is an $(n-1)$ -cell with local degree 2 in an n -map M , then the associated cell of \mathcal{C} in $AG(M)$ has local degree 2.*

Proof: Let $M = (\mathcal{D}, \gamma_0, \dots, \gamma_{n-1})$, $AG(M) = (\tilde{\mathcal{D}} = \mathcal{D} \cup \mathcal{D}', \alpha_0, \dots, \alpha_n)$ following Definition 7.

If \mathcal{C} has local degree 2 in M we have:

$$\{ \langle \gamma_0 \gamma_1, \dots, \gamma_0 \gamma_{n-2} \rangle (b) \mid b \in \mathcal{C} \} = \{C_1, C_2\}$$

where C_1 and C_2 are non-empty and disjoint sets. Thus, there exist $b_1, b_2 \in \mathcal{C}$ such that

- $C_1 = \langle \gamma_0 \gamma_1, \dots, \gamma_0 \gamma_{n-2} \rangle (b_1)$,
- $C_2 = \langle \gamma_0 \gamma_1, \dots, \gamma_0 \gamma_{n-2} \rangle (b_2)$,
- $\forall d \in \mathcal{C}, \langle \gamma_0 \gamma_1, \dots, \gamma_0 \gamma_{n-2} \rangle (d) \in \{C_1, C_2\}$.

Now, with $\tilde{\mathcal{C}} = \mathcal{C} \cup \mathcal{C} \gamma_0 \sigma$, we prove that

$$\{ \langle \alpha_{n-1}, \hat{\alpha}_n \rangle (d) \mid d \in \tilde{\mathcal{C}} \} = \{C_1 \cup C_1 \gamma_0 \sigma, C_2 \cup C_2 \gamma_0 \sigma\}$$

Let $d \in \tilde{\mathcal{C}}$. We may suppose wlog that $d \in C_1$ if $d \in \mathcal{C}$ and that $d \sigma \gamma_0 \in C_1$ if $d \in \mathcal{C} \gamma_0 \sigma$. In all cases, we prove that $\langle \alpha_{n-1}, \hat{\alpha}_n \rangle (d) = C_1 \cup C_1 \gamma_0 \sigma$.

Thus, let $d \in \mathcal{C} \cup \mathcal{C}\gamma_0\sigma$, we consider the set $\langle \alpha_{n-1}, \hat{\alpha}_n \rangle(d)$. If d' is a dart of the latter orbit, we have

$$d' = d\alpha_{k_1} \dots \alpha_{k_p}, p \in \mathbb{N}$$

where $k_j \in \{0, \dots, n-2\}$, $1 \leq j \leq p$.

We prove by recurrence on p , the length of the sequence $\alpha_{k_1} \dots \alpha_{k_p}$, that $d' \in C_1 \cup C_1\gamma_0\sigma$ with

$$C_1 = \langle \gamma_0\gamma_1, \dots, \gamma_0\gamma_{n-2} \rangle(d) \quad (2)$$

The case $p = 0$ comes from the assumption we made on d or $d\sigma\gamma_0$. Therefore, we suppose that the property holds for some $p \in \mathbb{N}$.

We have $d' = d\alpha_{k_1} \dots \alpha_{k_p} \alpha_{k_{p+1}}$ with $k_j \in \{0, \dots, n-2\}$, $1 \leq j \leq p+1$. Let us denote $b = d\alpha_{k_1} \dots \alpha_{k_p}$. From the recurrence hypothesis we know that $b \in C_1 \cup C_1\gamma_0\sigma$.

If $b \in C_1$, from Definition 7 and the fact that $k_{p+1} \leq n-2$ we have

$$d' = b\alpha_{k_{p+1}} = d\gamma_{k_{p+1}}\sigma$$

We may rewrite

$$d' = \begin{cases} b\gamma_0\sigma & \text{if } k_{p+1} = 0 \\ b\gamma_{k_{p+1}}\sigma(\sigma^{-1}\gamma_0\gamma_0\sigma) = d(\gamma_{k_{p+1}}\gamma_0)\gamma_0\sigma & \text{if } 0 < k_{p+1} < n-1 \end{cases}$$

In the second case, $\gamma_{k_{p+1}}$ is an involution since $k_{p+1} < n-1$ therefore $d(\gamma_{k_{p+1}}\gamma_0) = d(\gamma_0\gamma_{k_{p+1}})^{-1}$. Thus, in both cases $b \in C_1$ implies that $d' \in C_1\gamma_0\sigma$ (see 2).

If $b \in C_1\gamma_0\sigma$, then $b = b'\gamma_0\sigma$ for some dart $b' \in C_1$. Then again from Definition 7 we have $d' = b\sigma^{-1}\gamma_{k_{p+1}} = b''\gamma_0\sigma\sigma^{-1}\gamma_{k_{p+1}} = b''\gamma_0\gamma_{k_{p+1}}$. If $k_{p+1} = 0$ we obtain that $d' = b''\gamma_0\gamma_0 = b'' \in C_1$, otherwise $d' = b''\gamma_0\gamma_{k_{p+1}} \in C_1$ by (2).

We conclude that $b\alpha_{k_{p+1}} \in C_1 \cup C_1\gamma_0\sigma$, so that the property holds for $p+1$, hence for all $p \in \mathbb{N}$. Eventually, $\langle \alpha_{n-1}, \hat{\alpha}_n \rangle(d) \subset C_1 \cup C_1\gamma_0\sigma$.

Now, from the definition of C_1 (2) it is straightforward that $C_1 \subset \langle \alpha_0, \dots, \alpha_{n-2} \rangle(d)$. On the other hand, we have $C_1\gamma_0\sigma = C_1\alpha_n\alpha_0\alpha_n$. Since $n \geq 2$ we obtain $C_1\gamma_0\sigma = C_1\alpha_0$. Therefore, $C_1 \subset \langle \alpha_0, \dots, \alpha_{n-2} \rangle(d)$ implies that $C_1\gamma_0\sigma \subset \langle \alpha_0, \dots, \alpha_{n-2} \rangle(d)$. Thus we have $C_1 \cup C_1\gamma_0\sigma \subset \langle \alpha_0, \dots, \alpha_{n-2} \rangle(d)$.

Finally, for all dart $d \in \tilde{\mathcal{C}}$, we have proved that $\langle \alpha_0, \dots, \alpha_{n-2} \rangle(d) = C_1 \cup C_1\gamma_0\sigma$ or $\langle \alpha_0, \dots, \alpha_{n-2} \rangle(d) = C_2 \cup C_2\gamma_0\sigma$. Since $C_1 \cup C_1\gamma_0\sigma$ and $C_2 \cup C_2\gamma_0\sigma$ are distinct sets (Lemma 5), we obtain that $\tilde{\mathcal{C}}$ has a local degree 2 according to Definition 12. \square

Lemma 7 Let $M = (\mathcal{D}, \gamma_0, \dots, \gamma_{n-1})$ be an n -map and $AG(M) = (\tilde{\mathcal{D}} = \mathcal{D} \cup \mathcal{D}', \alpha_0, \dots, \alpha_n)$ be the associated n - G -map of M . Let \mathcal{C} be an i -cell with local degree 2 in M for $0 \leq i < n - 1$ and C_1, C_2 be the two sets of darts defined by $\{C_1, C_2\} = \{ \langle \hat{\gamma}_i, \hat{\gamma}_{i+1} \rangle (b) \mid b \in \mathcal{C} \}$ (according to Definition 15), then we have

$$(C_1 \cup C_1 \gamma_0 \alpha_n) \cap (C_2 \cup C_2 \gamma_0 \alpha_n) = \emptyset$$

Proof: We first rewrite

$$\begin{aligned} (C_1 \cup C_1 \alpha_n) \cap (C_2 \cup C_2 \alpha_n) &= ((C_1 \cup C_1 \alpha_n) \cap C_2) \cup ((C_1 \cup C_1 \alpha_n) \cap C_2 \alpha_n) \\ &= ((C_1 \cap C_2) \cup (C_1 \alpha_n \cap C_2)) \cup ((C_1 \cap C_2 \alpha_n) \cup (C_1 \alpha_n \cap C_2 \alpha_n)) \end{aligned}$$

From $C_1 \cap C_2 = \emptyset$ and the fact that α_n is a one-to-one map from \mathcal{D} to \mathcal{D}' we deduce that $C_1 \alpha_n \cap C_2 \alpha_n = \emptyset$. Since $\mathcal{D} \cap \mathcal{D}' = \emptyset$ and α_n is a map from \mathcal{D} to \mathcal{D}' we also have $C_1 \cap C_1 \alpha_n = \emptyset$, $C_1 \cap C_2 \alpha_n = \emptyset$, $C_2 \cap C_2 \alpha_n = \emptyset$, and $C_1 \cap C_2 \alpha_n = \emptyset$. Thus, all the intersections of the above union of sets are empty. \square

Lemma 8 If \mathcal{C} is an i -cell with local degree 2 in an n -map M for $i < n - 1$, then the associated cell of \mathcal{C} in $AG(M)$ has local degree 2.

Proof: Let $M = (\mathcal{D}, \gamma_0, \dots, \gamma_{n-1})$ and $AG(M) = (\tilde{\mathcal{D}} = \mathcal{D} \cup \mathcal{D}', \alpha_0, \dots, \alpha_n)$ following Definition 7.

Since $i < n - 1$ and \mathcal{C} has local degree 2 in M we have:

$$\{ \langle \hat{\gamma}_i, \hat{\gamma}_{i+1} \rangle (b) \mid b \in \mathcal{C} \} = \{C_1, C_2\}$$

where C_1 and C_2 are non-empty disjoint sets. Thus, there exists $b_1, b_2 \in \mathcal{C}$ such that

- $C_1 = \langle \hat{\gamma}_i, \hat{\gamma}_{i+1} \rangle (b_1)$,
- $C_2 = \langle \hat{\gamma}_i, \hat{\gamma}_{i+1} \rangle (b_2)$,
- $\forall d \in \mathcal{D}, \langle \hat{\gamma}_i, \hat{\gamma}_{i+1} \rangle (d) \in \{C_1, C_2\}$.

With $\tilde{\mathcal{C}} = \mathcal{C} \cup \mathcal{C}\sigma$, we prove that

$$\{ \langle \hat{\alpha}_i, \hat{\alpha}_{i+1} \rangle (d) \mid d \in \tilde{\mathcal{C}} \} = \{C_1 \cup C_1 \sigma, C_2 \cup C_2 \sigma\}$$

Let $d \in \tilde{\mathcal{C}}$. We may suppose wlog that $d \in C_1$ if $d \in \mathcal{C}$ and that $d\sigma^{-1} \in C_1$ if $d \in \mathcal{C}\sigma$. In all cases, we prove that $\langle \hat{\alpha}_i, \hat{\alpha}_{i+1} \rangle (d) = C_1 \cup C_1 \sigma$.

Thus, let $d \in \tilde{\mathcal{C}}$, we consider the set $\langle \hat{\alpha}_i, \hat{\alpha}_{i+1} \rangle (d)$. Let d' be a dart of the latter orbit. We have:

$$d' = d\alpha_{k_1}\alpha_{k_2}\dots\alpha_{k_q}, \quad q \in \mathbb{N}$$

where $k_j \in \{0, \dots, n\} \setminus \{i, i+1\}$ for $j \in \{1, \dots, q\}$.

We prove by recurrence on p , the length of the sequence $\alpha_{k_1}\alpha_{k_2}\dots\alpha_{k_p}$, that $d' \in C_1 \cup C_1\sigma$ with $C_1 = \langle \hat{\gamma}_i, \hat{\gamma}_{i+1} \rangle (b_1)$. If $p = 0$, since we supposed that $d \in C_1$ or $d\sigma^{-1} \in C_1$ (i.e. $d \in C_1\sigma$) the property holds and there is nothing left to prove.

Now, we suppose that the property is verified for some $p \in \mathbb{N}$. Let $d' = d\alpha_{k_1}\alpha_{k_2}\dots\alpha_{k_p}\alpha_{k_{p+1}}$ with $d'' = d\alpha_{k_1}\alpha_{k_2}\dots\alpha_{k_p}$. From the recurrence hypothesis we have $d'' \in C_1 \cup C_1\sigma$. If $d'' \in C_1$, by Definition 7 we obtain that $d' = d''\gamma_{k_{p+1}}\sigma$ (if $k_{p+1} < n-1$), $d' = d''\gamma_{n-1}^{-1}\sigma$ (if $k_{p+1} = n-1$), or $d' = d''\sigma$ (if $k_{p+1} = n$); therefore in all cases $d' \in C_1\sigma$. If $d'' \in C_1\sigma$, we have $d' = d''\sigma^{-1}\gamma_{k_{p+1}}$ (if $k_{p+1} < n$) or $d' = d''\sigma^{-1}$ (if $k_{p+1} = n$); so that in both cases $d' \in C_1$. We conclude that $d' = d\alpha_{k_1} \in C_1 \cup C_1\sigma$ and the property holds for $p+1$, hence for any $p \in \mathbb{N}$.

Eventually, we obtained that

$$\langle \hat{\alpha}_i, \hat{\alpha}_{i+1} \rangle (d) \subset C_1 \cup C_1\sigma$$

Now, we show that $C_1 \cup C_1\sigma \subset \langle \hat{\alpha}_i, \hat{\alpha}_{i+1} \rangle (d)$. We have $C_1 = \langle \hat{\gamma}_i, \hat{\gamma}_{i+1} \rangle (b_1) = \langle \hat{\gamma}_i, \hat{\gamma}_{i+1} \rangle (d)$ and by Lemma 1:

$$\langle \hat{\gamma}_i, \hat{\gamma}_{i+1} \rangle (d) = \langle \alpha_n\alpha_0, \dots, \alpha_n\hat{\alpha}_i, \alpha_n\hat{\alpha}_{i+1}, \dots, \alpha_n\alpha_{n-1} \rangle (d)$$

Since $i < n-1$, we have $\alpha_n \in \{\alpha_0, \dots, \alpha_n\} \setminus \{\alpha_i, \alpha_{i+1}\}$, therefore

$$\langle \alpha_n\alpha_0, \dots, \alpha_n\hat{\alpha}_i, \alpha_n\hat{\alpha}_{i+1}, \dots, \alpha_n\alpha_{n-1} \rangle (d) \subset \langle \hat{\alpha}_i, \hat{\alpha}_{i+1} \rangle (d)$$

Finally, $C_1 \subset \langle \hat{\alpha}_i, \hat{\alpha}_{i+1} \rangle (d)$. Since $i+1 < n$, this also implies that $C_1\alpha_n = C_1\sigma \subset \langle \hat{\alpha}_i, \hat{\alpha}_{i+1} \rangle (d)$.

We conclude that $\langle \hat{\alpha}_i, \hat{\alpha}_{i+1} \rangle (d) = C_1 \cup C_1\sigma$.

The overall result is that for all $d \in \tilde{\mathcal{C}}$, either

- i) $\langle \hat{\alpha}_i, \hat{\alpha}_{i+1} \rangle (d) = C_1 \cup C_1\sigma$, or
- ii) $\langle \hat{\alpha}_i, \hat{\alpha}_{i+1} \rangle (d) = C_2 \cup C_2\sigma$.

where $C_1 \cup C_1\sigma$ and $C_2 \cup C_2\sigma$ are disjoint sets (by Lemma 7). In other words:

$$\left| \left\{ \langle \hat{\alpha}_i, \hat{\alpha}_{i+1} \rangle (d) \mid d \in \tilde{\mathcal{C}} \right\} \right| = 2$$

or again, $\tilde{\mathcal{C}}$ has a local degree 2 according to Definition 12. \square

Proposition 8 *If M is an n -map and \mathcal{C} is an i -cell with local degree 2 in M (Definition 15) for $0 \leq i \leq n-1$, then the associated cell of \mathcal{C} in $AG(M)$ has a local degree of 2 (Definition 12).*

Proof: The case $i = n-1$ is proved by Lemma 6, and the case $i < n-1$ by Lemma 8. \square

Lemma 9 *Let $G = (\mathcal{D}, \gamma_0, \dots, \gamma_{n-1})$ be an n - G -map and $AG(M) = (\tilde{\mathcal{D}} = \mathcal{D} \cup \mathcal{D}', \alpha_0, \dots, \alpha_n)$ be an associated n - G -map of M following Definition 7. For all $i \leq n-2$ and all $b \in \mathcal{D}$, we have*

$$\langle \hat{\alpha}_i, \hat{\alpha}_{i+1} \rangle(b) \subset \langle \hat{\gamma}_i, \hat{\gamma}_{i+1} \rangle(b) \cup \langle \hat{\gamma}_i, \hat{\gamma}_{i+1} \rangle(b) \alpha_n$$

Proof: Let $d \in \langle \hat{\alpha}_i, \hat{\alpha}_{i+1} \rangle(b)$, we may write

$$d = b \alpha_{k_1} \dots \alpha_{k_p}, \text{ for } p \in \mathbb{N}$$

with $k_h \in \{1, \dots, i-1\} \cup \{n\}$ for $1 \leq h \leq p$. We prove by recurrence on p , the length of the sequence of involutions $\alpha_{k_1} \dots \alpha_{k_p}$ that $d \in \langle \hat{\gamma}_i, \hat{\gamma}_{i+1} \rangle(b)$ or $d \in \langle \hat{\gamma}_i, \hat{\gamma}_{i+1} \rangle(b) \alpha_n$. The property obviously holds for $p = 0$. Thus, we may suppose that it is true for some $p \in \mathbb{N}$. Next, we consider a dart d such that $d = b \alpha_{k_1} \dots \alpha_{k_p} \alpha_{k_{p+1}}$. By the recurrence hypothesis, if we denote $b' = b \alpha_{k_1} \dots \alpha_{k_p}$, we know that either $b' \in \langle \hat{\gamma}_i, \hat{\gamma}_{i+1} \rangle(b)$ or $b' \in \langle \hat{\gamma}_i, \hat{\gamma}_{i+1} \rangle(b) \alpha_n$.

– Let us suppose that $b' \in \langle \hat{\gamma}_i, \hat{\gamma}_{i+1} \rangle(b)$. If $k_{p+1} = n$, then we have $d = b' \alpha_n$, hence $d \in \langle \hat{\gamma}_i, \hat{\gamma}_{i+1} \rangle(b) \alpha_n$. If $k_{p+1} \in \{0, \dots, n-1\}$, then $d = b' \alpha_{k_{p+1}}$, which we may write $d = b' \alpha_{k_{p+1}} \alpha_n \alpha_n = d' \gamma_{k_{p+1}}^{-1} \alpha_n$. Again, we have $d \in \langle \hat{\gamma}_i, \hat{\gamma}_{i+1} \rangle(b) \alpha_n$.

– Let us suppose that $b' \in \langle \hat{\gamma}_i, \hat{\gamma}_{i+1} \rangle(b) \alpha_n$. Then $b' = b'' \alpha_n$ for some dart $b'' \in \langle \hat{\gamma}_i, \hat{\gamma}_{i+1} \rangle(b)$. If $k_{p+1} = n$, then we have $d = b' \alpha_n = b'' \alpha_n \alpha_n = b''$, hence $d \in \langle \hat{\gamma}_i, \hat{\gamma}_{i+1} \rangle(b) \alpha_n$. If $k_{p+1} \in \{0, \dots, n-1\}$, then $d = b'' \alpha_n \alpha_{k_{p+1}} = b'' \gamma_{k_{p+1}}$, thus again $d \in \langle \hat{\gamma}_i, \hat{\gamma}_{i+1} \rangle(b)$.

The property is therefore true for a sequence with length $p+1$, thus true for any $p \in \mathbb{N}$. \square

Lemma 10 *Let $M = (\mathcal{D}, \gamma_0, \dots, \gamma_{n-1})$ be an n -map and $AG(M) = (\tilde{\mathcal{D}} = \mathcal{D} \cup \mathcal{D}', \alpha_0, \dots, \alpha_n)$ be an associated n - G -map of M following Definition 7. Let $\Psi = \{\gamma_{k_1}, \dots, \gamma_{k_p}\} \subset \{\gamma_0, \dots, \gamma_{n-1}\}$ for $p \leq n$, and $\Phi = \{\alpha_{k_1}, \dots, \alpha_{k_p}\}$. For all $b \in \mathcal{D}$ we have*

$$\langle \Phi \rangle(b) \subset \left(\langle \Psi \rangle(b) \cup \langle \Psi \rangle(b) \alpha_n \right)$$

Proof: Let $d \in \langle \Psi \rangle(b)$. We may write

$$d = b\alpha_{h_1} \dots \alpha_{h_q}, \quad q \in \mathbb{N}$$

where $h_j \in \{k_1, \dots, k_p\}$ for all $j \in \{1, \dots, q\}$.

We prove by recurrence on q , the length of the sequence of involutions $\alpha_{h_1} \dots \alpha_{h_q}$, that either $d \in \langle \Psi \rangle(b)$ or $d \in \langle \Psi \rangle(b)\alpha_n$. The property is immediately verified for $q = 0$. Thus we assume that the property is valid for some integer p and we consider the dart d with

$$d = b\alpha_{h_1} \dots \alpha_{h_q}\alpha_{h_{q+1}}, \quad q \in \mathbb{N} \text{ and } h_j \in \{k_1, \dots, k_p\} \text{ for } 1 \leq j \leq q + 1$$

By the recurrence hypothesis, we have $d = b'\alpha_{h_{q+1}}$ where $b' \in \langle \Psi \rangle(b) \cup \langle \Psi \rangle(b)\alpha_n$.

If $b' \in \langle \Psi \rangle(b)$ we write $d = b'\alpha_{h_{q+1}}\alpha_n\alpha_n = b'(\alpha_n\alpha_{h_{q+1}})^{-1}\alpha_n = b'(\gamma_{h_{q+1}})^{-1}\alpha_n$ and we obtain that $d \in \langle \Psi \rangle(b)\alpha_n$.

If $b' \in \langle \Psi \rangle(b)\alpha_n$, $b' = b''\alpha_n$ for some dart $b'' \in \langle \Psi \rangle(b)$ and we obtain that $d = b''\alpha_n\alpha_{h_{q+1}} = b''\gamma_{h_{q+1}} \in \langle \Psi \rangle(b)$.

Eventually, we have proved that $d \in \langle \Psi \rangle(b)$ or $d \in \langle \Psi \rangle(b)\alpha_n$ when the sequence of involutions has a length $p + 1$. The property is thus true for any sequence. \square

Later on, we use the fact that a regular cell in M is associated with a regular cell in $AG(M)$. This will be stated by Proposition 9, whose proof is based on the next Lemmas.

Lemma 11 *If \mathcal{C} is an i -cell, $0 \leq i \leq n - 2$, in a map that satisfies property a) of Definition 16, then $\tilde{\mathcal{C}}$ in $AG(M)$ satisfies property a) of Definition 14.*

Proof: Let $M = (\mathcal{D}, \gamma_0, \dots, \gamma_{n-1})$ and $G = AG(M) = (\tilde{\mathcal{D}} = \mathcal{D} \cup \mathcal{D}', \alpha_0, \dots, \alpha_n)$.

- If $i < n - 3$.

We may write $\mathcal{C} = \langle \hat{\gamma}_i \rangle(b)$ for some $b \in \mathcal{D}$. Following Definition 17 we have $\tilde{\mathcal{C}} = \mathcal{C} \cup \mathcal{C}\alpha_n$.

Let $d \in \tilde{\mathcal{C}}$.

– If $d \in \mathcal{D}$, by Definition 16 we know that either $d\gamma_{i+1}\gamma_{i+2} = d\gamma_{i+2}\gamma_{i+1}$ or $d\gamma_{i+1}\gamma_{i+2} \notin \langle \hat{\gamma}_i, \hat{\gamma}_{i+1} \rangle(d\gamma_{i+2}\gamma_{i+1})$. By Lemma 1 we may write $d\alpha_n\alpha_{i+1}\alpha_n\alpha_{i+2} = d\alpha_n\alpha_{i+2}\alpha_n\alpha_{i+1}$ or $d\alpha_n\alpha_{i+1}\alpha_n\alpha_{i+2} \notin \langle \hat{\gamma}_i, \hat{\gamma}_{i+1} \rangle(d\alpha_n\alpha_{i+2}\alpha_n\alpha_{i+1})$.

Since $i + 1 \leq n - 2$ and $AG(M)$ is an n -G-map, we have $b\alpha_n\alpha_{i+1} = b\alpha_{i+1}\alpha_n$ and $b\alpha_n\alpha_{i+2} = b\alpha_{i+2}\alpha_n$ for all $b \in \mathcal{D}$. Hence, either $d\alpha_{i+1}\alpha_{i+2} = d\alpha_{i+2}\alpha_{i+1}$ or $d\alpha_{i+1}\alpha_{i+2} \notin \langle \hat{\gamma}_i, \hat{\gamma}_{i+1} \rangle (d\alpha_{i+2}\alpha_{i+1})$.

Now, if $d\alpha_{i+1}\alpha_{i+2} \neq d\alpha_{i+2}\alpha_{i+1}$ we have $d\alpha_{i+1}\alpha_{i+2} \notin \langle \hat{\gamma}_i, \hat{\gamma}_{i+1} \rangle (d\alpha_{i+2}\alpha_{i+1})$. In this case, let us suppose that $d\alpha_{i+1}\alpha_{i+2} \in \langle \hat{\alpha}_i, \hat{\alpha}_{i+1} \rangle (d\alpha_{i+2}\alpha_{i+1})$. By Lemma 10, we know that

$$\langle \hat{\alpha}_i, \hat{\alpha}_{i+1} \rangle (d\alpha_{i+2}\alpha_{i+1}) \subset \langle \hat{\gamma}_i, \hat{\gamma}_{i+1} \rangle (d\alpha_{i+2}\alpha_{i+1}) \cup \langle \hat{\gamma}_i, \hat{\gamma}_{i+1} \rangle (d\alpha_{i+2}\alpha_{i+1})\alpha_n$$

Thus, either $d\alpha_{i+1}\alpha_{i+2} \in \langle \hat{\gamma}_i, \hat{\gamma}_{i+1} \rangle (d\alpha_{i+2}\alpha_{i+1})$ or $d\alpha_{i+1}\alpha_{i+2} \in \langle \hat{\gamma}_i, \hat{\gamma}_{i+1} \rangle (d\alpha_{i+2}\alpha_{i+1})\alpha_n$. Since $d\alpha_{i+1}\alpha_{i+2} = d\gamma_{i+1}\gamma_{i+2} \in \mathcal{D}$ and $\langle \hat{\gamma}_i, \hat{\gamma}_{i+1} \rangle (d\alpha_{i+2}\alpha_{i+1})\alpha_n \subset \mathcal{D}'$ we necessarily have $d\alpha_{i+1}\alpha_{i+2} \in \langle \hat{\gamma}_i, \hat{\gamma}_{i+1} \rangle (d\alpha_{i+2}\alpha_{i+1})$, a contradiction. Therefore, $d\alpha_{i+1}\alpha_{i+2} \notin \langle \hat{\alpha}_i, \hat{\alpha}_{i+1} \rangle (d\alpha_{i+2}\alpha_{i+1})$.

Eventually, we have proved that either $d\alpha_{i+1}\alpha_{i+2} = d\alpha_{i+2}\alpha_{i+1}$ or $d\alpha_{i+1}\alpha_{i+2} \notin \langle \hat{\alpha}_i, \hat{\alpha}_{i+1} \rangle (d\alpha_{i+2}\alpha_{i+1})$ which is property *a*) of Definition 14.

– If $d \in \mathcal{D}'$, then $d = d'\alpha_n$ for some dart $d' \in \mathcal{C}$ (Definition 17). From Definition 16 we know that either $d\alpha_n\gamma_{i+1}\gamma_{i+2} = d\alpha_n\gamma_{i+2}\gamma_{i+1}$ or $d\alpha_n\gamma_{i+1}\gamma_{i+2} \notin \langle \hat{\gamma}_i, \hat{\gamma}_{i+1} \rangle (d\alpha_n\gamma_{i+2}\gamma_{i+1})$.

If $d\alpha_n\gamma_{i+1}\gamma_{i+2} = d\alpha_n\gamma_{i+2}\gamma_{i+1}$, we have:

$$\begin{aligned} d\alpha_n\alpha_n\alpha_{i+1}\alpha_n\alpha_{i+2} &= d\alpha_n\alpha_n\alpha_{i+2}\alpha_n\alpha_{i+1} \quad (\text{Lemma 1}) \\ d\alpha_{i+1}\alpha_n\alpha_{i+2} &= d\alpha_{i+2}\alpha_n\alpha_{i+1} \\ d\alpha_{i+1}\alpha_{i+2}\alpha_n &= d\alpha_{i+2}\alpha_{i+1}\alpha_n \quad (i < n - 3) \\ d\alpha_{i+1}\alpha_{i+2} &= d\alpha_{i+2}\alpha_{i+1} \end{aligned}$$

If $d\alpha_n\gamma_{i+1}\gamma_{i+2} \neq d\alpha_n\gamma_{i+2}\gamma_{i+1}$, then $d\alpha_n\gamma_{i+1}\gamma_{i+2} \notin \langle \hat{\gamma}_i, \hat{\gamma}_{i+1} \rangle (d\alpha_n\gamma_{i+2}\gamma_{i+1})$. Since $d\alpha_n \in \mathcal{D}$, we have proved that $d\alpha_n\alpha_{i+1}\alpha_{i+2} \notin \langle \hat{\alpha}_i, \hat{\alpha}_{i+1} \rangle (d\alpha_n\alpha_{i+2}\alpha_{i+1})$. Since $i < n - 3$, $d\alpha_n\alpha_{i+2}\alpha_{i+1} = d\alpha_{i+2}\alpha_{i+1}\alpha_n$ $d\alpha_n\alpha_{i+1}\alpha_{i+2} = d\alpha_{i+1}\alpha_{i+2}\alpha_n$. Furthermore, since $n \notin \{i, i + 1\}$, $\langle \hat{\alpha}_i, \hat{\alpha}_{i+1} \rangle (d\alpha_{i+2}\alpha_{i+1}\alpha_n) = \langle \hat{\alpha}_i, \hat{\alpha}_{i+1} \rangle (d\alpha_{i+2}\alpha_{i+1})$. It follows that $d\alpha_{i+1}\alpha_{i+2}\alpha_n \notin \langle \hat{\alpha}_i, \hat{\alpha}_{i+1} \rangle (d\alpha_{i+2}\alpha_{i+1})$, which in turn implies that $d\alpha_{i+1}\alpha_{i+2} \notin \langle \hat{\alpha}_i, \hat{\alpha}_{i+1} \rangle (d\alpha_{i+2}\alpha_{i+1})$. Eventually, either $d\alpha_{i+1}\alpha_{i+2} = d\alpha_{i+2}\alpha_{i+1}$ or $d\alpha_{i+1}\alpha_{i+2} \notin \langle \hat{\alpha}_i, \hat{\alpha}_{i+1} \rangle (d\alpha_{i+2}\alpha_{i+1})$, which is property *a*) of Definition 14.

• If $i = n - 3$.

– If $d \in \mathcal{D}$. Following Definition 16, either $d\gamma_{n-2}\gamma_{n-1} = d\gamma_{n-1}^{-1}\gamma_{n-2}$, or $[\dots]$.

If $d\gamma_{n-2}\gamma_{n-1} = d\gamma_{n-1}^{-1}\gamma_{n-2}$, by Lemma 1 we deduce that $d\alpha_n\alpha_{n-2}\alpha_n\alpha_{n-1} = d\alpha_{n-1}\alpha_n\alpha_n\alpha_{n-2}$. Since $d\alpha_n\alpha_{n-2} = d\alpha_{n-2}\alpha_n$, we obtain that $d\alpha_{n-2}\alpha_{n-1} =$

$d\alpha_{n-1}\alpha_{n-2}$.

Now, if $d\gamma_{n-2}\gamma_{n-1} \neq d\gamma_{n-1}^{-1}\gamma_{n-1}$, it follows (Definition 16) that

$$d\gamma_{n-2} \notin \left(\langle \hat{\gamma}_{n-3}, \hat{\gamma}_{n-2} \rangle (d\gamma_{n-1}^{-1}\gamma_{n-2})\gamma_{n-1}^{-1} \cup \langle \hat{\gamma}_{n-3}, \hat{\gamma}_{n-2} \rangle (d\gamma_{n-1}\gamma_{n-2})\gamma_{n-1} \right) \quad (3)$$

Suppose that $d\alpha_{n-2}\alpha_{n-1} \in \langle \hat{\alpha}_{n-3}, \hat{\alpha}_{n-2} \rangle (d\alpha_{n-1}\alpha_{n-2})$, which we may rewrite $d\alpha_{n-2}\alpha_n\alpha_n\alpha_{n-1} \in \langle \hat{\alpha}_{n-3}, \hat{\alpha}_{n-2} \rangle (d\alpha_{n-1}\alpha_n\alpha_n\alpha_{n-2})$, or $d\alpha_n\alpha_{n-2}\alpha_n\alpha_{n-1} \in \langle \hat{\alpha}_{n-3}, \hat{\alpha}_{n-2} \rangle (d\alpha_{n-1}\alpha_n\alpha_n\alpha_{n-2})$. Since $d \in \mathcal{D}$ we obtain that $d\gamma_{n-2}\gamma_{n-1} \in \langle \hat{\alpha}_{n-3}, \hat{\alpha}_{n-2} \rangle (d\gamma_{n-1}^{-1}\gamma_{n-2})$.

By Lemma 10, we deduce that $d\gamma_{n-2}\gamma_{n-1} \in \langle \hat{\gamma}_{n-3}, \hat{\gamma}_{n-2} \rangle (d\gamma_{n-1}^{-1}\gamma_{n-2}) \cup \langle \hat{\gamma}_{n-3}, \hat{\gamma}_{n-2} \rangle (d\gamma_{n-1}^{-1}\gamma_{n-2})\alpha_n$. Finally, the fact that $d\gamma_{n-2}\gamma_{n-1} \in \mathcal{D}$ and $\langle \hat{\gamma}_{n-3}, \hat{\gamma}_{n-2} \rangle (d\gamma_{n-1}^{-1}\gamma_{n-2})\alpha_n \subset \mathcal{D}'$ implies that $d\gamma_{n-2}\gamma_{n-1} \in \langle \hat{\gamma}_{n-3}, \hat{\gamma}_{n-2} \rangle (d\gamma_{n-1}^{-1}\gamma_{n-2})$, i.e. $d\gamma_{n-2} \in \langle \hat{\gamma}_{n-3}, \hat{\gamma}_{n-2} \rangle (d\gamma_{n-1}^{-1}\gamma_{n-2})\gamma_{n-1}^{-1}$; which is a contradiction with (3). Therefore, $d\alpha_{n-2}\alpha_{n-1} \notin \langle \hat{\alpha}_{n-3}, \hat{\alpha}_{n-2} \rangle (d\alpha_{n-1}\alpha_{n-2})$.

– If $d \in \mathcal{D}'$, we have $d = b\alpha_n$ for some $b \in \mathcal{C}$. If \mathcal{C} is regular, since $d\alpha_n = b \in \mathcal{C}$, following Definition 16 either $d\alpha_n\gamma_{n-2}\gamma_{n-1}^{-1} = d\alpha_n\gamma_{n-1}\gamma_{n-2}$, or $[\dots]$.

If $d\alpha_n\gamma_{n-2}\gamma_{n-1}^{-1} = d\alpha_n\gamma_{n-1}\gamma_{n-2}$, by Lemma 1 we deduce that $d\alpha_n\alpha_n\alpha_{n-2}\alpha_{n-1}\alpha_n = d\alpha_n\alpha_n\alpha_{n-1}\alpha_n\alpha_{n-2}$. Since $d\alpha_n\alpha_{n-2} = d\alpha_{n-2}\alpha_n$, we obtain that $d\alpha_{n-2}\alpha_{n-1}\alpha_n = d\alpha_{n-1}\alpha_{n-2}\alpha_n$, hence $d\alpha_{n-2}\alpha_{n-1} = d\alpha_{n-1}\alpha_{n-2}$.

Now, if $d\alpha_n\gamma_{n-2}\gamma_{n-1}^{-1} \neq d\alpha_n\gamma_{n-1}\gamma_{n-2}$, it follows (Definition 16) that

$$d\alpha_n\gamma_{n-2} \notin \langle \hat{\gamma}_{n-3}, \hat{\gamma}_{n-2} \rangle (d\alpha_n\gamma_{n-1}\gamma_{n-2})\gamma_{n-1} \quad (4)$$

Let us suppose that $d\alpha_{n-2}\alpha_{n-1} \in \langle \hat{\alpha}_{n-3}, \hat{\alpha}_{n-2} \rangle (d\alpha_{n-1}\alpha_{n-2})$. Since $n \notin \{n-2, n-3\}$ we have $\langle \hat{\alpha}_{n-3}, \hat{\alpha}_{n-2} \rangle (d\alpha_{n-1}\alpha_{n-2}) = \langle \hat{\alpha}_{n-3}, \hat{\alpha}_{n-2} \rangle (d\alpha_{n-1}\alpha_{n-2}\alpha_n)$.

It follows that

$$d\alpha_n\alpha_n\alpha_{n-2}\alpha_{n-1}\alpha_n \in \langle \hat{\alpha}_{n-3}, \hat{\alpha}_{n-2} \rangle (d\alpha_n\alpha_n\alpha_{n-1}\alpha_{n-2}\alpha_n)$$

Since $d\alpha_n \in \mathcal{D}$, by Lemma 1 and from the fact that $b\alpha_n\alpha_{n-2} = b\alpha_{n-2}\alpha_n$ for all $b \in \tilde{\mathcal{D}}$, we obtain

$$d\alpha_n\gamma_{n-2}\gamma_{n-1}^{-1} \in \langle \hat{\alpha}_{n-3}, \hat{\alpha}_{n-2} \rangle (d\alpha_n\gamma_{n-1}\gamma_{n-2})$$

By Lemma 10 and the fact that $d\alpha_n\gamma_{n-2}\gamma_{n-1}^{-1} \in \mathcal{D}$ we deduce that

$$d\alpha_n\gamma_{n-2}\gamma_{n-1}^{-1} \in \langle \hat{\gamma}_{n-3}, \hat{\gamma}_{n-2} \rangle (d\alpha_n\gamma_{n-1}\gamma_{n-2})$$

in other words,

$$d\alpha_n\gamma_{n-2} \in \langle \hat{\gamma}_{n-3}, \hat{\gamma}_{n-2} \rangle (d\alpha_n\gamma_{n-1}\gamma_{n-2})\gamma_{n-1}$$

which is a contradiction with (4). Therefore, $d\alpha_{n-2}\alpha_{n-1} \notin \langle \hat{\alpha}_{n-3}, \hat{\alpha}_{n-2} \rangle (d\alpha_{n-1}\alpha_{n-2})$.

Eventually, we have proved that condition a) of Definition 14 is satisfied for all $d \in \tilde{\mathcal{C}}$.

• If $i = n - 2$.

– If $d \in \mathcal{D}$. Following Definition 16, we know that either $d\gamma_{n-1}^{-1} = d\gamma_{n-1}$ or $d\gamma_{n-1}^{-1} \notin \langle \gamma_1, \dots, \gamma_{n-3} \rangle (d\gamma_{n-1})$.

If $d\gamma_{n-1}^{-1} = d\gamma_{n-1}$, by Lemma 1 we have $d\alpha_{n-1}\alpha_n = d\alpha_n\alpha_{n-1}$.

Now, let us consider the case when $d\gamma_{n-1}^{-1} \neq d\gamma_{n-1}$. Necessarily, we have $d\gamma_{n-1}^{-1} \notin \langle \gamma_1, \dots, \gamma_{n-3} \rangle (d\gamma_{n-1})$.

Suppose that $d\alpha_{n-1}\alpha_n \in \langle \hat{\alpha}_{n-2}, \hat{\alpha}_{n-1} \rangle (d\alpha_n\alpha_{n-1})$. Since $d \in \mathcal{D}$, we can write $d\gamma_{n-1}^{-1} \in \langle \hat{\alpha}_{n-2}, \hat{\alpha}_{n-1} \rangle (d\gamma_{n-1})$, and using Lemma 10 we obtain that $d\gamma_{n-1}^{-1} \in \langle \hat{\gamma}_{n-2}, \hat{\gamma}_{n-1} \rangle (d\gamma_{n-1}) \cup \langle \hat{\gamma}_{n-2}, \hat{\gamma}_{n-1} \rangle (d\gamma_{n-1})\alpha_n$. Since $d\gamma_{n-1}^{-1} \in \mathcal{D}$ and $\langle \hat{\gamma}_{n-2}, \hat{\gamma}_{n-1} \rangle (d\gamma_{n-1})\alpha_n \subset \mathcal{D}'$ it follows that $d\gamma_{n-1}^{-1} \in \langle \hat{\gamma}_{n-2}, \hat{\gamma}_{n-1} \rangle (d\gamma_{n-1})$, a contradiction. Finally, we obtain that $d\alpha_{n-1}\alpha_n \notin \langle \hat{\alpha}_{n-2}, \hat{\alpha}_{n-1} \rangle (d\alpha_n\alpha_{n-1})$.

We conclude that either $d\alpha_{n-1}\alpha_n = d\alpha_n\alpha_{n-1}$ or $d\alpha_{n-1}\alpha_n \notin \langle \hat{\alpha}_{n-2}, \hat{\alpha}_{n-1} \rangle (d\alpha_n\alpha_{n-1})$, which is property a) of Definition 14.

– If $d \in \mathcal{D}'$, we have $d = d'\alpha_n$ for some dart $d' \in \mathcal{D}$.

Following Definition 16, we know that either $d'\gamma_{n-1}^{-1} = d'\gamma_{n-1}$ or $d'\gamma_{n-1}^{-1} \notin \langle \gamma_1, \dots, \gamma_{n-3} \rangle (d'\gamma_{n-1}^{-1})$.

If $d'\gamma_{n-1}^{-1} = d'\gamma_{n-1}$ we obtain that $d\alpha_n\alpha_{n-1}\alpha_n = d\alpha_n\alpha_n\alpha_{n-1}$, thus $d\alpha_n\alpha_{n-1}\alpha_n = d\alpha_{n-1}$ or again $d\alpha_n\alpha_{n-1} = d\alpha_{n-1}\alpha_n$.

If $d'\gamma_{n-1}^{-1} \neq d'\gamma_{n-1}$ we have necessarily $d'\gamma_{n-1}^{-1} \notin \langle \gamma_1, \dots, \gamma_{n-3} \rangle (d'\gamma_{n-1}^{-1})$.

Let us suppose that $d\alpha_{n-1}\alpha_n \in \langle \hat{\alpha}_{n-2}, \hat{\alpha}_{n-1} \rangle (d\alpha_n\alpha_{n-1})$. Since $n \notin \{n - 2, n - 1\}$ we deduce that $d\alpha_{n-1} \in \langle \hat{\alpha}_{n-2}, \hat{\alpha}_{n-1} \rangle (d\alpha_n\alpha_{n-1})$ and then also that $d\alpha_{n-1} \in \langle \hat{\alpha}_{n-2}, \hat{\alpha}_{n-1} \rangle (d\alpha_n\alpha_{n-1}\alpha_n)$. Substituting with $d = d'\alpha_n$ we obtain $d'\alpha_n\alpha_{n-1} \in \langle \hat{\alpha}_{n-2}, \hat{\alpha}_{n-1} \rangle (d'\alpha_n\alpha_n\alpha_{n-1}\alpha_n)$, eventually $d'\gamma_{n-1} \in \langle \hat{\alpha}_{n-2}, \hat{\alpha}_{n-1} \rangle (d'\gamma_{n-1}^{-1})$, a contradiction. Eventually, $d\alpha_{n-1}\alpha_n \notin \langle \hat{\alpha}_{n-2}, \hat{\alpha}_{n-1} \rangle (d\alpha_n\alpha_{n-1})$.

We obtain that property a) of Definition 14 is satisfied by $\tilde{\mathcal{C}}$. \square

Lemma 12 *If \mathcal{C} is an i -cell in an n -map for $i \leq n - 2$ and such that it satisfies property b) of Definition 16, then $\tilde{\mathcal{C}}$ in $AG(M)$ satisfies property b) of Definition 14.*

Proof: Let us denote $M = (\mathcal{D}, \gamma_0, \dots, \gamma_{n-1})$ and $G = AG(M) = (\tilde{\mathcal{D}} = \mathcal{D} \cup \mathcal{D}', \alpha_0, \dots, \alpha_n)$. Furthermore, let \mathcal{C} be an i -cell of M that satisfies property b), and let d be a dart of $\tilde{\mathcal{C}}$.

• If $i < n - 2$.

– If $d \in \mathcal{D}$. Suppose that $d\alpha_{i+1} \in \langle \hat{\gamma}_i, \hat{\gamma}_{i+1} \rangle (d)$. By Lemma 10, $\langle \hat{\alpha}_i, \hat{\alpha}_{i+1} \rangle (d) \subset \langle \hat{\gamma}_i, \hat{\gamma}_{i+1} \rangle (d) \cup \langle \hat{\gamma}_i, \hat{\gamma}_{i+1} \rangle (d)\alpha_n$ so that either $d\alpha_{i+1} \in \langle \hat{\gamma}_i, \hat{\gamma}_{i+1} \rangle (d)$ or $d\alpha_{i+1} \in \langle \hat{\gamma}_i, \hat{\gamma}_{i+1} \rangle (d)\alpha_n$. Necessarily, we have $d\alpha_{i+1} \in \langle \hat{\gamma}_i, \hat{\gamma}_{i+1} \rangle (d)\alpha_n$ since $d\alpha_{i+1} \in \mathcal{D}'$. We deduce that $d\alpha_{i+1}\alpha_n \in \langle \hat{\gamma}_i, \hat{\gamma}_{i+1} \rangle (d)$, i.e. $d\alpha_n\alpha_{i+1} \in \langle \hat{\gamma}_i, \hat{\gamma}_{i+1} \rangle (d)$, since $i + 1 < n - 1$. Thus, we have $d\gamma_{i+1} \in \langle \hat{\gamma}_i, \hat{\gamma}_{i+1} \rangle (d)$. But this is a contradiction with the fact that \mathcal{C} is regular in M (point b) of Definition 16). Hence, $d\alpha_{i+1} \notin \langle \hat{\gamma}_i, \hat{\gamma}_{i+1} \rangle (d)$ which is property b) of Definition 14.

– If $d \in \mathcal{D}'$, we have $d = b\alpha_n$ for some dart $b \in \mathcal{C}$. Suppose that $d\alpha_{i+1} = b\alpha_n\alpha_{i+1} \in \langle \hat{\alpha}_i, \hat{\alpha}_{i+1} \rangle (b\alpha_n)$. Since $n \notin \{i, i + 1\}$ we have $b\alpha_n\alpha_{i+1} \in \langle \hat{\alpha}_i, \hat{\alpha}_{i+1} \rangle (b)$. By Lemma 10,

$$\langle \hat{\alpha}_i, \hat{\alpha}_{i+1} \rangle (b) \subset \langle \hat{\gamma}_i, \hat{\gamma}_{i+1} \rangle (b) \cup \langle \hat{\gamma}_i, \hat{\gamma}_{i+1} \rangle (b)\alpha_n$$

so either $b\alpha_n\alpha_{i+1} \in \langle \hat{\gamma}_i, \hat{\gamma}_{i+1} \rangle (b)$ or $b\alpha_n\alpha_{i+1} \in \langle \hat{\gamma}_i, \hat{\gamma}_{i+1} \rangle (b)\alpha_n$.

Since $b\alpha_n\alpha_{i+1} \in \mathcal{D}$, necessarily $b\alpha_n\alpha_{i+1} \in \langle \hat{\gamma}_i, \hat{\gamma}_{i+1} \rangle (b)$. In other words, $b\gamma_{i+1} \in \langle \hat{\gamma}_i, \hat{\gamma}_{i+1} \rangle (d)$, which is a contradiction with the fact that b belongs to a regular i -cell of M (property b) of Definition 16). Therefore, $d\alpha_{i+1} \notin \langle \hat{\alpha}_i, \hat{\alpha}_{i+1} \rangle (d)$ so that property b) of Definition 14 is verified.

• If $i = n - 2$.

– If $d \in \mathcal{D}$, following Definition 14 we have $b\gamma_{n-1} \notin \langle \gamma_0, \dots, \gamma_{n-3} \rangle (b)$.

Now, let us suppose that $d\alpha_{n-1} \in \langle \hat{\alpha}_{n-2}, \hat{\alpha}_{n-1} \rangle (d)$. Since $n \notin \{n - 2, n - 1\}$ we deduce that $d\alpha_{n-1}\alpha_n \in \langle \hat{\alpha}_{n-2}, \hat{\alpha}_{n-1} \rangle (d)$ and by Lemma 9 that $d\gamma_{n-1}^{-1} \in \langle \hat{\gamma}_{n-2}, \hat{\gamma}_{n-1} \rangle (d)$, which is a contradiction. Thus, $d\alpha_{n-1} \notin \langle \hat{\alpha}_{n-2}, \hat{\alpha}_{n-1} \rangle (d)$.

– If $d \in \mathcal{D}'$, we have $d = d'\alpha_n$ for some dart $d' \in \mathcal{D}$. Let us suppose that $d\alpha_{n-1} \in \langle \hat{\alpha}_{n-2}, \hat{\alpha}_{n-1} \rangle (d)$. Since $d' = d\alpha_n$ we obtain that $d'\alpha_n\alpha_{n-1} \in \langle \hat{\alpha}_{n-2}, \hat{\alpha}_{n-1} \rangle (d'\alpha_n)$. Again, since $n \notin \{n - 2, n - 1\}$ we have $d'\alpha_n\alpha_{n-1} \in \langle \hat{\alpha}_{n-2}, \hat{\alpha}_{n-1} \rangle (d')$, and by Lemma 9 (since $d' \in \mathcal{D}$) $d'\gamma_{n-1} \in \langle \hat{\gamma}_{n-2}, \hat{\gamma}_{n-1} \rangle (d')$. A contradiction with the fact that \mathcal{C} is regular (Definition 16). Thus, again $d\alpha_{n-1} \notin \langle \hat{\alpha}_{n-2}, \hat{\alpha}_{n-1} \rangle (d)$.

Eventually, condition b) of Definition 14 is satisfied by $\tilde{\mathcal{C}}$. \square

Proposition 9 *Let $M = (\mathcal{D}, \gamma_0, \dots, \gamma_{n-1})$ be an n -map and $AG(M) = (\tilde{\mathcal{D}} = \mathcal{D} \cup \mathcal{D}', \alpha_0, \dots, \alpha_n)$ be an associated n - G -map of M following Definition 7. If \mathcal{C} is a regular i -cell in M for $0 \leq i \leq n-2$ (Definition 16), then the associated cell of \mathcal{C} in $AG(M)$ is regular (Definition 14).*

Proof: If \mathcal{C} satisfies properties a) and b) of Definition 16 then by Lemma 11 $\tilde{\mathcal{C}}$ satisfies property a) Definition 14 and by Lemma 12 it satisfies property b) of Definition 14. Hence $\tilde{\mathcal{C}}$ is regular in G . \square

Proposition 10 *Let $G = (\mathcal{D}, \gamma_0, \dots, \gamma_{n-1})$ be an n -map and let us consider $d \in \mathcal{D}$. The i -cell $\mathcal{C}_i(d)$ is of local degree at most 2 if:*

- For $i \in \{0, \dots, n-3\}$, $b\gamma_{i+1}^{-1}\gamma_{i+2} = b\gamma_{i+2}^{-1}\gamma_{i+1}$ for all $b \in \mathcal{C}_i(d)$.
- For $i = n-2$, $b\gamma_{n-1}^{-1} = b\gamma_{n-1} \Leftrightarrow b = b\gamma_{n-1}^2$ for all $b \in \mathcal{C}_i(d)$.

Such a characterization may be equivalently performed in terms of the dual map $\bar{G} = (\mathcal{D}, \beta_n, \dots, \beta_1)$:

$$\forall i \in \{0, \dots, n-2\} \forall b \in \mathcal{C}_i(d), \quad b\beta_{i+1}^{-1}\beta_{i+2} = b\beta_{i+2}^{-1}\beta_{i+1}$$

Proof: Let us first show the equivalence between both characterizations:

- If $i \in \{0, \dots, n-3\}$

$$d\gamma_{i+1}^{-1}\gamma_{i+2} = d\beta_{i+1}^{-1}\beta_n^{-1}\beta_n\beta_{i+2} = d\beta_{i+1}^{-1}\beta_{i+2}$$

$$d\gamma_{i+2}^{-1}\gamma_{i+1} = d\beta_{i+2}^{-1}\beta_n^{-1}\beta_n\beta_{i+1} = d\beta_{i+2}^{-1}\beta_{i+1}$$

So that $d\gamma_{i+1}^{-1}\gamma_{i+2} = d\gamma_{i+2}^{-1}\gamma_{i+1}$ if and only if $d\beta_{i+1}^{-1}\beta_{i+2} = d\beta_{i+2}^{-1}\beta_{i+1}$.

- If $i = n-2$:

$$d\gamma_{n-1} = d\beta_n\beta_{n-1} \text{ and } d\gamma_{n-1}^{-1} = d\beta_{n-1}^{-1}\beta_n^{-1}$$

Since β_n is an involution we obtain:

$$d\gamma_{n-1} = d\beta_n^{-1}\beta_{n-1} \text{ and } d\gamma_{n-1}^{-1} = d\beta_{n-1}^{-1}\beta_n$$

So that $d\gamma_{n-1}^{-1} = d\gamma_{n-1}$ if and only if $d\beta_{n-1}^{-1}\beta_n = d\beta_n^{-1}\beta_{n-1}$.

Let us now show that the above equations characterize i -cells with local degree 2.

- If $i \in \{0, \dots, n-3\}$ let us consider a dart d such that:

$$d\gamma_{i+1}^{-1}\gamma_{i+2} = d\gamma_{i+2}^{-1}\gamma_{i+1}$$

Since $i \leq n-3$, γ_{i+1} is an involution and we have:

$$d\gamma_{i+1}^{-1}\gamma_{i+2} = d\gamma_{i+1}\gamma_{i+2} = d\gamma_{i+2}^{-1}\gamma_{i+1}$$

Since the above equation is valid for any dart $d \in \mathcal{C}_i(d)$, we may apply it to $(d\gamma_{i+2})$ and we obtain:

$$(d\gamma_{i+2})\gamma_{i+2}^{-1}\gamma_{i+1} = d\gamma_{i+2}\gamma_{i+1}\gamma_{i+2} = d\gamma_{i+1}$$

We have thus:

$$d\gamma_{i+2}\gamma_{i+1} = d\gamma_{i+2}\gamma_{i+1}\gamma_{i+2}\gamma_{i+2}^{-1} = d\gamma_{i+1}\gamma_{i+2}^{-1}$$

Let us now consider one dart $b \in \mathcal{C}_i(d) = \langle \gamma_0, \dots, \hat{\gamma}_i, \dots, \gamma_{n-1} \rangle (d)$. The dart b is equal to $d\varphi$ with $\varphi \in \langle \gamma_0, \dots, \hat{\gamma}_i, \dots, \gamma_{n-1} \rangle$. Let us consider φ as a word built on the alphabet $\{\gamma_0, \dots, \hat{\gamma}_i, \dots, \gamma_{n-1}\} \cup \{\gamma_0^{-1}, \dots, \hat{\gamma}_i^{-1}, \dots, \gamma_{n-1}^{-1}\}$. Within the general case, the symbol γ_{i+1} commutes with all the symbols of this alphabet except γ_{i+2} and γ_{i+2}^{-1} . But as we have shown, the relationship $d\gamma_{i+1}^{-1}\gamma_{i+2} = d\gamma_{i+2}^{-1}\gamma_{i+1}$ induces for all $d \in \mathcal{C}$:

$$\begin{cases} d\gamma_{i+2}\gamma_{i+1} = d\gamma_{i+1}\gamma_{i+2}^{-1} \\ d\gamma_{i+2}^{-1}\gamma_{i+1} = d\gamma_{i+1}\gamma_{i+2} \end{cases}$$

We may thus consider the natural p and the function

$$\psi \in \langle \gamma_0, \dots, \hat{\gamma}_i, \gamma_{i+1}, \dots, \gamma_{n-1} \rangle (d)$$

such that $b = d\gamma_{i+1}^p\psi$.

Since $i \leq n-3$, γ_{i+1} is an involution and:

– If p is even $d\gamma_{i+1}^p = d$ and:

$$b = d\psi \in \langle \gamma_0, \dots, \gamma_{i+1}, \dots, \gamma_{n-1} \rangle (d) = \mathcal{C}_{i+1}(d)$$

– If p is odd $d\gamma_{i+1}^p = d\gamma_{i+1}$ and:

$$b = d\gamma_{i+1}\psi \in \langle \gamma_0, \dots, \gamma_{i+1}, \dots, \gamma_{n-1} \rangle (d) = \mathcal{C}_{i+1}(d\gamma_{i+1})$$

Therefore any dart of $\mathcal{C}_i(d)$ belongs either to $\mathcal{C}_{i+1}(d)$ or to $\mathcal{C}_{i+1}(d\gamma_{i+1})$, $\mathcal{C}_i(d)$ is thus incident to at most two $i+1$ cells and its degree is at most 2.

- If $i = n-2$, $\mathcal{C}_{n-2}(d) = \langle \gamma_0, \dots, \gamma_{n-3}, \gamma_{n-1} \rangle (d)$. The permutation γ_{n-1} commutes with all γ_i , $i \leq n-3$ and we have thus as previously, for each $b \in \mathcal{C}_0(d)$ a function $\varphi \in \langle \gamma_0, \dots, \gamma_{n-3} \rangle$ such that $b = d\gamma_{n-1}^p\varphi$. We have thus $b \in \mathcal{C}_{n-1}(d)$ if p is even and $b \in \mathcal{C}_{n-1}(d\gamma_{n-1})$ if p is odd. The $n-2$ cell $\mathcal{C}_{n-2}(d)$ is thus incident to at most two $n-1$ cells: Its degree is at most 2.

□

Property 4 *An $(n-1)$ -cell in an n -map is of degree either 1 or 2. If the n -map is closed, then all $(n-1)$ -cells are of degree 2.*

3 Cells removal and contraction in G-maps and maps

3.1 Cells removal

Notation 3 If $S = \{E_i\}_{0 \leq i \leq N}$ is a set of sets for $N \in \mathbb{N}$, we denote by S^* the union of sets in S , i.e.

$$S^* = \bigcup_{0 \leq i \leq N} E_i$$

Definition 18 (Removal set) Let $G = (\mathcal{D}, \alpha_0, \dots, \alpha_n)$ be an n -G-map (resp. $M = (\mathcal{D}, \gamma_0, \dots, \gamma_{n-1})$ be an n -map) and $S_r = \{R_i\}_{0 \leq i \leq n}$ be sets of i -cells with $R_n = \emptyset$. The family of sets S_r is called a removal set in G (resp. in M). Furthermore, for such a family we will denote $R = \bigcup_{i=0}^n R_i$, the set of all cells of S_r , so that R^* is the set of all darts in S_r .

Definition 19 (Removal kernel) Let G be an n -G-map. A removal kernel $K_r = \{R_i\}_{0 \leq i \leq n}$ in G is a removal set such that all cells of R are disjoint (i.e. $\forall \mathcal{C}, \mathcal{C}' \in R, \mathcal{C} \cap \mathcal{C}' = \emptyset$) and all of them are regular cells with local degree 2 (Definitions 14 and 12). A removal kernel is defined the same way for an n -map M using Definitions 16 and 15 for the notions of regularity and local degree, respectively.

Lemma 13 Let $G = (\mathcal{D}, \alpha_0, \dots, \alpha_n)$ be an n -G-map and $K_r = \{R_i\}_{0 \leq i \leq n}$ be a removal kernel in G . We have $R_i^* \alpha_i \cap R^* \subset R_i^*$ for all $i, 0 \leq i \leq n$.

Corollary 3 Let $G = (\mathcal{D}, \alpha_0, \dots, \alpha_n)$ be an n -G-map and $K_r = \{R_i\}_{0 \leq i \leq n}$ be a removal kernel in G . With $\mathcal{D}' = \mathcal{D} \setminus R^*$ we have for all $i \in \{0, \dots, n\}$:

$$R_i^* \alpha_i \setminus R_i^* \subset \mathcal{D}' \text{ and } R_i^* \alpha_i \cap \mathcal{D}' = R_i^* \alpha_i \setminus R_i^* \quad (5)$$

Proof of Lemma 13: Let $d' = d\alpha_i$ for $d \in R_i^*$ (i.e., $d' \in R_i^* \alpha_i$) and such that $d' \in R^*$. We prove that $d' \in R_i^*$.

Since $d' \in R^*$, it is sufficient to prove that $d' \notin R_j^*$ for all $j \neq i$. Let us suppose that $d' \in R_j^*$ with $i \neq j$, which means that d' belongs to a j -cell $\mathcal{C}_j \in R_j$:

$$d' \in \langle \alpha_0, \dots, \hat{\alpha}_j, \dots, \alpha_n \rangle (d''), d'' \in R_j^*$$

Since $i \neq j$, $d' \alpha_i$ also belongs to the above j -cell. However, $d' \alpha_i = d \alpha_i \alpha_i = d \in R_i^*$. We have exhibited a dart which belongs to both a removed j -cell and a removed i -cell. This is a contradiction with the fact that cells of R do not intersect (Definition 19). \square

Proof of Corollary 3: From Lemma 13 $R_i^* \alpha_i \cap R^* \subset R_i^*$. Since $R_i^* \subset R^*$ we deduce that $R_i^* \alpha_i \setminus R^* = R_i^* \alpha_i \setminus R_i^*$. Now, because $R_i^* \alpha_i \setminus R^*$ is a subset of $\mathcal{D}' = \mathcal{D} \setminus R^*$ we obtain that $R_i^* \alpha_i \setminus R_i^* \subset \mathcal{D}'$.

On the other hand, let us write:

$$R_i^* \alpha_i \cap \mathcal{D}' = R_i^* \alpha_i \cap (\mathcal{D} \setminus R^*) = (R_i^* \alpha_i \cap \mathcal{D}) \setminus R^* = R_i^* \alpha_i \setminus R^*$$

As shown above, we have $R_i^* \alpha_i \setminus R^* = R_i^* \alpha_i \setminus R_i^*$. Finally, we obtain that $R_i^* \alpha_i \cap \mathcal{D}' = R_i^* \alpha_i \setminus R_i^*$. \square

The following definition for cells removal is adapted from [5] where a definition combining removals and contractions is given. The definition below is obtained by considering that no cell is to be contracted.

In her definition, Grasset required that cells of the removal kernel should have a local degree two according to her definition (Definition 13). We have seen that this definition is both too restrictive to be a valid definition for the local degree 2, but also that it does not exclude cells with local degree 1.

We know that excluding cells with local degree 1 from Grasset's definition yields the notion of *regular cells* with local degree 2 (Definition 14). Both notions being equivalent, as shown by Theorem 1. Therefore, the definition we present below, although not exactly the one given by Grasset, is just more restrictive in the sense that no cell with a local degree one should be in the removal kernel.

Definition 20 (Cells removal in n -G-maps [5]) *Let $G = (\mathcal{D}, \alpha_0, \dots, \alpha_n)$ be an n -G-map and $K_r = \{R_i\}_{0 \leq i \leq n-1}$ a removal kernel in G . Let $BV_i = R_i^* \alpha_i \setminus R_i^*$, $\forall i, 0 \leq i \leq n$. The set BV_i is called the set of surviving darts which are neighbors of an i -cell to be removed. The n -G-map resulting of the removal of the cells of R is $G' = (\mathcal{D}', \alpha'_0, \dots, \alpha'_n)$ defined by:*

- (1) $\mathcal{D}' = \mathcal{D} \setminus R^*$;
- (2) $\forall i, 0 \leq i \leq n, \forall b \in \mathcal{D}' \setminus BV_i, b\alpha'_i = b\alpha_i$;
- (3) $\forall i, 0 \leq i < n, \forall b \in BV_i, b\alpha'_i = b' = b(\alpha_i \alpha_{i+1})^k \alpha_i$ where k is the smallest integer such that $b' \in BV_i$.

The following definition provides us with an equivalent definition of the removal of cells.

Definition 21 (Cells removal in n -G-maps) *Let $G = (\mathcal{D}, \alpha_0, \dots, \alpha_n)$ be an n -G-map and $K_r = \{R_i\}_{0 \leq i \leq n-1}$ be a removal kernel in G . The n -G-map resulting of the removal of the cells of R is $G' = (\mathcal{D}', \alpha'_0, \dots, \alpha'_n)$ where:*

- (1) $\mathcal{D}' = \mathcal{D} \setminus R^*$;

- (2) $\forall d \in \mathcal{D}', d\alpha'_n = d\alpha_n$;
(3) $\forall i, 0 \leq i < n, \forall d \in \mathcal{D}', d\alpha'_i = d' = d(\alpha_i\alpha_{i+1})^k\alpha_i$ where k is the smallest integer such that $d' \in \mathcal{D}'$.

Notation 4 The n - G -map obtained after removal of a kernel $K_r = \{R_i\}_{0 \leq i \leq n}$ from an n - G -map G will be denoted either by $G \setminus K_r$, or by $G \setminus R^*$.

As stated by the next proposition, the involution α_n remains unchanged after the removal operation.

Proposition 11 Let G, G' be n - G -maps and $K_r = \{R_i\}_{0 \leq i \leq n}$ be a removal kernel as in Definition 21. Since $R_n = \emptyset$, then $d\alpha_n \in \mathcal{D}'$ for all $d \in \mathcal{D}'$.

Proof: It is readily seen that $d\alpha_n \in \mathcal{D}'$ for all $d \in \mathcal{D}'$. Indeed, suppose that $d\alpha_n \in \mathcal{C}_i \in R_i$ for some $i \in \{0, \dots, n-1\}$. In other words, $d\alpha_n$ belongs to an i -cell which is to be removed for $i < n$:

$$\mathcal{C}_i = \langle \alpha_0, \dots, \hat{\alpha}_i, \dots, \alpha_n \rangle (d\alpha_n) \in R_i, 0 \leq i < n$$

Since $i < n$, we deduce that $d\alpha_n\alpha_n = d$ also belongs to the above orbit, thus d belongs to the same i -cell of R_i . This is a contradiction with the fact that $d \in \mathcal{D}'$. \square

Remark 5 Let G, G' be n - G -maps and $K_r = \{R_i\}_{0 \leq i \leq n}$ be a removal kernel as in Definition 21. If a dart d belongs to an i -cell \mathcal{C} of R_i , then $d\alpha_n \in \mathcal{C}$. Indeed, since there are no n -cell in K_r , $i < n$ so that $d\alpha_i \in \langle \hat{\alpha}_i \rangle (d) = \mathcal{C}$.

The equivalence between the definitions 20 and 21 is stated by Proposition 12. The next two lemmas will be used in the proof of the proposition.

Lemma 14 Let $G = (\mathcal{D}, \alpha_0, \dots, \alpha_n)$ be an n - G -map and $K_r = \{R_i\}_{0 \leq i \leq n-1}$ be a removal kernel in G . Let $i \in \{0, \dots, n-1\}$ and $d \in R_i^*\alpha_i \setminus R_i^*$. If k is the smallest integer such that $d' = d(\alpha_i\alpha_{i+1})^k\alpha_i \in \mathcal{D} \setminus R^*$, then $k > 0$ and for all $0 \leq h < k$ we have $d(\alpha_i\alpha_{i+1})^h\alpha_i \in R_i^*$.

Proof: Let $\mathcal{D}' = \mathcal{D} \setminus R^*$. We first show that $k > 0$. Indeed, $d \in R_i^*\alpha_i \setminus R_i^*$ means that $d = b\alpha_i$ for some dart $b \in R_i^*$ so that $d\alpha_i = b\alpha_i\alpha_i = b \in R_i^*$. Therefore, $d\alpha_i \notin \mathcal{D}'$ so k cannot be equal to 0.

Then, we prove by recurrence on h , $0 \leq h < k$ that $d(\alpha_i\alpha_{i+1})^h\alpha_i \in R_i$, assuming that it does not belong to \mathcal{D}' since $h < k$. The property has already been shown to be true for $h = 0$.

Let us suppose that $d'' = d(\alpha_i\alpha_{i+1})^h\alpha_i$ belongs to R_i^* . Therefore, d'' belongs to a removed i -cell, say $\mathcal{C}_i = \langle \alpha_0, \dots, \hat{\alpha}_i, \dots, \alpha_n \rangle (d'')$. Because $i+1 \neq i$ we deduce that $d''\alpha_{i+1} = d(\alpha_i\alpha_{i+1})^h\alpha_i\alpha_{i+1} = d(\alpha_i\alpha_{i+1})^{h+1} \in \mathcal{C}_i \in R_i$. Now,

consider $d' = d(\alpha_i\alpha_{i+1})^{h+1}\alpha_i$ and suppose it does not belong to \mathcal{D}' ($h+1 < k$). There are two cases: either it belongs to R_i^* or it belongs to R_j^* , $j \neq i$. In the latter case we observe that $d(\alpha_i\alpha_{i+1})^{h+1}\alpha_i$ and $d(\alpha_i\alpha_{i+1})^{h+1}$ belong to the same j -cell. Therefore, $d(\alpha_i\alpha_{i+1})^{h+1}\alpha_i \in \mathcal{C}' \in R_j$ implies that $d(\alpha_i\alpha_{i+1})^{h+1} \in \mathcal{C}'$ which contradicts the fact that $d(\alpha_i\alpha_{i+1})^{h+1} \in \mathcal{C}_i \in R_i$ since cells to be removed are disjoint (Definition 19). Hence, $d(\alpha_i\alpha_{i+1})^{h+1}\alpha_i \in R_i$ and the property is true for $h+1$. \square

Lemma 15 *Let $G = (\mathcal{D}, \alpha_0, \dots, \alpha_n)$ be an n - G -map and $K_r = \{R_i\}_{0 \leq i \leq n-1}$ be a removal kernel in G . Let $\mathcal{D}' = \mathcal{D} \setminus R^*$, $i \in \{0, \dots, n-1\}$ and $BV_i = R_i^* \setminus R_i$. If $d \in \mathcal{D}' \setminus BV_i$ then $d\alpha_i \in \mathcal{D}'$.*

Proof: We need to prove that $d\alpha_i \notin R^*$ when $d \notin R^*$ and $d \notin BV_i$.

We first show that $d\alpha_i \notin R_i^*$. Indeed, if we suppose that $d\alpha_i \in R_i^*$, then $d\alpha_i\alpha_i = d \in R_i^*\alpha_i$. Since $d \notin R^*$, in particular $d \notin R_i^*$ and it follows that $d \in BV_i$ which is a contradiction, thus $d\alpha_i \notin R_i^*$.

We also prove that $d\alpha_i \notin R_j^*$ for all j , $j \neq i$. Indeed, if $d\alpha_i \in \mathcal{C}_j = \langle \alpha_0, \dots, \hat{\alpha}_j, \dots, \alpha_n \rangle(b)$ for $b \in R_j^*$ then since $i \neq j$, $d\alpha_i\alpha_i = d$ also belongs to \mathcal{C}_j . This is a contradiction with the fact that $d \in \mathcal{D}'$. Finally, we have $d\alpha_i \notin R^*$ so $d\alpha_i \in \mathcal{D}'$. \square

Proposition 12 *Definitions 20 and 21 are equivalent.*

Proof: We need to check that the involutions α'_i coincide in both definitions for all i , $0 \leq i \leq n$.

For $i = n$, only case (2) in Definition 20 applies and $\mathcal{D}' \setminus BV_n = \mathcal{D}'$ since $BV_n = \emptyset$. This point thus defines $b\alpha'_n = b\alpha_n$ for all $b \in \mathcal{D}'$ which is precisely point (2) of Definition 21.

It remains the case when $0 \leq i < n$. Let $d \in \mathcal{D}'$, we distinguish two cases:

1) If $d \notin BV_i$ then from Lemma 15 we have $d\alpha_i \in \mathcal{D}'$. Thus, $k = 0$ is the smallest integer such that $d' \in \mathcal{D}'$ in point (3) of Definition 21 so that $d\alpha'_i = d' = d\alpha_i$ is defined as in point (2) of Definition 20.

2) Next, we consider the case when $d \in BV_i$. We define

$$\begin{aligned} k_1 &= \min\{h \in \mathbb{N}^* \mid d(\alpha_i\alpha_{i+1})^h\alpha_i \in BV_i\} \\ k_2 &= \min\{h \in \mathbb{N}^* \mid d(\alpha_i\alpha_{i+1})^h\alpha_i \in \mathcal{D}'\} \end{aligned}$$

Since $BV_i \subset \mathcal{D}'$ (Corollary 3) we have $k_2 \leq k_1$.

From Lemma 14, we know that for all $0 \leq h < k_2$ we have $d(\alpha_i \alpha_{i+1})^h \alpha_i \in R_i^*$. In particular, $d(\alpha_i \alpha_{i+1})^{k_2-1} \alpha_i \in R_i^*$. Because applying α_{i+1} cannot send a dart from an i -cell to another i -cell we deduce that $d(\alpha_i \alpha_{i+1})^{k_2-1} \alpha_i \alpha_{i+1} = d(\alpha_i \alpha_{i+1})^{k_2} \in R_i^*$. Therefore, we have $d(\alpha_i \alpha_{i+1})^{k_2} \alpha_i \in R_i^* \alpha_i$. Now, because $d(\alpha_i \alpha_{i+1})^{k_2} \alpha_i \in \mathcal{D}'$ we thus have $d(\alpha_i \alpha_{i+1})^{k_2} \alpha_i \in R_i^* \alpha_i \cap \mathcal{D}'$ and from Corollary 3 we obtain that $d(\alpha_i \alpha_{i+1})^{k_2} \alpha_i \in BV_i$. It follows that $k_2 \geq k_1$.

Eventually, $k_1 = k_2$ so that point (3) of Definition 21 is equivalent to point (3) of Definition 20 when $d \in BV_i$. \square

Definition 22 (Cells removal in n -maps) *Let $M = (\mathcal{D}, \gamma_0, \dots, \gamma_{n-1})$ be an n -map and $S_r = \{R_i\}_{0 \leq i \leq n-1}$ a removal set in M . We define the $(n-1)$ -tuple $M \setminus S_r = (\mathcal{D}', \gamma'_0, \dots, \gamma'_{n-1})$ obtained after removal of the cells of S_r by:*

- $\mathcal{D}' = \mathcal{D} \setminus R^*$;
- $\forall i \in \{0, \dots, n-2\}, \forall d \in \mathcal{D}', d\gamma'_i = d(\gamma_i \gamma_{i+1}^{-1})^k \gamma_i$, where k is the smallest integer such that $d(\gamma_i \gamma_{i+1}^{-1})^k \gamma_i \in \mathcal{D}'$.
- For $i = n-1, \forall d \in \mathcal{D}', d\gamma'_{n-1} = d\gamma_{n-1}^{k+1}$ where k is the smallest integer such that $d\gamma_{n-1}^{k+1} \in \mathcal{D}'$.

We will prove in the sequel (Proposition 18) that the such defined $(n-1)$ -tuple $M \setminus S_r$ is actually an n -map if S_r is a removal kernel (Definition 19), this by establishing the link between removal in n -maps and removal in n -G-maps. Note that until this result has been proved, in the notation $M' = M \setminus K_r$, the prime indicates that M' is linked to a map but is not necessarily itself a map.

Proposition 13 *Let $M = (\mathcal{D}, \beta_n, \dots, \beta_1)$ be an n -map and $K_r = \{R_i\}_{0 \leq i \leq n-1}$ a removal set in M . The $(n-1)$ -tuple obtained after removal of the cells of R is $M' = (\mathcal{D}', \beta'_n, \dots, \beta'_1)$ defined by:*

- $\mathcal{D}' = \mathcal{D} \setminus R^*$;
- $\forall i \in \{1, \dots, n-1\}, \forall d \in \mathcal{D}', d\beta'_i = d\beta_1^k (\beta_i \beta_{i+1}^{-1})^{k'} \beta_i$, where k is the smallest integer such that $d\beta_1^k \notin R^*$ and k' is the smallest integer such that $d\beta_1^k (\beta_i \beta_{i+1}^{-1})^{k'} \beta_i \in \mathcal{D}'$.
- For $i = n, \forall d \in \mathcal{D}', d\beta'_n = d\beta_1^k \beta_n$ where k is the smallest integer such that $d\beta_1^k \beta_n \in \mathcal{D}'$.

Proof:

- For $i = n$, from Proposition 2 we have $\beta'_n = \gamma'_0$. By Definition 22 we know that for all $d \in \mathcal{D}'$, $d\beta'_n = d(\gamma_0 \gamma_1^{-1})^k \gamma_0$ where k is the smallest integer such that $d(\gamma_0 \gamma_1^{-1})^k \gamma_0 \in \mathcal{D}'$. We may rewrite $d\beta'_n = d\gamma_0 (\gamma_1^{-1} \gamma_0)^k$. From Proposition 2, $\gamma_0 = \beta_n$ and $\gamma_1^{-1} \gamma_0 = \beta_1^{-1}$, therefore $d\beta'_n = d\beta_n \beta_1^{-k}$. Since β'_n is an involution, $d\beta'_n = d\beta_n^{-1} = d\beta_1^k \beta_n^{-1}$. Again, $\beta_n = \beta_n^{-1}$ so that $d\beta'_n = d\beta_1^k \beta_n$.

- For $i = n - 1$, we have

$$\begin{aligned}
d\beta'_{n-1} &= d\gamma'_0\gamma'_{n-1} && \text{(Proposition 2)} \\
&= d(\gamma_0\gamma_1)^k\gamma_0\gamma_{n-1}^{h+1} && \text{(Definition 22)} \\
&= d\beta_1^k\beta_n(\beta_n\beta_{n-1})^{h+1} && \text{(Proposition 2)} \\
&= d\beta_1^k(\beta_{n-1}\beta_n)^h\beta_{n-1} && ((\beta_n\beta_{n-1})^{h+1} = \beta_n(\beta_{n-1}\beta_n)^h\beta_{n-1}) \\
&= d\beta_1^k(\beta_{n-1}\beta_n^{-1})^h\beta_{n-1} && (\beta_n = \beta_n^{-1})
\end{aligned}$$

- For $i \in \{1, \dots, n - 2\}$ and for all $d \in \mathcal{D}'$ we have

$$\begin{aligned}
d\beta'_i &= d\gamma'_0\gamma'_i && \text{(Proposition 2)} \\
&= d(\gamma_0\gamma_1)^k\gamma_0(\gamma_i\gamma_{i+1})^h\gamma_i && \text{(Definition 22)} \\
&= d(\gamma_0\gamma_1)^k\gamma_0(\gamma_i\gamma_{i+1}\gamma_0\gamma_0)^h\gamma_i \\
&= d(\gamma_0\gamma_1)^k(\gamma_0\gamma_i\gamma_{i+1}\gamma_0)^h\gamma_0\gamma_i \\
&= d\beta_1^k(\beta_i\beta_{i+1}^{-1})^h\beta_i && (\gamma_0\gamma_1 = \beta_1 \text{ and for all } i \in \{1, \dots, n - 2\}, \\
& && \gamma_0\gamma_i = \beta_i \text{ and } \gamma_{i+1}\gamma_0 = \beta_{i+1}^{-1})
\end{aligned}$$

□

Definition 23 Let G be an n - G -map, $S_r = \{R_i\}_{0 \leq i \leq n}$ be a removal set in G and $M = HV(G)$. We define the set $HV(S_r) = \{R'_i\}_{0 \leq i \leq n}$ as follows:

- $\forall i \in \{0, \dots, n - 1\}$, $R'_i = \{\langle \alpha_n\alpha_0, \dots, \alpha_n\hat{\alpha}_i, \dots, \alpha_n\alpha_{n-1} \rangle(d) \mid d \in R_i^*\}$
- $R'_n = \{\langle \alpha_0\alpha_1, \dots, \alpha_0\alpha_{n-1} \rangle(d) \mid \exists \mathcal{C} \in R_n, d \in \mathcal{C}\}$

Lemma 16 Let G be an n - G -map, $S_r = \{R_i\}_{0 \leq i \leq n}$ be a removal set in G and $M = HV(G)$. If $HV(S_r) = \{R'_i\}_{0 \leq i \leq n}$, we have $R^* = R'^*$.

Proof: The fact that $R^* \subset R'^*$ is immediate. Indeed, since $d \in \langle \alpha_n\alpha_0, \dots, \alpha_n\hat{\alpha}_i, \dots, \alpha_n\alpha_{n-1} \rangle(d)$, any dart of a cell of R_i (for $0 \leq i \leq n - 1$) belongs to R'_i .

On the other hand, for all $d \in \mathcal{D}$ and all $i \in \{0, \dots, n - 1\}$ we have

$$\langle \alpha_n\alpha_0, \dots, \alpha_n\hat{\alpha}_i, \dots, \alpha_n\alpha_{n-1} \rangle(d) \subset \langle \alpha_n, \dots, \hat{\alpha}_i, \dots, \alpha_{n-1}, \alpha_n \rangle(d) \quad (6)$$

From the definition of R'_i , if $E = \langle \alpha_n\alpha_0, \dots, \alpha_n\hat{\alpha}_i, \dots, \alpha_n\alpha_{n-1} \rangle(d) \in R'_i$ there exists an i -cell \mathcal{C} in R_i such that $d \in \mathcal{C}$. The i -cell of G that contains d is $\langle \alpha_n, \dots, \hat{\alpha}_i, \dots, \alpha_{n-1}, \alpha_n \rangle(d)$. From (6) we deduce that $E \subset \mathcal{C}$. Finally, $R'^* \subset R^*$. □

Lemma 17 *If G is an n -G-map and S_r is a removal set in G , then the set $HV(S_r)$ is a removal set in $HV(G)$.*

Proof: Let $G = (\mathcal{D}, \alpha_0, \dots, \alpha_n)$, according to Definition 5 $HV(G) = (\mathcal{D}, \delta_0 = \alpha_n \alpha_0, \dots, \delta_{n-1} = \alpha_n \alpha_{n-1})$.

From the definition of $HV(S_r)$, it is immediate that $R'_n = \emptyset$. Now, for all $i \in \{0, \dots, n-1\}$ and all $E \in R'_i$, we have $E = \langle \alpha_n \alpha_0, \dots, \alpha_n \hat{\alpha}_i, \dots, \alpha_n \alpha_{n-1} \rangle (d)$, for some dart $d \in \mathcal{D}$. Thus, E is an i -cell in $HV(G)$, from the very definition of i -cells in maps. It follows that $HV(S_r)$ is a removal set in $HV(G)$. \square

The next proposition is a first step to show that our definition of cells removal in n -maps is consistent with the one of removal in n -G-maps.

It remains to be proved that the removal operation, when applied to an n -map, produces a valid n -map as soon as the cells to be removed constitute a removal kernel according to Definition 19. (A consequence of Proposition 14 is that this is true when the map is the map of the hypervolumes of an n -G-map, not for any map.) This will be the purpose of Proposition 18.

Proposition 14 *If G is an n -G-map and K_r is a removal kernel in G , we have the following commutative diagram:*

$$\begin{array}{ccc} G & \xrightarrow{\text{removal of } K_r} & G' = G \setminus K_r \\ HV \downarrow & & HV \downarrow \\ M & \xrightarrow{\text{removal of } HV(K_r)} & M \setminus HV(K_r) \end{array}$$

In particular, $M \setminus HV(K_r)$ is an n -map.

Proof of Proposition 14: Let G, G' be the n -G-maps and K_r be the removal kernel as in Definition 21. By Lemma 17, $HV(K_r)$ is a proper removal set in $HV(G)$. If $M = HV(G)$, we want to prove that the n -map M'_1 obtained after removal of $HV(K_r)$ from M is precisely $M'_2 = HV(G')$, the map of hypervolumes of $G' = G \setminus K_r$.

Let us write $K_r = \{R_i\}_{0 \leq i \leq n}$ and $S_r = HV(K_r) = \{R'_i\}_{0 \leq i \leq n}$.

Let $\mathcal{D}' = \mathcal{D} \setminus R^*$. (By Lemma 16, $\mathcal{D}' = \mathcal{D} \setminus R^*$). We have:

- $G = (\mathcal{D}, \alpha_0, \dots, \alpha_n)$;
- $G' = (\mathcal{D}', \alpha'_0, \dots, \alpha'_n)$ where α'_i for $0 \leq i \leq n$ follows Definition 21;
- $M = HV(G) = (\mathcal{D}, \gamma_0 = \alpha_n \alpha_0, \dots, \gamma_{n-1} = \alpha_n \alpha_{n-1})$, from Definition 5;
- $M'_2 = HV(G') = (\mathcal{D}', \gamma''_0 = \alpha'_n \alpha'_0, \dots, \gamma''_{n-1} = \alpha'_n \alpha'_{n-1})$, from Definition 5;
- $M'_1 = (\mathcal{D}', \gamma'_0, \dots, \gamma'_{n-1})$ is the n -map obtained after removal of cells of R from M (following Definition 22).

We need to prove that for all $i \in \{0, \dots, n-1\}$ and for all $d \in \mathcal{D}'$, $b\gamma'_i = b\gamma''_i$ which will eventually show that $M'_1 = M'_2$.

Let $d \in \mathcal{D}'$ and $i \in \{0, \dots, n-1\}$.

If $i \leq n-2$, following Definition 22, $d\gamma'_i = d(\gamma_i\gamma_{i+1}^{-1})^k\gamma_i$ where k is the smallest integer such that $d(\gamma_i\gamma_{i+1}^{-1})^k\gamma_i \notin R^*$. Since $\gamma_i = \alpha_n\alpha_i$ for $0 \leq i \leq n-1$ we obtain:

$$d\gamma'_i = d(\alpha_n\alpha_i(\alpha_n\alpha_{i+1})^{-1})^k\alpha_n\alpha_i = d(\alpha_n\alpha_i\alpha_{i+1}\alpha_n)^k\alpha_n\alpha_i$$

Since $\alpha_n^2 = 1_{\mathcal{D}}$ the latter equality becomes:

$$d\gamma'_i = d\alpha_n(\alpha_i\alpha_{i+1})^k\alpha_i$$

On the other hand $\gamma''_i = \alpha'_n\alpha'_i$. According to Definition 21 we have for any dart $b \in \mathcal{D}'$, $b\alpha'_n = b\alpha_n$ and $b\alpha'_i = b' = b(\alpha_i\alpha_{i+1})^r\alpha_i$ where r is the smallest integer such that $b' \in \mathcal{D}'$. Eventually, we have $d\gamma''_i = d\gamma'_i$.

If $i = n-1$ then $d\gamma'_{n-1} = d\gamma_{n-1}^{k+1}$ where k is the smallest integer such that $d\gamma_{n-1}^{k+1} \in \mathcal{D}'$. Since $\gamma_{n-1} = \alpha_n\alpha_{n-1}$ we have

$$d\gamma'_{n-1} = d(\alpha_n\alpha_{n-1})^{k+1} = d\alpha_n(\alpha_{n-1}\alpha_n)^k\alpha_{n-1}$$

On the other hand $\gamma''_{n-1} = \alpha'_n\alpha'_{n-1}$ where α'_{n-1} is defined for all $b \in \mathcal{D}'$ by $b\alpha'_{n-1} = b' = b(\alpha_{n-1}\alpha_n)^r\alpha_{n-1}$ where r is the smallest integer such that $b' \in \mathcal{D}'$. Again, since $d\alpha'_n = d\alpha_n$ (Definition 21) we have $d\gamma''_{n-1} = d\alpha_n(\alpha_{n-1}\alpha_n)^r\alpha_{n-1}$. Eventually, $d\gamma''_{n-1} = d\alpha_n(\alpha_{n-1}\alpha_n)^r\alpha_{n-1} = d\gamma'_{n-1}$. \square

Definition 24 (Associated removal set) *If $M = (\mathcal{D}, \gamma_0, \dots, \gamma_{n-1})$ is an n -map and $K_r = \{R_i\}_{i=0, \dots, n}$ is a removal kernel in M . Let $\tilde{G} = AG(M) = (\tilde{\mathcal{D}}, \alpha_0, \dots, \alpha_n)$ be an associated n -G-map of M . We define the removal set $\tilde{K}_r = \{\tilde{R}_i\}_{i=0, \dots, n}$ in \tilde{G} as follows:*

$$\forall i \in \{0, \dots, n-1\}, \tilde{R}_i = \{\tilde{\mathcal{C}} \mid \mathcal{C} \in R_i\}$$

where $\tilde{\mathcal{C}}$, for any cell \mathcal{C} of M , is the associated cell of \mathcal{C} in $AG(M)$ (Definition 17).

As stated by Proposition 15, the removal set introduced in the previous definition is in fact a removal kernel.

Lemma 18 *If \mathcal{C}_1 and \mathcal{C}_2 are disjoint cells in M , then $\tilde{\mathcal{C}}_1$ and $\tilde{\mathcal{C}}_2$ are disjoint cells of $AG(M)$.*

Proof: Following Definition 17 and the notations of Definition 7:

- If \mathcal{C}_1 and \mathcal{C}_2 are both i -cells with $i < n$ we have $\tilde{\mathcal{C}}_1 = \mathcal{C}_1 \cup \mathcal{C}_1\sigma$ and $\tilde{\mathcal{C}}_2 = \mathcal{C}_2 \cup \mathcal{C}_2\sigma$. Since $\mathcal{C}_1 \cap \mathcal{C}_2 = \emptyset$ and σ is one-to-one, it follows that $\mathcal{C}_1\sigma \cap \mathcal{C}_2\sigma = \emptyset$. Now, for any cell $\mathcal{C} \subset \mathcal{D}$ and $\mathcal{C}\sigma \subset \mathcal{D}'$ with $\mathcal{D} \cap \mathcal{D}' = \emptyset$. It follows that $\mathcal{C}_1 \cap \mathcal{C}_2\sigma = \mathcal{C}_2 \cap \mathcal{C}_1\sigma = \emptyset$. Eventually, we obtain $\tilde{\mathcal{C}}_1 \cap \tilde{\mathcal{C}}_2 = \emptyset$.
- If \mathcal{C}_1 is an i -cell with $i < n$ and \mathcal{C}_2 is an n -cell we have $\tilde{\mathcal{C}}_1 = \mathcal{C}_1 \cup \mathcal{C}_1\sigma$ and $\tilde{\mathcal{C}}_2 = \mathcal{C}_2 \cup \mathcal{C}_2\gamma_0\sigma$, the same arguments apply since $\gamma_0\sigma$ is one-to-one and $\mathcal{C}\gamma_0\sigma \subset \mathcal{D}'$ for all cells \mathcal{C} of M .
- Same considerations apply if \mathcal{C}_1 and \mathcal{C}_2 are both n -cell.

□

Proposition 15 *The removal set \tilde{K}_r in Definition 24 is a removal kernel in $AG(M)$.*

Proof: Since K_r is a removal kernel, by Proposition 8 all cells of \tilde{K}_r have a local degree 2 and by Proposition 9 they are regular. By Lemma 18, if two cells of K_r are disjoint then their associated cells (in_r) are disjoint too. Thus, \tilde{K}_r is a removal kernel in $AG(M)$ according to Definition 19. □

Definition 25 (Associated removal kernel) *Let M be an n -map and $AG(M)$ be an associated G -map of M . If K_r is a removal kernel in M , the set \tilde{K}_r (Definition 24) is called the removal kernel associated with K_r in $AG(M)$ (following Proposition 15).*

Definition 26 (Removal set restriction) *If $S_r = \{R_i\}_{0 \leq i \leq n}$ is a removal set in an n -map M and \mathcal{D}' is a connected component of M , we denote by $S_{r|\mathcal{D}'}$ the removal set that contains all the cells of S_r included in \mathcal{D}' .*

Remark 6 *In Definition 26, since \mathcal{D}' is a connected component, a cell of S_r is included in \mathcal{D}' as soon as one of its darts belongs to \mathcal{D}' . Indeed, any cell of $\langle \gamma_0, \dots, \gamma_{n-1} \rangle(d)$ belongs to the same connected component of M as d .*

Proposition 16 *If M is an n -map, K_r is a removal set in M , and \mathcal{D}' is a connected component of M , we have the following diagram:*

$$\begin{array}{ccc}
 M & \xrightarrow{\text{removal of } K_r} & M \setminus K_r \\
 \downarrow |_{\mathcal{D}'} & & \downarrow |_{\mathcal{D}'} \\
 M' & \xrightarrow{\text{removal of } K_{r|\mathcal{D}'}} & M' \setminus K_{r|\mathcal{D}'}
 \end{array}$$

Proof: Following Remark 3 and Definition 8, $M' = M|_{\mathcal{D}'}$ and the sub-map of $M \setminus K_r$ induced by \mathcal{D}' are both n -maps.

We now have to prove that the diagram commutes. Let us denote:

$$\begin{aligned} M &= (\mathcal{D}, \gamma_0, \dots, \gamma_{n-1}), M' = (\mathcal{D}', \gamma_{0|\mathcal{D}'}, \dots, \gamma_{n-1|\mathcal{D}'}); \\ M \setminus K_r &= (\mathcal{D}'', \gamma''_0, \dots, \gamma''_{n-1}); \text{ and} \\ M' \setminus K_{r|\mathcal{D}'} &= (\mathcal{D}''', \gamma'''_0, \dots, \gamma'''_{n-1}). \end{aligned}$$

We show that for all $i \in \{0, \dots, n-1\}$, $\gamma_i''' = \gamma_i''_{|\mathcal{D}'}$.

Let $K_r = \{R_j\}_{0 \leq j \leq n-1}$ and $K_{r|\mathcal{D}'} = \{R'_j\}_{0 \leq j \leq n-1}$. Furthermore, let $i \in \{0, \dots, n-1\}$ and $d \in \mathcal{D}'$.

In the definition of $d\gamma_i'''$ (Definition 22), $d(\gamma_{i|\mathcal{D}'}\gamma_{i+1|\mathcal{D}'}^{-1})^k\gamma_{i|\mathcal{D}'}$ ($d\gamma_{n-1}^{k+1}_{|\mathcal{D}'}$ when $i = n-1$) belongs to $\mathcal{D}' \setminus R^*$ iff it belongs to $\mathcal{D} \setminus R^*$.

Indeed, let us denote $d' = d(\gamma_{i|\mathcal{D}'}\gamma_{i+1|\mathcal{D}'}^{-1})^k\gamma_{i|\mathcal{D}'}$ (resp. $d\gamma_{n-1}^{k+1}_{|\mathcal{D}'}$).

($d' \in \mathcal{D}' \setminus R^* \Rightarrow d' \in \mathcal{D} \setminus R^*$) If $d' \in \mathcal{D}' \setminus R^*$, in particular $d' \in \mathcal{D}$ so we have to show that $d' \notin R^*$. Now, if b is a dart of a cell of R (i.e. $d \in R^*$) such that $d \in \mathcal{D}'$, the fact that \mathcal{D}' is a connected component implies that the cell that contains b is itself included in R (Remark 6), thus it also belongs to R' from the very definition of $K_{r|\mathcal{D}'}$. Therefore, we have $R^* \cap \mathcal{D}' \subset R'^* \cap \mathcal{D}'$. It follows that $d' \notin R'^*$ implies $d' \notin R^*$.

($d' \in \mathcal{D} \setminus R^* \Rightarrow d' \in \mathcal{D}' \setminus R^*$) Since $d' \in \mathcal{D}'$, $d' \in \mathcal{D} \setminus R^*$ iff $d' \in \mathcal{D}' \setminus R^*$ and the implication is straightforward since $R'^* \subset R^*$.

It follows that $d\gamma_i''' = d\gamma_i''$ when $d \in \mathcal{D}'$, thus $\gamma_i'''_{|\mathcal{D}'} = \gamma_i''_{|\mathcal{D}'}$. Eventually, we obtain that $(M \setminus K_r)_{|\mathcal{D}'} = M' \setminus K_{r|\mathcal{D}'}$. \square

Notation 5 Let M be an n -map and K_r be a removal kernel in M . If $G = AG(M)$ is an associated n - G -map of M , we may define a set \tilde{K}_r as follows:

$$\tilde{K}_r = \{ \tilde{R}_i \mid R_i \in K_r \}$$

where

$$\forall i \in \{0, \dots, n-1\}, \tilde{R}_i = \{ \tilde{\mathcal{C}} \mid \mathcal{C} \in K_r \}$$

and $\tilde{\mathcal{C}}$, for any cell \mathcal{C} of M , is the associated cell of \mathcal{C} in $AG(M)$ (Definition 17).

Proposition 17 If K_r is a removal kernel in M and $G = AG(M)$ is an associated G -map of M , then the set \tilde{K}_r (Notation 5) is a removal kernel in $AG(M)$.

Proof: By Proposition 9 and Proposition 8, if \mathcal{C} is a regular i -cell with local degree 2 in M , then $\tilde{\mathcal{C}}$ is a regular i -cell with local degree 2 in $AG(M)$. Furthermore, since the map σ of Definition 7 is onto, it is readily seen that if \mathcal{C}_1 and \mathcal{C}_2 are two disjoint cells of M , then $\tilde{\mathcal{C}}_1$ and $\tilde{\mathcal{C}}_2$ are disjoint cells of $AG(M)$. It follows that \tilde{K}_r is a proper removal kernel in $AG(M)$. \square

Lemma 19 *Let $M = (\mathcal{D}, \gamma_0, \dots, \gamma_{n-1})$ be an n -map and $S_r = \{R_i\}_{0 \leq i \leq n}$ be a removal set in M . If \tilde{S}_r is the associated removal set of S_r in $AG(M)$, we have*

$$S_r = HV(\tilde{S}_r)|_{\mathcal{D}}$$

Proof: Let us denote $\tilde{G} = AG(M) = (\tilde{\mathcal{D}} = \mathcal{D} \cup \mathcal{D}', \alpha_0, \dots, \alpha_n)$ following Definition 7, and $\tilde{S}_r = \{\tilde{R}_i\}_{0 \leq i \leq n}$ the associated removal set of S_r in $AG(M)$.

(\subset) Let \mathcal{C} be an i -cell in R and $b \in \mathcal{C}$. From the very definition of the i -cell $\tilde{\mathcal{C}}$ associated to \mathcal{C} in $AG(M)$ and from the definition of \tilde{S}_r , we have $b \in \tilde{\mathcal{C}} \in \tilde{R}_i$.

From Definition 23 there is a cell \mathcal{C}' in $HV(\tilde{S}_r)$ that contains b , being a particular orbit of b . As a cell of $HV(AG(M))$, since $b \in \mathcal{D}$, the cell \mathcal{C}' belongs to $HV(\tilde{S}_r)|_{\mathcal{D}}$. Since $M = HV(AG(M))|_{\mathcal{D}}$ (Proposition 5) the i -cell \mathcal{C}' is an i -cell of M . From $b \in \mathcal{C} \cap \mathcal{C}'$ we then deduce that $\mathcal{C} = \mathcal{C}'$ so that \mathcal{C} is an i -cell of $HV(\tilde{S}_r)|_{\mathcal{D}}$.

(\supset) Let $d \in \mathcal{C}' \in HV(\tilde{S}_r)|_{\mathcal{D}}$. From Definition 23 there exists an i -cell $\tilde{\mathcal{C}} \in \tilde{R}$ and a dart $d \in \tilde{\mathcal{C}}$ such that \mathcal{C}' is a particular orbit of d in $AG(M)$; in particular $d \in \mathcal{C}'$.

Following the definition of \tilde{S}_r , the cell $\tilde{\mathcal{C}}$ is associated to an i -cell $\mathcal{C} \in R$. Note that, from Definition 17, $\tilde{\mathcal{C}} \cap \mathcal{D} = \mathcal{C}$. As $d \in \mathcal{C}' \subset \mathcal{D}$ and $d \in \tilde{\mathcal{C}}$ we obtain that $d \in \mathcal{C}$.

Finally, we have $d \in \mathcal{C} \cap \mathcal{C}'$. Since $M = HV(AG(M))|_{\mathcal{D}}$ (Proposition 5) the i -cell \mathcal{C}' of $HV(\tilde{S}_r)|_{\mathcal{D}}$ is an i -cell of M . It follows that \mathcal{C}' is an i -cell of R . \square

Proposition 18 *If M is an n -map and K_r is a removal kernel in M , the $(n+1)$ -tuple $M \setminus K_r$ as defined by Definition 22 is a valid n -map.*

Proof: With $\tilde{G} = AG(M)$, we have the following diagram:

$$\begin{array}{ccccc}
 M & \longrightarrow & M & \xrightarrow{\text{removal of } K_r} & M \setminus K_r \\
 \downarrow & & \uparrow |_{\mathcal{D}} & & \uparrow |_{\mathcal{D}} \\
 AG \downarrow & & HV(\tilde{G}) & \xrightarrow{\text{removal of } HV(\tilde{K}_r)} & HV(\tilde{G}) \setminus HV(\tilde{K}_r) \\
 \downarrow & & \uparrow HV & & \uparrow HV \\
 \tilde{G} & \longrightarrow & \tilde{G} & \xrightarrow{\text{removal of } \tilde{K}_r} & \tilde{G} \setminus \tilde{K}_r
 \end{array}$$

Indeed:

- We have $HV(\tilde{G})|_{\mathcal{D}} = M$ by Proposition 5. Hence the left part of the dia-

gram.

- If K_r is a removal kernel in M , then \tilde{K}_r as defined in Definition 25 is a removal kernel in \tilde{G} by Proposition 15. Thus the bottom-right part of the diagram holds by Proposition 14.
- We have $K_r = HV(\tilde{K}_r)_{|\mathcal{D}}$ by Lemma 19. Thus, the upper-right part of the diagram is valid by Proposition 16.

Eventually, if we follow the path

$$M \xrightarrow{AG} \tilde{G} \xrightarrow{\setminus K_r} \tilde{G} \setminus \tilde{K}_r \xrightarrow{HV} HV(\tilde{G} \setminus \tilde{K}_r) \xrightarrow{|\mathcal{D}} M \setminus K_r$$

we deduce that $M \setminus K_r$ is a valid n -map since $\tilde{G} = AG(M)$ is an n -G-map (by Proposition 4), therefore $\tilde{G} \setminus \tilde{K}_r$ is an n -G-map [3,4], hence $HV(\tilde{G} \setminus \tilde{K}_r)$ is an n -map [8], and finally $HV(\tilde{G} \setminus \tilde{K}_r)_{|\mathcal{D}}$, that is $M \setminus K_r$, is an n -map following Remark 3 and Definition 8. \square

3.2 Cells contraction

Definition 27 (Contraction kernel) Let $G = (\mathcal{D}, \alpha_0, \dots, \alpha_n)$ be an n -G-map and $K_c = \{C_i\}_{0 \leq i \leq n}$ be sets of i -cells with $C_0 = \emptyset$. Let $C = \cup_{i=0}^n C_i$. Furthermore, we suppose that the cells of C are disjoint (i.e. $\forall c, c' \in C, c \cap c' = \emptyset$) and that all of them are regular cells with dual local degree 2. The family of sets K_c is then called a contraction kernel in G .

We also denote:

$$C_i^* = \bigcup_{c \in C_i} c \text{ and } C^* = \bigcup_{i \in \{0, \dots, n\}} C_i^*$$

A contraction kernel is defined in a similar way for an n -map M .

Remark 7 If G is an n -G-map, then from the very definition of cells (Definition 9) an i -cell in G is an $(n-i)$ -cell in \overline{G} .

Proposition 19 If G is an n -G-map, a contraction kernel K_c in G is a removal kernel in \overline{G} .

Proof: If $G = (\mathcal{D}, \alpha_0, \dots, \alpha_n)$ we may write $\overline{G} = (\mathcal{D}, \overline{\alpha}_0, \dots, \overline{\alpha}_n)$ with $\overline{\alpha}_i = \alpha_{n-i}$ for all $i \in \{0, \dots, n\}$. Thus, for any dart $d \in \mathcal{D}$ and any $i \in \{0, \dots, n\}$ we have $\mathcal{C}_i(d) = \langle \alpha_0, \dots, \hat{\alpha}_i, \dots, \alpha_n \rangle(d) = \langle \overline{\alpha}_n, \dots, \hat{\overline{\alpha}}_{n-i}, \dots, \overline{\alpha}_0 \rangle(d)$.

It follows that the set of n -cells of K_c in G , which is empty, is precisely a set of 0-cells in \overline{G} .

From Definitions 9, 12, and 6 it is also readily seen that an i -cell of degree 2 in G is an $(n - i)$ -cell of dual degree 2 in \overline{G} . \square

The following definition is adapted from [5] where a definition combining removals and contractions was given. The definition below is obtained by considering that no cell is to be removed.

Definition 28 (Cells contraction in n -G-maps [5]) *Let $G = (\mathcal{D}, \alpha_0, \dots, \alpha_n)$ be an n -G-map and $K_c = \{C_i\}_{1 \leq i \leq n}$ a contraction kernel in G . Let $BV_i = C_i^* \alpha_i \setminus C_i^*$, $\forall i, 0 \leq i \leq n$. The set BV_i is called the set of surviving darts which are neighbors of an i -cell to be contracted. The n -G-map resulting of the contraction of the cells of C is $G' = (\mathcal{D}', \alpha'_0, \dots, \alpha'_n)$ defined by:*

- (1) $\mathcal{D}' = \mathcal{D} \setminus C^*$;
- (2) $\forall i, 0 \leq i \leq n, \forall b \in \mathcal{D}' \setminus BV_i, b\alpha'_i = b\alpha_i$;
- (3) $\forall i, 0 < i \leq n, \forall b \in BV_i, b\alpha'_i = b' = b(\alpha_i \alpha_{i-1})^k \alpha_i$ where k is the smallest integer such that $b' \in BV_i$.

In this paper, we choose to define the contraction operation in G-maps as a removal operation in the dual map (Definition 29 below). The equivalence between this definition and the one (Definition 28) given by Grasset in [5] or by Damiand and Lienhardt in [3] will be stated by Proposition 22.

Definition 29 (Cells contraction in n -G-maps) *Let $G = (\mathcal{D}, \alpha_0, \dots, \alpha_n)$ be an n -G-map and $K_c = \{C_i\}_{1 \leq i \leq n}$ be a contraction kernel. The n -G-map resulting of the contraction of the cells of K_c is $G' = \overline{\overline{G} \setminus K_c}$.*

Notation 6 *The n -G-map obtained after the contraction of a kernel $K_c = \{C_i\}_{0 \leq i \leq n}$ from an n -G-map G will be denoted either by G/K_c , or by G/C^* .*

Proposition 20 *Let G, G' be n -G-maps and $K_c = \{C_i\}_{0 \leq i \leq n}$ be a contraction kernel as in Definition 29. Since $C_0 = \emptyset$, then $d\alpha_0 \in \mathcal{D}'$ for all $d \in \mathcal{D}'$.*

Proof: It is readily seen that $d\alpha_0 \in \mathcal{D}'$ for all $d \in \mathcal{D}'$. Indeed, suppose that $d\alpha_0 \in \mathcal{C}_i \in C_i$ for some $i \in \{1, \dots, n\}$. In other words, $d\alpha_0$ belongs to an i -cell which is to be removed for $i > 0$. Since $i > 0$, the orbit that defines \mathcal{C}_i obviously contains $b\alpha_0$ for all $b \in \mathcal{C}_i$ (Definition 9). Therefore, $d\alpha_0\alpha_0 = d$ also belongs to \mathcal{C}_i . This is a contradiction with the fact that $d \in \mathcal{D}'$. \square

Proposition 21 *Let $G = (\mathcal{D}, \alpha_0, \dots, \alpha_n)$ be an n -G-map and $K_c = \{C_i\}_{1 \leq i \leq n}$ be a contraction kernel. The n -G-map resulting of the contraction of the cells of C according to Definition 29 is $G' = (\mathcal{D}', \alpha'_0, \dots, \alpha'_n)$ defined by:*

- (1) $\mathcal{D}' = \mathcal{D} \setminus C$;
- (2) $\forall d \in \mathcal{D}', d\alpha'_0 = d\alpha_0$;

(3) $\forall i, 0 < i \leq n, \forall d \in \mathcal{D}', d\alpha'_i = d' = d(\alpha_i\alpha_{i-1})^k\alpha_i$ where k is the smallest integer such that $d' \in \mathcal{D}'$.

Proof: Let $\overline{G} = (\mathcal{D}, \overline{\alpha}_0, \dots, \overline{\alpha}_n)$ with $\overline{\alpha}_i = \alpha_{n-i}$ for $0 \leq i \leq n$. From Proposition 19, K_c is a removal kernel in \overline{G} and we denote $G' = \overline{G} \setminus K_c$. Thus, from Definition 21 $G' = (\mathcal{D}', \overline{\alpha}''_0, \dots, \overline{\alpha}''_n)$ where:

- $\mathcal{D}'' = \mathcal{D} \setminus C$;
- $\forall d \in \mathcal{D}', d\overline{\alpha}''_n = \overline{\alpha}_n$;
- $\forall i, 0 \leq i < n, \forall d \in \mathcal{D}', d\overline{\alpha}''_i = d' = (\overline{\alpha}_i\overline{\alpha}_{i+1})^k\overline{\alpha}_i$ where k is the smallest integer such that $d' \in \mathcal{D}''$.

Now, let us denote $G/K_c = G' = (\mathcal{D}', \alpha'_0, \dots, \alpha'_n)$ following Definition 29. Since $G' = \overline{G}'$ we have $\alpha'_i = \overline{\alpha}''_{n-i}$ for $0 \leq i \leq n$. Therefore, we obtain:

- $\forall d \in \mathcal{D}', d\alpha'_0 = d\overline{\alpha}''_n = \overline{\alpha}_n$;
- $\forall i, 0 < i \leq n, \forall d \in \mathcal{D}', d\alpha'_i = d\overline{\alpha}''_{n-i} = d' = d(\overline{\alpha}_{n-i}\overline{\alpha}_{n-(i-1)})^k\overline{\alpha}_{n-i}$ where k is the smallest integer such that $d' \in \mathcal{D}''$.

or again, since $\alpha_i = \overline{\alpha}_{n-i}$ for $0 \leq i \leq n$,

- $\forall d \in \mathcal{D}', d\alpha'_0 = \alpha_0$;
- $\forall i, 0 < i \leq n, \forall d \in \mathcal{D}', d\alpha'_i = d\overline{\alpha}''_{n-i} = d' = d(\alpha_i\alpha_{i-1})^k\alpha_i$ where k is the smallest integer such that $d' \in \mathcal{D}''$.

Which is precisely the definition of α'_i for $0 \leq i \leq n$ in Proposition 21. \square

Proposition 22 *Definition 28 and 29 are equivalent.*

Proof: Let $G = (\mathcal{D}, \alpha_0, \dots, \alpha_n)$ be an n -G-map and $K_c = \{C_i\}_{1 \leq i \leq n}$ a contraction kernel in G .

We first express $G/K_c = \overline{\overline{G} \setminus K_c}$, following Definition 29. Thus, let us write $\overline{G} = (\mathcal{D}, \overline{\alpha}_0, \dots, \overline{\alpha}_n)$ where $\overline{\alpha}_i = \alpha_{n-i}$ for $0 \leq i \leq n$. From Proposition 19, K_c is a removal kernel in \overline{G} which contains no n -cell of \overline{G} . Then, let $\overline{G}' = \overline{G} \setminus K_c = (\mathcal{D}', \overline{\alpha}'_0, \dots, \overline{\alpha}'_n)$ be the map obtained after removal of K_c from \overline{G} . From Definition 20, \overline{G}' is defined by:

- (1) $\mathcal{D}' = \mathcal{D} \setminus C^*$;
- (2) $\forall i, 0 \leq i \leq n, \forall b \in \mathcal{D}' \setminus BV_i, b\overline{\alpha}'_i = b\overline{\alpha}_i$;
- (3) $\forall i, 0 \leq i < n, \forall b \in BV_i, b\overline{\alpha}'_i = b' = b(\overline{\alpha}_i\overline{\alpha}_{i+1})^k\overline{\alpha}_i$ where k is the smallest integer such that $b' \in BV_i$.

Now, let $G'' = G/K_c = \overline{\overline{G}' \setminus K_c} = \overline{\overline{G}'}$. We denote $G'' = (\mathcal{D}', \alpha''_0, \dots, \alpha''_n)$ with $\alpha''_i = \overline{\alpha}'_{n-i}$ for all $i \in \{0, \dots, n\}$. From the above definition of $\overline{\alpha}'_i$, $0 \leq i \leq n$ we obtain:

- (1) $\mathcal{D}' = \mathcal{D} \setminus C^*$;
- (2) $\forall i, 0 \leq i \leq n, \forall b \in \mathcal{D}' \setminus BV_i, b\alpha_i'' = b\bar{\alpha}_{n-i}$;
- (3) $\forall i, 0 < i \leq n, \forall b \in BV_i, b\alpha_i'' = b' = b(\bar{\alpha}_{n-i}\bar{\alpha}_{(n-i)+1})^k\bar{\alpha}_{n-i}$ where k is the smallest integer such that $b' \in BV_i$.

Using the relation $\bar{\alpha}_{n-i} = \alpha_i$ for $0 \leq i \leq n$, we deduce:

- (1) $\mathcal{D}' = \mathcal{D} \setminus C^*$;
- (2) $\forall i, 0 \leq i \leq n, \forall b \in \mathcal{D}' \setminus BV_i, b\alpha_i'' = b\alpha_i$;
- (3) $\forall i, 0 < i \leq n, \forall b \in BV_i, b\alpha_i'' = b' = b(\alpha_i\alpha_{i-1})^k\alpha_i$ where k is the smallest integer such that $b' \in BV_i$.

This definition of α_i'' for $0 \leq i \leq n$ is precisely the one given by Definition 28 for the n -G-map obtained after contraction of K_c from G . \square

Definition 30 (Cells contraction in n -maps) *Let $M = (\mathcal{D}, \gamma_0, \dots, \gamma_{n-1})$ be an n -map and let $K_c = \{C_i\}_{1 \leq i \leq n}$ be a contraction kernel. The n -map resulting of the contraction of the cells of K_c , which we denote M/K_c is the n -map $\overline{\overline{M}} \setminus K_c$.*

The following proposition provides the justification for the definition of cells contraction in n -maps.

Proposition 23 *We have the following commutative diagram:*

$$\begin{array}{ccc}
 G & \xrightarrow{\text{contraction of } K_c} & G' = G/K_c \\
 HV \downarrow & & HV \downarrow \\
 M & \xrightarrow{\text{contraction of } HV(K_c)} & M' = M/K_c
 \end{array}$$

Proof: The diagram is a consequence of the one below, which comes from Proposition 1, Proposition 14 and Definition 29.

$$\begin{array}{ccccccc}
 G & \xrightarrow{\text{dual}} & \overline{G} & \xrightarrow{\text{removal of } K_c} & \overline{G} \setminus K_c & \xrightarrow{\text{dual}} & \overline{\overline{G} \setminus K_c} = \overline{\overline{G}}/K_c = G/K_c \\
 HV \downarrow & & HV \downarrow & & HV \downarrow & & HV \downarrow \\
 M & \xrightarrow{\text{dual}} & \overline{M} & \xrightarrow{\text{removal of } HV(K_c)} & \overline{M} \setminus K_c & \xrightarrow{\text{dual}} & \overline{\overline{M} \setminus K_c} = \overline{\overline{M}}/K_c = M/K_c \\
 & (1) & & (2) & & (3) &
 \end{array}$$

Indeed, parts (1) and (3) of the above diagram were stated by Proposition 1. Part (2) is precisely the diagram of Proposition 14. Eventually, the equalities $\overline{\overline{G} \setminus K_c} = \overline{\overline{G}}/K_c$ and $\overline{\overline{M} \setminus K_c} = \overline{\overline{M}}/K_c$ follow Definition 29. \square

Proposition 24 *Let $M = (\mathcal{D}, \gamma_0, \dots, \gamma_{n-1})$ be an n -map. Let $K_c = \{C_i\}_{1 \leq i \leq n}$ be a contraction kernel. The n -map obtained after contraction of the cells of K_c , $M' = (\mathcal{D}', \gamma'_0, \dots, \gamma'_{n-1})$ is defined by:*

- $\mathcal{D}' = \mathcal{D} \setminus C$;
- $\forall d \in \mathcal{D}'$, $d\gamma'_0 = d\gamma_{n-1}^k \gamma_0$ where k is the smallest integer such that $d\gamma_{n-1}^k \gamma_0 \in \mathcal{D}'$;
- $\forall i \in \{1, \dots, n-1\}$, $\forall d \in \mathcal{D}'$, $d\gamma'_i = d\gamma_{n-1}^k (\gamma_i \gamma_{i-1}^{-1})^{k'} \gamma_i$, where k is the smallest integer such that $d\gamma_{n-1}^k \in \mathcal{D}'$ and k' is the smallest integer such that $d\gamma_{n-1}^k (\gamma_i \gamma_{i-1}^{-1})^{k'} \gamma_i \in \mathcal{D}'$.

Proof: The n -map obtained after the contraction of the cells in K_c in M is $M' = \overline{M} \setminus K_c$.

Let $\overline{M} = (\mathcal{D}, \overline{\gamma}_0 = \gamma_0^{-1}, \overline{\gamma}_1 = \gamma_0^{-1} \gamma_{n-1}, \dots, \overline{\gamma}_{n-1} = \gamma_0^{-1} \gamma_1)$ (Definition 6) and let $M'' = \overline{M} \setminus K_c$, if we denote $M'' = (\mathcal{D}'', \gamma''_0, \dots, \gamma''_{n-1})$, according to Definition 22 and the above notations we have:

- $\mathcal{D}'' = \mathcal{D} \setminus R^*$;
- $\forall i \in \{0, \dots, n-2\}$, $\forall d \in \mathcal{D}'$, $d\gamma''_i = d(\overline{\gamma}_i \overline{\gamma}_{i+1}^{-1})^k \overline{\gamma}_i$, where k is the smallest integer such that $d(\overline{\gamma}_i \overline{\gamma}_{i+1}^{-1})^k \overline{\gamma}_i \in \mathcal{D}'$.
- For $i = n-1$, $\forall d \in \mathcal{D}'$, $d\gamma''_{n-1} = d\overline{\gamma}_{n-1}^{k+1}$ where k is the smallest integer such that $d\overline{\gamma}_{n-1}^{k+1} \in \mathcal{D}'$.

Since $M' = \overline{M''}$, by Definition 6 we have

$$M' = (\mathcal{D}', \gamma'_0 = \gamma''_0, \gamma'_1 = \gamma''_0 \gamma''_{n-1}, \dots, \gamma'_{n-1} = \gamma''_0 \gamma''_1)$$

Thus,

- For $i = 0$, $d\gamma'_0 = d\gamma''_0 = d(\overline{\gamma}_0 \overline{\gamma}_1^{-1})^k \overline{\gamma}_0 = d(\gamma_0^{-1} \gamma_{n-1}^{-1} \gamma_0)^k \gamma_0^{-1} = d\gamma_0^{-1} \gamma_{n-1}^{-k}$. Since γ'_0 is an involution, we have

$$d\gamma'_0 = d\gamma_0'^{-1} = d(\gamma_0^{-1} \gamma_{n-1}^{-k})^{-1} = d\gamma_{n-1}^k \gamma_0 \quad (7)$$

- For $i = 1$,

$$\begin{aligned} d\gamma'_1 &= d\gamma''_0 \gamma''_{n-1} = d\gamma_{n-1}^k \gamma_0 \overline{\gamma}_{n-1}^{h+1} && \text{(from (7))} \\ &= d\gamma_{n-1}^k \gamma_0 (\gamma_0^{-1} \gamma_1)^{h+1} \\ &= d\gamma_{n-1}^k \gamma_0 \gamma_0^{-1} (\gamma_1 \gamma_0^{-1})^h \gamma_1 \\ &= d\gamma_{n-1}^k (\gamma_1 \gamma_0^{-1})^h \gamma_1 \end{aligned}$$

- For $i \in \{2, \dots, n-1\}$,

$$\begin{aligned}
d\gamma'_i &= d\gamma''_0 \gamma''_{n-i} = d\gamma_{n-1}^k \gamma_0 (\bar{\gamma}_{n-i} \bar{\gamma}_{(n-i)+1}^{-1})^h \bar{\gamma}_{n-i} \\
&= d\gamma_{n-1}^k \gamma_0 (\gamma_0^{-1} \gamma_i \gamma_{i-1}^{-1} \gamma_0)^h \gamma_0^{-1} \gamma_i \\
&= d\gamma_{n-1}^k \gamma_0 \gamma_0^{-1} (\gamma_i \gamma_{i-1}^{-1})^h \gamma_i \\
&= d\gamma_{n-1}^k (\gamma_i \gamma_{i-1}^{-1})^h \gamma_i
\end{aligned}$$

□

Proposition 25 *Let $M = (\mathcal{D}, \beta_1, \dots, \beta_n)$ be an n -map. Let $K_c = \{C_i\}_{1 \leq i \leq n}$ be a contraction kernel. The n -map obtained after contraction of the cells of K_c , $M' = (\mathcal{D}', \beta'_1, \dots, \beta'_n)$ is equivalently defined by:*

- $\mathcal{D}' = \mathcal{D} \setminus C$;
- For $i = 1, \forall d \in \mathcal{D}'$, $d\beta'_1 = d\beta_1^{k+1}$, where k is the smallest integer such that $d\beta_1^{k+1} \in \mathcal{D}'$.
- $\forall i \in \{2, \dots, n\}, \forall d \in \mathcal{D}'$, $d\beta'_i = d(\beta_i \beta_{i-1}^{-1})^k \beta_i$, where k is the smallest integer such that $d(\beta_i \beta_{i-1}^{-1})^k \beta_i \in \mathcal{D}'$.

Proof: We use the definition of the contraction in M as a removal of K_c in the dual map \overline{M} . Following Proposition 2, we will denote

$$M_1 = \overline{M} = (\mathcal{D}, \beta_n \stackrel{\text{not.}}{=} \overline{\gamma_0}, \dots, \beta_1 \stackrel{\text{not.}}{=} \overline{\gamma_{n-1}}) \quad (8)$$

From Definition 30, $M' = M/K_c = \overline{\overline{M} \setminus K_c}$. Let $M'_1 = \overline{M} \setminus K_c = (\mathcal{D}, \overline{\gamma}'_0, \dots, \overline{\gamma}'_{n-1})$. From Definition 22, the involutions $\overline{\gamma}'_i$ are defined by

- $d\overline{\gamma}'_i = d(\overline{\gamma}_i \overline{\gamma}_{i+1}^{-1})^k \overline{\gamma}_i$ for $i \in \{0, \dots, n-2\}$, and
- $d\overline{\gamma}'_{n-1} = d\overline{\gamma}_{n-1}^{k+1}$ if $i = n-1$.

With the notations of Proposition 2 we obtain:

- $d\beta'_{(n-i)} = d(\beta_{(n-i)} \beta_{(n-i)-1}^{-1})^k \beta_{(n-i)}$ for $i \in \{0, \dots, n-2\}$, and
- $d\beta'_1 = d\beta_1^{k+1}$ if $i = 1$.

where $(n-i) \in \{2, \dots, n\}$ when $i \in \{0, \dots, n-2\}$. □

4 Conclusion and perspectives

We have defined cells removal and contraction in combinatorial maps, based on the previous work by Damiand and Lienhardt for generalized maps.

A logical sequel of this paper will be the definition of n -dimensional combinatorial pyramids and the related notions, the way Brun and Kropatch [1] did in the two-dimensional case and following the works of Grasset [5] about pyramids of generalized maps.

References

- [1] L. Brun, W. Kropatsch, Combinatorial pyramids, in: Suvisoft (ed.), IEEE International conference on Image Processing (ICIP), vol. II, IEEE, Barcelona, 2003.
- [2] G. Damiand, Définition et étude d'un modèle topologique minimal de représentation d'images 2D et 3D, Thèse de doctorat, Université Montpellier II (Décembre 2001).
- [3] G. Damiand, P. Lienhardt, Removal and contraction for n -dimensional generalized maps, in: Proceedings of 11th Discrete Geometry for Computer Imagery, vol. 2886 of Lecture Notes in Computer Science, Naples, Italy, 2003.
- [4] G. Damiand, P. Lienhardt, Removal and contraction for n -dimensional generalized maps, technical report (2003).
- [5] C. Grasset-Simon, Définition et étude des pyramides généralisées nD : application pour la segmentation multi-échelle d'images 3d, Thèse de doctorat, Université de Poitiers (2006).
- [6] C. Grasset-Simon, G. Damiand, P. Lienhardt, nD generalized map pyramids: Definition, representations and basic operations, Pattern Recognition 39 (4) (2006) 527–538.
- [7] P. Lienhardt, Topological models for boundary representation: a comparison with n -dimensional generalized maps, Computer-Aided Design 23 (1) (1991) 59–82.
- [8] P. Lienhardt, N -dimensional generalized combinatorial maps and cellular quasi-manifolds, International Journal of Computational Geometry & Applications 4 (3) (1994) 275–324.