



**HAL**  
open science

## Model predictive control for an infrared drying process of a water based epoxy amine painting

Pascal Dufour, Denise Blanc, Youssefi Touré, Pierre Laurent

► **To cite this version:**

Pascal Dufour, Denise Blanc, Youssefi Touré, Pierre Laurent. Model predictive control for an infrared drying process of a water based epoxy amine painting. International Drying Symposium (IDS), Aug 2002, Beijing, China. pp. 1147-1154. hal-00353067v2

**HAL Id: hal-00353067**

**<https://hal.science/hal-00353067v2>**

Submitted on 22 Jan 2009

**HAL** is a multi-disciplinary open access archive for the deposit and dissemination of scientific research documents, whether they are published or not. The documents may come from teaching and research institutions in France or abroad, or from public or private research centers.

L'archive ouverte pluridisciplinaire **HAL**, est destinée au dépôt et à la diffusion de documents scientifiques de niveau recherche, publiés ou non, émanant des établissements d'enseignement et de recherche français ou étrangers, des laboratoires publics ou privés.

**This document must be cited according to its final version  
which is published in a conference proceeding as:  
P. Dufour<sup>1</sup>, D. Blanc<sup>2</sup>, Y. Touré<sup>3</sup>, P. Laurent<sup>1</sup>,  
" Model predictive control for an infrared drying process  
of a water based epoxy amine painting",  
Proceedings of the 13<sup>th</sup> International Drying Symposium (IDS) 2002,  
vol. B, pp. 1147-1154,  
Beijing, PRC, august 27-30, 2002.  
<http://hal.archives-ouvertes.fr/DUFOUR-PASCAL-C-3926-2008>**

**All open archive documents of Pascal Dufour are available at:  
<http://hal.archives-ouvertes.fr/DUFOUR-PASCAL-C-3926-2008>**

**The professional web page (Fr/En) of Pascal Dufour is:  
<http://www.lagep.univ-lyon1.fr/signatures/dufour.pascal>**

1

Université de Lyon, Lyon, F-69003, France; Université Lyon 1;  
CNRS UMR 5007 LAGEP (Laboratoire d'Automatique et de GENie des Procédés),  
43 bd du 11 novembre, 69100 Villeurbanne, France  
Tel +33 (0) 4 72 43 18 45 - Fax +33 (0) 4 72 43 16 99  
<http://www.lagep.univ-lyon1.fr/> <http://www.univ-lyon1.fr> <http://www.cnrs.fr>

2

INSA de Lyon;  
LAEPSI (Laboratoire d'Analyse Environnementale des Procédés et des Systèmes Industriels);  
Bâtiment Said Carnot, 9 rue de la Physique  
69621 Villeurbanne cedex, France  
<http://laepsi.insa-lyon.fr/>

3

Université d'Orléans,  
UPRES EA 2078 LVR (Laboratoire de Vision et de Robotique ),  
63 Av de Lattre de Tassigny, 18020 Bourges Cedex, France  
<http://www.bourges.univ-orleans.fr/rech/lvr/>

# Model Predictive Control for an Infrared Drying Process of a Water Based Epoxy Amine Painting

Dufour P.<sup>1</sup>, Blanc D.<sup>2</sup>, Touré Y.<sup>3</sup> and Laurent P.<sup>1</sup>

<sup>1</sup> LAGEP UMR CNRS 5007, University Claude Bernard Lyon 1,  
43 bd du 11 Novembre 1918, 69622 Villeurbanne Cedex, France

<sup>2</sup> LAEPSI, INSA Lyon,  
Bât Sadi Carnot, 9 rue de la Physique, 69621 Villeurbanne Cedex, France

<sup>3</sup> LVR UPRES EA 2078, University of Orléans,  
63 avenue de Lattre de Tassigny, 18020 Bourges cedex, France

## Abstract

This paper deals with the experimental control of an infrared drying process of a water based epoxy-amine painting. This approach is based on a unidirectional diffusional modeling of infrared drying phenomena where both heat and mass transfers under shrinkage conditions are accounted for. The control problem is concerned with the tracking of any given trajectory for one of the characteristics (i.e the temperature or the mean water content) during the drying cycle. This is solved using the well known model predictive control framework where the nonlinear diffusional model is directly used in the control formulation. Experimental results show the efficiency of the trajectory tracking. This method can be extended for more general constrained control problem.

**Keywords:** drying process, heat transfer, mass transfer, model predictive control.

## 1 Introduction

Reactive painting drying is an important industrial problem through its impact for the quality of the final aspect of products in many industries (cars, preglass paint sheets, cans, etc.). The main difficulty encountered during this operation is the evacuation of the solvent. This solvent is needed to simultaneously build the painting film and to ensure the film polymerization but should be avoided to be trapped in the final dried product. Until now, the use of volatile organic compounds (VOC) allowed the control of this evacuation during the polymerization reactions. But the enforced laws concerning environment lead now to replace the use of VOC by the use of water based solvent that evacuates less rapidly and at higher temperatures than VOC. To overcome this problem, infrared drying has been widely developed in industrial processes. Some studies (Okazaki et al., 1974 ; Vrentas and Vrentas, 1994) dealt with diffusion problems with both infrared and water used as solvent.

The problem treated here is dealing with the on-line control of the drying cycle. A control strategy has to be developed and has to be able to be implementable for on-line control, taking into account of natural physical limitations or specifications (constraints) inherent to any process. An advanced model based control strategy is well dedicated to solve this constrained problem: model predictive control (MPC). MPC or receding horizon control refers to a class of control algorithms in which a dynamic process model is used to predict and optimize process performance. The idea is to solve, at each sample time, an open-loop optimization problem over a finite prediction horizon in order to find the value of the manipulated variable that has to be implemented. The procedure is reiterated at the next sample time with the update of process measurements. Historically, two MPC strategies were first developed in the 1970's and permit to define the MPC paradigm. In 1986, the second generation was able to handle output constraints. Today, MPC has become an advanced control strategy widely used in industry (Eder, 1999). Indeed, MPC is well suited for high performance control since constraints can be explicitly incorporated into the formulation of the control problem. Therefore, it is not a surprise to see that it is an important tool for control

engineers where plant being controlled are sufficiently slow for its implementation: indeed, one has to be able to solve an on-line optimization problem. More details and references on MPC can be found in (Qin and Badgwell, 1996 ; Mayne et al., 2000).

The paper is organized as follow: first, the first-principles diffusional model obtained in a previous work is briefly described. Then, the MPC strategy is detailed. Finally, experimental results are shown.

## **2 Knowledge-based modelling**

### **2.1 Painting formulation and characteristics**

Due to the great complexity of industrial paintings, the experiments are realized using a water based epoxy-amine painting formulated in our laboratory. This permitted us to experimentally determined every physical, thermal and chemical properties (Blanc et al., 1997). The painting film is composed of two elements:

- a resin constituted of an "oil in water" emulsion of DGEBA (Diglycidylether of Bisphenol A) which condensation index is equal to 0.15,
- a hardener composed of a primary triamine soluble in water. Currently used in the painting industry, it is named Jeffamine T403.

During the experiments, this painting film is coated in low thickness (between 30 and 300  $\mu\text{m}$ ) on an iron substrate (also named the support), that has been first classically treated at its surface like in the automobile industry. The painting characteristics and support characteristics can be found in details in (Blanc et al., 1997). During the drying, two phenomena occur: the solvent vaporization (the water in the present case) and the reticulation. Given the dynamic of these phenomena (respectively about 100s for the vaporization and about 100min for the reticulation in the present experimental conditions), the reticulation phenomena is not taken into account in this work. Thus, drying characteristics depend only on the temperature and the humidity. Moreover, a non negligible deformation of the film happens during the drying due to water content (40% of the humidity in dry basis). Given the low sample thickness with respect to its surface, this deformation phenomena is characterized by the sample thickness variation.

### **2.2 Infrared Dryer**

The near infrared panel curing dryer used during the experiments was previously described in details (Blanc et al., 1998). The instrument part is composed of a pyrometer that allows the on-line temperature measurement of the sample at the upper surface and a precision balance that allows the follow-up of the sample and support set mean mass. The accuracy of the chosen balance is 0.001g since the water loss mass is in the order of 0.4 g for a total mass about 100g (painting plus support). The infrared panel is composed of 9 quartz lamps with a tungsten filament used in the wave length about 1.2  $\mu\text{m}$  that allows to obtain over the sample flow densities that range between 0 and 12  $\text{kW}/\text{m}^2$ .

### **2.3 Drying modelling**

The dynamic model of the painting film sample infrared drying is characterized by the assumed uniform temperature  $T$  and by the humidity  $X$  in dry basis. The temperature is assumed to be constant due the low thickness of the sample and due to the thermal characteristics of the support. This assumption has been experimentally checked. The partial differential equation (PDE) model  $S_{NL}$  is deduced from the following mass and energy balances.

### **2.4 Mass transfer**

In the case of shrinking material, assuming an unidirectional transfer along the thickness  $z$ , the transfer of the solvent is diffusional and convective. In an eurlian (fixed) framework  $(z,t)$ , this transfer is function of the solid deformation rate. By introducing a lagrangian (mobile) framework  $(\xi,t)$ , this leads to write the diffusion equation of the solvent as follow (Blanc et al., 1998):

$$\frac{\partial X(\xi,t)}{\partial t} = \frac{\partial}{\partial \xi} \left( \frac{D}{(1+\beta^* X)^2} \frac{\partial X}{\partial \xi} \right)$$

One has introduced the new independent space variables  $\xi$  to account for the shrinkage phenomena assumed to be characterized by a linear relation:

$$\frac{d\xi}{dz} = \frac{1}{1+\beta^* X}$$

The initial condition is, at  $t=0$  and for  $0 \leq \xi \leq \delta_{dry}$ ,  $X(\xi,t) = X_i$  and the two boundary conditions are:

- $\forall t > 0$  and at  $\xi = 0$ :

$$\frac{\partial X(\xi,t)}{\partial \xi} = 0$$

- $\forall t > 0$  and at  $\xi = \delta_{dry}$ :

$$\dot{m}(\bar{X}, T) = - \frac{D \rho_d}{(1+\beta^* X)^2} \frac{\partial X}{\partial \xi}$$

where  $\dot{m}(\bar{X}, T)$ , the drying rate, is expressed by the film theory (Bird et al., 1960) and  $\bar{X}$  is the mean humidity in dry basis. As reported in the literature for polymeric solutions (Okazaki, 1974), it is assumed that the mass diffusion coefficient varies with the temperature and with the humidity content according to the relation:

$$D = D_0 \exp\left(-\frac{Ea}{\tilde{R}T}\right) \exp\left(-\frac{a'}{X}\right)$$

where  $D_0$  represents the pre-exponential factor,  $Ea$  is the activation energy and  $a'$  is the humidity parameter.

## 2.5 Heat transfer

Due to the small painting film thickness and due to the great thermal heat diffusivity of the iron support, the temperature of the whole system (painting film + support) is assumed to be uniform. Consequently and neglecting the heat due to the reaction, an overall heat balance accounting for the radiative and the convective heat losses and the evaporation losses (Fig. 1) leads to:

$$(\rho_p c_{pp} \delta_p + \rho_s c_{ps} \delta_s) \frac{dT(t)}{dt} = \alpha_{ir}(\bar{X}) \dot{q} - h_c(T - T_h) - \sigma_h(T^4 - T_h^4) - h_c(T - T_b) - \alpha_s \sigma(T^4 - T_b^4) - l_v(T) \dot{m}(\bar{X}, T)$$

with the initial condition  $T(t=0)=T_i$  and where the infrared flow  $\dot{q}(t)$  is the manipulated variable.

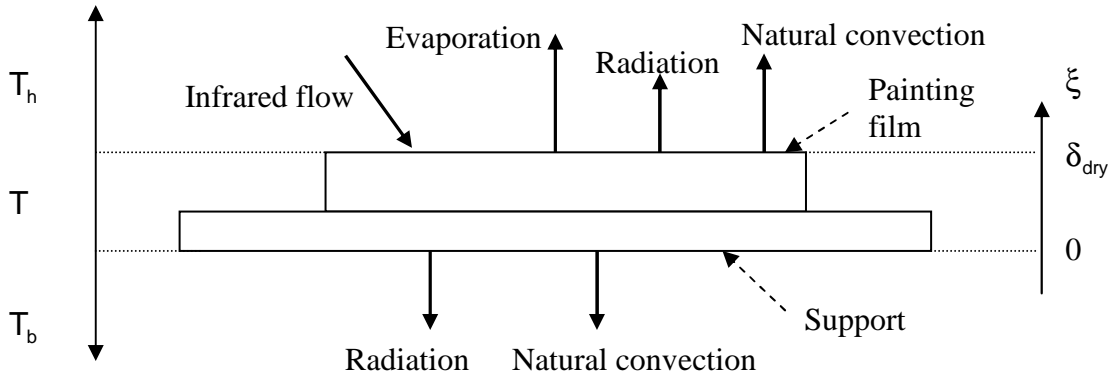

Figure 1: Thermal Flows.

### 3 Process Control Strategy

#### 3.1 Control Problem

At the end of the drying cycle, the final product obtained as to be usable: bubbles and fissures phenomena that can happen during the polymerization reaction have therefore to be avoided. To ensure the final product quality, paint producers propose to track a reference temperature trajectory during the drying cycle in order to extract water as best as possible before polymerization reactions starts. Therefore, the control problem considered here is to allow the process controlled variable (i.e. the temperature or the mean humidity in dry basis) to track any kind of time-varying reference trajectory. Due to the lack of space, only experimental results for the temperature tracking will be shown. This leads to determine on-line the process manipulated variable (i.e. the infrared flow) to apply during the drying cycle. Moreover, process physical limitations concerning the magnitude and the velocity of the manipulated variable have to be taken into account in the problem resolution.

#### 3.2 Model Predictive Control Strategy

In a previous work (Larabi et al., 2000), we have introduced the model predictive control (MPC) strategy to solve this trajectory tracking. The control problem is then stated as an on-line optimization problem over a receding horizon  $N_p$  where the performance index  $J$  to be minimized reflects the trajectory tracking task. Since the problem will be solved numerically, a mathematical discrete time formulation is given. The tracking objective can be written as the initial constrained optimization problem at the actual discrete time  $k$ :

$$\left\{ \begin{array}{l} \min_{\tilde{u}} J(\tilde{u}) = \sum_{j=k+1}^{j=k+N_p} [y_{ref}(j) - y_p(j)]^2 \\ \tilde{u} = [u(k) = \dot{q}(k) \dots u(j) = \dot{q}(j) \dots u(k + N_c - 1) = \dot{q}(k + N_c - 1)] \\ \text{and } \forall j \in \{k + N_c, \dots, k + N_p - 1\}: u(j) = u(k + N_c - 1) \\ \text{subject to constraints on the manipulated variable :} \\ u_{min} \leq u(j) \leq u_{max} \quad \forall j \in \{k + 1, k + N_p\} \\ \Delta u_{min} \leq u(j) - u(j - 1) \leq \Delta u_{max} \quad \forall j \in \{k + 1, k + N_p\} \end{array} \right.$$

In this formulation, it is first to notice that in the performance index  $J$  expression, the knowledge of the process output  $y_p$  is required over the prediction horizon  $N_p$  (i.e. for future times). These informations are obviously not available at the present time  $k$ , but this problem can be overcome using the IMC structure. In this structure, the manipulated variable is applied to both the process and its model. This structure allows to reformulate the tracking problem:

$$y_{\text{ref}}(j) - y_p(j) = y_d(j) - y_m(j) = (y_{\text{ref}}(j) - e(j)) - y_m(j)$$

**Assumption:** (Morari and Zafiriou, 1983)

*The error  $e$  between the process output  $y_p$  and the model output  $y_m$  remains constant over the prediction horizon  $N_p$ . The error value is updated at each sampled time  $k$  thanks to new measurements from the plant.*

According to this assumption and with the IMC structure, the performance index  $J$  to be minimized can be expressed as:

$$J(\tilde{u}) = \sum_{j=k+1}^{j=k+N_p} ((y_{\text{ref}}(j) - e(k)) - y_m(j))^2$$

where the model is introduced into the control algorithm. From a practical point of view, the second problem is the computational time aspect. Indeed, as it can be seen in the new performance index formulation, the model aims to predict the future dynamic behavior of the process output over a finite prediction horizon  $N_p$  and therefore has to be solved on-line. To reduce the on-line nonlinear PDE model resolution time, we use a linearization method (Friedly, 1972) of the nonlinear model  $S_{NL}$  about a similar nonlinear model  $S_0$  computed off-line by choosing its input  $u_0$  (Larabi et al., 2000). Finally, the off-line solved nonlinear model  $S_0$  and the on-line solved linearized model  $S_{TVL}$  replace the initial nonlinear model  $S_{NL}$  as depicted Fig. 2.

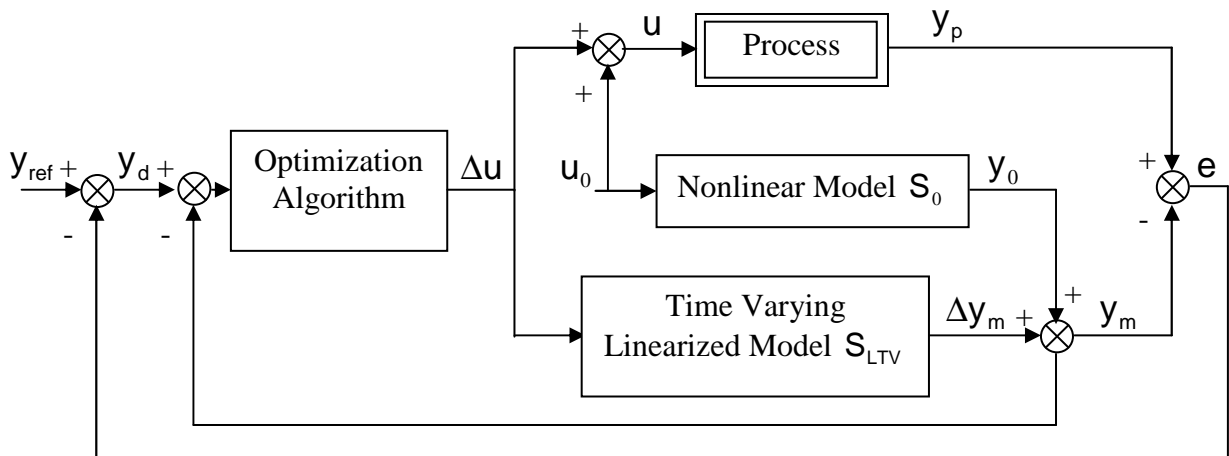

Figure 2: Time Varying Linearized Internal Model Control (TVLIMC) structure.

The control objective is now to find the variation  $\Delta u$  of the manipulated variable  $u$  about a chosen trajectory  $u_0$  leading to the best optimization result. A constrained optimization problem including an on-line resolution of the linear model  $S_{LTV}$  has therefore to be solved (Larabi et al., 2000). The last point is concerned with the way to handle input constraints: this is done replacing the constrained parameter  $\Delta \tilde{u}$  by an unconstrained parameter  $\Delta \tilde{p}$  through a simple hyperbolic transformation (Fletcher, 1987 ; Larabi et

al., 2000) that uses the constraints bounds. Output constraints can also be accounted for through an exterior penalty method (Fletcher, 1987). The optimizer argument is now an unconstrained argument and any unconstrained optimization algorithm can be used to solve the final on-line penalized optimization problem: widely known and used for its robustness and convergence properties, we apply the Levenberg-Marquardt's algorithm (Fletcher, 1987), where the parameter  $\Delta\tilde{\mathbf{p}}$  are determined at each sample time  $k$  using the model prediction and the process measurement.

## 4 Experimental results

In this first attempts, the control horizon  $N_c$  is tuned to 1: It allows to minimize the on-line computational time. Experiments have been realized to point out the influence of the control tuning parameter  $N_p$  over the tracking performance.

### 4.1 Operating Conditions

The operating conditions are the following one:

- the linearization about  $S_0$  is performed with  $u_0=5000$  W/m<sup>2</sup> and with the initial conditions  $T_i=36$  °C and  $X_i=0.4$  kg/kg,
- the value for the sampling period  $T_s$  is 1s,
- constraints bounds are:  $u_{\max}=12,000$  W/m<sup>2</sup>,  $u_{\min}=0$  W/m<sup>2</sup>,  $\Delta u_{\max}=500$  W/m<sup>2</sup>,  $\Delta u_{\min}=-500$  W/m<sup>2</sup>,
- atmospheric conditions are:  $X_{\text{air}} = 20$  %,  $T_h = 52$  °C,  $T_b = 20$  °C,
- the control algorithm, written in Fortran code, has been combined to C code in order to realize the interface with the sensors and the actuator,
- the processor rate is 400 MHz.

In order to compare results for any value of  $N_p$ , one introduces the normalized cost function  $J' = \frac{J}{N_p}$ .

### 4.2 Temperature Reference Trajectory Tracking

From Fig. 3, one can see that the tracking objective is correctly achieved in all cases.

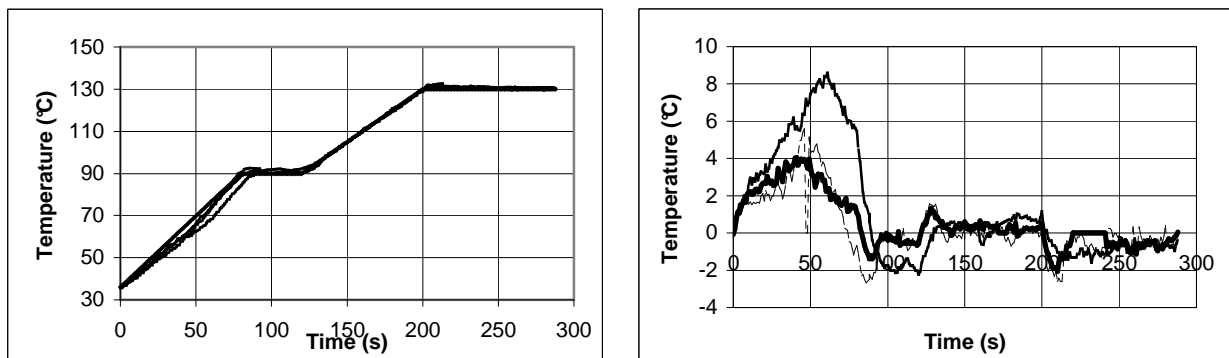

Figure 3: Temperature trajectory tracking (left) and tracking error (right) for  $N_p=3$  (dotted), 6 (solid), 12 (dashed).

Moreover, the intermediate value  $N_p=6$  for the horizon prediction gives the best result:



- with a small prediction horizon ( $N_p=3$ ), the discontinuities handling (around  $k=80, 120$  and  $200$ ) is less efficient than with  $N_p=6$  as confirmed by the values taken by the normalized cost function. In this case, informations quantity available describing the future process behavior are insufficient. In a way, with  $N_p=3$ , the problem is badly stated for its resolution, as we can see on the applied control: when the three discontinuities points appear, the infrared flow is always either saturated in magnitude or in velocity (Fig. 4). The optimizer does not correctly capture the future behavior of the process. Then, the algorithm tends too often to find a non admissible solution and to do bang-bang control. This leads consequently to poor tracking performances ;

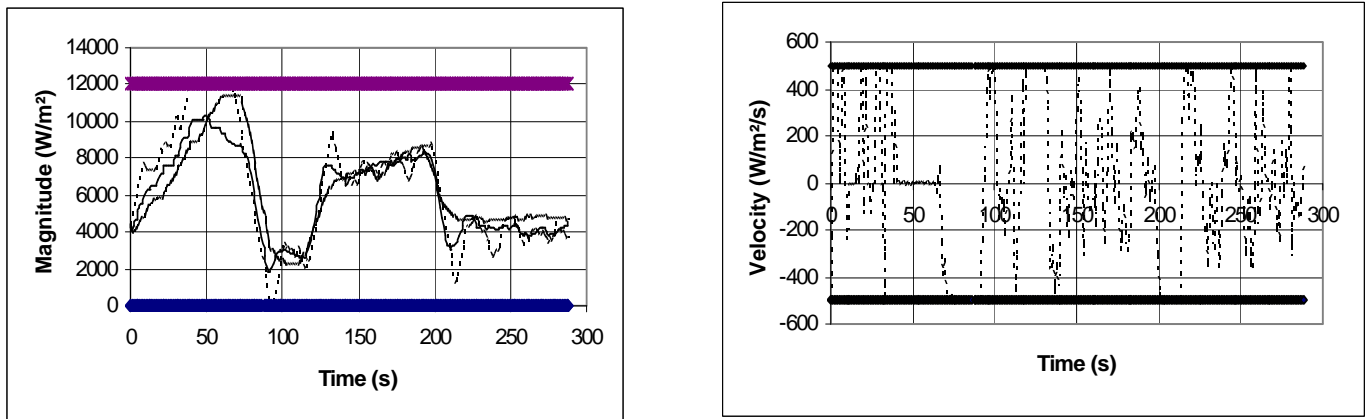

Figure 4: Magnitude (left) for  $N_p=3$  (dotted), 6 (solid), 12 (dashed) and velocity (right) for  $N_p=3$  (dotted) for the infrared flow.

- increasing the prediction horizon value to 6 and 12, the infrared flow becomes more and more smooth (Fig. 4), but with a big prediction horizon ( $N_p=12$ ), another problem appears for  $0 \leq k \leq 80$ : the model, qualitatively true, is quantitatively false. Since more values calculated by the model resolution are taken into account in the optimization problem, the criteria minimization is less efficient than in the case where the prediction horizon take an average value for ( $N_p=6$ ). This is confirm when tuning  $N_p$  to values higher than 12.

Therefore, the prediction horizon value  $N_p=6$  is the "optimal" choice for this main parameter:  $N_p$ : tuned to 5, 7, 8, 9, 10 or 11 it was giving less interesting results.

## 5 Conclusion

In this paper, an efficient approach for the on-line control of an infrared drying process has been shown. The model predictive control approach uses a diffusional model leading to the knowledge of the drying characteristics, i.e the temperature and mass content. To allow the on-line application of this method, the nonlinear diffusional model is first solved off-line. Adjustments in the infrared flow to apply are then computed on-line using a linearized model involved in the constrained optimization problem. The final tracking experimental results are very interesting. It shows that this two-phases MPC approach allows to determine a physically applicable infrared flow. The influence of the MPC tuning parameter, i.e the prediction horizon, has been point out even if the results are acceptable is all cases. Moreover, since the balance measurements can be very noisy, a new approach is under study for a better humidity set points tracking: it is concerned with a soft sensing approach where both the model and the unnoisy temperature measurements are needed instead of the balance measurements. Moreover, since any objective function can be stated, one could introduce a new one that handle directly the final properties of the product.

## 6 Bibliography

Bird, R.B., Stewart, W.E. & Lighfoot, E.N.,1960, Transport Phenomena., John Wiley and Sons.

Blanc, D., Laurent, P. & Andrieu J.,1998, Modeling of the Reactive Infrared Drying of a Model Water-based Epoxy-amine Painting Coated on Iron Support with Experimental Validation, Proc. of the 11th IHTC, 5, 181-186.

Blanc, D., Laurent, P., Andrieu, J. & Gerard, J.F.,1997, Convective and Radiant IR Curing of Bulk and Waterborne Epoxy Coating as Thin Layers. Part I: methodology, Polymer Eng. and Science, 37 (12), 1959-1969.

Eder, H.H., 1999, MBPC Benefits and Key Success Factors, Proc. of the European Control Conference, Paper F1033-6.

Fletcher, R. 1987, Practical Methods of Optimization, John Wiley and Sons.

Friedly, J.C.,1972, Dynamic Behavior of Processes, Prentice-Hall, Inc.

Larabi, M.C., Dufour, P., Laurent, P. & Touré Y., 2000, Predictive Control of a Nonlinear Distributed Parameter System: Real Time Control of a Painting Film Drying Process, Proc. of the MTNS conference, Paper B167.

Marquis, P. & Broustail, J.P., 1988, SMOC, a Bridge between State Space and Model Predictive Controllers: Application to the Automation of a Hydrotreating Unit, Proc. of the IFAC Workshop on Model Based Process Control, 37-43.

Mayne, D.Q., Rawlings, J.B., Rao, C.V. & Sokaert, P.O.M., 2000, Constrained Model Predictive Control: Stability and Optimality, Automatica, 36(6), 789-814.

Morari, M. & Zafiriou, E. 1983, Robust Control, Dunod.

Okazaki, M., Shioda, K., Masuda, K. & Toei, R., 1974, Drying Mechanism of Coated Film of Polymer Solution., Journal of Chem. Eng. of Japan, 7(2), 99-105.

Qin, S.J., & Badgwell, T.A., 1996, An Overview of Industrial Model Predictive Control Technology. Proc. of the Fifth International Conference on Chemical Process Control, 232-256.

Vrentas, J.S. & Vrentas, C.M.,1994, Drying of Solvent-coated Polymer Films, Journal of Polymer Science: Part B: Polymer Physics, 32, 187-194.