

**This document must be cited according to its final version
which is published in a conference proceeding as:
P. Dufour, S. Bhartiya, T.J. English,
E.P. Gaztke, P.S. Dhurjati, F.J. Doyle III,
"Faults detection of the continuous pulp digester",
Proceedings of the 4th IFAC Workshop on on-line fault detection and super
vision in the chemical process industries (CHEMFAS - 4),
pp. 106-111,
Seoul, South Korea,
june 7-8, 2001**

**All open archive documents of Pascal Dufour are available:
<http://hal.archives-ouvertes.fr/DUFOUR-PASCAL-C-3926-2008>**

**The list of Pascal Dufour's works published in journals are available:
<http://www.researcherid.com/rid/C-3926-2008>**

Fault Detection in a Continuous Pulp Digester

P. Dufour, S. Bhartiya, T.J. English, E.P. Gatzke,
P.S. Dhurjati and F.J. Doyle III



- Motivation
- Digester Operation and Faults
- Fault Detection Techniques
 - NL dynamic gross error detection
 - Abnormal event detection with ANN
 - Inference of faults with ANN
- Summary



University of Delaware
Process Control and
Monitoring Consortium

Project Overview

- DOE Agenda 2020 Project



Honeywell

Westvaco

ABB



- Objective:

- Develop a model-based approach to sensing, diagnostics, and control of key internal operating parameters of extended delignification digesters (*i.e.*, lignin profile and final Kappa)

- Approach:

- Interface first principles model with DCS system to develop on-line estimator
- Integrate digester parameter estimation with multivariable control and fault handling

- Benefits:

- Improved final Kappa control
- Diagnostic status of fault conditions
- Better understanding of lignin profile

Project Overview (cont'd)

- **Challenge:**
 - Monitor and operate digester during transient operations (grade and rate changes)

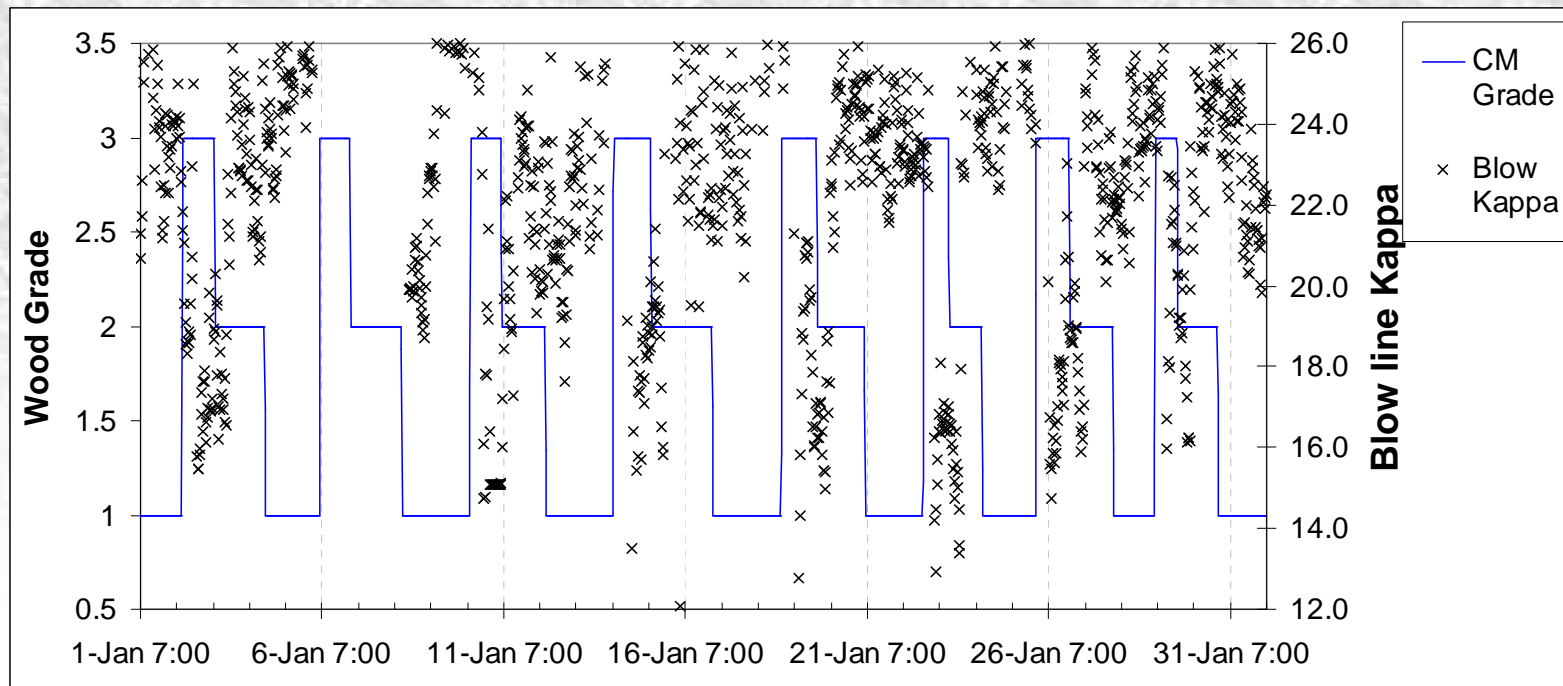

Motivation – Profile Management

- **High levels of dissolved solids has negative impact on pulping efficiency and pulp properties (Lloyd *et al.*, 1998)**
- **Recent studies on effect of EA concentration profile**
 - pulp strength properties (higher EA at end cook \Rightarrow increased tear index & improved bleachability (Kettunen *et al.*, 1997))
 - HW pulping: alkali profile has major impact (6%) on selectivity (yield and viscosity (Achren *et al.*, 1998)) at same kappa level
 - multiple WL additions/BL extractions/CC impregnation (Lo-Solids) \Rightarrow low/even EA profile and 2-5% yield improvement (Marcoccia *et al.*, 1998)

“with an optimized EA profile, pulp yield, strength and bleachability can be increased” (Kettunen *et al.*, 1998)

Digester Flowsheet

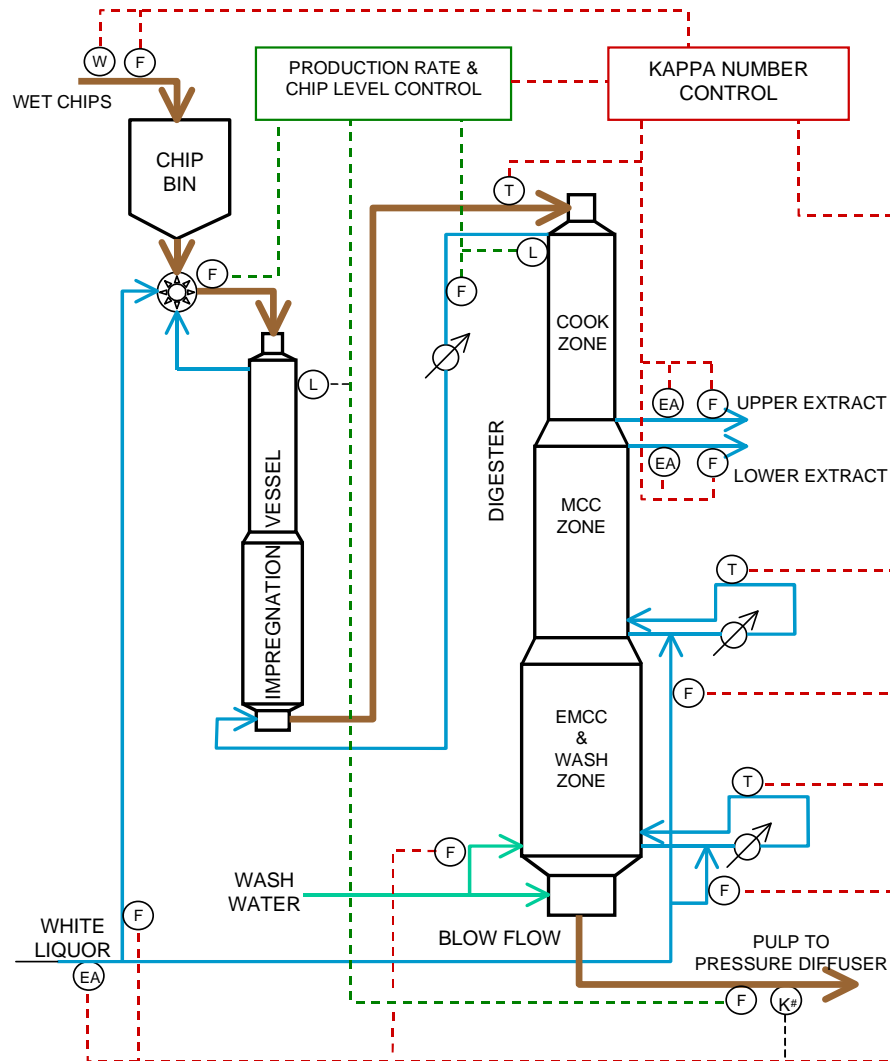

Process Faults in the Digester

- Hardware failures
 - sensors (over 100 - noise, **bias**, drift, failure)
 - actuators (e.g., pumps - inlet, circulation, extract)
 - controllers
- Feedstock variation
 - **chip composition**
 - **moisture**
 - **liquor concentrations**
 - *higher priority*

Feedstock Properties Variation

[Wisniewski and Doyle, JPC 98]

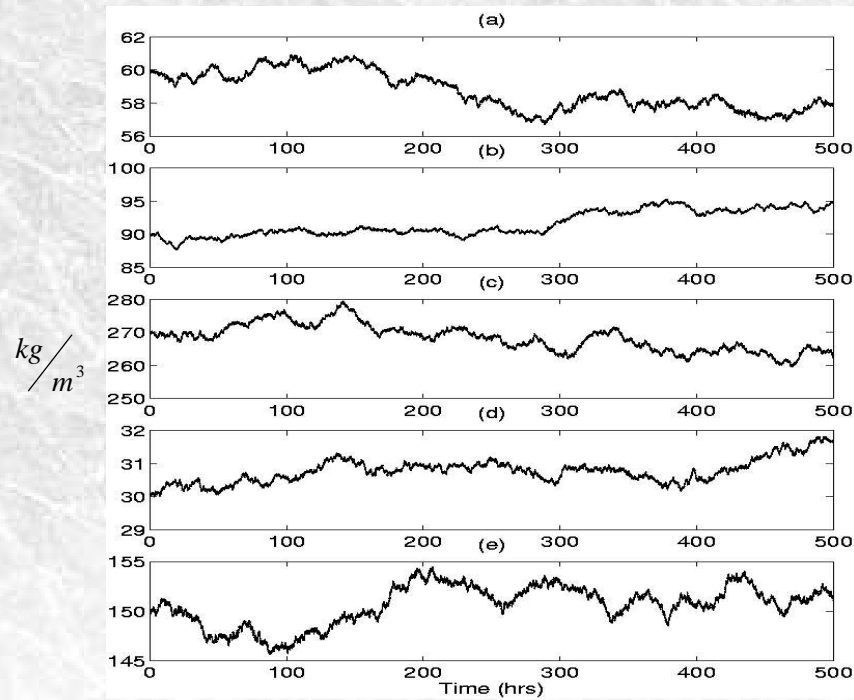

Chips Densities

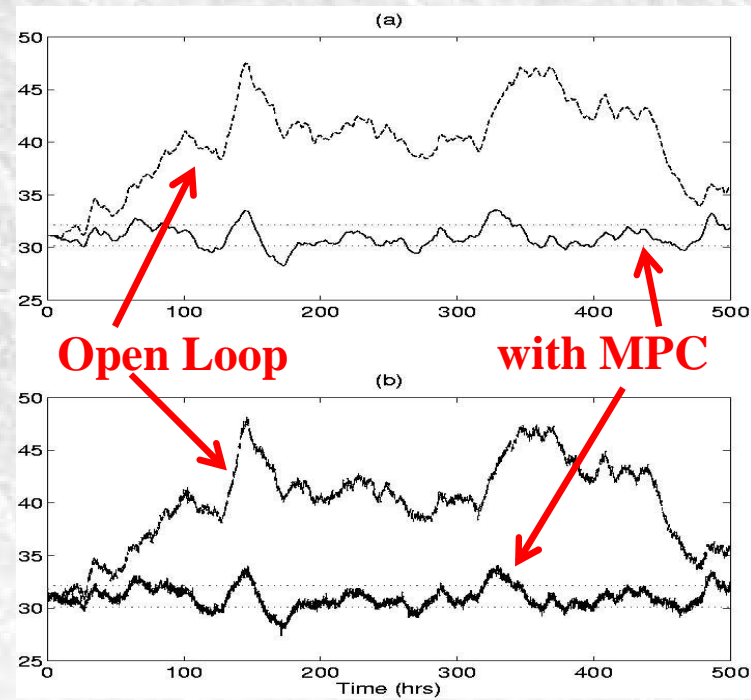

Kappa Number

Classification of Fault Methodologies

People

First Principles



Experiences Based

Model Based

Expert Rules

Residual and Statistic Approach

Fuzzy Rules

Gross Error Detection

Decision Tree

Principal Component Analysis

Moving Horizon Estimation

Qualitative Trend Analysis

Extended Kalman Filter

Neural Network

Parameters Estimation

Observers

Process Fault Diagnosis Approach

- NL Dynamic Gross Error Detection
- Abnormal event detection with ANN
- Inference of faults with ANN

Gross Error Detection

- Approach: evaluate bias b and the real physical value y using model and sensors measurement y_p

$$\min_{y,b} (y_p - b - y)^T Q^{-1} (y_p - b - y)$$

$$s.t : Ay = C$$

Q : noise covariance matrix

A, C : model constraints

- G.E.D. initially developed for linear steady-state (s/s) model [Narasimhan *et al.*, 1987] and extended to nonlinear s/s model [Renganathan *et al.*, 1999]

Nonlinear Dynamic Gross Error Detection

- Introduce the nonlinear dynamic for the model constraints:

$$\min_{y,b} (y_p - b - y)^T Q^{-1} (y_p - b - y)$$
$$s.t.: \begin{cases} \frac{dx}{dt} = f(x,u) \\ y = g(x) \end{cases}$$

- On-line implementation strategy:



Gross Error Detection: Results

Signals : x : real . : measured (with noise and bias) o : determined

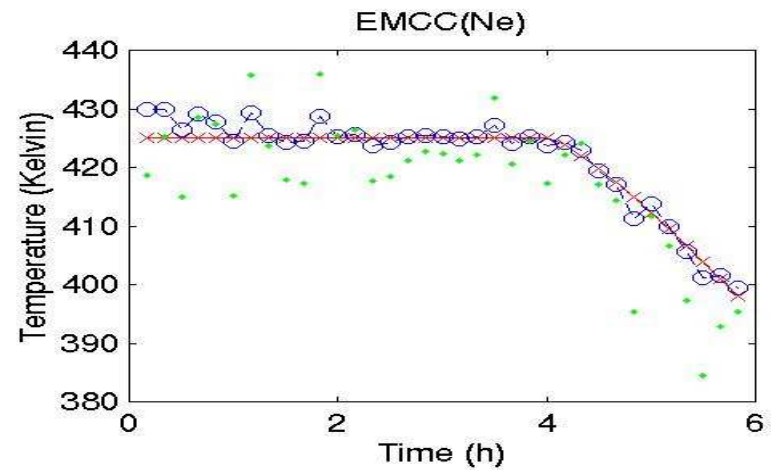
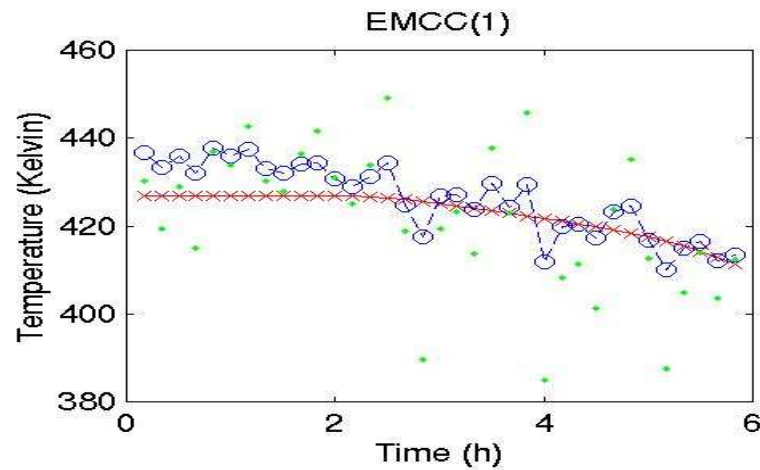
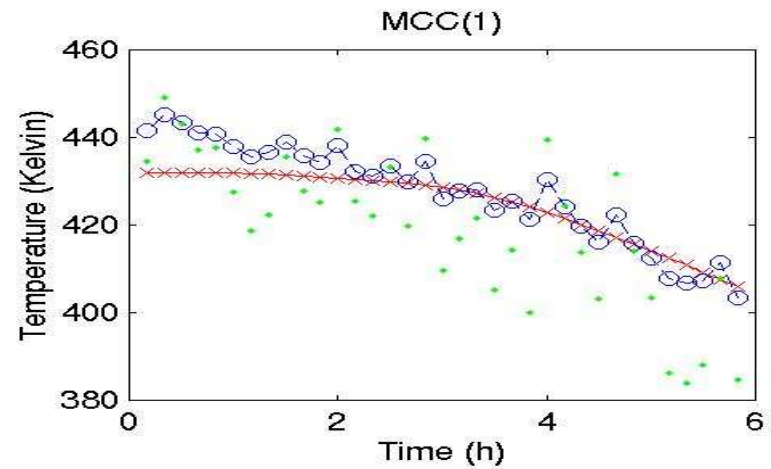
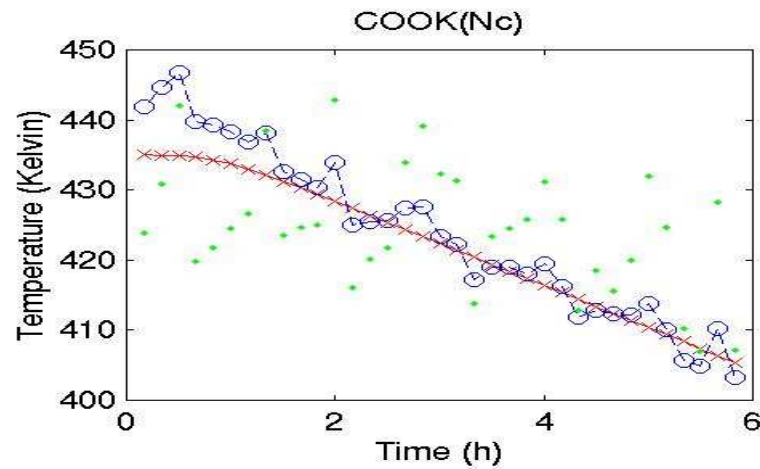

Gross Error Detection: Results

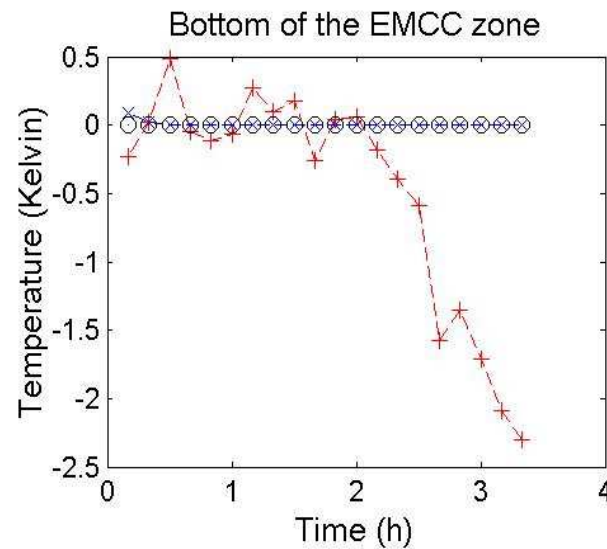
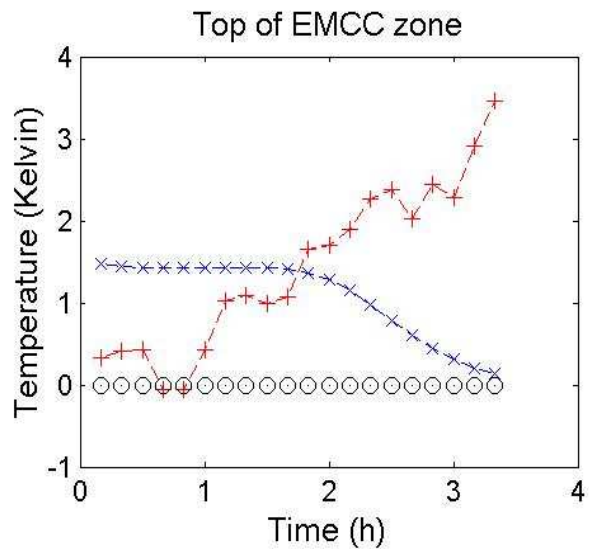
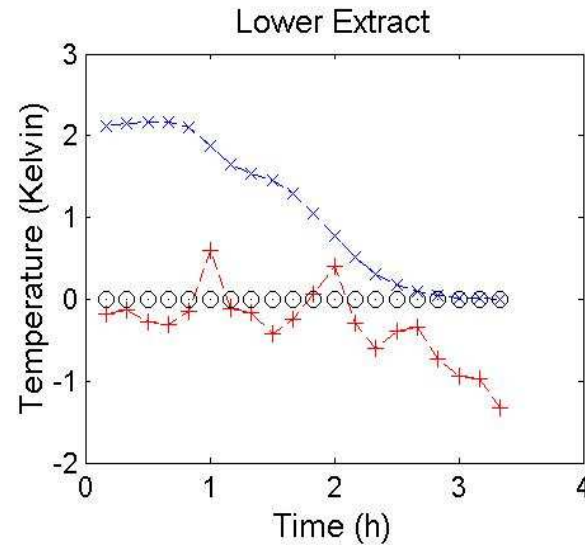
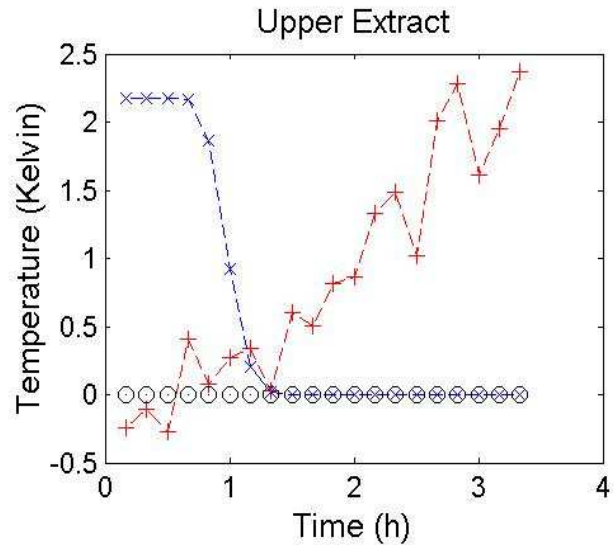

Error:
Target (o)
Measure (+)
Solution (*)

Gross Error Detection: CPU Time

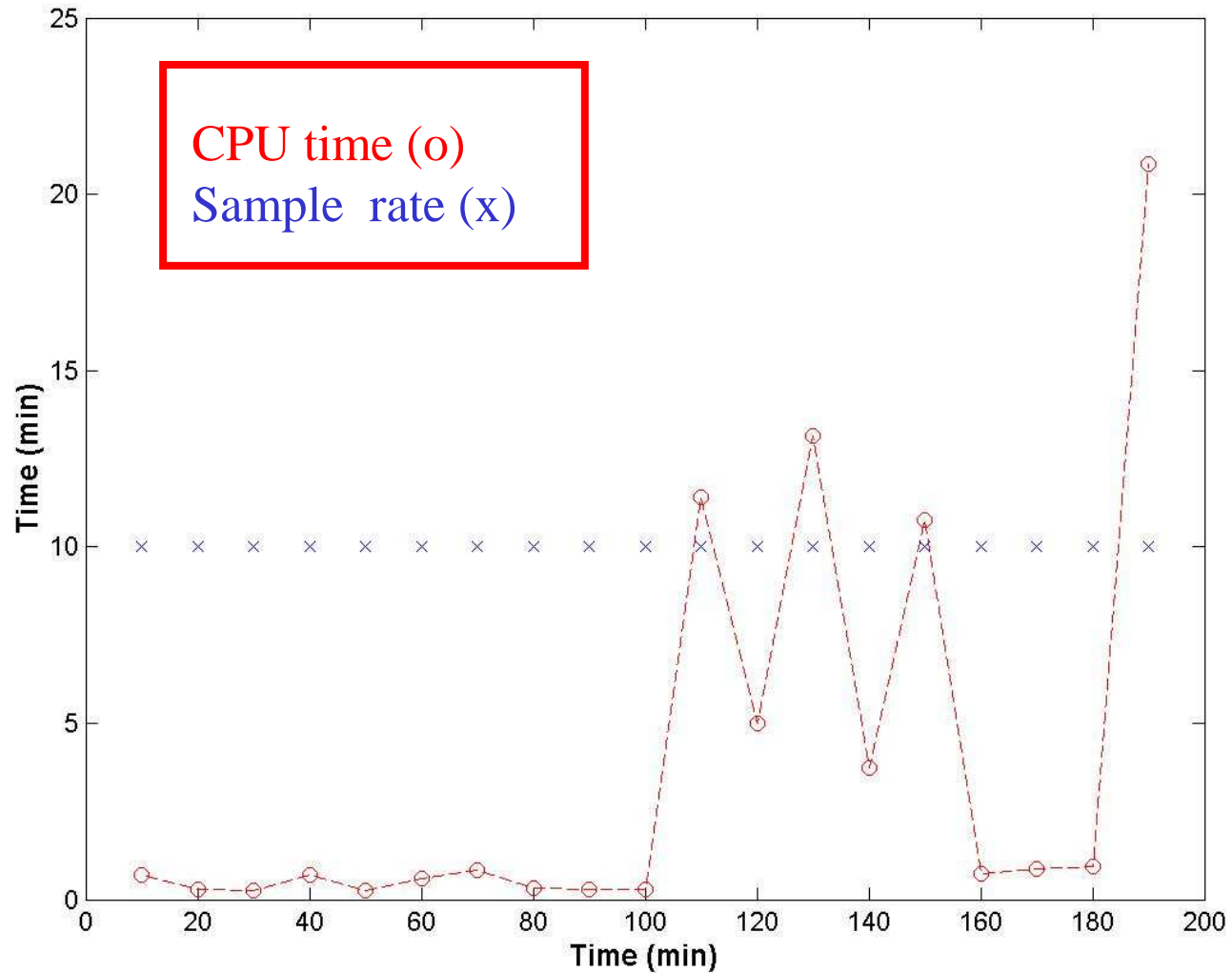

Process Fault Diagnosis Approach

- NL Dynamic Gross Error Detection
- Abnormal event detection with ANN
- Inference of faults with ANN

Kappa # Variation Cause Detection: Neural Network Approach

- Issue: different faults may have similar effect on kappa #:
 - lignin increase
 - moisture content increase
 - liquor density decrease
 - cook temperature decrease
- Proposed solution: train a multi-node neural network to recognize (output =1) the fault (lignin, moisture or liquor)
- No plant data available:
 - Training set generated with first principles model
 - Faults induce a ramp increase in kappa # by 2 on a 24 hours period

Results with Trained Faults (24h ramp)

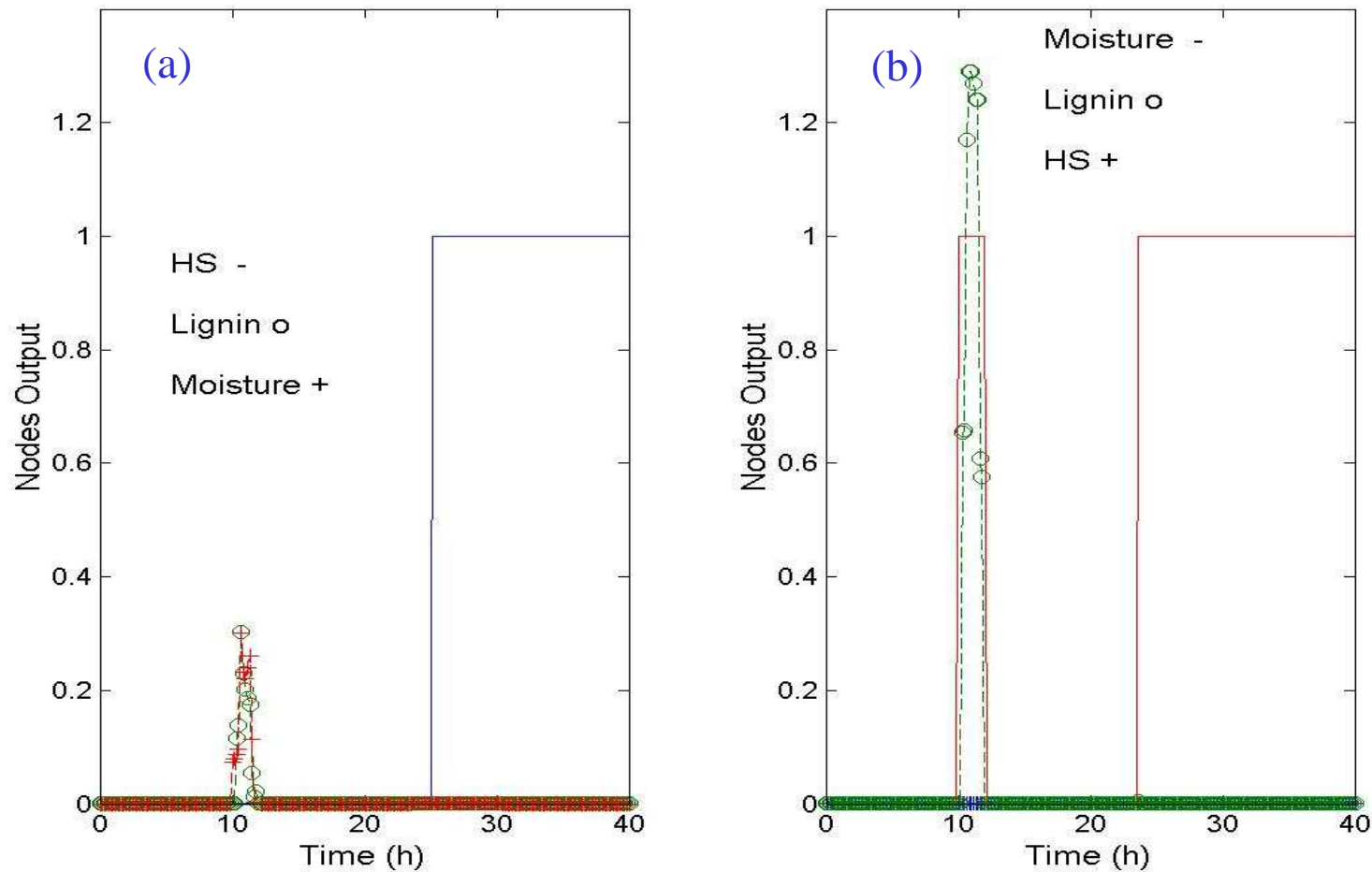

ANN responses for (a) HS variation and (b) moisture variation

Results with Untrained Faults

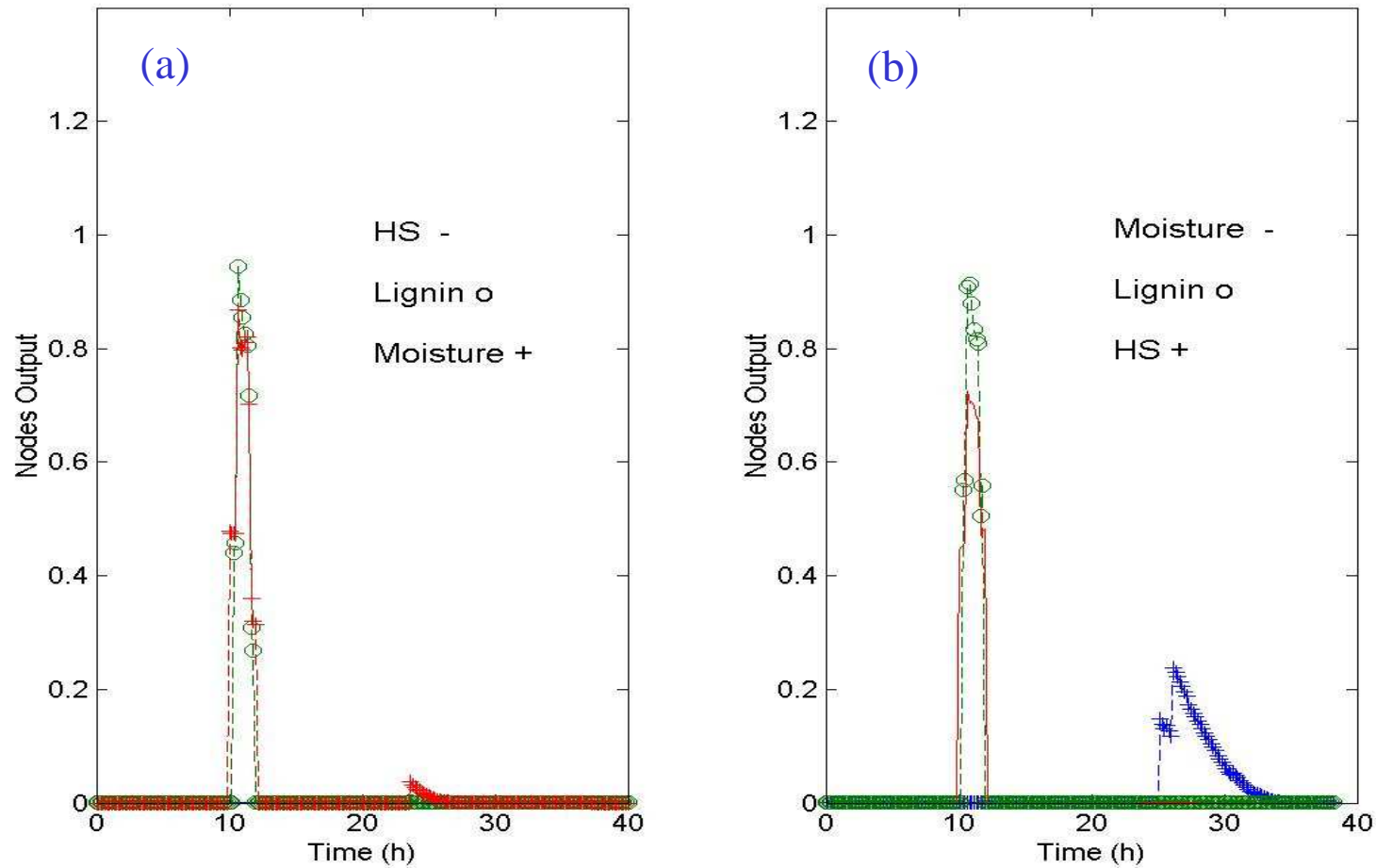

Neural Network responses for (a) cook temperature variation, and (b) HS variation inducing a 21h ramp for the Kappa #

Kappa# Variation Cause Detection: Observations

- Extrapolation: faults that lead to an increase in kappa # by 2 over 24h (training set), 23h and 25h periods are recognized
- Extrapolation: NN is unable to recognize faults which introduce kappa # increase by 2 over 21h
- NN responds correctly to unknown faults
- NN structure influence:
 - 3 nodes (ideal outputs $\in \{0,1\}$): 74% of correct diagnosis
 - 1 node (ideal output $\in \{0,1,2,3\}$): 54% of correct diagnosis

Process Fault Diagnosis Approach

- NL Dynamic Gross Error Detection
- Abnormal event detection with ANN
- Inference of faults with ANN
 - recurrent neural network structure
 - NARMA structure
 - studied training set design

Neural Net vs. Residual Approach

Training

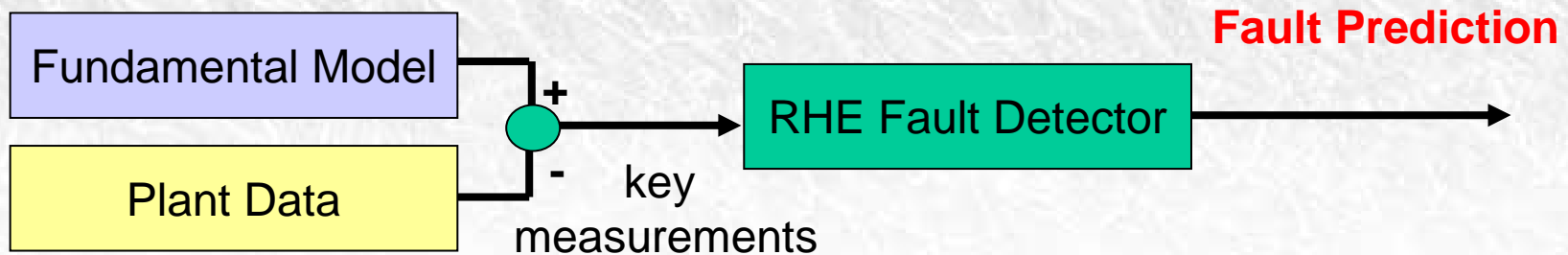
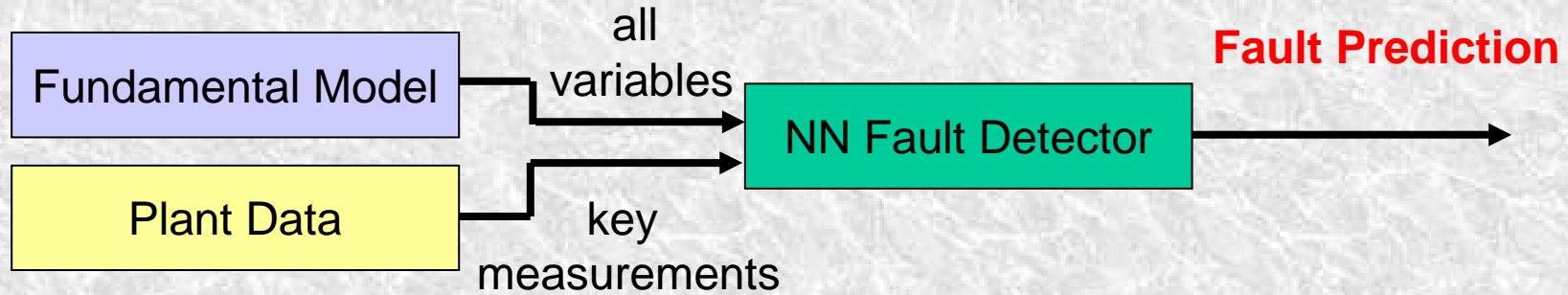

Feedstock Properties Variation Detection: Training Set Design

Step 1: Variations Set Design

- Combination of step changes with 8 possible magnitudes from 92% to 108% around each nominal value for:
 - Moisture content
 - 5 wet chips densities
 - 2 white liquor densities

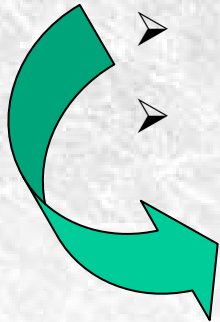

Step 2: Data Generation

- 4096 simulations of the open loop model

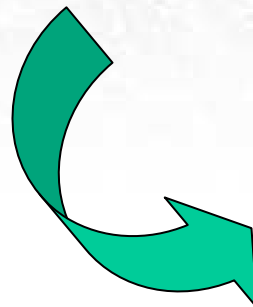

Step 3: Get Training Set

- With measurements set (EA and HS at the upper extraction in the digester)

Results

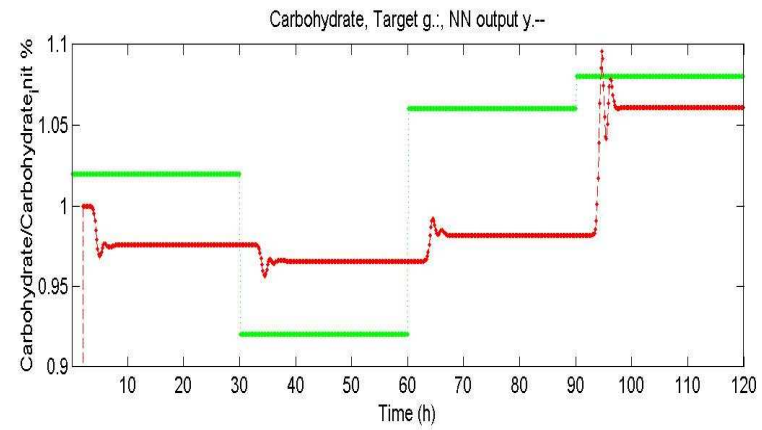
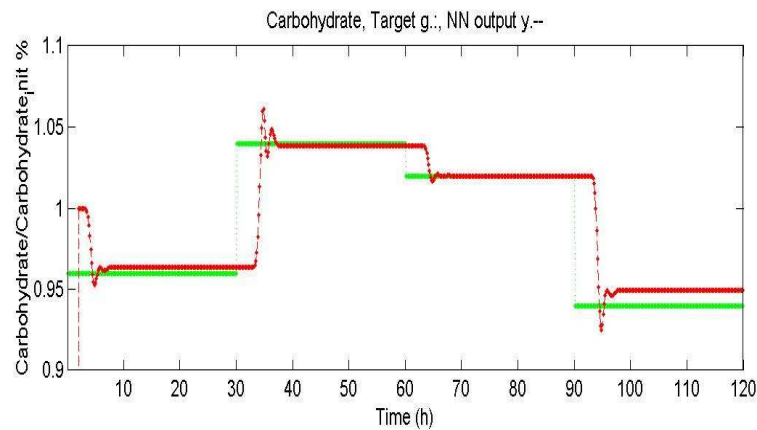
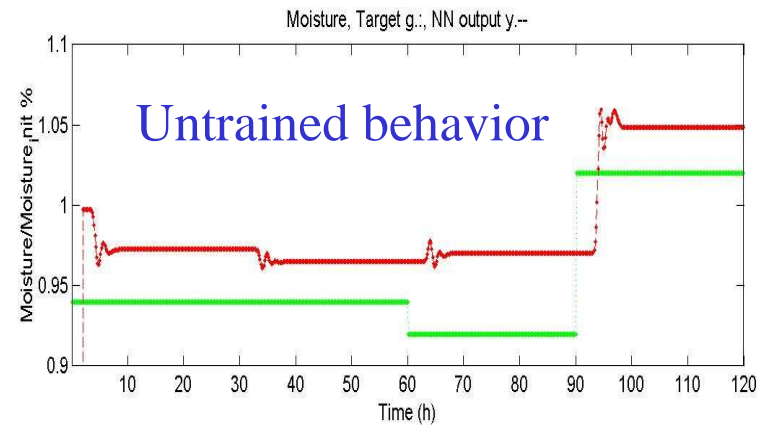
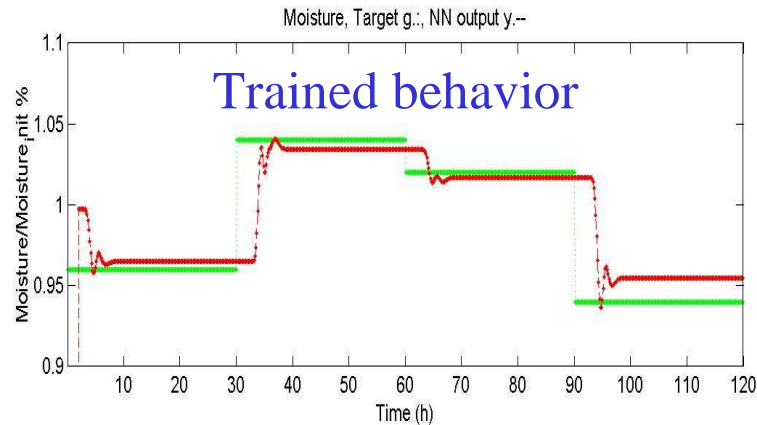

- Observations:

- The neural network does not extrapolate to untrained regions
- Moisture, carbohydrate, arboxylan and HS densities are detectable

New Variation Set Design

- Include the 3 manipulated variables (MV) that affect measurement needed at NN inputs : 2 flow rates and the cook temperature
- Reduce training set size by building a variation set for only each of the 4 detectable properties with the 3 MVs
- One NN is dedicated for each detectable property
- Among all the cases generated in the variations set, 2000 runs are chosen randomly
- Only step variations are used in the training set

Results

Moisture content: normalized variations introduced and neural network response

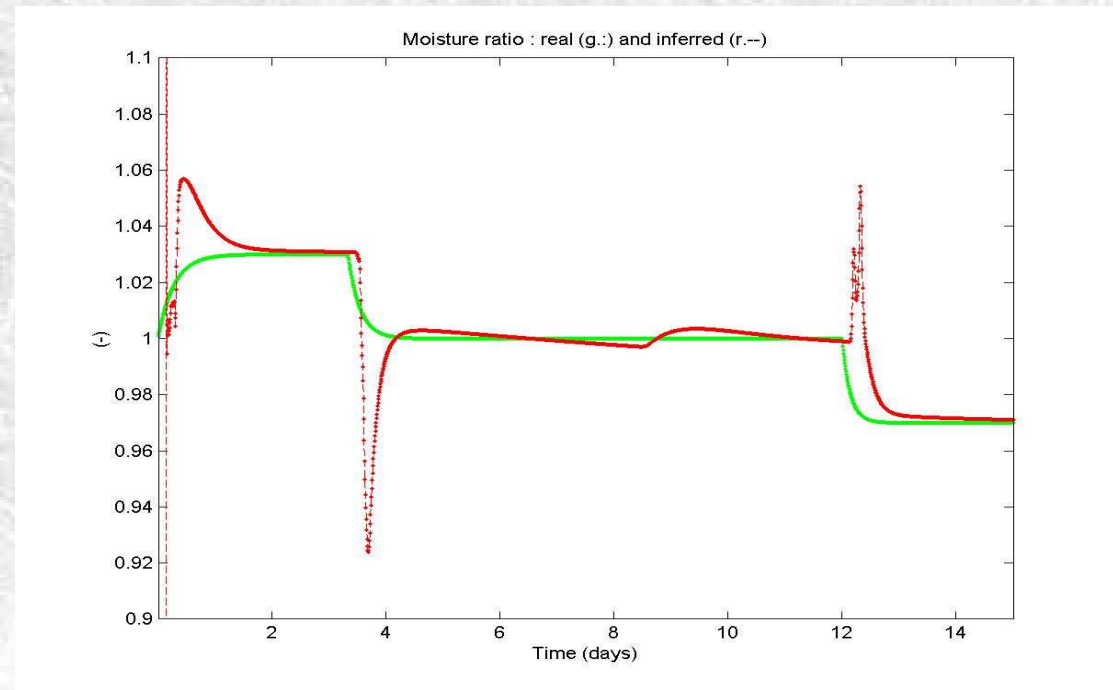
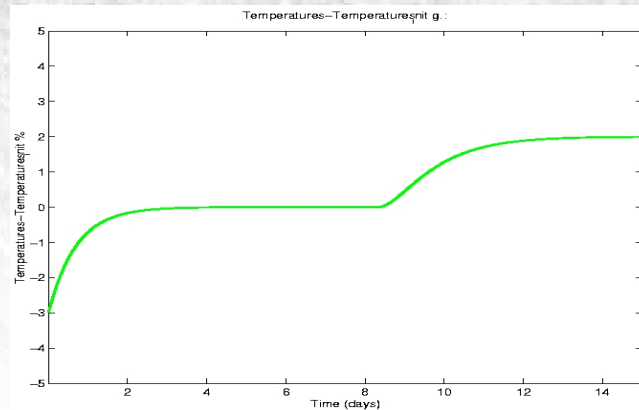
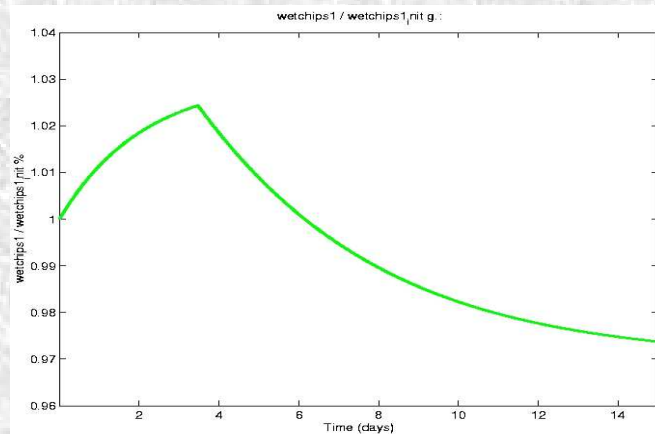

Variations introduced in 2 MVs: white liquor flowrate (top) and cook temperature (bottom)

Good extrapolation to various signals shape not used by the training set

Results

Hydrosulfide density: normalized variations introduced and neural network response

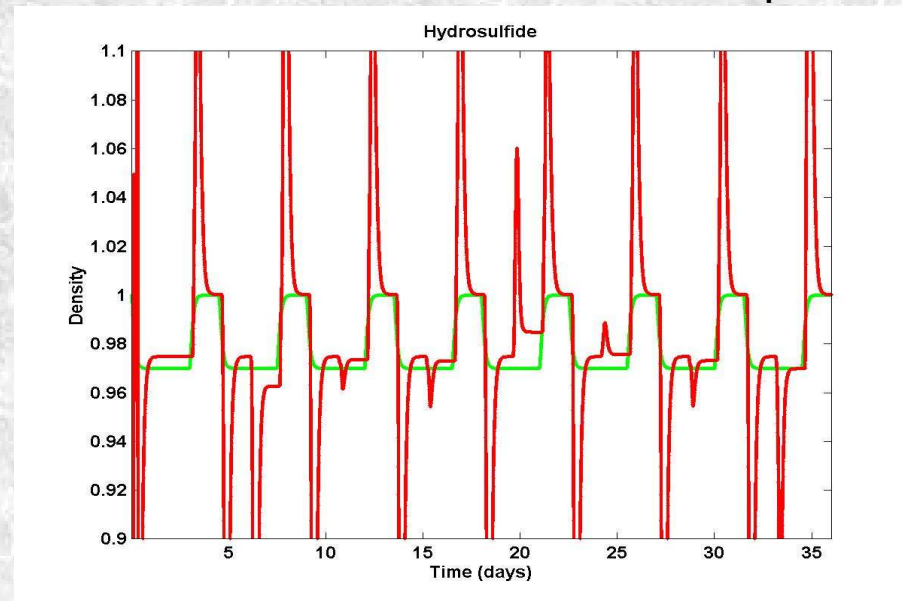
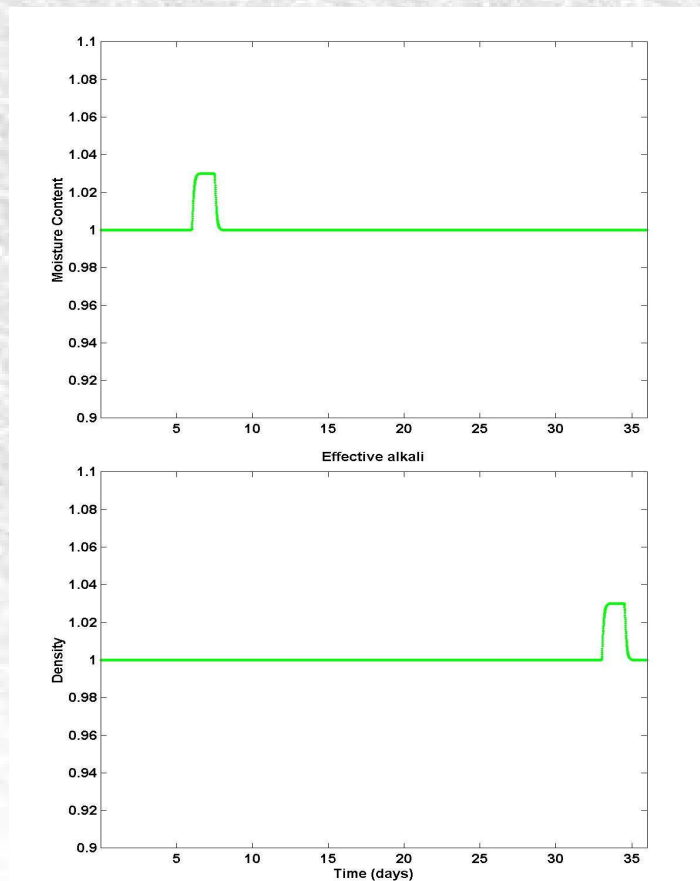

First and last changes introduced in the suite of the 7 remaining properties

- Good diagnostic
- Good extrapolation to signals shape not used by training set
- The 4 NN outputs can be combined to correct the remaining errors

Summary

- Gross error detection for temperature measurements leads to good results but can be limited for on-line implementation
- A neural network based approach allows one to distinguish faults that affect similarly the final kappa #
- A neural network based approach allows the inference of 4 among 8 unmeasured feedstock properties:
 - Variation set design for the model based training set building has been presented
 - Wider ranges of prediction
- Methods are under evaluation on-site at pulp mill



Unmeasured Variations in Feedstock

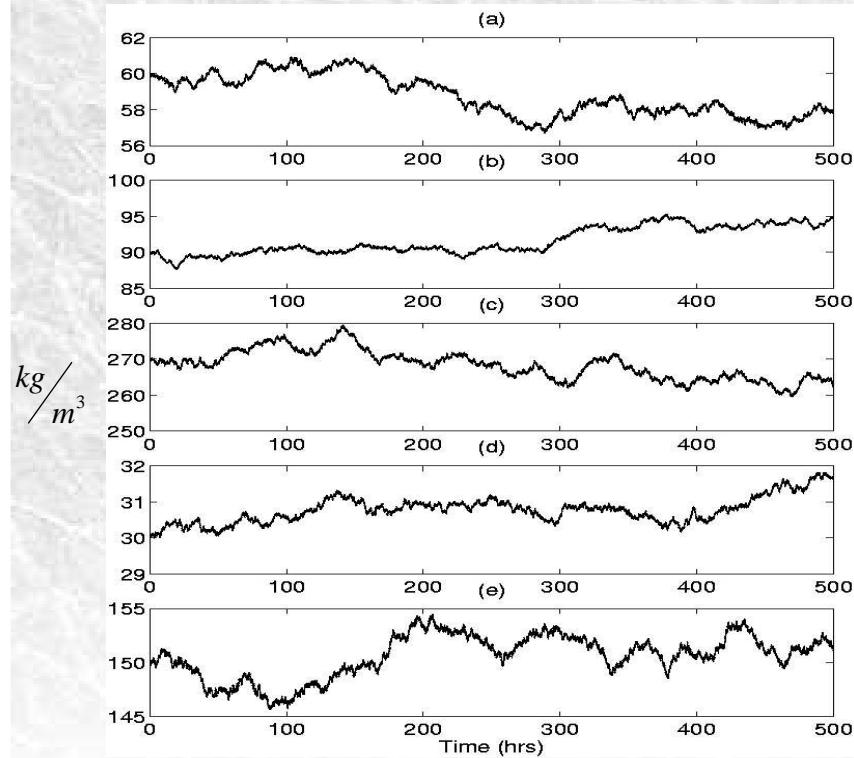

Chips Densities

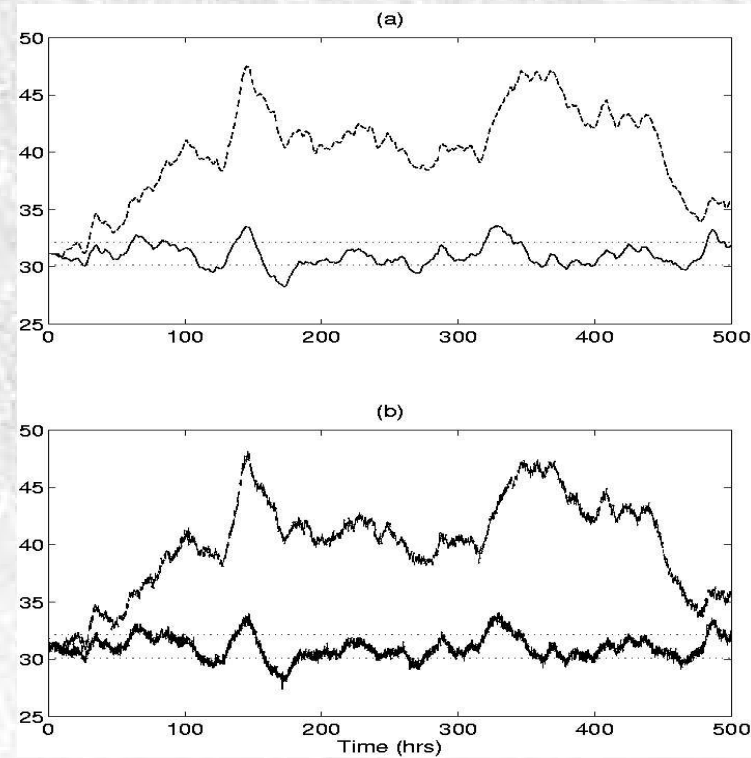

Without
Noise

With
Noise

Kappa Number (open/closed loop)

Neural Network Results

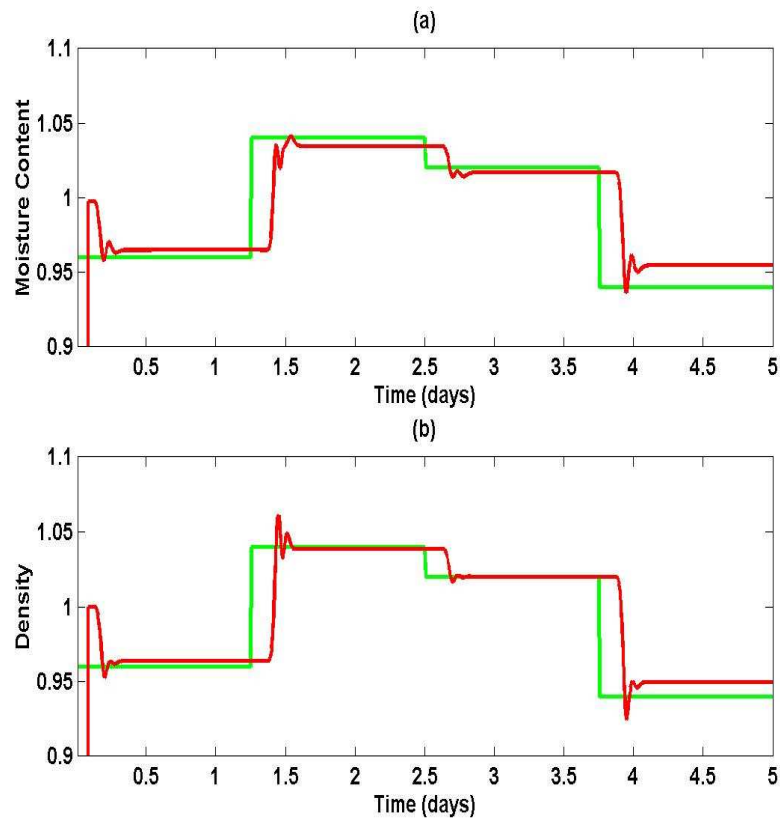

Moisture content (a) and carbohydrate density (b) (normalized variations)

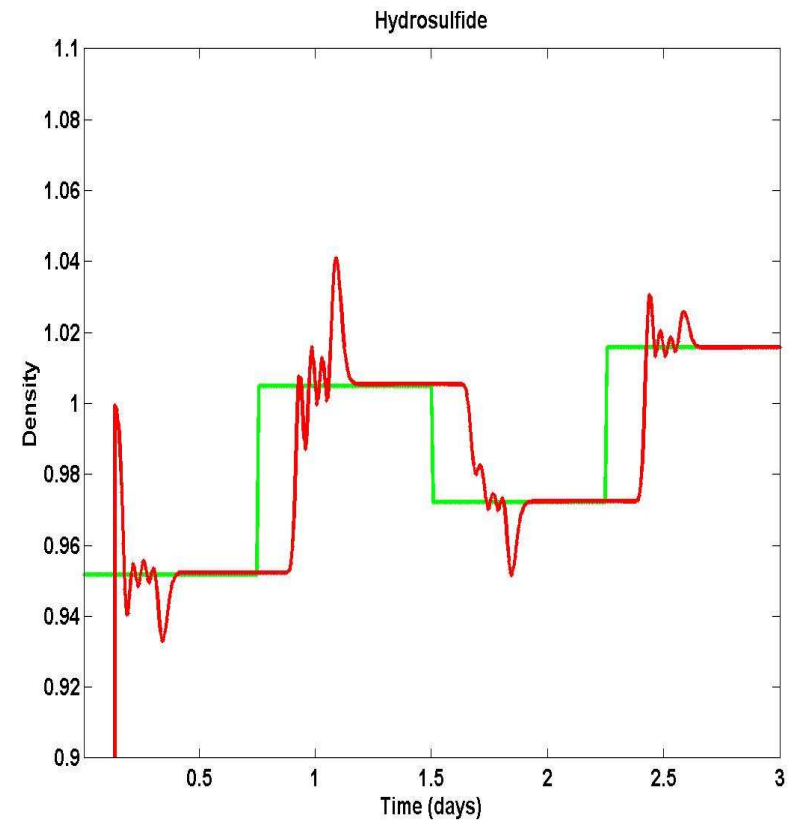

Hydrosulfide density