



HAL
open science

A neural network approach for the diagnosis of the continuous pulp digester

Pascal Dufour, Sharad Bhartiya, Prasad S. Dhurjati, Francis J. Doyle Iii

► **To cite this version:**

Pascal Dufour, Sharad Bhartiya, Prasad S. Dhurjati, Francis J. Doyle Iii. A neural network approach for the diagnosis of the continuous pulp digester. Digester Workshop, Jun 2001, Annapolis, MD, United States. hal-00352521v2

HAL Id: hal-00352521

<https://hal.science/hal-00352521v2>

Submitted on 22 Jan 2009

HAL is a multi-disciplinary open access archive for the deposit and dissemination of scientific research documents, whether they are published or not. The documents may come from teaching and research institutions in France or abroad, or from public or private research centers.

L'archive ouverte pluridisciplinaire **HAL**, est destinée au dépôt et à la diffusion de documents scientifiques de niveau recherche, publiés ou non, émanant des établissements d'enseignement et de recherche français ou étrangers, des laboratoires publics ou privés.

**This document must be cited according to its final version
which was presented as:**

**P. Dufour¹, S. Bhartiya¹, P.S. Dhurjati¹, F.J. Doyle III¹,
"A neural network approach
for the diagnosis of the continuous pulp digester",
Digester Workshop,
Annapolis, MD, USA, june 28, 2001.**

**All open archive documents of Pascal Dufour are available at:
<http://hal.archives-ouvertes.fr/DUFOUR-PASCAL-C-3926-2008>**

**The professional web page (Fr/En) of Pascal Dufour is:
<http://www.lagep.univ-lyon1.fr/signatures/dufour.pascal>**

1

University of Delaware,
Department of Chemical Engineering,
Newark, DE 19716, USA
<http://www.udel.edu>

A NEURAL NETWORK APPROACH FOR DIAGNOSIS IN A CONTINUOUS PULP DIGESTER

P. Dufour, S. Bhartiya, P.S. Dhurjati
and F.J. Doyle III ¹

*Department of Chemical Engineering,
University of Delaware,
Newark, DE 19716*

Abstract:

A strategy for detection of feedstock variations in a continuous pulp digester is presented. A Gaussian Radial Basis Function Neural Network is used to infer these unmeasured variations. The absence of plant data motivates the development of training set data. The efficiency and limitation of the approach is demonstrated with a first principles model.

Keywords:

Pulp Digester, Neural Network, Fundamental Model, Fault Detection.

1. INTRODUCTION

The pulp and paper industry forms a large and important sector of the Chemical Process Industry and is highly capital intensive. For the period 1996-1998, planned capital investments and new facilities to existing facilities were evaluated to exceed \$10 billion. Therefore, demand for higher safety and reliability has increased. Process diagnosis has gained considerable academic and industrial interest and numerous approaches have been proposed. Industrial control systems in this sector have become more complex, and advanced control systems like MPC require the presence of experts to diagnose the cause of performance degradation and to retune if needed.

The goal of our work is to develop and demonstrate computational modeling and control methodologies that will facilitate integration of control and fault diagnosis methodologies for a continuous pulp digester. This paper is focused on a methodology and preliminary simulation results for Fault

Detection and Isolation (FDI) as applied to this process.

The paper is organized as follows: the definition of the problem and the motivation for use of neural network is described. Then, the first principles model is briefly described. Next, the design of the variation set needed to create the training set of the neural network is discussed. Finally, efficiency, limitations and robustness for the use of each neural network designed are demonstrated on a first principle model.

2. FAULT SET DEFINITION

Continuous digesters (figure 1) are large vertical tubular reactors. White liquor (aqueous solution of effective alkali and hydrosulfide) strips the presteamed porous wood chips of lignin, freeing the wood fibers. The main reaction takes place in the upper section of the digester referred to as the cook zone. In this section, both the chips and liquor flow cocurrently. At the end of the cook zone, spent liquor is extracted for chemical recovery. The chips, however, continue

¹ Corresponding author: Fax (302) 831 1048, Phone (302) 831 0760, fdoyle@udel.edu

their downward flow in the modified continuous cooking (MCC) zone and extended modified continuous cooking (EMCC) zone where they encounter weak liquor flowing countercurrently. The wood pulp is finally extracted at the outlet of the EMCC. One of the main control issues is concerned with the quality of the pulp, i.e., the kappa number.

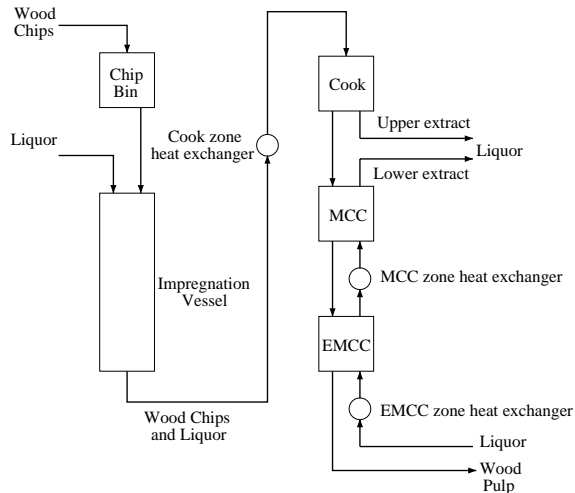

Fig. 1. Schematic of a chemical pulp digester.

Based on a mill survey, it was concluded that faults with sensors and the actuators do not cause a serious problem with the kappa number control. Instead, the most common problem arises in uncertainty about the process behavior that can affect the closed-loop control results. In the digester, these uncertainties deal with:

- The moisture content of the wood chips fed to the chip bin. Only one measurement of moisture content is available per day. This value is currently used to manually tune the flowrate of the recovered white liquor at the inlet of the impregnation vessel.

Moreover, certain properties can not be measured:

- The 5 woodchips densities used in the first principles model:
 - high reactivity lignin,
 - low reactivity lignin,
 - carbohydrate,
 - galactoglucomman,
 - araboxyylan.
- The density of the 2 recovered white liquor species mixed with the chip in the impregnation vessel:
 - effective alkali (EA),
 - hydrosulfide (HS).

It has been previously pointed out (Wisniewski *et al.*, 1998) that stochastic variations of the feedstock (figure 2 for the wood species densities) has an impact on the final kappa number at the outlet of the digester (figure 3). There is,

therefore, a need to ascertain these stochastic variations and take appropriate action.

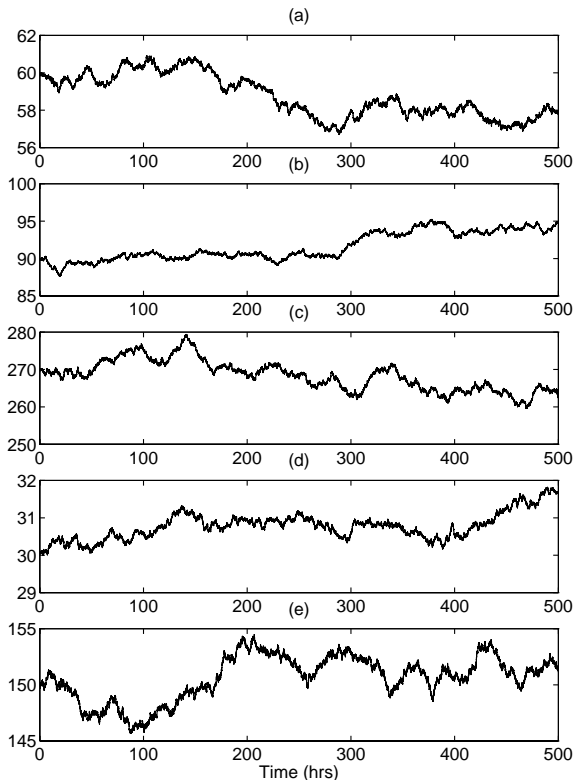

Fig. 2. Stochastic wood densities compositions (kg/m^3): (a) high reactivity lignin, (b) low reactivity lignin, (c) carbohydrate, (d) araboxyylan, (e) galactoglucomman.

3. NEURAL NETWORK APPROACH

Neural networks have been used for over 15 years for modeling, control, as well as for fault diagnosis. Indeed, they have very useful properties, such as their ability to handle nonlinear behaviors and tolerance to noise. Among the recent studies based on neural networks, (Lin *et al.*, 2000) combined a neural network with PCA to diagnose faults in the Eastman benchmark problem. The generation of training data to build the neural network is discussed by (Rengaswamy *et al.*, 2000). Another application combines a neural network and a fuzzy system to improve the diagnosis time and monitor qualitative feedstock variations detection in a chemical plant (Ruiz *et al.*, 2001). Here, a method to infer the unmeasurable magnitude of the eight faults described above using available measurements and a neural network approach is described.

A first principles model is used to create the training set as well as for evaluation of each neural network. The use of an accurate model is crucial in this case, since seven of these eight

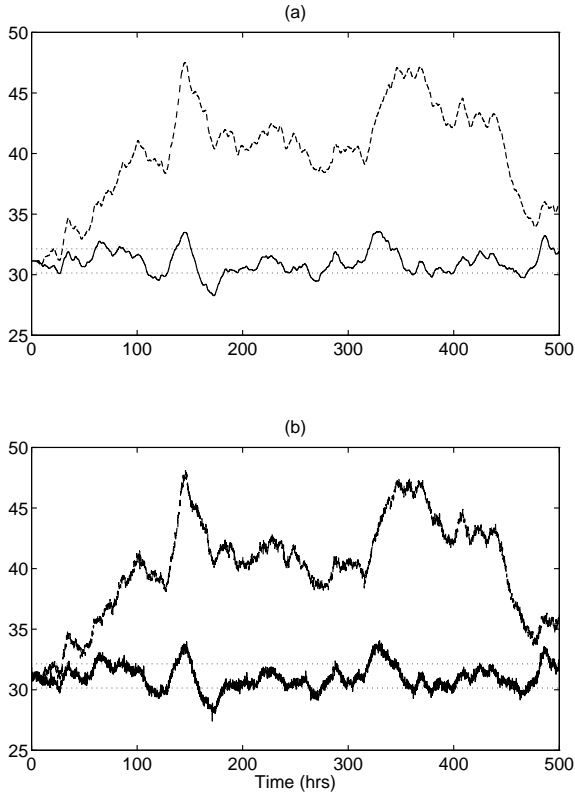

Fig. 3. Kappa number in open loop (dashed) and with MPC (solid): (a) without and with (b) measurement noise.

feedstock qualities descriptors are not available and therefore their effects can not be quantified.

4. CONTINUOUS PULP DIGESTER MODEL

For modeling purposes, the digester is approximated as a series of 150 continuous stirred tank reactors. The first principles model consists of mass balances for the non-porous solid and the free liquor components as well as balances between the 2 phases within each reactor. For modeling assumptions and a description of the conservation laws, the reader is referred to (Wisniewski *et al.*, 1997). Based on this model, a code using Matlab has been developed (Doyle *et al.*, 1999) and is adopted to simulate the process and the model in the approach developed in this paper.

A sensitivity analysis shows that, among all the sensors actually available, the EA and HS measurements of the liquor at the upper extract of the digester are the most useful to detect the causes of the changes in the kappa number. They will both be used to infer the eight unknown fault magnitudes in the neural network strategy.

The first step in the construction of a neural network deals with availability of data needed to form the training set. As discussed previously, no plant data can be used since seven of these eight plant variables are not measured. Therefore,

the training set can only be created by simulations based on the first principles model. The underlying problem is to choose the nature and the amount of simulations needed to create the training set.

5. A SIMPLE TRAINING SET DESIGN

In this initial attempt, faults were introduced in the simulation as a combination of step functions for each of the unknowns. In order to avoid the computation of an excessive amount of simulations², the magnitude of the variations (referred to as the variation set) was designed as follow:

- each of the n_u magnitude can take n_v values different from the nominal value (i.e 100%),
- when more than one fault occurs, all their magnitude are the same.

Therefore, with $n_v = 8$, $2^{n_v} \times n_u = 2^8 \times 8 = 2048$ simulations need to be computed. Each case is simulated for a 12h duration for the process. This duration is sufficient enough such that the EA and the HS density measurements of the liquid located at the upper extract can be affected by these faults. The magnitudes range between 92% and 108% with a step of 2%.

The choice of the neural network structure to represent the dynamic model is also important (Henrique *et al.*, 2000). In the present work, a NARMA model is used (Su *et al.*, 1992).

The neural network is effective in predicting the moisture content (Figure 4a), the carbohydrate density (Figure 4b) and also, to a certain extent, the araboxylan density and the HS density can be inferred. Indeed, in most of the cases, after transient due to faults decay, the tracking of the magnitudes introduced is effective.

However, testing the neural network in regions outside the training/test data (here with uncorrelated variations for each of the eight faults) shows its limitations: the results are very poor and the neural network is not able to estimate correctly the fault magnitudes (Figure 5). This underlines the classical drawback of poor extrapolation possibilities for a neural network. But this poor result is also partially due to the current training set that does not cover a sufficiently representative space for the different process behaviors. Its design remains therefore open.

² Actually, with a 800 MHz PC, 3000 simulations that each simulates 12 hours for the process can be performed in a day using IETek model v1.0 and Matlab.

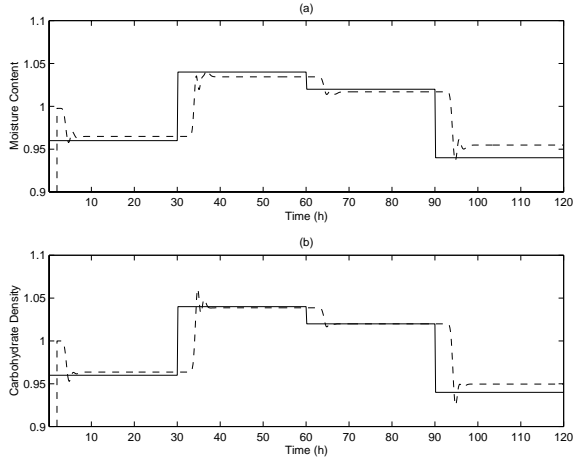

Fig. 4. Moisture content (a) and Carbohydrate density (b): normalized variations introduced (solid) and neural network response (dashed) in trained conditions.

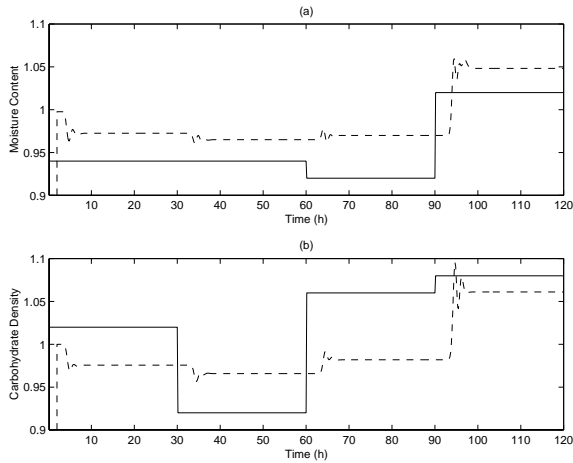

Fig. 5. Moisture content (a) and Carbohydrate density (b): normalized variations introduced (solid) and neural network response (dashed) in untrained conditions.

6. A REDUCED VARIATION SET

In the above work, the large dimension of input space caused the data set to be large despite poor resolution (2% changes). In this section, with higher resolution, a new variation set is built. Therefore, it is now possible to build a more accurate variation set defined only by the faults in the moisture content, the high reactivity lignin and the HS densities. It is constructed as follow:

- each of the magnitude can take 13 different values about their nominal value,
- when more than one of the faults occur, any combination for their magnitude is possible.

Therefore, $n_v^{n_u} = 13^3 = 2197$ simulations have to be computed to build the training set. Each magnitude can take any value between 94% and 106% with a step of 1%. The use of this neural network gives good results in trained situations,

even if transients exist. The performance outside training region is now discussed.

A first run shows the interpolation property of the neural network. The variation set is defined as the same interval [94%, 106%] used for training but with a discrete step decreased of 0.02%. It is seen (Figure 6 for the HS density) that good results are obtained: the transient errors are still present due to the abrupt changes in the faults variations but the static errors almost are quiet small.

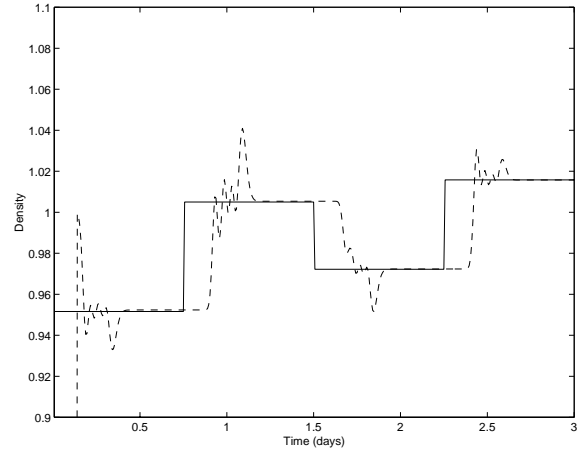

Fig. 6. HS density: normalized variations introduced (solid) and neural network response (dashed) in untrained conditions.

In a second run, any variation in the interval [94%, 106%] with a discrete step of 1% is extended to the 8 initial faults. Even if the initial neural network showed that 4 of them were not detectable, they still have an impact on these neural network errors (Figure 7 for the HS density): static errors are introduced and the neural network fails to give an accurate response.

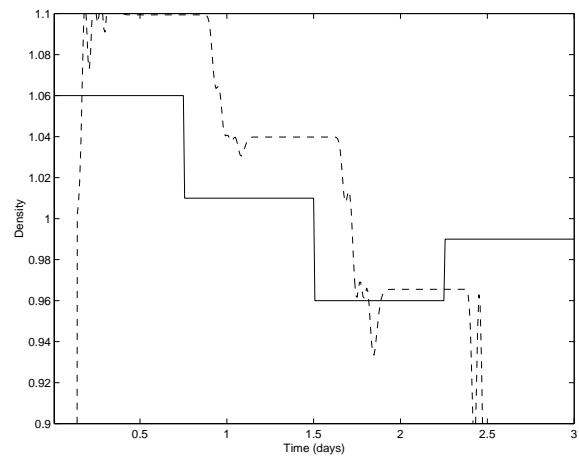

Fig. 7. HS density: normalized variations introduced (solid) and neural network response (dashed) in untrained conditions.

Moreover, since the measurements fed to the neural network are sensitive with respect to

three candidate manipulate variables (MV) of the control loops, their influence must also be studied. These are:

- the chips flowrate in the digester,
- the liquor flow rate at the upper extract,
- the cook temperature.

Simulation shows that the neural network responses are affected by these MV variations: a constant offset error is introduced like depicted Figure 8 for the HS density neural network response to an increase from 100% to 103% in the upper extract flowrate.

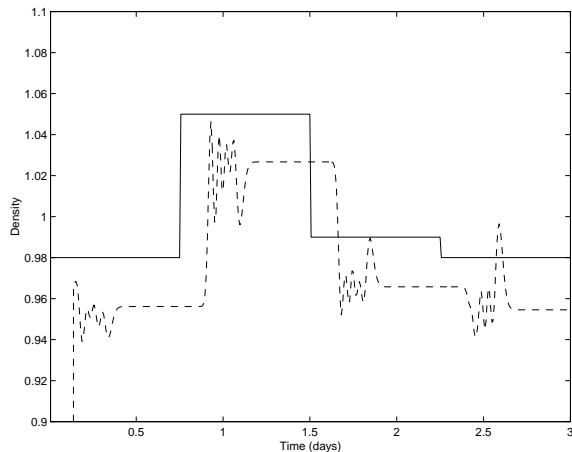

Fig. 8. HS density: normalized variations introduced (solid) and neural network response (dashed) in untrained conditions.

Finally, the design of the variation set for this second neural network shows that a sufficiently discretized variation set can lead to a good interpolation results for untrained situations. Taking account of only the most detectable faults in the definition of the variation set leads to a non-robust neural network with respect to the others faults and also to the manipulated variables.

7. ROBUST VARIATION SET

A third variation set design is now described for the fault detection in the moisture content, carbohydrate, araboxytan and HS densities. For each of these 4 faults, a variation set is constructed including the relevant variable and the 3 MVs introduced previously. In order to minimize the time required for the calculation of the training set, the magnitude of each the 4 faults is allowed to take 9 different values rather than 13 in the previous case. Therefore, $9^4 = 6561$ different simulations where faults are still introduced as step functions have to be performed. Due to the amount of data and to avoid computational issues, 2000 of them are chosen randomly to create the training set.

As expected, the neural network performs well during generalization. The extension to untrained regions, where the MV changes have now a first order shape (Figure 9) rather than a step shape like in the training set, leads to interesting results for the moisture content (Figure 10). Transients exist but the final tracking of the variation is effective.

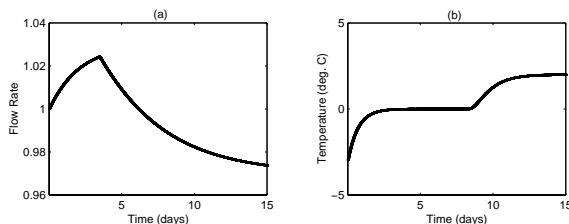

Fig. 9. Faults introduced: (a) normalized chips flow rate, (b) cook temperature deviation.

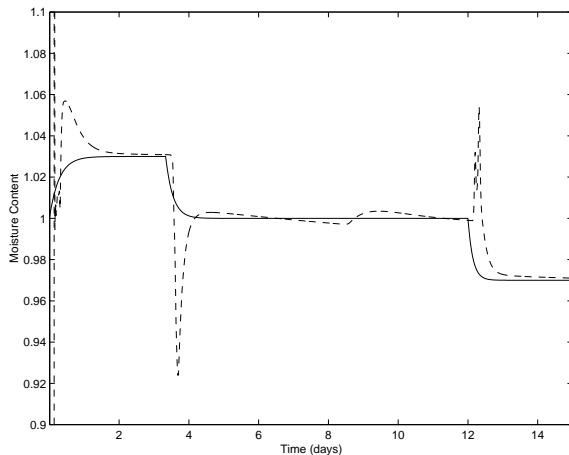

Fig. 10. Moisture: normalized variations introduced (solid) and neural network response (dashed).

As in the evaluation of the performance of the previous neural network, a simulation in another untrained region allows an evaluation of the robustness of the neural network prediction. A suite of faults for each of the seven others variables are introduced (starting from the moisture content figure 11a to the EA density figure 11b and following the order of the list given previously). It is seen that the neural network rejects these disturbances (figure 12), except for the moisture content (the first fault), the carbohydrate density (the fourth change) and the EA density (the last fault). Since both of these variables can be inferred using other neural network, these results could be combined to correct these errors. Otherwise, after transients due to the introduction of each fault, the normal value is nearly reached again. The structure has therefore a natural robustness property.

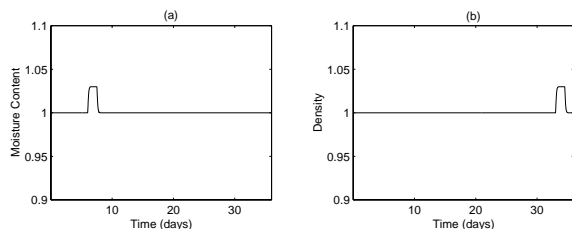

Fig. 11. First (a) and last (b) faults introduced in the suite.

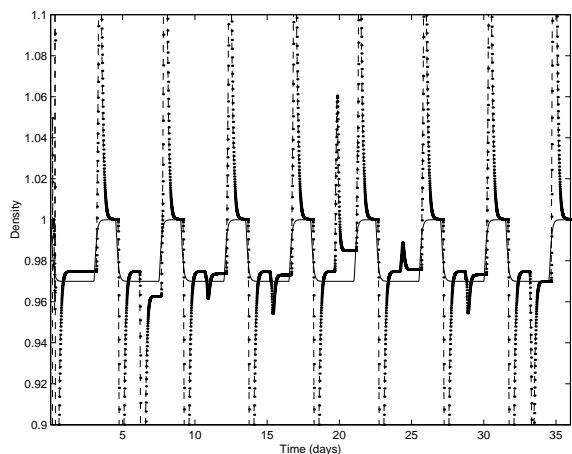

Fig. 12. HS: normalized variations introduced (solid) and neural network response (dashed).

8. CONCLUSION

An approach for the evaluation of the magnitude in the variations of the feedstock properties has been discussed. Based on a first principles model, a neural network approach has been used. Since no plant measurements are available for the necessary training sequence, the issue of designing the variation set has been discussed. It has been shown that 4 training sets based on the candidate MV variations and the relevant variable can be used to build 4 similar neural networks. Among 8 initial unmeasured feedstock properties, one can estimate the magnitude of the moisture content, the carbohydrate density and also to a certain extent, the arboxylan density and the HS density. Future developments are concerned with improvement of the actual robustness by feeding the current responses in a cascaded neural network. It also needs to be evaluated with more stochastic signals as in a closed loop structure. A comparison with a Moving Horizon Estimation strategy is also under investigation (Gatzke *et al.*, 2001).

9. ACKNOWLEDGMENTS

The authors acknowledge funding from the Departement Of Energy (Grant DE-FC07-00ID-13882).

10. REFERENCES

- Doyle III F.J. and Kayihan F. (1999). Reaction Profile Control of the Continuous Pulp Digester. *Chemical Eng. Science* Vol. 54, pp. 2679–2688
- Gatze E.P and Doyle III F.J. (2001). Use of Multiples Models and Qualitative Constraints for on-line Moving Horizon Disturbance Estimation and Fault Diagnosis. *J. Process Control*, in press 2001
- Henrique H.M., Lima E.L. and Seborg D.E (2000). Model Structure Determination in Neural Network Models. *Chem. Eng. Sci.* Vol. 55, pp. 5457–5469
- Lin W., Qian Y. and Li X. (2000). Nonlinear Dynamic Principal Component Analysis for On-line Process Monitoring and Diagnosis. *Compt. & Chem. Eng.* Vol. 24, pp. 423–429
- Rengaswamy R. and Venkatasubramanian V. (2000). A Fast Training Neural Network and its Updation for Incipient Fault Detection and Diagnosis. *Comp. & Chem. Eng.* Vol. 24, pp. 431–437
- Ruiz D., Nougues J.M and Puigjaner L. (2001). Fault Diagnosis Support System for Complex Chemical Plants. *Comp. & Chem. Eng.* Vol. 25, pp 151–160
- Su H., Mc Avoy T.J. and Werbos P. (1992). Long-term Predictions of Chemical Processes using Recurrent Neural Networks: a Parallel Training approach. *Industrial and Engineering Chemistry Research* Vol. 31, pp. 1338–1352
- Wisniewski P.A., Doyle III F.J. and Kayihan F. (1997). Fundamental Continuous Pulp Digester Model for Simulation and control. *AIChE J.* Vol. 43, pp. 3175–3192
- Wisniewski P.A. and Doyle III F.J. (1998). Control Structure and Model Predictive Control of the Weyerhaeuser Digester Problem. *J. Proc. Control* Vol. 8, pp. 487–495