



**HAL**  
open science

## On the importance of the MIMO channel correlation in underground railway tunnels

Yann Cocheril, Marion Berbineau, Pierre Combeau, Yannis Pousset

► **To cite this version:**

Yann Cocheril, Marion Berbineau, Pierre Combeau, Yannis Pousset. On the importance of the MIMO channel correlation in underground railway tunnels. 2nd International Conference on Wireless Communications in Underground and Confined Areas (ICWCUCA), Aug 2008, Val d'Or, Canada. hal-00349153

**HAL Id: hal-00349153**

**<https://hal.science/hal-00349153>**

Submitted on 1 Mar 2021

**HAL** is a multi-disciplinary open access archive for the deposit and dissemination of scientific research documents, whether they are published or not. The documents may come from teaching and research institutions in France or abroad, or from public or private research centers.

L'archive ouverte pluridisciplinaire **HAL**, est destinée au dépôt et à la diffusion de documents scientifiques de niveau recherche, publiés ou non, émanant des établissements d'enseignement et de recherche français ou étrangers, des laboratoires publics ou privés.

# ON THE IMPORTANCE OF AN ACCURATE MIMO CHANNEL MODELING IN UNDERGROUND TUNNELS

*Y. Cocheril<sup>\*</sup>, M. Berbineau<sup>\*</sup>, P. Combeau<sup>#</sup>, Y. Pousset<sup>#</sup>*

<sup>\*</sup>INRETS-LEOST

*20 rue Elisée Reclus – BP 317 – 59666 Villeneuve d'Ascq Cedex – France*

<sup>#</sup>XLIM/SIC

*Bvd Marie et Pierre Curie, BP 30179 – 86962 Futuroscope Chasseneuil Cedex – France*

*Email: yann.cocheril@inrets.fr*

## ABSTRACT

This paper deals with MIMO channel modeling in underground transport environments like tunnels for various antenna array configurations at both the transmitting and receiving sides. MIMO channel matrices have been computed with a full 3D ray-tracing and modeled using correlation based analytical models, like the Kronecker and the Weichselberger models. First, two different modeling strategies are investigated. The first one is computed over all the tunnel length. The second one takes into account the transmitter-receiver distance. In the latter solution, it is possible to isolate specific areas in the tunnel with different correlation properties and take them into account in a system simulation. Then, these two modeling are compared in terms of mean channel capacity results.

## 1. INTRODUCTION

New technologies of communication and information are today key components for mass transit systems operation with applications such as control and command, embedded surveillance, maintenance reporting or video on demand [1]. These wireless systems are often deployed using radiating cable or antennas using free propagation in tunnels. The wireless systems must be able to maximize data rate (several applications on the same radio medium) or robustness (decreasing the radio access points number or increasing the QoS for video) while avoiding the increase in transmitting power and/or transmission bandwidth consumption.

Since few years, MIMO (Multiple-Input – Multiple-Output) systems appear to answer the needs for robust and high-data rate communications, without an additional power or bandwidth consumption [2]. In an environment full of multipaths, the use of antenna arrays at both the transmitting and receiving sides leads to the identification of several independent propagation channels which are linked to the rank of the channel matrix  $\mathbf{H}$  [3][4]. The capacity of the MIMO channel depends on this rank. With spatial correlation or “key hole” effect in the channel, the  $\mathbf{H}$  matrix will be degenerated [5][6]. Previous works have shown the interest and efficiency of such a system in transport environments [7]. Nevertheless, in a tunnel environment when there is no train, the number of scatters is generally low as well as the spread of the angle of

arrival of the rays due to the guided effect. In this context the use of MIMO systems and their efficiency is not obvious [8].

The modal theory [9] shows that in infinite rectangular cross section tunnels, free propagation is possible when the transverse dimensions are large compared to the wavelength. In this specific case, the tunnel can be compared to an oversized lossy waveguide. In this condition, the modal theory shows that only the hybrids modes denoted  $\text{EH}_{mn}$  are able to propagate, where  $m$  and  $n$  stand for the mode order. The higher order modes are very numerous near the transmitter, and fade rapidly with the increasing of the distance between the transmitter and the receiver [10]. Far from the transmitter, it remains only two main modes which interfere together. From [10], three areas can be clearly identified: 1) approximately from 0 to 150 m, 2) from 150 to 400 m, 3) from 400 m to infinite. According to the decrease of the active modes number, the full rank of the channel matrix  $\mathbf{H}$  can not be guaranteed over all the tunnel length. Subsequently, the ergodic channel capacity  $C$  (1) decreases significantly.

$$C = \log_2 \left[ \det \left( I + \frac{\rho}{N_{TX}} \mathbf{H}\mathbf{H}^H \right) \right] \quad (1)$$

where  $N_{TX}$  is the elements number of the transmitter array, and  $\rho$  is the Signal-to-Noise Ratio (SNR).

Assuming these three specific areas in the tunnel, a global MIMO channel modeling over all the tunnel length seems not to be valid and accurate.

In this paper, we investigate the 4 x 4 MIMO channel properties for several antenna configurations in a tunnel and on the trains. A full 3D ray-tracing based wave propagation simulator [11] is used to compute the deterministic channel matrix  $\mathbf{H}$  according to the transmitter-receiver distance. In this paper, two channel modeling are proposed. First, the channel is modeled in a global way over all the tunnel length, using the Kronecker [12] and the Weichselberger [13] MIMO models. Then, the tunnel is separated in multiple areas to ensure the stationarity of the correlation properties. In each area, the channel is modeled using both the Kronecker [12] and the Weichselberger [13] models. Then we present a comparative study between these specific channel models and the deterministic simulation results in terms of mean channel capacity.

	tunnel	train
Relative permittivity $\epsilon_r$	10	2
Conductivity $\sigma$ (S.m <sup>-1</sup> )	0.01	$10^8$

Table 1: Electrical properties used to model the objects of the environment

This paper is structured as follows. We first introduce in Section 2 the configurations simulated thanks to a ray-tracing and the Kronecker and Weichselberger models. In Section 3, the influence of the geometric configuration of the antennas, in the tunnel and on the trains, on the average correlation at the receiver is analyzed. In Section 4, the influence of the channel modeling considering a global model and a second one subdivided in two separate ones according to the correlation level is discussed. We will then conclude and give the perspectives to these works.

## 2. MIMO CHANNEL SIMULATIONS

Firstly, we present the tested configurations, varying the geometric configurations of the antennas in the tunnel and on the trains. The channel matrix has been simulated thanks to a 3D ray-tracing based wave propagation software [11] for each antenna configuration. It computes all the possible paths followed by an electromagnetic wave between a receiver and a transmitter, assuming electromagnetic parameters (relative permittivity and conductivity) for the objects considered in the scene. A previous study has shown that the channel matrix  $\mathbf{H}$  can be studied in narrowband [8] for the considered configurations. In this paper, this MIMO channel matrix  $\mathbf{H}$  is used to model the channel using existing MIMO channel models such as the Kronecker [12] and the Weichselberger [13] models. These channel models are detailed in a second step.

### 2.1. Description of the tested configurations

Several realistic configurations are simulated, varying the position of the trains in a tunnel and the orientation of the transmitter and the receiver antennas. The tunnel dimensions for a 1-track are as follows: 4.5 x 4.5 x 500 m, while the train dimensions are: 3 x 4 x 120 m. Figure 1 illustrates this configuration. Table 1 gives the relative permittivity and the conductivity of the materials used to model the environment.

Both transmitter and receiver antennas are composed with four elements disposed at various places as indicated in Figure 2. The four transmitters are fixed on the tunnel ceiling and each transmitting element is 1 m spaced from the others. Three configurations are tested (TP1, TP2 and TP3), varying the angle between the orientation of the transmitter axis and the main direction of the tunnel. The coordinates of the elements of each antenna configurations are given in Table 2.

Channel matrices  $\mathbf{H}$  are computed for all transmitter-receiver configurations over all the tunnel length from 0 to 500 m with a sampling computation distance equal to 0.5 m.

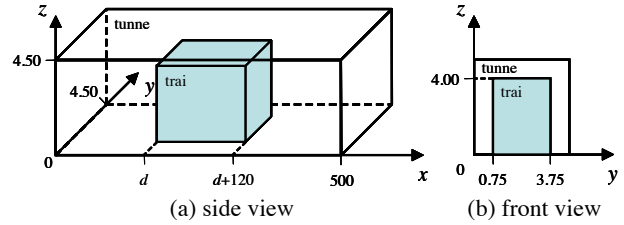

Figure 1: Shapes and dimensions of the studied environment

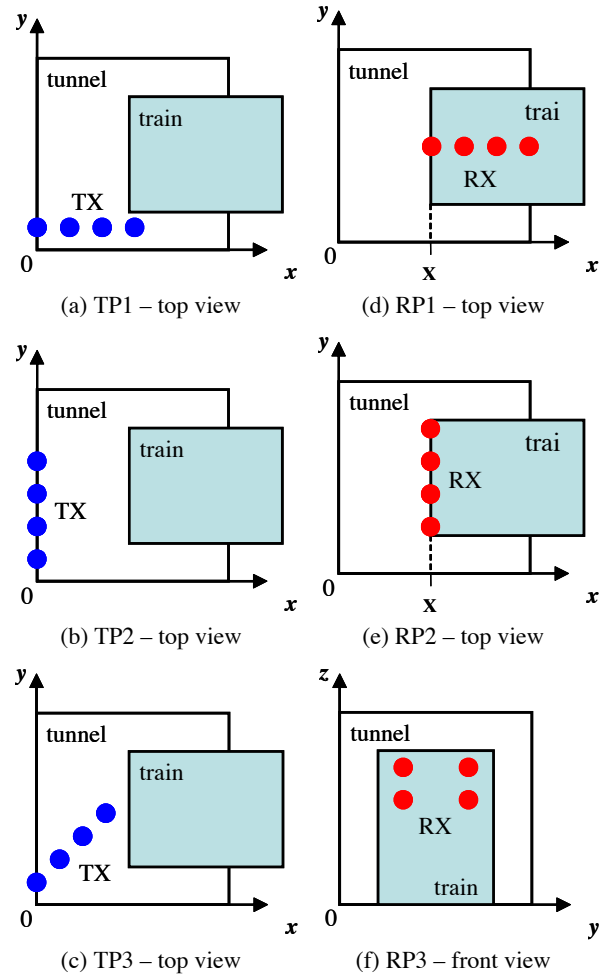

Figure 2: Antenna configurations at both the transmitting (TPx) and the receiving (RPx) sides

### 2.2. Channel modeling

The development and the evaluation of new digital wireless transmission systems need faithful channel models. A lot of models exist in the literature, and they can be classified in two main categories [14].

	x	y	z
TP1	{0 ; 1 ; 2 ; 3}	0.20	4.30
TP2	0	{0.2 ; 1.2 ; 2.2 ; 3.2}	4.30
TP3	{0 ; 0.707 ; 1.414 ; 2.211}	{0.20 ; 0.907 ; 1.614 ; 2.411}	4.30
RP1	X+{0 ; 0.65 ; 1.3 ; 1.95}	2.25	4.10
RP2	X	{1.275 ; 1.925 ; 2.575 ; 3.225}	4.10
RP3	X	{1.6 ; 1.6 ; 2.9 ; 2.9}	{3.80 ; 3.15 ; 3.80 ; 3.15}

Table 2: Element coordinates (m) for each antenna configuration

“Physical models” are often based on an accurate geometrical description of the propagation environment. They can be deterministic, when they use channel parameters deduced from measurement campaigns or simulation tools (with a 3D ray-tracing based simulator for example) [15]. In this case, the accuracy is high, as the cost in materials, human or computing resources. To cancel previous drawbacks, researchers have developed many statistical physical models, based on the characterization of the scatters present in the propagation environment [16]. The most used for example are the one-ring and two-ring models [5] and the distributed scatters model [17]. The major drawback of these models remains the determination of the scatters distributions in the environment.

“Analytical models” or “stochastic models” are independent of the geometric environment description. They are based on the statistical properties of the channel such as the correlation computed from measurements or simulations. There are different possibilities to take into account the correlation between the arrays elements at the receiver and at the transmitter but also in the channel. Several stochastic models were compared in [18]. One of the simplest is the Kronecker model [12] assuming perfect independence of the correlation between transmission and reception sides, while the coupling between the arrays elements can be taken into account using the Weichselberger model [13].

The two models are based on the following decomposition of the channel matrix  $\mathbf{H}$ , composed with complex coefficients, which can be written as follows:

$$\text{vec}(\mathbf{H}) = \mathbf{R}_{\mathbf{H}}^{1/2} \mathbf{g} \quad (2)$$

where  $\mathbf{R}_{\mathbf{H}}$  is the correlation or covariance matrix of the channel,  $\mathbf{g}$  is an i.i.d. random fading vector with unit variance and the operator  $\text{vec}()$  stacks a matrix into a vector, columnwise.

1) *Kronecker model*: The Kronecker model assumes a correlation at the transmitter independent from the correlation at the receiver. So the total correlation of the channel  $\mathbf{R}_{\mathbf{H}}$  can be expressed as the Kronecker product ( $\otimes$ ) of the correlation matrices at the transmitter  $\mathbf{R}_{TX}$  and at the receiver  $\mathbf{R}_{RX}$ :

$$\mathbf{R}_{\mathbf{H}} = \mathbf{R}_{TX} \otimes \mathbf{R}_{RX} \quad (3)$$

Thus, using (3) in (2), we obtain the following relation for the Kronecker model:

$$\mathbf{H} = \mathbf{R}_{RX}^{1/2} \mathbf{G} (\mathbf{R}_{TX}^{1/2})^T \quad (4)$$

Notice that the covariance matrices can be used instead of the correlation matrices in (4). This formulation is very simple and easily usable once we have obtained the correlation/covariance matrices.

2) *Weichselberger model*: Contrary to the Kronecker model, the Weichselberger model takes into account the correlation in the channel between the transmitter and the receiver.

Its formulation is based on the well known Singular Value Decomposition (SVD) of the correlation matrices  $\mathbf{R}_{TX}$  and  $\mathbf{R}_{RX}$ , as:

$$\mathbf{R}_{TX} = \mathbf{U} \mathbf{\Lambda}_{TX} \mathbf{U}^H \quad (5)$$

$$\mathbf{R}_{RX} = \mathbf{V} \mathbf{\Lambda}_{RX} \mathbf{V}^H \quad (6)$$

where:

- $\mathbf{U}$  and  $\mathbf{V}$  are unitary matrices of which the columns are composed with the eigen vectors of  $\mathbf{R}_{TX}$  and  $\mathbf{R}_{RX}$  respectively.
- $\mathbf{\Lambda}_{TX}$  and  $\mathbf{\Lambda}_{RX}$  are diagonal matrices composed with the eigen values of  $\mathbf{R}_{TX}$  and  $\mathbf{R}_{RX}$  respectively.

Using (5) and (6) in (4), the following relation can be obtained:

$$\mathbf{H} = \mathbf{U} (\mathbf{\Omega} \bullet \mathbf{G}) \mathbf{V}^T \quad (7)$$

where  $\bullet$  is the Schur-Hadamard product, and traduces the coupling between the transmitter and the receiver. Its coefficients  $w_{mn} > 0$  are equal to:

$$w_{mn} = \sqrt{E_{\mathbf{H}} \left[ \left| \mathbf{U}_m^H \mathbf{H} \mathbf{V}_n^* \right|^2 \right]} \quad (7)$$

### 3. CHANNEL CORRELATION

In this section, the influence of the geometric configuration of the antennas on the average correlation at the receiver is studied. For each position of the train in the tunnel, the correlation at the receiver is computed from the channel matrices  $\mathbf{H}$  and averaged over the overall tunnel length. Each channel matrix  $\mathbf{H}$  has been simulated using a ray-tracing based software at 2.4 GHz.

Figure 3 presents the average correlation coefficients according to the distance for all the 9 transmitter-receiver combinations. It highlights the increase of the average correlation coefficient with the transmitter-receiver distance when the transmitter and/or the receiver arrays (TP1 x RPx, TPx x RP1) are oriented in the tunnel direction  $x$ . In these specific cases, two areas can be distinguished. The first one, called “A1”, starts from 0 m to 150 m and shows fluctuations of the values. The second one, named “A2”, starts from 150 m to 500 m presents high average correlation values roughly equal to 1.

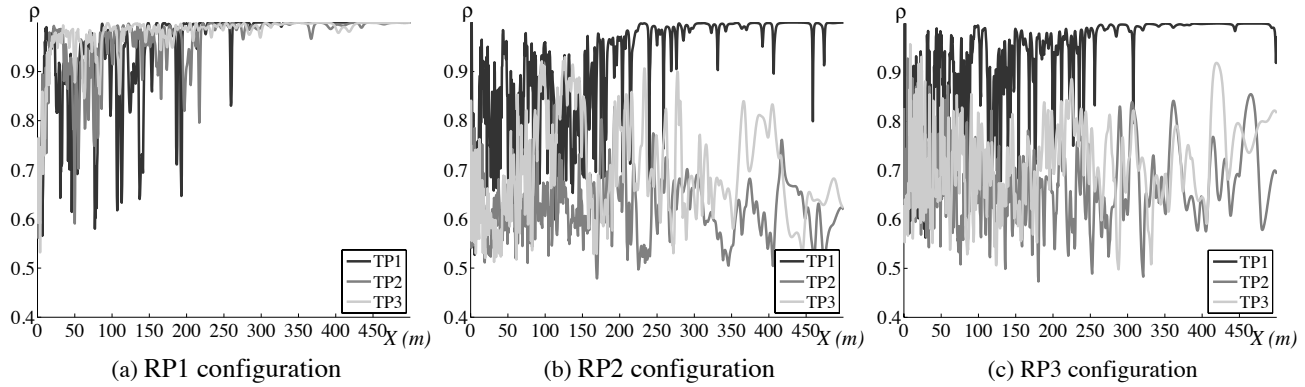
Figure 3: Average correlation coefficient  $\rho$  at the receiver for various configurations at 2.4 GHz

	TP1		TP2		TP3	
	A1	A2	A1	A2	A1	A2
RP1	0.87	0.99	0.91	0.99	0.94	0.99
RP2	0.82	0.97	0.63	0.62	0.72	0.69
RP3	0.85	0.98	0.68	0.67	0.69	0.73

Table 3: Average correlation coefficient  $\rho$  for all TP $_x$ /RP $_x$  configurations at 2.4 GHz in A1 and A2 areas

On the contrary, the correlation coefficient at the receiver is quite constant over all the tunnel length for specific antenna configurations. The main orientation of these antenna arrays is transverse to the axis of the tunnel (TP2 x RP2 for example). These configurations lead to a smaller coefficient correlation due to the increase of the spatial diversity. The solution which consists in positioning the antenna arrays onto the back windshield of the train shows similar performance.

Table 3 summarizes the correlation coefficient averaged over both areas A1 and A2 identified previously. It appears that the correlation in the TP $_i$  x RP $_j$ ,  $i, j \in [2, 3]$  configurations is small (about 0.65) and is independent from the transmitter-receiver distance. When the angle between the array and the tunnel axis is reduced to 0 (at least TP1 or RP1), the mean correlation values are different in each area. In the area A1 (first 150 m), the mean correlation values are comprised between 0.8 and 0.9, while they reached 0.99 in the area A2 (from 150 to 500 m). This behavior difference between the two areas in these specific configurations can be modeled in a different way.

#### 4. CHANNEL MODELING

The previous section has shown that the mean correlation at the receiver can evolve significantly when the distance between the transmitter and the receiver increases. This behavior has been observed particularly when the transmitter and/or the receiver are oriented in the same axis that the tunnel direction. In this section, we show that the channel modeling can be improved considering the two identified areas in a different way.

Figure 4 shows the mean channel capacity results using the channel matrices  $\mathbf{H}$  obtained respectively from the simulations, the Kronecker model and the Weichselberger model in the TP1 x RP1 configuration. It appears that the choice of a specific model is different if we consider the global behavior over all the tunnel length, or only the A1 and A2 areas.

Over all the tunnel length, the Kronecker model gives good results in terms of mean channel capacity, unlike the Weichselberger one. This behavior can also be observed in the area A2 where the correlation level is maximal. On the contrary, in the area A1, the Weichselberger model gives the best results.

The different values of the correlation level according to the distance leads to a great error onto the mean channel capacity over all the tunnel length. The estimated channel capacity for a SNR = 30 dB is equal to 17.6 bit/s/Hz. This estimation is far from the mean values obtained in the two areas A1 and A2: 24.8 bit/s/Hz and 14.4 bit/s/Hz, respectively.

These observations have been generalized in the other antenna configurations for which a high correlation degree far from the transmitter is obtained when the transmitter and/or receiver arrays are oriented according to the axis of the tunnel.

On the contrary, when the correlation coefficient is quite constant over all the tunnel length, the Kronecker model gives best results simultaneously in both areas A1 and A2, which is the case in the TP2 x RP2 configuration. Moreover, the impact of the various areas on the mean channel capacity values is not significant. It is useful to identify different areas in the tunnel if the correlation level varies significantly with the transmitter-receiver distance. With such consideration, an accurate description of the channel capacity in the different areas of the tunnel can be obtained.

#### 5. CONCLUSION

This paper has presented a preliminary study focused on the importance of the MIMO channel modeling for underground tunnels. Based on the study of the mean correlation level at the receiver, the tunnel is subdivided in two areas. The first one called "A1" starts from 0 to 150 m; the second one named "A2" starts from 150 to 500 m.

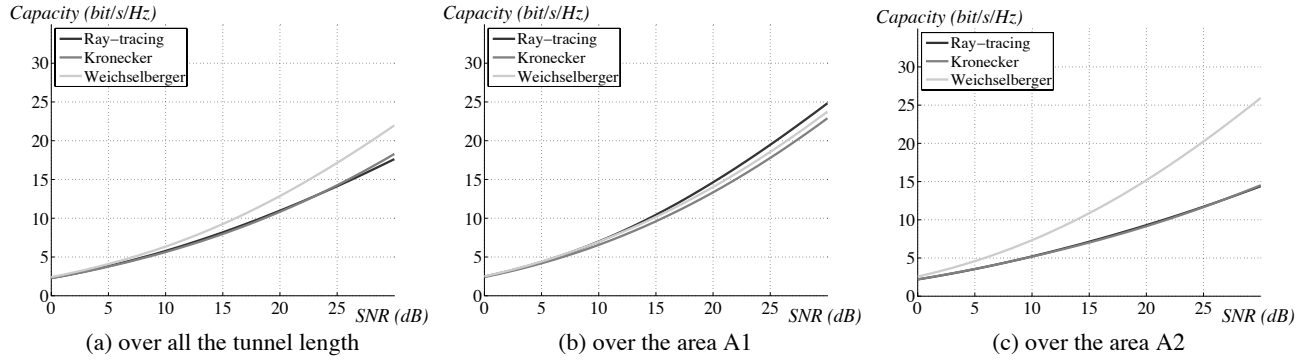

Figure 4: Mean channel capacities for the simulated channel matrices  $\mathbf{H}$  using a ray-tracing based software and the both Kronecker and Weichselberger models – TP1 x RP1 (2.4 GHz)

It has been shown that these two areas have an important consequence on the channel modeling if the correlation level evolves significantly with the distance between the transmitter and the receiver (antenna arrays oriented in the axis of the tunnel). When the correlation level is quite constant over all the tunnel length (antenna array perpendicular to the tunnel axis), it is sufficient to consider only a single area.

In future works, we will then focus on the improvement of the channel modeling results in this configuration (empty tunnel) and in more complicated ones (presence of a masking train, 2-track tunnels). Measurements are planned to validate this approach.

## 6. ACKNOWLEDGEMENTS

This work was performed in the framework of the PREDIT research project MOCAMIMODYN (MODèles de CANaux MIMO DYNAMIQUES en tunnels pour des applications transport public) in the I-Trans Cluster. The authors would like to thank the National Research Agency (ANR) for financial support.

## 7. REFERENCES

- [1] M. Berbineau, "Existing or emerging telecommunication systems and their use in guided transports," *Synthèse INRETS*, vol. 40, November 2001.
- [2] G. Foschini and M. Gans, "On limits of wireless communications in a fading environment when using multiple antennas," *Wireless Personal Multimedia Communications*, pp. 311–335, June 1998.
- [3] Y. Berezansky, Z. Sheftel, and G. Us, *Functional analysis*. Birkhauser Verlag, 1996, vol. 1.
- [4] R. Gallager, *Elements of information theory*. New York: Wiley, 1968.
- [5] D. Shiu, G. Foschini, M. Gans, and J. Kahn, "Fading correlation and its effect on the capacity of multi-element antenna systems," *IEEE Trans. Commun.*, vol. 48, no. 3, pp. 502–513, March 2000.
- [6] D. Chizhik, G. Foschini, and R. Valenzuela, "Capacity of multi element transmit and received antennas: Correlation and keyholes," *Electron. Lett.*, pp. 1099–1100, 2000.
- [7] G. Moniak, M. Berbineau, and J. Pardonche, "Robust and high data rate transmissions for security between a bus and a control center," in *VTC '2004-Fall Proceedings*, vol. 2. Los Angeles, USA: IEEE, September 2004, pp. 1377–1381.
- [8] Y. Cocheril, P. Combeau, M. Berbineau, Y. Pousset, "MIMO propagation channel characteristics in tunnels," in *ITST '2007*, Nice, France, June 2007, pp. 1–6.
- [9] K. Laakman and W. Steier, "Waveguides: characteristic modes of hollow rectangular dielectric waveguides," *Appl. Opt.*, vol. 15, no. 5, pp. 1334–1340, May 1976.
- [10] M. Lienard, P. Degauque, Molina-Garcia-Pardo, and J. Maria, "Wave propagation in tunnels in a mimo context – a theoretical and experimental study," *Comptes Rendus Physique*, vol. 7, no. 7, pp. 726–734, September 2006.
- [11] Y. Chartois, Y. Pousset, and R. Vauzelle, "A siso and mimo radio channel characterization with 3d ray tracing propagation model in urban environment," in *ECPS '2005 Proceedings*. Brest, France: IEEE, March 2005.
- [12] J. Kermoal, L. Schumacher, K. Pedersen, P. Mogensen, and F. Frederiksen, "A stochastic mimo radio channel model with experimental validation," *IEEE J. Sel. Areas Commun.*, vol. 20, no. 6, pp. 1211–1226, August 2002.
- [13] W. Weichselberger, M. Herdin, H. Ozelik, and E. Bonek, "A stochastic mimo channel model with joint correlation of both link ends," *IEEE Trans. Wireless Commun.*, vol. 5, no. 1, pp. 90–100, January 2006.
- [14] P. Almers, E. Bonek, A. Burr et al., "Survey of channel and radio propagation models for wireless mimo systems," *EURASIP Journal on Wireless Communications and Networking*, vol. 2007, p. 19 pages, 2007.
- [15] L. Schumacher, L. Berger, and J. Ramiro-Moreno, "Recent advances in propagation characterisation and multiple antenna processing in the 3gpp framework," in *26th URSI General Assembly Proceedings*, Maastricht, The Netherlands, August 2002.
- [16] K. Yu and B. Ottersten, "Models for mimo propagation channels: a review," *Wireless Communications and Mobile Computing*, vol. 2, no. 7, pp. 653–666, November 2002.
- [17] D. Gesbert, H. Bolcskei, D. Gore, and A. Paulraj, "Outdoor mimo wireless channels: models and performance," *IEEE Trans. commun.*, vol. 50, no. 12, pp. 1926–1934, 2002.
- [18] J. Pardonche, M. Berbineau, and C. Seguinot, "Présentation de quelques modèles stochastiques de canal mimo et comparaison expérimentale," *Annales des télécommunications*, vol. 60, no. 5–6, pp. 649–690, 2005.