



HAL
open science

Enumeration of Pin-Permutations

Frédérique Bassino, Mathilde Bouvel, Dominique Rossin

► **To cite this version:**

Frédérique Bassino, Mathilde Bouvel, Dominique Rossin. Enumeration of Pin-Permutations. 2008.
hal-00348664v1

HAL Id: hal-00348664

<https://hal.science/hal-00348664v1>

Preprint submitted on 19 Dec 2008 (v1), last revised 5 Mar 2011 (v2)

HAL is a multi-disciplinary open access archive for the deposit and dissemination of scientific research documents, whether they are published or not. The documents may come from teaching and research institutions in France or abroad, or from public or private research centers.

L'archive ouverte pluridisciplinaire **HAL**, est destinée au dépôt et à la diffusion de documents scientifiques de niveau recherche, publiés ou non, émanant des établissements d'enseignement et de recherche français ou étrangers, des laboratoires publics ou privés.

Enumeration of Pin-Permutations*

Frédérique Bassino

LIPN, UMR 7030
Université Paris 13 - CNRS
99, avenue Jean-Baptiste Clément
93430 Villetaneuse, France

Mathilde Bouvel

Dominique Rossin
LIAFA, Université Paris Diderot
CNRS, UMR 7089, Case 7014
75205 Paris Cedex 13, France

December 19, 2008

Abstract

In this paper, we study the class of pin-permutations, that is to say of permutations having a pin representation. This class has been recently introduced in [16], where it is used to find properties (algebraicity of the generating function, decidability of membership) of classes of permutations, depending on the simple permutations this class contains. We give a recursive characterization of the substitution decomposition trees of pin-permutations, which allows us to compute the generating function of this class, and consequently to prove, as it is conjectured in [18], the rationality of this generating function. Moreover, we show that the basis of the pin-permutation class is infinite.

1 Introduction

In the combinatorial study of permutations, *simple permutations* have been the core objects of many recent works [2, 3, 14, 16, 17, 18, 20]. These simple permutations are the “building blocks” on which all permutations are built, through their *substitution decomposition*. Similar decompositions for other objects have been widely used in the literature: for relations [25, 26, 31, 33], for graphs [13, 35], or in a variety of other fields [19, 22, 34]. Substitution decomposition of permutations has been recently introduced in combinatorics [2], and used to exhibit relations between the basis of permutations classes, and the simple permutations this class contains [16, 17, 18].

In the algorithmic field, the substitution decomposition (or *interval decomposition*) of permutations has been defined in [5, 6, 37]. It takes its roots in the *modular decomposition of graphs* (see for example [13, 21, 29, 35, 36]), where prime graphs play the same key role as simple permutations. Some examples of an algorithmic use of the substitution decomposition of permutations are the computation of the set of common intervals of two (or more) permutations [6, 37], with applications to bio-informatics [5], or restricted versions of the longest common pattern problem among permutations [8, 11, 12, 28].

In the study of substitution decomposition, there is a major difference between algorithmics and combinatorics: algorithms proceed through the *substitution decomposition tree* of permutations, that is to say recursively decompose every block appearing in the substitution

*This work was completed with the support of the ANR project GAMMA number 07-2.195422

decomposition of a permutation. On the contrary, in combinatorics, the substitution decomposition is mostly interested in the *skeleton* of the permutation, which corresponds to the root of its decomposition tree.

In the present work, we take advantage of both points of view, and use the substitution decomposition tree with a combinatorial purpose. We deal with permutations that admit *pin representations*, denoted *pin-permutations*. These permutations were introduced recently by Brignall et al. in [16] when studying the links between simple permutations and classes of pattern avoiding permutations, from an enumerative point of view. The authors conjectured that the class of pin-permutations has a rational generating function. We prove this conjecture, focusing on the substitution decomposition trees of pin-permutations.

In Section 2, we start with recalling the definitions of substitution decomposition and of pin-permutations, and describe some of their basic properties. The core of this work is the proof of Theorem 3.1 which gives a complete characterization of the decomposition trees of pin-permutations. This corresponds to Section 3. Section 4 focuses on the enumeration of *simple* pin-permutations, using the notion of *pin words* defined in [18]. With this enumerative result and the characterization of Theorem 3.1, standard enumerative techniques [24] allow us to obtain the generating function of the pin-permutation class in Section 5. This generating function being rational, this settles a conjecture of [18]. Finally, in Section 6, we are interested in the basis of the pin-permutation class: we prove that the excluded patterns defining this class of permutations are in infinite number.

2 Preliminaries

2.1 Permutations and patterns

A permutation σ of size n is a bijective map from $[1..n]$ to itself. We denote by σ_i the image of i under σ . For example the permutation $\sigma = 1\ 4\ 2\ 5\ 6\ 3$ is the bijective function such that $\sigma(1) = 1$, $\sigma(2) = 4$, $\sigma(3) = 2$, $\sigma(4) = 5 \dots$

Definition 2.1. *The graphical representation of a permutation $\sigma \in S_n$ is the set of points in the plane at coordinates $(1, \sigma(1)), (2, \sigma(2)), \dots, (n, \sigma(n))$.*

Definition 2.2. *The bounding box of a set of points E is defined as the smallest axis-parallel rectangle containing the set E in the graphical representation of the permutation (see Figure 1). This box defines several regions in the plane:*

- *The sides of the bounding box (U, L, R, D on Figure 1).*
- *The corners of the bounding box ($1, 2, 3, 4$ on the Figure 1).*
- *The bounding box itself.*

Definition 2.3. *A permutation $\pi = \pi_1 \dots \pi_k$ is called a pattern of the permutation $\sigma = \sigma_1 \dots \sigma_n$, with $k \leq n$, if and only if there exist integers $1 \leq i_1 < i_2 < \dots < i_k \leq n$ such that $\sigma_{i_\ell} < \sigma_{i_m}$ whenever $\pi_\ell < \pi_m$. We will also say that σ contains π . A permutation σ that does not contain π as a pattern is said to avoid π .*

Figure 1 Graphical representation of $\sigma = 12131131710298564$ and the bounding box of $\{7, 2, 9, 5, 6\}$.

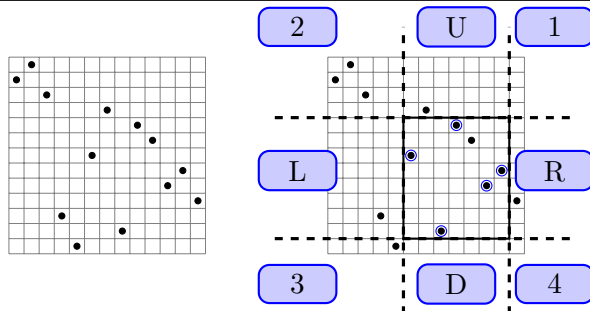

Example 2.1. The permutation $\sigma = 142563$ contains the pattern 1342 whose occurrences are 1563 , 1463 , 2563 and 1453 . But σ avoids the pattern 321 as none of its subsequences of length 3 is order-isomorphic to 321 , i.e. is decreasing.

We write $\pi \prec \sigma$ to denote that π is a pattern of σ . This pattern-containment relation is a partial order on permutations, and permutation classes are downsets under this order. In other words, a set \mathcal{C} is a permutation class if and only if for any $\sigma \in \mathcal{C}$, if $\pi \prec \sigma$, then $\pi \in \mathcal{C}$. Any class \mathcal{C} of permutations can be defined by a set B of excluded patterns (see for example [2, 10]), called the *basis* of \mathcal{C} : $\sigma \in \mathcal{C}$ if and only if σ avoids every pattern in B . The basis of a class of pattern-avoiding permutations may be finite or infinite.

Permutation classes have been widely studied in the literature, mainly from a pattern-avoidance point of view. See [9, 23, 30, 38] among many others. The main result about the enumeration of permutation classes is the recent proof of the Stanley-Wilf by Marcus and Tardos [32], who established that for any class \mathcal{C} , there is a constant c such that the number of permutations of size n in \mathcal{C} is at most c^n .

Throughout this paper, we use the decomposition tree of permutations to characterize pin-permutations. In these trees, permutations are decomposed along two different rules in which two special kinds of permutation appear, the *simple* permutations and the *linear* ones.

Strong intervals and simple permutations, whose definitions are recalled below, are the two key concepts involved in substitution decomposition. We refer the reader to [2, 3, 14] for more details about simple permutations.

Definition 2.4. An interval or block in a permutation σ is a set of consecutive values whose images by σ form a set of consecutive values. A strong interval is an interval that does not overlap any other interval.

Definition 2.5. A permutation σ is simple when its non-empty intervals are exactly the trivial ones: the singletons and σ .

Notice that the smallest simple permutations are 12 , 21 , 2413 and 3142 . In particular, there are no simple permutations of size 3. We will consider that 12 and 21 are *not* simple permutations. Hence, simple permutations are of size at least 4.

If σ is a permutation of S_n and $\pi \in S_p$ then substituting π in σ at position i leads to the permutation $\alpha = \bar{\sigma}_1 \bar{\sigma}_2 \dots \bar{\sigma}_{i-1} (\pi_1 + \sigma_i - 1) \dots (\pi_p + \sigma_i - 1) \bar{\sigma}_{i+1} \dots \bar{\sigma}_{n+p-1}$ where

$\bar{\sigma}_j = \begin{cases} \sigma_j & \text{if } \sigma_j \leq \sigma_i, \\ p + \sigma_j - 1 & \text{otherwise.} \end{cases}$ For convenience, as multiple substitution can occur in a permutation we will denote by $\sigma[1, 1, \dots, 1, \underbrace{\pi}_i, 1]$ this substitution. This notation naturally

generalizes to $\sigma[\pi_1, \pi_2, \dots, \pi_n]$, and it has already been defined in [2] under the name of *inflation*. Consider for example the substitution of $\pi = 3\ 1\ 2\ 4$ in $\sigma = 2\ 5\ 4\ 6\ 7\ 1\ 3$ at position 3 (i.e. replacing $\sigma_3 = 4$). We obtain permutation $\alpha = 2\ 8\ \mathbf{6}\ \mathbf{4}\ \mathbf{5}\ \mathbf{7}\ 9\ 10\ 1\ 3$ and write $\alpha = 2\ 5\ 4\ 6\ 7\ 1\ 3[1, 1, 3\ 1\ 2\ 4, 1, 1, 1, 1]$. This operation of substitution is easier to describe on the graphical representation of permutations: the graphical representation of $\sigma[\pi_1, \pi_2, \dots, \pi_n]$ is obtained from the one of σ by replacing each point σ_i by a block containing the graphical representation of π_i .

We have now all the basic concepts necessary to define decomposition trees. For any $n \geq 2$, let I_n be the permutation $1\ 2\ \dots\ n$ and D_n be $n\ (n-1)\ \dots\ 1$. We use the notations \oplus and \ominus for denoting respectively I_n and D_n , for any $n \geq 2$. Notice that in inflations of the form $\oplus[\pi_1, \pi_2, \dots, \pi_n] = I_n[\pi_1, \pi_2, \dots, \pi_n]$ or $\ominus[\pi_1, \pi_2, \dots, \pi_n] = D_n[\pi_1, \pi_2, \dots, \pi_n]$, the integer n is determined without ambiguity by the number of permutations π_i of the inflation.

Definition 2.6. *A permutation σ is \oplus -indecomposable (resp. \ominus -indecomposable) if it cannot be written as $\oplus[\pi_1, \pi_2, \dots, \pi_n]$ (resp. $\ominus[\pi_1, \pi_2, \dots, \pi_n]$), for any $n \geq 2$.*

Theorem 2.1. (first appeared implicitly in [27]) *Every permutation $\sigma \in S_n$ can be uniquely decomposed as either:*

- $\oplus[\pi_1, \pi_2, \dots, \pi_k]$, with $\pi_1, \pi_2, \dots, \pi_k$ \oplus -indecomposable,
- $\ominus[\pi_1, \pi_2, \dots, \pi_k]$, with $\pi_1, \pi_2, \dots, \pi_k$ \ominus -indecomposable,
- $\alpha[\pi_1, \dots, \pi_k]$ with α a simple permutation.

It is important for stating Theorem 2.1 that 12 and 21 are not considered as simple permutations. An equivalent version of this theorem, which includes 12 and 21 among simple permutations, is given in [2]. Notice that the π_i 's correspond to strong intervals in the permutation σ , and are necessarily the *maximal* strong intervals of σ strictly included in $\{1, 2, \dots, n\}$. Another important remark is that:

Fact 2.1. *Any block of $\sigma = \alpha[\pi_1, \dots, \pi_k]$ (with α a simple permutation) is either σ itself, or is included in one of the π_i 's.*

For example, $\sigma = 1\ 2\ 4\ 3\ 5$ can be written either as $1\ 2\ 3[1, 1, 2\ 1\ 3]$ or $1\ 2\ 3\ 4[1, 1, 2\ 1, 1]$ but in the first form, $\pi_3 = 2\ 1\ 3$ is not \oplus -indecomposable, thus we use the second decomposition. The decomposition theorem 2.1 can be applied recursively on each π_i leading to a complete decomposition where each permutation which appears is either I_k, D_k (denoted by \oplus, \ominus respectively) or a simple permutation.

Example 2.2. *Let $\sigma = 10\ 13\ 12\ 11\ 14\ 1\ 18\ 19\ 20\ 21\ 17\ 16\ 15\ 4\ 8\ 3\ 2\ 9\ 5\ 6\ 7$. Its recursive decomposition can be written as*

$$3\ 1\ 4\ 2[\oplus[1, \ominus[1, 1, 1], 1], 1, \ominus[\oplus[1, 1, 1, 1], 1, 1, 1], 2\ 4\ 1\ 5\ 3[1, 1, \ominus[1, 1], 1, \oplus[1, 1, 1]]].$$

Figure 2 The substitution decomposition tree and the graphical representation (with non-trivial strong intervals marked by rectangles) of permutation $\sigma = 10\ 13\ 12\ 11\ 14\ 1\ 18\ 19\ 20\ 21\ 17\ 16\ 15\ 4\ 8\ 3\ 2\ 9\ 5\ 6\ 7$.

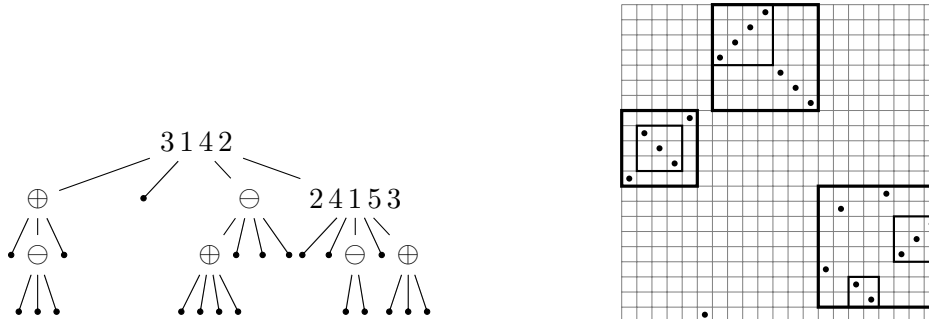

The substitution decomposition recursively applied to maximal strong intervals leads to a tree representation of this decomposition where a substitution $\alpha[\pi_1, \dots, \pi_k]$ is represented by a node labeled α with k ordered children representing the π_i 's. In the sequel we will say the child of a node V instead of the permutation corresponding to the subtree rooted at a child of node V .

Definition 2.7. *The substitution decomposition tree T of the permutation σ is the unique labeled ordered tree encoding the substitution decomposition of σ , where each internal node is either labeled by \oplus, \ominus -those nodes are called linear- or by a simple permutation α -prime nodes-. Each node labeled by α has arity $|\alpha|$ and each subtree maps onto a strong interval of σ .*

Notice that in substitution decomposition trees, there are no edges between two nodes labeled by \oplus , nor between two nodes labeled by \ominus , since the π_i 's are \oplus -indecomposable (resp. \ominus -indecomposable) in the first (resp. second) item of Theorem 2.1. See Figure 2 for an example.

Theorem 2.2. [2] *Permutations are in one-to-one correspondence with substitution decomposition trees.*

2.2 Pin representations: basic definitions

We will consider the subset of permutations having a pin representation. This representation was introduced in [16] in order to check whether a permutation class contains only a finite number of simple permutations. Nevertheless, pin representations can be defined without reference to simple permutations.

A *diagram* is a set of points in the plane such that two points never lie on the same line or the same column. Notice that the graphical representation of a permutation is a diagram and that a diagram is not always the graphical representation of a permutation but is order-isomorphic to the graphical representation of a permutation -just delete blank lines and columns from the diagram. In a diagram we say that a pin p *separates* the set E from the set F when E and F lie on different sides from either a horizontal line going through p or a vertical one.

Definition 2.8. Let $\sigma \in S_n$ be a permutation. A pin representation of σ is a sequence of points (p_1, \dots, p_n) of the graphical representation of σ (covering all the points in it) such that each point p_i satisfies both of the following conditions

- the externality condition: p_i lies outside of the bounding box of $\{p_1, \dots, p_{i-1}\}$
- $\left\{ \begin{array}{l} \text{either the separation condition: } p_i \text{ must separate } p_{i-1} \text{ from } \{p_1, \dots, p_{i-2}\}, \\ \text{or the independence condition: } p_i \text{ is not on the sides of the bounding box} \\ \text{of } \{p_1, \dots, p_{i-1}\}. \end{array} \right.$

We say that a pin satisfying the externality and the independence (resp. separation) conditions is an *independent* (resp. *separating*) pin. An example of a pin representation is given in Figure 3.

Figure 3 A pin representation of permutation $\sigma = 18364257$. All pins p_3, \dots, p_8 are separating pins, except p_6 which is an independent pin.

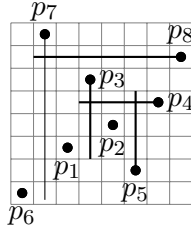

Pin representations in our sense are more restricted than pin sequences in the sense of [16, 18]: a pin representation covers all the points of the permutation, whereas this is not required for a pin sequence. This difference justifies that we use the word *representation* instead of *sequence*. Nevertheless our proper pin representations coincide with the proper pin sequences defined in [16].

Definition 2.9. Let $\sigma \in S_n$ be a permutation. A proper pin representation of σ is a sequence of points (p_1, p_2, \dots, p_n) of the graphical representation of σ such that each point p_i satisfies both the separation and the externality conditions.

Not every permutation has a pin representation, see for example $\sigma = 71238456$. We call *pin-permutation* any permutation that has a pin representation. Pin-permutations correspond to the permutations that can be encoded by *pin words* in the terminology of [16, 18]. In that paper the authors conjecture the following result:

Conjecture 2.1. [18] *The class of pin-permutations has a rational generating function.*

In the sequel we prove this conjecture and exhibit the generating function of pin-permutations. We first study some properties of pin representations.

2.3 Some properties of pin representations

We first give general properties of pin representations and define special families of pin-permutations.

Lemma 2.1. *Let (p_1, \dots, p_n) be a pin representation of $\sigma \in S_n$. Then for each $i \in \{2, \dots, n-1\}$, if there exists a point x on the sides of the bounding box of $\{p_1, \dots, p_i\}$, then it is unique and $x = p_{i+1}$.*

Proof. Consider the bounding box of $\{p_1, p_2, \dots, p_i\}$ and let x be a point on the sides of this bounding box. Suppose without loss of generality that x is above the bounding box. By definition of the bounding box, and since it contains at least two points, x separates $\{p_1, \dots, p_i\}$ into two sets $S_1, S_2 \neq \emptyset$. Now, there exists $l \geq i$ such that $x = p_{l+1}$. Suppose that $l > i$. The bounding box of $\{p_1, \dots, p_l\}$ contains the one of $\{p_1, \dots, p_i\}$ but does not contain x , and thus x is still above it. Consequently, $x = p_{l+1}$ does not satisfy the independence condition. It must then satisfy the separation condition, so that x separates p_l from p_1, \dots, p_{l-1} . But $S_1, S_2 \subset \{p_1, \dots, p_{l-1}\}$ and x separates S_1 from S_2 leading to a contradiction. \square

Any pin representation can be encoded into a word on the alphabet $\{1, 2, 3, 4\} \cup \{R, L, U, D\}$ called a *pin word* associated to the pin representation of the permutation and defined below.

Definition 2.10. *Let (p_1, p_2, \dots, p_n) be a pin representation. For any $k \geq 2$, the pin p_{k+1} is encoded as follows.*

- *If it separates p_k from the set $\{p_1, p_2, \dots, p_{k-1}\}$, thus it lies on one side of the bounding box. Then p_{k+1} is encoded by L, R, U, D in the pin word depending on its position as shown in Figure 1.*
- *If it respects the externality and independence conditions and therein lies in one of the quadrant 1, 2, 3, 4 defined in Figure 1, then this number encodes p_{k+1} in the pin word.*

To encode p_1 and p_2 : choose a fictive point p_0 of the plan and then encode p_1 with the numeral corresponding to the position of p_1 relatively to p_0 and encode p_2 according to its position relatively to the bounding box of $\{p_0, p_1\}$.

Notice that because of the choice of the fictive point p_0 , a pin representation is not associated with a unique pin word. Some pin words associated with the pin representation of $\sigma = 18364257$ given in Figure 3 are $11URD3UR, 3RURD3UR, \dots$

Definition 2.11. *A pin word $w = w_1 \dots w_n$ is a strict pin word if and only if*

- *only w_1 is a numeral,*
- *for any $2 \leq i \leq n-1$, if $w_i \in \{L, R\}$, then $w_{i+1} \in \{U, D\}$,*
- *for any $2 \leq i \leq n-1$, if $w_i \in \{U, D\}$, then $w_{i+1} \in \{L, R\}$.*

A strict pin word is the encoding of a proper pin representation. A proper pin representation corresponds to several pin words.

Lemma 2.2. *Let (p_1, \dots, p_n) be a proper pin representation of $\sigma \in S_n$. Then, for $2 < i < n$, the pin p_i is at a distance of exactly 2 cells from the bounding box of $\{p_1, \dots, p_{i-1}\}$.*

Proof. From Definition 2.9 of proper pin representations, for $2 \leq i < n$, p_{i+1} separates p_i from $\{p_1, \dots, p_{i-1}\}$, therefore p_i is at a distance of at least 2 cells from the bounding box of $\{p_1, \dots, p_{i-1}\}$. Moreover from Definition 2.9 again and Lemma 2.1, for $2 < i < n$, p_i is on the sides of the bounding box of $\{p_1, \dots, p_{i-1}\}$ and p_{i+1} is the only point on the sides of the bounding box of $\{p_1, \dots, p_i\}$. Thus, for $2 < i < n$, p_i is at distance exactly 2 cells from the bounding box of $\{p_1, \dots, p_{i-1}\}$. \square

Lemma 2.3. *Let $p = (p_1, \dots, p_n)$ be a proper pin representation of $\sigma \in S_n$. If the pin p_i is at a corner of the bounding box of $\{p_1, \dots, p_j\}$, then $i = 1$ or 2 .*

Proof. If the pin p_i is at a corner of the bounding box of $\{p_1, \dots, p_j\}$ for some $j \geq i$, then p_i is not on the sides of the bounding box of $\{p_1, \dots, p_{i-1}\}$. As p is a proper pin representation, this happens only when $i = 1$ or 2 . \square

2.4 Weaving and quasi-weaving permutations

Amongst simple permutations some special ones, that we call weaving and quasi-weaving permutations in the sequel, play a key role in the characterization of substitution decomposition trees associated with pin-permutations (see Theorem 3.1).

Definition 2.12 (weaving permutation). *We call weaving permutations the permutations defined as follows. For $n \geq 5$, there are exactly four weaving permutations of size n :*

- If $n \geq 5$ is even, one weaving permutation of size n is

$$\sigma = 2 \underbrace{41} \dots \underbrace{(2p+2)(2p-1)} \dots \underbrace{n(n-3)}(n-1)$$

- If $n \geq 5$ is odd, one weaving permutation of size n is

$$\sigma = 2 \underbrace{41} \underbrace{63} \dots \underbrace{(2p+2)(2p-1)} \dots \underbrace{(n-1)(n-4)} n(n-2)$$

The only three other permutations obtained from the permutation σ above by symmetry (with the inverse and the mirror transform for example) are the other weaving permutations of size n . Moreover there are one weaving permutation of size 1, two weaving permutations of size 2 (12 and 21), four weaving permutations of size 3 (132, 213, 231 and 312) and two weaving permutations of size 4 (2413 and 3142).

Notice that there are in general eight symmetries of a given permutation, but some can be equal. This is the case for weaving permutations: for a weaving permutation σ of size $n \geq 5$, since $\text{mirror}(\sigma)^{-1} = \text{mirror}(\sigma^{-1})$, the eight symmetries of σ describe only four permutations.

Here are a few properties of weaving permutations (see Figure 4) that can be proved by exhaustive verification.

Lemma 2.4. (i) *Weaving permutations of size at least 4 are simple pin-permutations.*

- (ii) *For any weaving permutation of size at least 5, exactly one of the diagonals has the property that every point is at a distance of at most 2 cells from this diagonal.*

Point (ii) of Lemma 2.4 allows us to define the direction of a weaving permutation.

Figure 4 An ascending weaving permutation of size 10 and a descending weaving permutation of size 11, with a pin representation for each.

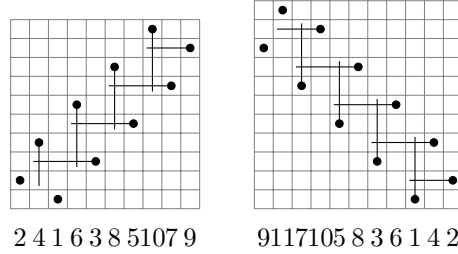

Definition 2.13. A weaving permutation of size $n \geq 5$ is said to be ascending when every point of its graphical representation is at a distance of at most 2 cells from the main diagonal. Otherwise, the weaving permutation is said to be descending. For $n \leq 4$ the ascending weaving permutations are 1, 21, 231, 312, 2413 and 3142, and the descending weaving permutations are 1, 12, 132, 213, 2413 and 3142. Notice that 1, 2413 and 3142 are both ascending and descending.

Lemma 2.5. Any ascending (resp. descending) weaving permutation has proper pin representations whose starting points can be chosen either in the top right hand corner or in the bottom left hand corner (resp. either in the top left hand corner or in the bottom right hand corner).

Proof. This is proved by exhaustive verification for $n \leq 4$. For $n \geq 5$, these proper pin representations are obtained as indicated in the proof of Lemma 2.4 (i). On the weaving permutations σ of odd and even size n given in Definition 2.12, we can check that $1RURU\dots$ and $3LDDL\dots$ when n is even and $1RURU\dots$ and $3DLDL\dots$ when n is odd are pin words that encode such proper pin representations. For every other weaving permutation we conclude with symmetry arguments. \square

We need to introduce a few more definitions:

Figure 5 Two examples of quasi-weaving permutations of size 10 and 11. The points marked M , A and O represent respectively the main and auxiliary substitution points, and the outer point.

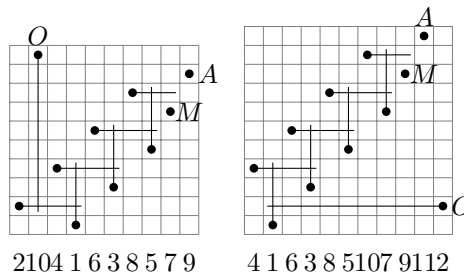

Definition 2.14 (quasi-weaving permutations). *We call quasi-weaving permutations the permutations defined as follows. For $n \geq 6$ there are exactly eight quasi-weaving permutations of size n :*

- If $n \geq 6$ is even, one quasi-weaving permutation of size n is

$$\sigma = 2n \underbrace{41} \underbrace{63} \dots \underbrace{(2p+2)(2p-1)} \dots \underbrace{(n-2)(n-5)}(n-3)(n-1)$$

We define the main substitution point (resp. auxiliary substitution point) of σ as the point of coordinates $(n-1, n-3)$ (resp. $(n, n-1)$) in the graphical representation of σ , and the outer point of σ as the point of coordinates $(2, n)$ in the graphical representation of σ .

- If $n \geq 6$ is odd, one quasi-weaving permutation of size n is

$$\sigma = \underbrace{41} \underbrace{63} \dots \underbrace{(2p+2)(2p-1)} \dots \underbrace{(n-1)(n-4)}(n-2)n2$$

We define the main substitution point (resp. auxiliary substitution point) of σ as the point of coordinates $(n-2, n-2)$ (resp. $(n-1, n)$) in the graphical representation of σ , and the outer point of σ as the point of coordinates $(n, 2)$ in the graphical representation of σ .

The seven other permutations obtained by symmetry from the permutation σ above are the seven other quasi-weaving permutations of size n .

For $n = 4$ or 5 , there are two quasi-weaving permutation of size n : 2413 , 3142 , 25314 and 41352 . Each of them has four possible choices for its main and auxiliary substitution points. See Figure 6 for more details. We do not define the outer point of a quasi-weaving permutation of size less than 6.

Here are a few properties of quasi-weaving permutations:

Lemma 2.6. (i) *Every quasi-weaving permutation is a simple pin-permutation.*

- (ii) *For every quasi-weaving permutation of size at least 6, exactly one of the two diagonals has the property that every point except the outer point is at a distance of at most 3 cells from this diagonal.*

Proof. (i) Checking simplicity is done by exhaustive verification. One pin representation of a quasi-weaving permutation can be obtained starting with its main substitution point, then reading the auxiliary substitution point, and proceeding through the quasi-weaving permutation using separating pins at any step, to finish with the outer point, when defined.

(ii) On the quasi-weaving permutations σ of size n given in Definition 2.14, we can check that the difference between i and σ_i , for each $i \in [1..n]$, is less than or equal to 3, except for the outer point. This proves that the main diagonal satisfies the claim. It is also clear that the other diagonal does not satisfy it. For every other quasi-weaving permutation, we conclude with symmetry arguments. \square

Point (ii) of Lemma 2.6 allows us to define the direction of a quasi-weaving permutation.

Figure 6 The graphical representations of the quasi-weaving permutations of size 4, 5 and 6. The points marked M , A (or A^+ or A^- , see p.18 for the notations) and O represent respectively the main substitution point, the auxiliary substitution point, and the outer point (when defined) of each quasi-weaving permutation..

Size	quasi-weaving permutations
4	
5	
6	

Definition 2.15. A quasi-weaving permutation of size $n \geq 6$ is said to be ascending when every point of its graphical representation (except the outer point) is at a distance of at most 3 cells from the main diagonal. Otherwise, the other diagonal verifies this property, and the quasi-weaving permutation is said to be descending.

We can notice that the direction of the diagonal in point (ii) of Lemma 2.6 is the same direction that is defined by the alignment of M and A , the main and auxiliary substitution points of the quasi-weaving permutation. Therefore, we can reformulate Definition 2.15 into Definition 2.16, generalizing it to quasi-weaving permutations of size 4 and 5. Recall that, from Definition 2.14, there are four possible choices for the main and auxiliary substitution points when the size of the quasi-weaving permutation is 4 or 5.

Definition 2.16. A quasi-weaving permutation together with a choice of the main and auxiliary substitution points is said to be ascending (resp. descending) when these points form an occurrence of the pattern 12 (resp. 21) (see Figure 5).

3 Characterization of the decomposition tree

Permutations are in one-to-one correspondence with decomposition trees. In this section we give some necessary and sufficient conditions on a decomposition tree for it to be associated with a pin-permutation through this correspondence.

Theorem 3.1. *A permutation σ is a pin-permutation if and only if its substitution decomposition tree T_σ satisfies the following conditions:*

- (C₁) *any linear node labeled by \oplus (resp. \ominus) in T_σ has at most one child that is not an ascending (resp. descending) weaving permutation.*
- (C₂) *any prime node in T_σ is labeled by a simple pin-permutation α and satisfies one of the following properties:*
 - *it has at most one child that is not reduced to a one-point permutation; moreover the point of α corresponding to the non-trivial child (if it exists) is an active point of α .*
 - *α is an ascending (resp. descending) quasi-weaving permutation, and the node has exactly two children that are not reduced to a one-point permutation: one of them expands the main substitution point of α and the other one is the permutation 12 (resp. 21), expanding the auxiliary substitution point of α .*

3.1 Preliminary remarks

Let σ be a pin-permutation. Then σ has pin representations, but not every point of σ can be the starting point for such a representation. Therefore we define:

Definition 3.1. *An active point of a pin-permutation σ is a point that is the starting point of some pin representation of σ .*

We now recall some basic properties of the set of pin-permutations.

Lemma 3.1 ([18]). *The set of pin-permutations is a class of permutations. Moreover, if p is a pin representation for some permutation σ , then for any $\pi \prec \sigma$, a pin permutation for π can be extracted from p , by keeping the points p_i that form an occurrence of π in σ .*

Instead of random patterns of a pin-permutation σ , we will often be interested in patterns defined by blocks of σ and state a restriction of Lemma 3.1 to this case:

Consequence 3.1. *If σ is a pin-permutation, then the permutation associated to every block of σ is also a pin-permutation.*

Notice the following fact used many times in the next proofs:

Fact 3.1. *Consider a pin-permutation σ whose substitution decomposition tree has a root V , and B the block of σ corresponding to a given child of V . If a pin representation of σ satisfies that there exists indices $i < j < k$ with $p_i \in B$, $p_j \in B$, and p_k is a pin separating p_i from p_j , then p_k also belongs to B .*

Assume σ is a pin-permutation and consider nodes in the substitution decomposition tree T_σ of σ . They are roots of subtrees of T_σ corresponding to permutations that are blocks of σ , and that are consequently pin-permutations. As a consequence, for finding properties of the *nodes* in the substitution decomposition tree of a pin-permutation, it is sufficient to study the properties of the *roots* of the substitution decomposition trees of pin-permutations. Before attacking this problem, we introduce two definitions useful to describe the behavior of a pin representation of σ on the children of the root of T_σ .

Definition 3.2. *Let σ be a pin-permutation and $p = (p_1, \dots, p_n)$ be a pin representation of σ . For any set B of points of σ , if k is the number of maximal factors $p_i, p_{i+1}, \dots, p_{i+j}$ of p that contain only points of B , we say that B is read in k times by p .*

Mostly, we use Definition 3.2 on sets B 's that are blocks of σ , and even more precisely children of the root of the substitution decomposition tree of σ .

Consider a pin-permutation σ whose substitution decomposition tree has a root V , and let $p = (p_1, \dots, p_n)$ be a pin representation of σ . We say that some child B of V is *the k -th child to be read by p* if, letting i be the minimal index such that p_i belongs to B , the points p_1, \dots, p_{i-1} belong to exactly $k - 1$ different children of V .

3.2 Properties of linear nodes

We analyse first the structure of pin representations of any pin-permutation σ whose substitution decomposition tree has a root that is a linear node V . We prove in Lemma 3.2 that some of these pin representations have a *child by child* way of reading σ . This will allow us to have a precise description of the children of V in Lemma 3.3.

Lemma 3.2. *If σ is a pin-permutation whose substitution decomposition tree has a root that is a linear node V , then there exists a pin representation of σ that reads every child of V in one time.*

Proof. Assume that the node V has label \oplus , the other case being similar. Let T_1, \dots, T_k be the children of V , from left to right. Since σ is a pin-permutation, there exists a pin representation p of σ . Let i_0 be the index of the child T_{i_0} to which belongs the first point of p . Assume that p is reading both T_i and T_j (with $i < j$), that is to say, that p has read some but not all points in both T_i and T_j . Consider the bounding box \mathcal{B} of the points already read by p : any child T_ℓ of V is completely included in \mathcal{B} if $i < \ell < j$, or completely outside \mathcal{B} if $\ell < i$ or $\ell > j$. Consequently, p has already completed the reading of the T_ℓ for $i < \ell < j$, and has not started the reading of the T_ℓ for $\ell < i$ or $\ell > j$. Consequently, from the pin representation p of σ , we can extract as described in Lemma 3.1 (see p.12):

- a pin representation q^{i_0} of T_{i_0} ,
- for any $i < i_0$ (resp. $i > i_0$), a pin representation q^i of T_i whose first point corresponds to a pin satisfying in p the independence condition and which is in the bottom left (resp. top right) hand corner of the bounding box of the points already read by p , which contains at least one point in T_{i_0} , and all the points in T_ℓ for $i < \ell < i_0$ (resp. $i_0 < \ell < i$).

It is now easy to check that $q = q^{i_0} q^{i_0-1} \dots q^1 q^{i_0+1} \dots q^k$ is a pin representation for σ , and that it reads every child of V in one time. \square

Lemma 3.3. *Let σ be a pin-permutation whose substitution decomposition tree has a root that is a linear node V labeled by \oplus (resp. by \ominus). Then at most one child of V is not reduced to an ascending (resp. descending) weaving permutation.*

Proof. Assume that the node V has label \oplus , the other case being similar. Let T_1, \dots, T_k be the children of V , from left to right. By Lemma 3.2, there exists a pin representation p of σ that reads the children of V one at a time. Denote by T_{i_0} the first child that is read by p . Suppose some child T_ℓ (for $\ell \geq i_0$) has just been read by p . Then the points of $T_{\ell+1}$ are in the top right hand corner with respect to the points that have already been read by p (that are all the children $T_m, \dots, T_{i_0}, \dots, T_\ell$ of V for some $m \leq i_0$, because p reads every child of V in one time). Therefore, they correspond to pins that are encoded by a symbol 1, U or R in a pin word. Furthermore, the only point that is encoded by the symbol 1 is the first point of $T_{\ell+1}$ that is read by p . Indeed, any other symbol 1 would signify that p starts the reading of the following child $T_{\ell+2}$. Consequently, $T_{\ell+1}$ is a permutation represented by a pin word of the form either $1URURUR \dots$ or $1RURURUR \dots$, that is to say, $T_{\ell+1}$ is an ascending weaving permutation. In the same way, we can prove that any $T_{\ell-1}$ with $\ell \leq i_0$ is a permutation encoded by a pin word of the form either $3LDLDDLDD \dots$ or $3DLDDLDDL \dots$, or in other words, that $T_{\ell-1}$ is again an ascending weaving permutation. As a conclusion, the only child of V that might not be an ascending weaving permutation is the first child that is read by a pin representation of σ . \square

3.3 Properties of prime nodes

We will often use Fact 2.1 (p.4) in the proofs of this subsection. A formulation of this fact in terms of substitution decomposition trees is:

Fact 3.2. *Consider a permutation σ whose substitution decomposition tree has a root V that is a prime node. There is no block in σ that intersects several children of V , except σ itself.*

We start with proving a technical lemma:

Lemma 3.4. *Let σ be a pin-permutation whose substitution decomposition tree has a prime node V as root, and let $p = (p_1, \dots, p_n)$ be a pin representation of σ . If a pin p_i that satisfies the externality and independence conditions is the first point of a child B of V to be read by p , then B is either the first or the second child of V that is read by p .*

Proof. Assume that B is a child of V that is not the first neither the second to be read by p , and denote by p_i the first point of B that is read by p . Proving that p_i satisfies the separation condition (and therefore does not satisfy the independence condition) will give the announced result. Denote by C the child of V that is read (maybe not entirely) by p just before B , and D the child of V that is read by p just before C . Since B is at least the third child of V that is read by p , C and D are well defined. Now, if p_i satisfied the externality and independence conditions, $\{p_1, \dots, p_{i-1}\}$ would form a block in σ intersecting more than one child of V (at least children C and D) but not all of them (not B), and so contradicting Fact 3.2 and concluding the proof. \square

Consider a pin-permutation σ whose substitution decomposition tree has a root V that is a prime node. Unlike linear nodes, there does not always exist a pin representation of σ that reads every child of V in one time. (consider by example the permutation $\sigma = 541263$)

However, the situations in which a child of a prime node V can be read in more than one time are very restricted. Lemma 3.5 and Consequence 3.2 are dedicated to these cases.

Lemma 3.5. *Let σ be a pin-permutation whose substitution decomposition tree with a prime node V as root and a pin representation $p = (p_1, \dots, p_n)$ of σ . If there is a child B of V that p reads in more than one time, then the second part of B read by p is reduced to p_n .*

Proof. We write the pin representation p as $p = (p_1, \dots, p_i, \dots, p_j, p_{j+1}, \dots, p_k, \dots, p_n)$ where p_i is the first point of B that is read by p , all the pins from p_i to p_j are points of B , p_{j+1} does not belong to B , and p_k is the first point belonging to B after p_{j+1} . These points are well-defined since B is read by p in more than one time. To obtain the announced result, we only need to prove that $k = n$.

For $k \leq h \leq n$, p_h satisfies the externality and separation conditions. Otherwise p_h would satisfy the externality and independence conditions and we would have a block p_1, \dots, p_{k-1} in σ intersecting more than one child of V (namely B and the block p_{j+1} belongs to), contradicting Fact 3.2 since V is prime. Moreover we can prove inductively that $p_h \in B$ for $k \leq h \leq n$. This is already done for $h = k$. Consider $h \in \{k+1, \dots, n\}$. By induction hypothesis, p_{h-1} belongs to B . As p_h satisfies the separation condition, it separates p_{h-1} from $\{p_i, \dots, p_j\} \subset \{p_1, \dots, p_{h-2}\}$ and therefore belongs to B from Fact 3.1 (p.12). As a conclusion, all points p_k, p_{k+1}, \dots, p_n are points of B .

Moreover at most one child of V is discovered before p_i . Indeed it is the case when $i \leq 2$ and when $i \geq 3$, we prove that p_i is a pin satisfying the externality and independence conditions. Otherwise since p_i is the first point of B that is read, all the points of B would be (like p_i) on the sides of the (non-trivial) bounding box of $\{p_1, \dots, p_{i-1}\}$, contradicting Lemma 2.1. We conclude with Lemma 3.4 that at most one child of V appears before B . Consequently since any simple permutation is of length at least 4 (see p.3) and p can be decomposed as $p = (\underbrace{p_1, \dots, p_{i-1}}_{\text{at most one child}}, \underbrace{p_i, \dots, p_j}_{\in B}, \underbrace{p_{j+1}, \dots, p_{k-1}}_{\notin B}, \underbrace{p_k, \dots, p_n}_{\in B})$, there are, among

p_{j+1}, \dots, p_{k-1} , points belonging to at least two different children of V , both different from B . Let us denote by C the child of V p_{k-1} belongs to, and by D another child of V that appears in p_{j+1}, \dots, p_{k-1} . As p_k separates p_{k-1} from the previous pins, and as it belongs to B , B (through p_k) separates C (to which p_{k-1} belongs) from D (to which some other pin before p_{k-1} belongs). But then any point of B that has not yet been read, namely any point of $\{p_k, \dots, p_n\}$, is on the sides of the bounding box of $\{p_1, \dots, p_{k-1}\}$. Since from Lemma 2.1 (p. 7) there is at most one point on the sides of this bounding box, we conclude that $k = n$. \square

Consequence 3.2. (i) *If some child of a prime node is read in more than one time by a pin representation p , then it is read in exactly two times, the second part being reduced to the last point of p .*

(ii) *At most one of the children of a prime node can be read in two times by a pin representation.*

At that point, given a pin-permutation σ whose substitution decomposition tree T_σ has a prime root, we know how a pin representation of σ proceeds through the children of this root. In Lemma 3.6 and Consequence 3.3, we tackle the problem of characterizing those children more precisely.

Lemma 3.6. *Let σ be a pin-permutation whose substitution decomposition tree has a prime root V and $p = (p_1, \dots, p_n)$ be a pin representation of σ . Suppose there exists a child B of V which is not reduced to a one-point permutation, and such that B is not the first child of V to be read by p . Then B is a two-point permutation, which is read in two times by p , whose pin reading the first point of B satisfies the externality and independence conditions.*

Proof. In the pin representation p of σ , we denote by p_i the first point of B that is read by p . By hypothesis, $i \geq 2$ and $i \neq n$.

Suppose that p_i satisfies the externality and separation conditions. Then necessarily, $i \geq 3$ (it is impossible for p_i to separate a set of less than 2 points), and p_i is on the sides of the bounding box of $\{p_1, \dots, p_{i-1}\}$. But since p_i is the first point of B that is read, any point of B is also on the sides of this bounding box. With Lemma 2.1, this contradicts that B is not reduced to a one-point permutation. Consequently, p_i satisfies the externality and independence conditions. By Lemma 3.4, and since we assumed it is not the first, B is the second child of V to be read by p . Let us denote by C the first child of V that is read by p . Because V is prime, there must be a point in σ , belonging to another child D of V , that separates child B from child C of V . This point separates in particular p_i from p_1 , and it is necessarily p_{i+1} , since no pin after p_{i+1} can separate p_1 from p_i . This proves that $p_{i+1} \notin B$. With Consequence 3.2(i), we get that either $B = \{p_i\}$ or $B = \{p_i, p_n\}$. Because B is not a one-point permutation, the latter holds, concluding the proof. \square

With Lemma 3.4 and Consequence 3.2, we can deduce from Lemma 3.6 that the first child of V is read by p in one time, that B is the second child to be read by p , and that p_n is the second point of B .

Consequence 3.3. *A prime node has at most two children that are not reduced to one-point permutations. Moreover, if a prime node has exactly two non-trivial children, then every pin representation of the associated pin-permutation starts with reading one of those two children entirely, and the other non-trivial child is characterized in Lemma 3.6.*

3.4 Proof of Theorem 3.1: necessary condition

With the previous technical lemmas, we prove in this section that conditions (C_1) and (C_2) of Theorem 3.1 (p.12) are necessary conditions on the substitution decomposition tree T_σ of σ for σ to be a pin-permutation.

Let σ be a pin-permutation whose substitution decomposition tree is T_σ . Any node V in T_σ is the root of some subtree T of T_σ . Moreover, T is the substitution decomposition tree T_π of some permutation $\pi \prec \sigma$, and π is a pin-permutation by Consequence 3.1 (p.12). Consequently, we only need to prove that:

- if V is a linear node, condition (C_1) is satisfied by the root of T_π ,
- if V is a prime node, condition (C_2) is satisfied by the root of T_π .

When V is a linear node, we conclude thanks to Lemma 3.3 (p.14).

So, let us assume that V is a prime node, labeled by a simple permutation α . With Lemma 3.1 (p.12), it is immediate to prove that the simple permutation α labelling node V is a simple pin-permutation, since it is a pattern of π . By Consequence 3.3, V has at most 2 children that are not reduced to a one-point permutation.

Assume V has exactly one child B that is not reduced to a one-point permutation, and consider a pin representation $p = (p_1, \dots, p_n)$ of π . We need to prove that this child expands an active point of α . If p starts with reading B (even if not entirely), then there is an occurrence of α in π in which B is represented by the first point p_1 of p , and by Lemma 3.1 we can extract from p a pin representation for α whose first point, active for α by Definition 3.1, is the one representing B . When p does not start with reading B , we apply Lemma 3.6: B contains exactly two points, the first one read in p is p_2 (read just after the first child read by p , which is a one-point permutation – hence reduced to p_1 – by hypothesis) and the second one is p_n . Observing that the first two points in a pin representation play symmetric roles, it does not matter in which order there are taken: a consequence is that $p_2, p_1, p_3, \dots, p_n$ is another admissible pin representation for π and an occurrence of α in π is composed of all points of p except p_n . Therefore $p_2, p_1, p_3, \dots, p_{n-1}$ is a pin representation for α in which B is represented by p_2 and thus B expands an active point of α .

Let us now assume that node V has exactly two children that are not reduced to one-point permutations. Consequence 3.3 shows that any pin representation $p = \{p_1, \dots, p_n\}$ of π is composed as follows:

- p reads entirely one of the non-trivial children of V denoted by C , the other one denoted by B being reduced to two points,
- the first point of B read by p satisfies the externality and independence conditions,
- the second and last point of B read by p is p_n .

Without loss of generality (that is to say up to symmetry), we can assume that B is in the top right hand corner with respect to C . This situation is represented on Figure 7.

Figure 7 Permutation π around its two non-trivial children B and C .

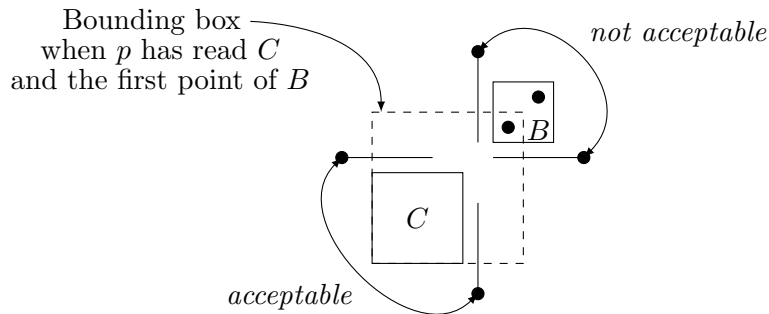

If the block B contains the permutation 21, then the second point of B would be on the sides of the bounding box when p has read C and the first point of B , and by Lemma 2.1 (p.7) this second point of B would have to be read just after the first one contradicting the primality of V (since a prime node has at least 4 children). Consequently, B contains the permutation 12.

Between the two points of B , p reads all the points of π that correspond to trivial children of V . Because V is prime, from Fact 3.2 (p.14) all of these points are pins satisfying the externality and separation conditions and there are at least two of them. There are four

possible positions for the first such pin that is read by p , but only two of them are acceptable since we need α to be simple. Indeed, choosing the up or right pin on Figure 7 (pins that are indicated as *not acceptable*) would imply that the second point of B is on the sides of the bounding box, so it has to be taken now, and since it is the last point of p , the pin representation stops, contradicting as before the primality of V . Therefore we can assume that the first pin after the first point of B is the one in the top left hand corner of C , the other possible one leading to a symmetric configuration. The pin representation is then an alternation of down and left pins, until p_{n-1} which is an up or right pin.

Consequently there is only one possible way of putting the pins corresponding to the trivial children of V that does not contradict that α is simple, nor that B contains two points. This only possible configuration is represented on Figure 8, and it corresponds to the case in which α is a quasi-weaving permutation, with C expanding its main substitution point, and B expanding its auxiliary substitution point. Moreover, when the size of α is at least 6, if the quasi-weaving permutation is ascending (resp. descending), then B contains the permutation 12 (resp. 21). The reason is that the direction defined by the alignment of blocks B and C is the same as the direction of the quasi-weaving permutation.

Figure 8 The only configuration (up to symmetry) of a pin-permutation whose root is a prime node (of arity at least 6) with two non trivial children.

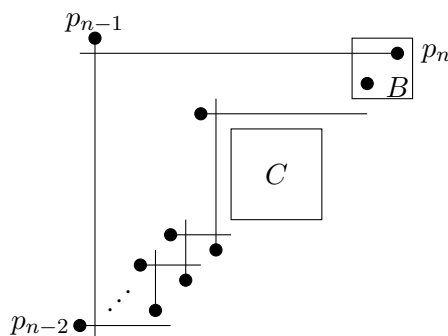

Notice that in the case of a quasi-weaving permutation of size 4 or 5, with fixed main and auxiliary substitution points, the content of the block B is also determined, again by the direction defined by the alignment of the two blocks B and C . On Figure 6 (p.11), the auxiliary substitution points written A^+ (resp. A^-) are the ones that can be substituted with 12 (resp. 21) in this context. We omit the proof, which is done by simple examination of each of the 16 cases.

This concludes the proof that conditions (C_1) and (C_2) are necessary conditions on a permutation σ for σ to be a pin-permutation..

3.5 Proof of Theorem 3.1: sufficient condition

We can now end the proof of Theorem 3.1 by proving that conditions (C_1) and (C_2) are sufficient for a permutation σ to be a pin-permutation. In the following we prove by induction on the size of σ that a permutation satisfying conditions (C_1) and (C_2) is a pin-permutation. Remind that T_σ denotes the substitution decomposition tree of σ . Notice that for $\sigma = 1$, conditions (C_1) and (C_2) are vacuously true. The pin representation with only one pin is a

pin representation for σ . Assume now that $|\sigma| > 1$, and that any permutation π such that $|\pi| < |\sigma|$ satisfying conditions (C_1) and (C_2) is a pin-permutation. We distinguish two cases, according to the type (linear or prime) of the root of T_σ .

When the root of T_σ is a linear node, consider $\sigma = \oplus[\sigma^1, \sigma^2, \dots, \sigma^k]$, without loss of generality, and assume that σ satisfies (C_1) and (C_2) . Since the decomposition trees of the $(\sigma^i)_{1 \leq i \leq k}$ are subtrees of T_σ , we get that the $(\sigma^i)_{1 \leq i \leq k}$ also satisfy conditions (C_1) and (C_2) . We can use the induction hypothesis on the $(\sigma^i)_{1 \leq i \leq k}$, and obtain that they are all pin-permutations. Moreover, condition (C_1) holds for the root of T_σ , and we deduce that at most one of the $(\sigma^i)_{1 \leq i \leq k}$ is not an ascending weaving permutation. We define i_0 as the index such that σ^{i_0} is not an ascending weaving permutation, if it exists. Otherwise, we can pick any integer $i_0 \in [1..k]$. Since σ^{i_0} is a pin-permutation, it admits a pin representation p^{i_0} . By Lemma 2.5 (p.9), for any $i < i_0$ (resp. any $i > i_0$), there exist pin representations p^i of σ^i (which is an ascending weaving permutation) whose origin is in the top right hand corner (resp. in the bottom left hand corner). Now $p = p^{i_0} p^{i_0-1} \dots p^1 p^{i_0+1} \dots p^k$ is a pin representation for σ , proving that σ is a pin-permutation. We can remark that many other pin representations p for σ could have been defined from the $(p^i)_{1 \leq i \leq k}$. Namely, $p = p^{i_0} w$ with w any shuffle of $p^{i_0-1} \dots p^1$ and $p^{i_0+1} \dots p^k$ is suitable.

When the root of T_σ is a prime node, consider $\sigma = \alpha[\sigma^1, \sigma^2, \dots, \sigma^k]$ for a simple permutation α , and assume that σ satisfies (C_1) and (C_2) . As before, by induction hypothesis, the $(\sigma^i)_{1 \leq i \leq k}$ are all pin-permutations. We denote by p^i a pin representation of σ^i . Recall that every permutation σ^i expands the point α_i of α . Applying condition (C_2) to the root of T_σ , we also get that α is a pin-permutation. By condition (C_2) , at most two permutations among $\sigma^1, \sigma^2, \dots, \sigma^k$ are not reduced to 1.

When all permutations $\sigma^1, \sigma^2, \dots, \sigma^k$ are trivial, then $\sigma = \alpha$, implying that σ is a pin-permutation. When σ^i is the only permutation that is not reduced to 1, then by condition (C_2) σ^i expands an active point of α . Thus, there exists a pin representation p of α with $p_1 = \alpha_i$. To get a pin representation for σ , we replace p_1 in p with the pin representation p^i of σ^i . By exhibiting a pin representation for σ , we proved that σ is a pin-permutation.

When two permutations among $\sigma^1, \sigma^2, \dots, \sigma^k$ are not trivial, then without loss of generality α is an ascending quasi-weaving permutation, and among the two children that are not reduced to 1, one (say σ^i) expands the main substitution point α_i of α and the other one (say σ^j) is the permutation 12, expanding the auxiliary substitution point α_j of α . Let p be the pin representation of α with p_1 corresponding to the main substitution point and p_2 to the auxiliary one. In order to get a pin representation for σ , we first remove the first pin of p and replace it by the pin representation p^i of σ^i . Then replace p_2 with the point of σ^j that is closest to the block σ^i . Because the two points expanding α_j follow the direction defined by the alignment of the main and auxiliary substitution points of α , we can define the notion of the point of σ^j closest to the block expanding the main substitution point of α . Proceed reading all following points in p and finally read the second point of σ^j , which separates the last point read in p (the outer point when $|\alpha| \geq 6$) from all the previous ones.

This finally gives a pin representation for σ , showing that σ is a pin-permutation and thus ending the proof that conditions (C_1) and (C_2) are sufficient for a permutation to be a pin-permutation.

In Section 5, we compute the generating function for the class of pin-permutations, proving that it is rational. The proof is based on the characterization of the decomposition trees of the pin-permutations, given in Theorem 3.1, and it uses standard tools in enumerative combinatorics [24]. However, it requires to compute as a starting point the generating function

of the *simple* pin-permutations. Section 4 is dedicated to this goal.

4 Generating function of the simple pin-permutations

We introduce some more terminology here.

Definition 4.1. A pin representation $p = (p_1, p_2, \dots, p_n)$ is said to be a simple pin representation and a pin word $w = w_1 w_2 \dots w_n$ is said to be a simple pin word if the permutation σ they encode is simple.

Notice that a *simple* pin representation is always a *proper* pin representation (see Definition 2.9). However, not every proper pin representation (or strict pin word) encodes a simple pin-permutation.

We shall be interested in characterizing the simple pin representations for enumerating them, in order to get the generating function of the simple pin-permutations. The enumeration of simple pin representations will be done in Subsection 4.2. Although there is not a one-to-one correspondence between simple pin representations and simple pin-permutations, we can compute how many simple pin representations are associated with a single simple pin-permutation. This will allow us to derive the enumeration of simple pin-permutations from the one of simple pin representations in Subsection 4.3.

Before this, we start with important properties of the first two points of every proper pin representation. This is presented in Subsection 4.1, together with relations between strict pin words and proper pin sequences (see Definitions 2.9 and 2.11).

4.1 Possible starts of a pin representation of a simple pin-permutation

Definition 4.2. Consider a permutation σ given by its graphical representation. We say that two points x and y of σ are (or that the pair of points (x, y) is) in knight position when the distance between the points x and y is exactly 3 cells and the two points are neither on the same row nor on the same column (see Figure 9).

Figure 9 Knight position between two points.

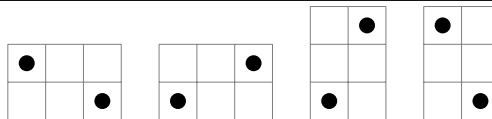

Lemma 4.1. Let $p = (p_1, p_2, \dots, p_n)$ denote a proper pin representation of some permutation σ . If $|\sigma| > 2$ the first two pins p_1, p_2 are in knight position.

Proof. By definition of proper pin representations, and since $|\sigma| > 2$, p_3 separates p_2 from p_1 , and no other future pin separates p_2 from p_1 . Thus p_1 and p_2 can only be separated by p_3 . This proves that p_1 and p_2 are in knight position. \square

Lemma 4.2. Let σ be a simple pin-permutation and $p = (p_1, p_2, \dots, p_n)$ be one of its simple pin representations. If two points p_i and p_j of σ are in knight position then i or j is equal to 1, 2 or n .

Proof. First recall that, by Fact 3.2 (p.14) as σ is simple, every pin p_i ($i \geq 3$) separates p_{i-1} from $\{p_1, \dots, p_{i-2}\}$. Consider the pin p_i . We will be looking for all the points p_j , with $j < i$, such that (p_i, p_j) are in knight position in σ . We want to prove that for each such j , $\{i, j\} \cap \{1, 2, n\} \neq \emptyset$. Assume $i \geq 3$ and $i < n$, the claim being obviously true for $i = 1$ or 2 or n . Without loss of generality, we suppose that p_i separates the previous pins from above as shown in Figure 10 and that p_{i-1} lies on the right of p_i . The thick rectangle represents the bounding box of $\{p_1, \dots, p_{i-1}\}$.

Figure 10 Pin representations where $i < n$ in the proof of Lemma 4.2.

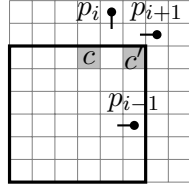

Since $i < n$, p_{i+1} separates p_i from the previous pins, from the left or the right as shown in Figure 10. Thus p_i could only be in knight position with a previous pin p_j in one of the two gray cells c and c' .

There is a pin in c' : Only p_{i-1} can be in c' and in that case it means that p_{i-1} is either p_1 or p_2 otherwise from Lemma 2.3 it could not be at a corner of the bounding box. Thus, there could be a pair of pins in knight positions between (p_1, p_2) or (p_2, p_3) .

There is a pin in c : The pin in c must be p_1 or p_2 , otherwise it would separate vertically two previous pins, one on its left and one on its right, inside the bounding box and the only pin on its right is p_{i-1} . Thus there could be a pair of pins in knight position between p_i and the pin in c , namely p_1 or p_2 .

In all cases, $\{i, j\} \cap \{1, 2, n\} \neq \emptyset$. □

Definition 4.3. An active knight in a pin-permutation σ is a pair of points (x, y) in knight position that can be the first two points of a pin representation of σ .

As a consequence of Lemma 4.1 the number of pin representations of a simple pin-permutation depends on its number of active knights.

Lemma 4.3. In any simple pin-permutation σ , there are at most two active knights except for the four permutations : 3142, 2413, 25314 and 41352 which have four active knights. The simple pin-permutations of size at most 6 and their active knights are represented on Figure 11.

For each $n > 6$, all simple pin-permutations of size n have exactly only one active knight, except twelve of them that have two active knights, and that are:

- the four weaving permutations of size n ,
- the eight quasi-weaving permutations of size n .

Proof. The results presented in Figure 11 can be obtained by exhaustive examination.

Let σ be a simple pin-permutation of size $n > 6$ and let $p = (p_1, p_2, \dots, p_n)$ be a pin representation of σ . By Lemma 4.1, the pair of points (p_1, p_2) is an active knight of σ . We

Figure 11 The simple pin-permutations of size $n \leq 6$ and their number of active knights.

n	1 active knight	2 active knights	4 active knights
4			2 4 3 1, 3 1 4 2
5		2 4 1 5 3, 3 1 5 2 4, 3 5 1 4 2, 4 2 5 1 3	2 5 3 1 4, 4 1 3 5 2
6	2 5 1 4 6 3, 2 5 3 1 6 4, 2 5 3 6 1 4, 2 6 4 1 5 3, 3 1 6 4 2 5, 3 5 1 4 6 2, 3 6 1 4 2 5, 3 6 4 1 5 2, 4 1 3 6 2 5, 4 1 6 3 5 2, 4 2 6 3 1 5, 4 6 1 3 5 2, 5 1 3 6 2 4, 5 2 4 1 6 3, 5 2 4 6 1 3, 5 2 6 3 1 4	2 4 1 6 3 5, 2 4 6 3 1 5, 2 5 1 3 6 4, 2 6 3 5 1 4, 2 6 4 1 3 5, 3 1 4 6 2 5, 3 1 5 2 6 4, 3 6 2 4 1 5, 4 1 5 3 6 2, 4 6 2 5 1 3, 4 6 3 1 5 2, 5 1 3 6 4 2, 5 1 4 2 6 3, 5 2 6 4 1 3, 5 3 1 4 6 2, 5 3 6 1 4 2	

want to prove that every permutation with at least 2 active knights is a weaving permutation or a quasi-weaving permutation. It can be easily checked that weaving permutations and quasi-weaving permutations have exactly 2 active knights. Assume σ has more than one active knight, one of them being (p_1, p_2) . By Lemma 4.2 the second active knight could be either (p_1, p_i) , (p_2, p_i) or (p_i, p_n) , for some i .

The second active knight is (p_1, p_i) . Without loss of generality, consider p_1 and p_2 in relative positions shown in Figure 12. Then there are 7 different possible positions for a point p_i to be in knight position with p_1 as shown in the figure. Positions 7 and 3 are in conflict (same row or same column) with point p_2 . A pin in position 1 creates an interval with p_2 , which is impossible since σ is simple. Thus the only remaining possible positions for p_i are 2, 4, 5 and 6.

Figure 12 Knights between (p_1, p_2) and (p_1, p_i) .

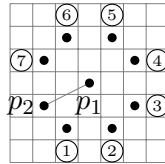

- the pin p_i is in 5: Let r be a pin representation associated with σ but which begins with (p_1, p_i) . (This pin representation exists as $(p_1, p_i) = (r_1, r_2)$ is an active knight.) Then r_3 lies on the row between r_1 and r_2 . By Lemma 2.2, r_3 is at distance 2 of the bounding box of $\{r_1, r_2\}$. It cannot lie to the left of it as it would be in the same column as p_2 . Thus r_3 is on the right side as shown in Figure 13. For the same reason p_3 lies below the bounding box of $\{p_1, p_2\}$ as shown in the first schema of Figure 13.

Then p_4 has two different possible positions. It lies in the row separating p_2 from p_3 , at distance 2 of the bounding box of $\{p_1, p_2, p_3\}$ but is either on the right or on the left of it (see Figure 13). If it lies on the right then the six points $\{p_1, p_2, p_3, p_4, p_i, r_3\}$ form a permutation of size 6, or an interval. This contradicts that σ is simple and $n > 6$. So p_4 lies on the left. Then we can build a pin representation by alternating left and down

Figure 13 Different cases for active knight (p_1, p_i) .



pins until we put a right or a up pin. It cannot be an up pin as it will not respect the distance 2 with the bounding box of the previous points (otherwise it would be in the same row as p_i). If it is a right pin, it lies in the column separating $p_i = r_2$ from r_3 and thus is r_4 . But in that case, reading the pin representation r , r_4 is not at distance 2 of the bounding box of $\{r_1, r_2, r_3\}$ contradicting Lemma 2.2.

- the pin p_i is in 4: By similar arguments, it implies that permutation is of size strictly less than 6.
- the pin p_i is in 2: p_3 lies in the column between p_1 and p_2 at distance two of the bounding box of $\{p_1, p_2\}$. It cannot lie below this bounding box as it would form an interval with p_1, p_2, p_i . Therefore it is above as shown in the second schema of Figure 13. Then there could be a pin representation made of alternating left and up pins until we have a right or down one at position k . But then, p_i separates this pin from the preceding ones and must be p_{k+1} . At that stage, $\{p_1, \dots, p_{k+1}\}$ forms an interval, and thus $i = k + 1 = n$. In that case we have a simple permutation (quasi-weaving permutation) with two active knights.
- the pin p_i is in 6: Then again σ is a quasi-weaving permutation.

The second active knight is (p_2, p_i) . Considering that $(p_2, p_1, p_3, \dots, p_n)$ is another pin representation for σ , this case has already been solved by the previous one.

The second active knight is (p_i, p_n) . Assume first that $i \geq 4$. Consider then the bounding box of $\{p_1, \dots, p_{i-2}\}$. Without loss of generality suppose that p_{i-1} is above this bounding box and that p_i is a right pin as shown in Figure 14. Notice that since p_{i-1} is an up pin,

Figure 14 Case for active knight (p_i, p_n) , $i \geq 4$.

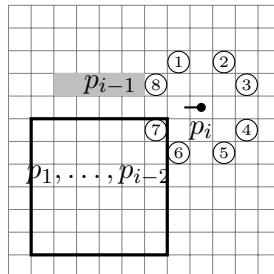

in the bounding box of $\{p_1, \dots, p_{i-2}\}$ there is a point in every row and in every column, except in the column of p_{i-1} . As p_n and p_i form an active knight, p_n must be in one of the

8 positions drawn in the figure. But positions 3, 4, 5, 6, 8 are forbidden as another point lies in the same row. Position 7 is also forbidden for p_n since it is inside the bounding box of $\{p_1, \dots, p_{i-2}\}$. If p_n is in position 2, then it means that the pin representation r , which begins the reading of σ by $r_1 = p_i, r_2 = p_n$, then proceeds with $r_3 = p_{i-1}$ and therefore p_{i-1} must lie at distance 2 of the bounding box of $\{p_i, p_n\}$ i.e. in the rightmost column of the bounding box of $\{p_1, \dots, p_{i-2}\}$ which is impossible. So that p_n is in position 1. As previously, $r_3 = p_{i-1}$. Then r_4 is a down pin, r_5 a left one, and r alternates between down and left pins. Every other direction would put the pin on the sides of the bounding box of $\{p_1, \dots, p_{i-2}\}$, contradicting Lemma 2.1. Thus σ is a weaving permutation.

Suppose now that $i < 4$: It can be proved in a similar way that there are no such permutations ($n \geq 6$). \square

A consequence of Lemma 4.3 that will be used in Subsection 4.3 is the following:

Lemma 4.4. *For any $n > 6$, there are 4 simple pin-permutations with 4 active points, 8 with 3 active points, and all others have 2 active points..*

For smaller values of n we have (see Figure 11 p.22):

- *size 4: 2 permutations with 4 active points*
- *size 5: 2 with 5 active points and 4 with 4 active points*
- *size 6: 4 with 4 active points, 12 with 3 active points, and 16 with 2 active points*

Proof. From Definitions 3.1 and 4.3, and using Lemma 4.1, we obtain easily that active points in a simple pin-permutation σ are equivalently defined as points belonging to active knights in σ . With Figure 11, we obtain the results for $n \leq 6$. For $n > 6$ it is enough to notice that the two active knights in a quasi-weaving permutation have one point in common, whereas they have no point in common in a weaving permutation. Lemma 4.3 then gives the announced result. \square

We finish this subsection by a remark that establishes a link between the numbers of simple pin representations and of simple pin-permutations.

Fact 4.1. *Given a simple pin-permutation σ with one active knight marked, then there is a unique pin representation p (up to exchanging p_1 and p_2) that reads σ starting with the marked active knight.*

In Subsection 4.3, this fact will be used to obtain the enumeration of simple pin-permutations, from the enumeration of simple pin representations.

4.2 Enumeration of simple pin representations

As noticed before (see p.20), not all proper pin representations are simple. In [16], Theorem 3.4 states (with our terminology) that every proper pin representation *nearly is* a simple pin representation, that is to say, for each proper pin representation $p = (p_1, p_2, \dots, p_n)$, either p , (p_2, p_3, \dots, p_n) or (p_1, p_3, \dots, p_n) is a simple pin representation. Refining the proof of this theorem, we show that *nearly all* proper pin representations are simple, and exhibit the ones that are not, which is a slightly different point of view.

We also noticed that for any proper pin representation $p = (p_1, p_2, p_3, \dots, p_n)$, then $p^\sim = (p_2, p_1, p_3, \dots, p_n)$ is also a proper pin representation. But those two objects represent the exact same thing: we choose first the set of points $\{p_1, p_2\}$, and then a pin p_3 that separates p_1 and p_2 , and proceed with separating pins at any step. That is why in the enumeration, we count the two pin representations p and p^\sim as **one unique object**.

For the goal of enumeration pursued here, we sometimes use simple pin words instead of simple pin representation. Lemma 4.5 shows that it is equivalent, up to a multiplicative factor of 4. In Theorem 4.1 we count the proper pin representations that are not simple. Then we easily get the enumeration of simple pin representations given in Theorem 4.2.

Lemma 4.5. *For any proper pin representation p of size at least 3, there are exactly 4 strict pin words that encode p (regardless of the order of p_1 and p_2). Those 4 strict pin words correspond to 4 possible readings of the active knight $\{p_1, p_2\}$.*

Proof. There are 12 different possible positions for the origin (p_0) but only 4 among these positions lead to a strict pin word. \square

Lemma 4.6. *For any $n \geq 3$ there are 2^n proper pin representations of size n .*

Proof. We prove that there are 2^{n+2} strict pin words of size n , Lemma 4.5 then giving the desired result immediately. There are 4 possibilities for the first letter of a strict pin word (1, 2, 3, 4), then again 4 for the second letter (U, D, L, R), and starting from the third letter only two possibilities, depending on the letter just before (only U and D can follow L or R , and conversely). This gives 2^{n+2} strict pin words of size n and concludes the proof. \square

The proof of Theorem 4.1 follows the structure of the proof of Theorem 3.4 in [16]. Lemma 4.7 is proved in this paper (as Lemma 3.3).

Lemma 4.7. *In a proper pin representation $p = (p_1, p_2, \dots, p_n)$, for any $i \geq 3$, p_i and p_{i+1} are separated either by p_{i-1} or by each of p_1, \dots, p_{i-2} .*

Theorem 4.1. *For any $n \geq 5$ there are 16 proper pin representations that are not simple. The corresponding permutations are:*

- the 8 quasi-weaving permutations with the auxiliary substitution point expanded by 12 or 21 (depending whether the quasi-weaving permutation is ascending or descending),
- 8 permutations obtained from the 4 weaving permutations by adding one element in their diagram, in one of the two corners defining the diagonal which is the direction of the weaving permutation.

For $n = 4$, only 8 proper pin representations are not simple. They correspond to the 8 permutations of the second item above.

Figure 15 gives a graphical view of the proper pin representations that are not simple.

Proof. Consider $p = (p_1, \dots, p_n)$ (with $n \geq 4$) a proper pin representation encoding a permutation σ . Assume that σ is not simple. Then there exists a non-trivial interval in σ . We choose such an interval $M \subset \{p_1, \dots, p_n\}$, with the additional property that M is minimal (it does not contain any intervals except the singletons). M containing at least two points, we

Figure 15 The two kinds of permutations that are not simple, but can be read by proper pin representations.

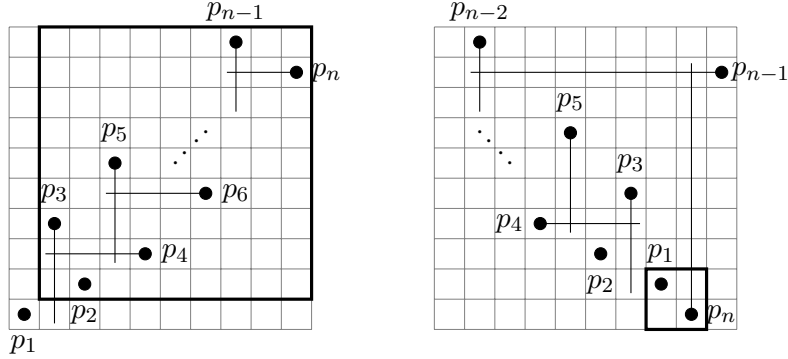

can pick i and j , with $i < j$ such that $\{p_i, p_j\} \subseteq M$. We choose j minimal among all possible values.

If $i < j < n$, then $\{p_{j+1}, \dots, p_n\} \subset M$, since all these pins separate two points belonging to M . With Lemma 4.7, since j is minimal, we get that $\{p_1, \dots, p_{j-2}\} \subset M$, unless $i = j - 1$. In this latter case, Lemma 4.7 and the minimality of j imply that $i \leq 2$, and we will consider this case later. We focus on the former case where $\{p_1, \dots, p_{j-2}\} \subset M$. If $j \geq 4$, p_{j-1} separates two points of M , so that it belongs to M also, and we get $M = \{p_1, p_2, \dots, p_n\}$, which is a contradiction (M describes a simple permutation whereas σ is not simple). If $j \leq 2$, we get the same contradiction: $M = \{p_1, p_2, \dots, p_n\}$. If $j = 3$, we assume without loss of generality that $i = 2$ and $p_1 \notin M$. All pins starting from p_4 separate two points of M so that they belong to M . But because $p_1 \notin M$ for no k must p_1 be one of the sides of the bounding box of $\{p_2, \dots, p_k\}$. It forces M to represent a weaving permutation, and p_1 to be in the corner of the bounding box of M , close to where p_2 and p_3 are. This is illustrated on the first part of Figure 15.

We are left to consider the cases where $i = j - 1$ for $i = 1$ or 2 . If $i = 1$, then $\{p_1, p_2\} \subset M$, and we get inductively that for any $k \geq 3$, $p_k \in M$, as it separates two points of M . We obtain that $M = \{p_1, p_2, \dots, p_n\}$, which is a contradiction as before. If $i = 2$, then $\{p_2, p_3\} \subset M$, and we get in the same way that $\{p_2, p_3, \dots, p_n\} \subset M$. The point p_1 is not in M or we would get a contradiction. Consequently we obtain as before the situation depicted on the first schema of Figure 15: M is a weaving permutation and p_1 is in the corner of M , close to p_2 and p_3 .

If on the contrary $j = n$, then by minimality of j , $M = \{p_i, p_n\}$. In the case $i = n - 1$, Lemma 4.7 gives a contradiction. If $3 \leq i \leq n - 2$, then p_i separates $\{p_1, \dots, p_{i-1}\}$, whereas p_n cannot, which is again a contradiction, so that $i = 1$ or 2 . Without loss of generality, assume $i = 1$, that is to say $M = \{p_1, p_n\}$. Then it is impossible that $\{p_2, p_n\}$ be also an interval: p_3 separating p_1 from p_2 must also separate p_n from p_2 . Consequently, we can suppose that $M = \{p_1, p_n\}$ is the only interval in σ or we would be done by one of the previous cases. This implies in particular that the diagram of $\{p_2, \dots, p_n\}$ represents a simple permutation, and consequently that $n \geq 5$. Without loss of generality, we can assume that p_1 and p_n are in decreasing order, from left to right, as represented on the second part of Figure 15. Then p_n can be either a right or a down pin. We will assume that it is a down pin, which is not a restriction, up to symmetry. Then it forces all pins from p_2 to p_{n-2} to be above and to the

left of p_1 , and p_{n-1} to be a right pin. Necessarily, the pins from p_3 to p_{n-2} are an alternation of left and up pins, so that σ has to be a quasi-weaving permutation where the auxiliary substitution point is expanded, by 21 on the case depicted on Figure 15. In general this point is expanded by 12 or by 21, and this is determined by the nature (ascending or descending) of the quasi-weaving permutation. \square

Theorem 4.2. *For any $n \geq 5$ there are $2^n - 16$ simple pin representations of size n , and there are 8 of size 4, none of size smaller than 4. Hence, the generating function of simple pin representations is $SiRep(z) = 8z^4 + \frac{32z^5}{1-2z} - \frac{16z^5}{1-z}$.*

Proof. The first point is an immediate consequence of Lemma 4.6 and Theorem 4.1. The second one results from elementary computations. \square

4.3 Enumeration of simple pin-permutations

Recalling that a simple pin representation corresponds to a simple pin-permutation with one marked active knight (see Fact 4.1), the enumeration given in Theorem 4.2 can also be seen as the enumeration of simple pin-permutations, in which each permutation is counted with a multiplicity equal to its number of active knights. This is not exactly this generating function that is needed for the enumeration of pin-permutation in Section 5. However, it allows us to compute the two generating functions that we will need: the generating function of the simple pin-permutations (without multiplicity), and the generating function of the simple pin-permutations with a multiplicity equal to the number of its active points.

Theorem 4.3. *The generating function of simple pin-permutations (without multiplicity) is $Si(z) = 2z^4 + 6z^5 + 32z^6 + \frac{128z^7}{1-2z} - \frac{28z^7}{1-z}$.*

Theorem 4.4. *The generating function of simple pin-permutations, with a multiplicity equal to the number of active points, is $SiMult(z) = 8z^4 + 26z^5 + 84z^6 + \frac{256z^7}{1-2z} - \frac{40z^7}{1-z}$.*

Proof. We prove here both Theorems 4.3 and 4.4. Putting Theorem 4.2 and Lemma 4.3 together, we get that:

- for $n = 4$, there are 2 simple pin-permutations, each of which have 4 active knights,
- for $n = 5$, there are 2 simple pin-permutations with 4 active knights and 4 with 2 active knights,
- for $n = 6$, there are 16 simple pin-permutations with 2 active knights and 16 with 1 active knight,
- for any $n \geq 7$, there are 12 simple pin-permutations with 2 active knights and $2^n - 16 - 2 \times 12 = 2^n - 40$ simple pin-permutations with 1 active knight.

The last point uses Fact 4.1: the 12 simple pin-permutations with 2 active knights count for a total of 2×12 simple pin representations.

We obtain

$$\begin{aligned} Si(z) &= 2z^4 + (2 + 4)z^5 + (16 + 16)z^6 + \sum_{n \geq 7} (12 + 2^n - 40)z^n \\ &= 2z^4 + 6z^5 + 32z^6 + \sum_{n \geq 7} (2^n - 28)z^n \end{aligned}$$

which finishes, after some easy computations, the proof of Theorem 4.3.

For Theorem 4.4, we need to examine the number of active points of simple pin-permutations. With Lemma 4.4, we immediately obtain

$$\begin{aligned} SiMult(z) &= (2 \times 4)z^4 + (2 \times 5 + 4 \times 4)z^5 + (4 \times 4 + 12 \times 3 + 16 \times 2)z^6 \\ &\quad + \sum_{n \geq 7} (4 \times 4 + 8 \times 3 + (2^n - 40) \times 2)z^n \\ &= 8z^4 + 26z^5 + 84z^6 + \sum_{n \geq 7} (2^{n+1} - 40)z^n \end{aligned}$$

which concludes the proof of Theorem 4.4. \square

5 Generating function of the pin-permutation class

This section is dedicated to the computation of the generating function of the pin-permutation class. Actually, we compute the generating function of the substitution decomposition trees of pin-permutations, which is equivalent from Theorem 2.2.

5.1 An equation defining the substitution decomposition trees of pin-permutations

We denote by \mathcal{S} the set of substitution decomposition trees of pin-permutations. Let us also denote by \mathcal{W}^+ (resp. \mathcal{W}^-) the set of substitution decomposition trees of ascending (resp. descending) weaving permutations, and by \mathcal{N}^+ (resp. \mathcal{N}^-) the substitution decomposition trees of pin-permutations that are not ascending (resp. descending) weaving permutations, and whose root is not \oplus (resp. \ominus). Notice that the set \mathcal{N}^+ (resp. \mathcal{N}^-) represents the trees that do not correspond to ascending (resp. descending) weaving permutations, but that can however be the children of a linear node labeled \oplus (resp. \ominus) in the substitution trees of pin-permutations.

With α (resp. β^+ , resp. β^-) being a generic notation for simple pin-permutations (resp. ascending quasi-weaving permutations, resp. descending quasi-weaving permutations), we can represent the characterization of Theorem 3.1 with the following equation:

$$\begin{aligned} \mathcal{S} = & \bullet + \begin{array}{c} \oplus \\ \diagup \quad \diagdown \\ \mathcal{W}^+ \mathcal{W}^+ \cdots \mathcal{W}^+ \end{array} + \begin{array}{c} \oplus \\ \diagup \quad \diagdown \\ \mathcal{W}^+ \cdots \mathcal{N}^+ \cdots \mathcal{W}^+ \end{array} + \begin{array}{c} \ominus \\ \diagup \quad \diagdown \\ \mathcal{W}^- \mathcal{W}^- \cdots \mathcal{W}^- \end{array} \\ & + \begin{array}{c} \ominus \\ \diagup \quad \diagdown \\ \mathcal{W}^- \cdots \mathcal{N}^- \cdots \mathcal{W}^- \end{array} + \begin{array}{c} \alpha \\ \diagup \quad \diagdown \\ \bullet \quad \bullet \quad \cdots \quad \bullet \end{array} + \begin{array}{c} \alpha \\ \diagup \quad \diagdown \\ \bullet \quad \bullet \quad \cdots \quad \bullet \end{array} \\ & + \begin{array}{c} \beta^+ \\ \diagup \quad \diagdown \\ \bullet \quad \bullet \quad \cdots \quad \bullet \end{array} + \begin{array}{c} \beta^- \\ \diagup \quad \diagdown \\ \bullet \quad \bullet \quad \cdots \quad \bullet \end{array} \end{aligned}$$



We justify this equation by recalling the conditions on the substitution decomposition tree of a permutation for it to be a pin-permutation: a permutation σ is a pin-permutation if and only if its substitution decomposition tree T_σ satisfies one of the following conditions:

- T_σ is a single leaf.
- The root of T_σ is a linear node (labeled by \oplus for example) and all of its children are ascending weaving permutations.
- The root of T_σ is a linear node (labeled by \oplus for example) and all of its children are ascending weaving permutations except one which belongs to \mathcal{N}^+ .
- The case where the root of T_σ is a linear node labeled by \ominus is similar to the two previous points, with \mathcal{W}^+ , \mathcal{N}^+ and *ascending* replaced by \mathcal{W}^- , \mathcal{N}^- and *descending* respectively.
- The root of T_σ is a prime node labeled by a simple pin-permutation α and every child is reduced to a leaf.
- The root of T_σ is a prime node labeled by a simple pin-permutation α and it has exactly one child that is not reduced to a leaf, and which expands an active point (denoted by -----) of α .
- The root of T_σ is a prime node labeled by an ascending quasi-weaving permutation β^+ and it has two children not reduced to a leaf: one of them expands the main substitution point (denoted ) of β^+ and the other one is the permutation 12 expanding the auxiliary substitution point
- The case where the root of T_σ is labeled by a descending quasi-weaving permutation β^- is the same as the preceding one except for the child 12 which should be replaced by 21.

5.2 The basic generating functions involved

In the preceding decomposition, many generating functions are involved:

- \mathcal{W}^+ , \mathcal{W}^- : This represents the sets of trees associated to weaving permutations (ascending or descending). By Definition 2.12, those two have the same enumerative sequence and we will denote by $W(z)$ their common generating function. There are two different ascending (resp. descending) weaving permutations of each size except for $n = 1, 2$ where there is only one. So that: $W^+(z) = W^-(z) = W(z) = \frac{z+z^3}{1-z}$. Notice that $\mathcal{W}^+ \cap \mathcal{W}^- = \{\bullet, T_{2413}, T_{3142}\}$.

-  ,  : The corresponding generating functions denoted by $TW^+(z)$ and $TW^-(z)$ are given by: $TW^+(z) = TW^-(z) = TW(z) = \frac{(W(z))^2}{1-W(z)}$.

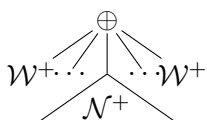
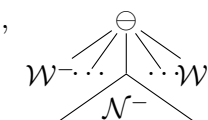
-  ,  : This represents decomposition trees that have a root labeled by \oplus (resp. \ominus), with all of its children (it has at least two children)

corresponding to ascending (resp. descending) weaving permutations, except one which belongs to \mathcal{N}^+ (resp. \mathcal{N}^-). Denoting $TWN(z)$ the generating function for sequences of ascending (resp. descending) weaving permutations, one of which is replaced by a tree of \mathcal{N}^+ (resp. \mathcal{N}^-), and $N(z)$ the one for decomposition trees in \mathcal{N}^+ (resp. \mathcal{N}^-), we obtain:

$$TWN^+(z) = TWN^-(z) = TWN(z) = \frac{2W(z) - W^2(z)}{(1 - W(z))^2} N(z)$$

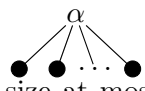
- $\mathcal{N}^+, \mathcal{N}^-$: The class \mathcal{N}^+ (resp. \mathcal{N}^-) denotes the set of substitution decomposition trees that do not correspond to ascending (resp. descending) weaving permutations and whose roots are not labeled by \oplus (resp. \ominus). From now on, we consider the case of \mathcal{N}^+ only, the case of \mathcal{N}^- being very similar. Since every weaving permutation of size at least 4 is simple, every element of size at least 4 in \mathcal{W}^+ is of the form  for

simple pin-permutations α . From Definition 2.13, the permutations of size at most 3 in \mathcal{W}^+ are 1, 21, 231 and 312, and the corresponding decomposition trees have a root labeled by \ominus , except for 1 whose tree is reduced to \bullet . Hence, the intersection of \mathcal{W}^+ with the set of trees whose root is labeled \oplus is empty. Consequently, we have:

$$\mathcal{N}^+ = \mathcal{S} - \mathcal{W}^+ - \begin{array}{c} \oplus \\ \diagup \quad \diagdown \\ \mathcal{W}^+ \quad \mathcal{W}^+ \quad \dots \quad \mathcal{W}^+ \end{array} - \begin{array}{c} \oplus \\ \diagup \quad \diagdown \\ \mathcal{W}^+ \quad \dots \quad \mathcal{N}^+ \quad \dots \quad \mathcal{W}^+ \end{array}$$

From the generating functions point of view, this gives:

$$\begin{aligned} N(z) &= N^-(z) = N^+(z) = S(z) - (W(z) + TW(z) + TWN(z)) \\ &= \frac{(z^3 + 2z - 1)(z^3 + S(z)z^3 + 2S(z)z + z - S(z))}{1 - 2z + z^2} \end{aligned}$$

- β^+, β^- : We will denote by $QW(z)$ the generating function of quasi-weaving permutations counted with a multiplicity equal to their number of substitution points pairs. By Definition 2.14, if $n \geq 6$ there are four ascending (resp. descending) quasi-weaving permutations of each size and for $n < 6$ (and of course $n \geq 4$) there are only two such permutations but with multiplicity 2, thus:

$$QW^+(z) = QW^-(z) = QW(z) = \frac{4z^4}{1 - z} \tag{1}$$

Notice also that $\{\beta^+\} \cap \{\beta^-\} = \emptyset$ if we consider as in the generating function that quasi-weaving permutations have fixed main and auxiliary substitution points.

5.3 The generating function of the class of pin-permutations

Before coming to the computation of $S(z)$ some other terms of the equation need to be explicitated.

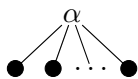
-  : These terms are enumerated by $Si(z)$ defined in Theorem 4.3.

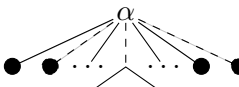
-  : The root is a prime node and one of the *active* point is non-

reduced to a leaf. Theorem 4.4 gives the generating function $SiMult(z)$ of simple pin-permutations with multiplicity equals to the number of active points. Thus the generating function for these terms is $SiMult(z)\left(\frac{S(z)-z}{z}\right)$.

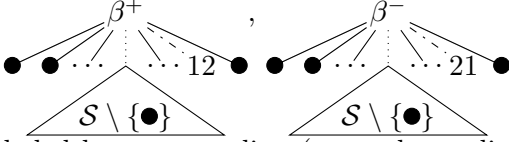
-  : For these decomposition trees, the root is labeled by an ascending (resp. descending) quasi-weaving permutation with fixed main and auxiliary substitution points (enumerated by $QW(z)$ defined in Equation 1) and such that:

- in the main substitution point, we replace the leaf by the tree of a permutation in $S \setminus \{\bullet\}$. This corresponds to the multiplication by $\frac{S(z)-z}{z}$, and
- in the auxiliary substitution point, we replace the leaf by 12 (resp. 21). It corresponds to the multiplication by z .

Thus we obtain that the generating functions for terms of the above shapes are $QW^+(z)\left(z\frac{S(z)-z}{z}\right)$ and $QW^-(z)\left(z\frac{S(z)-z}{z}\right)$.

We can finally rewrite the equation for S into an equation for the generating function $S(z)$ of pin-permutations, and we obtain:

$$\begin{aligned}
S(z) = & z + \frac{W^+(z)^2}{1 - W^+(z)} + \frac{2W^+(z) - W^+(z)^2}{(1 - W^+(z))^2}N^+(z) + \frac{W^-(z)^2}{1 - W^-(z)} + \\
& \frac{2W^-(z) - W^-(z)^2}{(1 - W^-(z))^2}N^-(z) + Si(z) + SiMult(z)\left(\frac{S(z) - z}{z}\right) \\
& + QW^+(z)\left(z\frac{S(z) - z}{z}\right) + QW^-(z)\left(z\frac{S(z) - z}{z}\right)
\end{aligned}$$

Solving this equation leads to the following result:

Theorem 5.1. *The class of pin-permutations has a rational generating function:*

$$S(z) = z \frac{8z^6 - 20z^5 - 4z^4 + 12z^3 - 9z^2 + 6z - 1}{8z^8 - 20z^7 + 8z^6 + 12z^5 - 14z^4 + 26z^3 - 19z^2 + 8z - 1}$$

The Taylor expansion of S leads to:

$$\begin{aligned}
S(z) = & z + 2z^2 + 6z^3 + 24z^4 + 120z^5 + 664z^6 + 3596z^7 + 19004z^8 \\
& + 99596z^9 + 521420z^{10} + \mathcal{O}(z^{11})
\end{aligned}$$

Notice that the eight first terms are already given in [18].

6 Infinite basis for the pin-permutation class

Let B be the basis of excluded patterns defining the pin-permutation class. This basis B is the set of minimal permutations that have no pin representation, minimal being intended in the sense of the pattern involvement relation \prec . More formally, it is equivalent to write that $B = \{\sigma : \sigma \text{ has no pin representation but } \forall \tau \prec \sigma, \tau \neq \sigma, \tau \text{ has a pin representation}\}$.

Brignall, Ruškuc and Vatter consider that "it is not even obvious that the pin-permutation class has a finite basis" [18]. Indeed, this basis B is infinite. We prove this result by exhibiting an infinite antichain $(\sigma_n)_{n \geq 8}$ in the basis of the pin-permutation class. We can notice that (σ_n) could be extended by $\sigma_6 = 361524$ and $\sigma_7 = 3746152$, but by no permutation of size 5, as shown in [18].

The study of infinite antichains of permutations has recently received much attention, see for example [4, 7, 15]. In [15], infinite antichains are obtained by adding pins around a small pattern. This technique will also apply in our case. The permutations $(\sigma_n)_{n \geq 8}$ are built inserting separating pins around the permutation $\pi = 15243$, whose graphical representation is given on Figure 16, and which has the particular following property:

Lemma 6.1. *Consider the permutation $\pi = 15243$ and let us denote by x the rightmost element in its grid representation, corresponding to 3. There is no pin representation of π that ends with x . However, every pattern of π obtained by removing an element $y \neq x$ in π has a pin representation ending with x .*

Proof. Let us denote by B the bounding box all elements of π but x . The element x divides B into two subsets of cardinality 2, so that x can satisfy neither the separation nor the independence condition with respect to B . This proves that π has no pin representation that ends with x . The second point is proved by exhaustive examination. \square

Notice also that π is a pin-permutation. Indeed, all permutations of size at most 5 are pin-permutations.

Figure 16 The permutation 15243, which is the starting point for the construction of every permutation σ_n of the infinite antichain in the basis of the pin-permutation class.

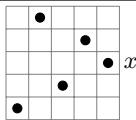

We then define the permutations $(\sigma_n)_{n \geq 8}$ around this starting point as follows:

Definition 6.1. *If $n = 2k + 1, (k \geq 4)$, then σ_n is the permutation obtained from π inserting separating pins called s_6, s_7, \dots, s_n according to the schema $(UR)^{k-3}DR$. If $n = 2k, (k \geq 4)$, then σ_n is the permutation obtained from π inserting separating pins called s_6, s_7, \dots, s_n according to the schema $(UR)^{k-4}ULU$. In both cases, the first pin separates x from the four other points in π , and every other pin separates the previous one from the other points.*

Notice that the index n corresponds to the size of σ_n and that each σ_n contains a unique occurrence of π . Some examples are given on Figure 17.

Proposition 6.1. *For any n , the permutation σ_n has no pin representation, but any permutation obtained from σ_n by removing one element is a pin-permutation.*

Figure 17 The permutations σ_n for $n = 8, 9, 10, 14$ and 15 .

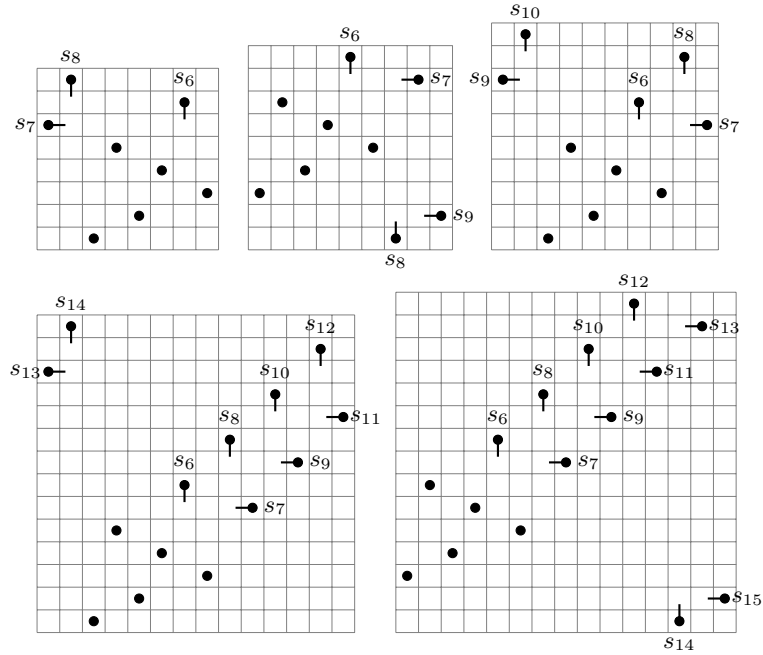

Proof. The proof is an extensive case-study using results of Lemmas 6.1 and 4.1. \square

Consequence 6.1. *The sequence (σ_n) is an antichain (for the pattern involvement relation \prec), and for any n , σ_n belongs to the basis B of excluded patterns defining the pin-permutation class.*

Proof. We prove the first point by contradiction. Assume that (σ_n) is not an antichain. Then there exist n, k , with $k < n$ such that σ_k is a pattern of σ_n . Because $k < n$, it implies that there exists a permutation τ of size $n - 1$, obtained from σ_n by removing one element, such that $\sigma_k \prec \tau \prec \sigma_n$. By Theorem 6.1, τ is a pin-permutation. With Lemma 3.1, we conclude that σ_k is also a pin-permutation, contradicting Theorem 6.1.

Theorem 6.1 implies that every strict pattern of σ_n is a pin-permutation, since the set of pin-permutations is a class of permutation (see Lemma 3.1). The second point then comes easily from the definition of the basis of a permutation class. \square

This allows us to conclude that:

Theorem 6.1. *The pin-permutation class has an infinite basis.*

Classes of permutations having both an infinite basis and a rational generating function are pretty rare in the literature. We found only one example in [1]: the classes T_k of permutations obtained after k transposition switches in series, for $k \geq 5$. We can notice that in [1] the rationality of the generating functions is obtained with automata-theoretic techniques, and this can be compared to our proof of Theorem 5.1 where the language of pin words plays a key role.

7 Conclusion and open questions

Before turning back to the original motivations of their definition, we summarize the improvements that we obtained in the study of pin-permutations. Theorem 3.1 characterizes the decomposition trees of pin-permutations, but most importantly it gives a recursive description of these permutations. Another way for enlightening structure in permutation classes is to describe their basis. For pin-permutations, although we prove that the basis is infinite, there is as far as we know no complete description of the basis.

Let us now get back to the context in which pin-permutations were originally defined. Albert and Atkinson proved in [2] that every class of permutations containing a finite number of simple permutations has an algebraic generating function. Brignall, Ruškuc, and Vatter then defined in [18] a procedure for checking this criterion automatically, that is to say, for deciding whether the number of simple permutations in a class \mathcal{C} given by its finite basis B is finite or not. In this procedure, they check three properties of the class \mathcal{C} : does \mathcal{C} contains arbitrarily long parallel alternations? wedge simple pin-permutations? proper pin-permutations? The first two points are easy: they can be reformulated into properties of the permutations in the basis B in terms of pattern-avoidance. The third point is the main step in the decision procedure, and uses finite automata techniques.

One question that remains opened is the complexity of this decision problem. Analyzing carefully the procedure of [18], we can observe that the construction of the automata that are used can be done in polynomial time, until a last step involving the determinization of a transducer. This causes an exponential blow-up in the complexity of the algorithm. A natural question is to ask if there exists a polynomial-time algorithm for deciding whether a class contains a finite number of simple permutations.

References

- [1] Michael H. Albert, Robert E.L. Aldred, Mike D. Atkinson, Hans P. van Ditmarsch, Chris C. Handley, Derek A. Hotlon, and D.J. McCaughan. Compositions of pattern restricted sets of permutations. *Australasian J. Combinatorics*, 37:43–56, 2007.
- [2] Michael H. Albert and Mike D. Atkinson. Simple permutations and pattern restricted permutations. *Discrete Mathematics*, 300(1-3):1–15, 2005.
- [3] Michael H. Albert, Mike D. Atkinson, and Martin Klazar. The enumeration of simple permutations. *Journal of Integer Sequences*, 6, 2003.
- [4] Mike D. Atkinson, M. Murphy, and Nik Ruškuc. Partially well-ordered closed sets of permutations. *Order*, 2(19):101–113, 2002.
- [5] Sèverine Bérard, Anne Bergeron, Cédric Chauve, and Christophe Paul. Perfect sorting by reversals is not always difficult. *IEEE/ACM Trans. Comput. Biol. Bioinformatics*, 4(1):4–16, 2007.
- [6] Anne Bergeron, Cédric Chauve, Fabien de Montgolfier, and Mathieu Raffinot. Computing commons interval of k permutations, with applications to modular decomposition of graphs. *SIAM J. Discrete Math.*, 22(3):1022–1039, 2008.

- [7] Miklós Bóna and Daniel A. Spielman. An infinite antichain of permutations. *Electr. J. Comb.*, 7, N2, 2000.
- [8] Prosenjit Bose, Jonathan F. Buss, and Anna Lubiw. Pattern matching for permutations. *Information Processing Letters*, 65:277–283, 1998.
- [9] Mireille Bousquet-Mélou. Four classes of pattern-avoiding permutations under one roof: Generating trees with two labels. *Electr. J. Comb.*, on(2), 2002.
- [10] Mathilde Bouvel and Elisa Pergola. Posets and permutations in the duplication-loss model: Minimal permutations with d descents. *CoRR*, abs/0806.1494, 2008.
- [11] Mathilde Bouvel and Dominique Rossin. The longest common pattern problem for two permutations. *Pure Mathematics and Applications*, 17(1-2):55–69, 2006.
- [12] Mathilde Bouvel, Dominique Rossin, and Stéphane Vialette. Longest common separable pattern among permutations. In *18th Annual Symposium Combinatorial Pattern Matching, (CPM 2007)*, volume 4580 of *Lecture Notes in Computer Science*, pages 316–327. Springer, 2007.
- [13] Andreas Brandstädt, Van Bang Le, and Jeremy P. Spinrad. *Graph classes: a survey*. Society for Industrial and Applied Mathematics, Philadelphia, PA, USA, 1999.
- [14] Robert Brignall. A survey of simple permutations. To appear.
- [15] Robert Brignall. Wreath products of permutation classes. *Electron. J. Combin.*, 14(1):Research Paper 46, 15 pp. (electronic), 2007.
- [16] Robert Brignall, Sophie Huczynska, and Vincent Vatter. Decomposing simple permutations, with enumerative consequences. *Combinatorica*, to appear.
- [17] Robert Brignall, Sophie Huczynska, and Vincent Vatter. Simple permutations and algebraic generating functions. *J. Combin. Theory Ser. A*, 115(3):423–441, 2008.
- [18] Robert Brignall, Nik Ruškuc, and Vincent Vatter. Simple permutations: decidability and unavoidable substructures. *Theoret. Comput. Sci.*, 391(1-2):150–163, 2008.
- [19] Hermann Buer and Rolf H. Möhring. A fast algorithm for the decomposition of graphs and posets. *Mathematics of Operations Research*, 8(2):170–184, May 1983.
- [20] Sylvie Corteel, Guy Louchard, and Robin Pemantle. Common intervals in permutations. *Discrete Mathematics and Theoretical Computer Science*, 8:189–214, 2006.
- [21] Alain Cournier and Michel Habib. A new linear algorithm for modular decomposition. In Sophie Tison, editor, *19th International Colloquium Trees in Algebra and Programming - CAAP'94*, volume 787 of *Lecture Notes in Computer Science*, pages 68–84. Springer, 1994.
- [22] Sinisa Crvenkovic, Igor Dolinka, and Petar Markovic. A survey of algebra of tournaments. *Novi Sad Journal of Mathematics*, 29(2):95–130, 1999.
- [23] Sergi Elizalde. *Statistics on pattern-avoiding permutations*. PhD thesis, MIT, 2004.

- [24] Philippe Flajolet and Robert Sedgewick. *Analytic Combinatorics*. Cambridge University Press, 2008.
- [25] Roland Fraïssé. On a decomposition of relations which generalizes the sum of ordering relations. *Bull. Amer. Math. Soc.*, 59:389, 1953.
- [26] Tibor Gallai. Transitiv orientierbare Graphen. *Acta Mathematica Academiae Scientiarum Hungaricae*, 18(1-2):25–66, 1967.
- [27] Steffen Heber and Jens Stoye. Finding all common intervals of k permutations. In *12th Annual Symposium Combinatorial Pattern Matching, (CPM 2001)*, volume 2089 of *Lecture Notes in Computer Science*, pages 207–218. Springer Verlag, 2001.
- [28] Louis Ibarra. Finding pattern matchings for permutations. *Information Processing Letters*, 61:293–295, 1997.
- [29] Pierre Ille. Indecomposable graphs. *Discrete Mathematics*, 173:71–78, 1997.
- [30] Sergey Kitaev and Toufik Mansour. A survey on certain pattern problems. available at <http://www.ru.is/kennarar/sergey/publications.html>, 2003.
- [31] Frederic Maffray and Myriam Preissmann. A translation of Tibor Gallai’s paper: Transitiv orientierbare Graphen. In J.L. Ramirez-Alfonsin and B.A. Reed, editors, *Perfect graphs*, pages 25–66. J. Wiley, 2001.
- [32] Adam Marcus and Gábor Tardos. Excluded permutation matrices and the Stanley-Wilf conjecture. *J. Comb. Theory, Ser. A*, 107(1):153–160, 2004.
- [33] Rolf H. Möhring and Franz J. Radermacher. Substitution decomposition for discrete structures and connections with combinatorial optimization. *Annals of Discrete Math*, 19:257–356, 1984.
- [34] James H. Schmerl and William T. Trotter. Critically indecomposable partially ordered sets, graphs, tournaments and other binary relational structures. *Discrete Mathematics*, 113:191–205, 1993.
- [35] Jeremy Spinrad. P4-trees and substitution decomposition. *Discrete Applied Mathematics*, 39(3):263–291, 1992.
- [36] David P. Sumner. *Indecomposable graphs*. PhD thesis, Univ. of Massachusetts, 1971.
- [37] Takeaki Uno and Mutsunori Yagiura. Fast algorithms to enumerate all common intervals of two permutations. *Algorithmica*, 14:209–227, 2000.
- [38] Vincent Vatter. Enumeration schemes for restricted permutations. *Comb. Probab. Comput.*, 17(1):137–159, 2008.