



HAL
open science

The speed of a biased random walk on a percolation cluster at high density

Alexander Fribergh

► **To cite this version:**

Alexander Fribergh. The speed of a biased random walk on a percolation cluster at high density. 2008. hal-00346954v1

HAL Id: hal-00346954

<https://hal.science/hal-00346954v1>

Preprint submitted on 12 Dec 2008 (v1), last revised 17 Nov 2010 (v2)

HAL is a multi-disciplinary open access archive for the deposit and dissemination of scientific research documents, whether they are published or not. The documents may come from teaching and research institutions in France or abroad, or from public or private research centers.

L'archive ouverte pluridisciplinaire **HAL**, est destinée au dépôt et à la diffusion de documents scientifiques de niveau recherche, publiés ou non, émanant des établissements d'enseignement et de recherche français ou étrangers, des laboratoires publics ou privés.

THE SPEED OF A BIASED RANDOM WALK ON A PERCOLATION CLUSTER AT HIGH DENSITY

ALEXANDER FRIBERGH

ABSTRACT. We study the speed of a biased random walk on a percolation cluster on \mathbb{Z}^d in function of the percolation parameter p . We obtain a first order expansion of the speed at $p = 1$ which proves that percolating slows down the random walk at least in the case where the drift is along a component of the lattice.

1. INTRODUCTION

Random walks in reversible random environments are an important subfields of random walks in random media. In the last few years a lot of work has been done to understand these models on \mathbb{Z}^d , one of the most challenging being the model of reversible random walks on percolation clusters, which has raised many questions.

In this model, the walker is restrained to a locally inhomogeneous graph, making it difficult to transfer any methods used for elliptic random walks in random media. In the beginning results concerned simple random walks, the question of recurrence and transience (see [13]) was first solved and latter on a quenched invariance principles was proved in [4] and [20]. More recently new results (e.g. [19] and [5]) appeared, but still under the assumption that the walker has no global drift.

The case of drifted random walks on percolation cluster features a very interesting phenomenon which was first described in the theoretical physics literature (see [8] and [9]), as the drift increases the model switches from a ballistic to a sub-ballistic regime. From a mathematical point of view, this conjecture was partially addressed in [6] and [24]. This slowdown is due to the fact that the percolation cluster contains arbitrarily large parts of the environment which act as traps for a biased random walk. This phenomenon, and more, is known to happen on inhomogeneous Galton-Watson trees, cf. [17], [3] and [2].

Nevertheless this model is still not well understood and many questions remain open, the most famous being the existence and the value of a critical

2000 *Mathematics Subject Classification.* primary 60K37; secondary 60J45, 60D05.

Key words and phrases. Random walk in random conductances, Percolation cluster, Electrical networks, Kalikow.

drift for the expected phase transition. Another question of interest is the dependence of the limiting velocity with respect to the parameters of the problem i.e. the percolation parameter and the bias. This last question is not specific to this model, but understanding in a quantitative, or even qualitative way, the behaviour of speed of random walks in random media seems to be a difficult problem and very few results are currently available on \mathbb{Z}^d (see [22]).

In this article we study the dependence of the limiting velocity with respect to the percolation parameter around $p = 1$. We try to adapt the methods used in [22] which were introduced to study environments subject to small perturbations in a uniformly-elliptic setting. For biased-random walk on a percolation cluster of high density, the walk is subject to rare but arbitrarily big perturbations so that the problem is very different and appears to be more difficult.

The methods rely mainly on a careful study of Kalikow's auxiliary random walk which is known to be linked to the random walks in random environments (see [27] and [26]) and also to the limiting velocity of such walks when it exists (see [22]). Our main task is to show that the unbounded effects of the removal of edges, once averaged over all configurations, is small. This will enable us to consider Kalikow's auxiliary random walk as a small perturbation of the biased random walk on \mathbb{Z}^d . As far as we know it is the first time such methods are used to study a random conductance model or even a non-elliptic random walks in random media.

2. THE MODEL

The models presented in [6] and [24] are slightly different, we choose to consider the second one as it is a bit more general, since it allows the drift to be in any direction. Nevertheless all the following can be adapted without any difficulty to the model described in [6].

Let us describe the environment, we consider the set of edges $E(\mathbb{Z}^d)$ of the lattice \mathbb{Z}^d for some $d \geq 2$. We fix $p \in (0, 1)$ and perform a Bernoulli bond-percolation, that is we pick a random configuration $\omega \in \Omega := \{0, 1\}^{E(\mathbb{Z}^d)}$ where each edge has probability p (resp. $1 - p$) of being open (resp. closed) independently of all other edges. Let us introduce the corresponding measure

$$\mathbf{P}_p = (p\delta_1 + (1 - p)\delta_0)^{\otimes E(\mathbb{Z}^d)}.$$

Hence an edge e will be called open (resp. closed) in the configuration ω if $\omega(e) = 1$ (resp. $\omega(e) = 0$). This naturally induces a subgraph of \mathbb{Z}^d which will be denoted ω and it also yields a partition of \mathbb{Z}^d into open clusters.

It is classical in percolation that for $p > p_c(d)$, where $p_c(d) \in (0, 1)$ denotes the critical percolation probability of \mathbb{Z}^d (see [12]), we have a unique infinite

open cluster $K_\infty(\omega)$, \mathbf{P}_p -a.s.. Moreover the following event has positive \mathbf{P}_p -probability

$$\mathcal{I} = \{\text{there is a unique infinite cluster } K_\infty(\omega) \text{ and it contains } 0\}.$$

In order to define the random walk, we introduce a bias $\ell = \lambda \vec{\ell}$ of strength $\lambda > 0$ and a direction $\vec{\ell}$ which is in the unit sphere with respect to the Euclidian metric of \mathbb{R}^d . On a configuration $\omega \in \Omega$, we consider the Markov chain of law P_x^ω on \mathbb{Z}^d with transition probabilities $p^\omega(x, y)$ for $x, y \in \mathbb{Z}^d$ defined by

- (1) $X_0 = x$, P_x^ω -a.s.,
- (2) $p^\omega(x, x) = 1$, if x has no neighbour in ω ,
- (3) $p^\omega(x, y) = \frac{c^\omega(x, y)}{\sum_{z \sim x} c^\omega(x, z)}$,

where $x \sim y$ means that x and y are adjacent in \mathbb{Z}^d and also we set

$$\text{for all } x, y \in \mathbb{Z}^d, \quad c^\omega(x, y) = \begin{cases} e^{(y+x) \cdot \ell} & \text{if } x \sim y \text{ and } \omega(\{x, y\}) = 1, \\ 0 & \text{otherwise.} \end{cases}$$

We see that this Markov chain is reversible with invariant measure given by

$$\pi^\omega(x) = \sum_{y \sim x} c^\omega(x, y).$$

Let us call $c^\omega(x, y)$ the conductance between x and y in the configuration ω , this is natural because of the links existing between reversible Markov chains and electrical networks. We will be making extensive use of this relation and we refer the reader to [10] and [16] for a further background. Moreover for an edge $e = [x, y] \in E(\mathbb{Z}^d)$, we denote $c^\omega(e) = c^\omega(x, y)$ and $r^\omega(e) = 1/c^\omega(e)$.

Finally the annealed law of the biased random walk on the infinite percolation cluster will be the semi-direct product $\mathbb{P}_p = \mathbf{P}_p[\cdot | \mathcal{I}] \times P_0^\omega[\cdot]$.

The starting point of our work is the existence of a constant limiting velocity which was proved in [24] and with some additional work Sznitman managed to obtain the following result

Theorem 2.1. *For any $d \geq 2$, $p \in (p_c(d), 1)$ and any $\ell \in \mathbb{R}_*^d$, there exists $v_\ell(p) \in \mathbb{R}^d$ such that*

$$\text{for } \omega - \mathbf{P}_p[\cdot | \mathcal{I}] - \text{a.s.}, \quad \lim_{n \rightarrow \infty} \frac{X_n}{n} = v_\ell(p), \quad P_0^\omega - \text{a.s.}$$

Moreover there exist $\lambda_1(p, d, \ell), \lambda_2(p, d, \ell) \in \mathbb{R}_+$ such that

- (1) for $\lambda = \ell \cdot \vec{\ell} < \lambda_1(p, d, \ell)$, we have $v_\ell(p) \cdot \vec{\ell} > 0$,
- (2) for $\lambda = \ell \cdot \vec{\ell} > \lambda_2(p, d, \ell)$, we have $v_\ell(p) = 0$.

Our main result is a first order expansion of the limiting velocity with respect to the percolation parameter at $p = 1$. As in [22], the result depends on certain Green functions defined for a configuration ω as

$$\text{for any } x, y \in \mathbb{Z}^d, \quad G^\omega(x, y) := E_x^\omega \left[\sum_{n \geq 0} \mathbf{1}\{X_n \in y\} \right].$$

Before stating our main theorem we recall that $v_\ell(1) = \sum_{e \in \nu} p^{\omega_0}(0, e)e$, where ω_0 is the environment at $p = 1$ and ν is the set of unit vectors of \mathbb{Z}^d .

Theorem 2.2. *For $d \geq 2$, $p \in (p_c(d), 1)$ and for any $\ell \in \mathbb{R}_*^d$, we have*

$$v_\ell(1 - \varepsilon) = v_\ell(1) - \varepsilon \sum_{e \in \nu} (v_\ell(1) \cdot e)(G^{\omega_0^e}(0, 0) - G^{\omega_0^e}(e, 0))(v_\ell(1) - d_e) + o(\varepsilon),$$

where for any $e \in \nu$ we denote

$$\text{for } f \in E(\mathbb{Z}^d), \quad \omega_0^e(f) = \mathbf{1}\{f \neq e\} \text{ and } d_e = \sum_{e' \in \nu} p^{\omega_0^e}(0, e')e',$$

are respectively the environment where only the edge $[0, e]$ is closed and its corresponding mean drift at 0.

Proposition 2.1. *Suppose that for $e \in \nu$ such that $v_\ell(1) \cdot e > 0$ we have $v_\ell(1) \cdot e \geq \|v_\ell(1)\|_2^2$ then*

$$v_\ell(1) \cdot v'_\ell(1) > 0,$$

which in words means that the percolating slows down the random walk at least at $p = 1$.

The previous condition is verified for example in the following cases

- (1) $\vec{\ell} \in \nu$, i.e. when the drift is along a component of the lattice,
- (2) $\ell = \lambda \vec{\ell}$, where $\lambda < \lambda_c(\vec{\ell})$ for some $\lambda_c(\vec{\ell}) > 0$, i.e. when the drift is weak.

Remark 2.1. *The property of Proposition 2.1 is expected to hold for any drift and this is why we chose a negative sign in front of the first order of the expansion in Theorem 2.2. But for technical reasons we were unable to carry out the computations. More generally the previous should be true in a great variety of cases, in particular one could hope it holds in the whole supercritical regime. For a somewhat related conjecture, see [7].*

Remark 2.2. *Another natural consequence which is not completely obvious to prove is that the speed is positive for p close enough to 1.*

Remark 2.3. *Finally, this result can give some insight on the dependence of the speed with respect to the bias. Indeed, fix a bias ℓ and some $\mu > 1$, Theorem 2.2 implies that for $\varepsilon_0 = \varepsilon_0(\ell, \mu) > 0$ small enough we have*

$$v_{\mu\ell}(1 - \varepsilon) > v_\ell(1 - \varepsilon) \text{ for } \varepsilon < \varepsilon_0.$$

Before turning to the proof of this result, we introduce some further notations. Let us also point out that we will refer to the percolation parameter as $1 - \varepsilon$ instead of p and assume $\varepsilon < 1/2$. In particular we have $1 - \varepsilon > p_c(d)$ for all $d \geq 2$.

We denote by $\{x \leftrightarrow y\}$ the event that x and y are connected in ω . If we want to emphasize the configuration we will use $\{x \overset{\omega}{\leftrightarrow} y\}$. Accordingly, let us denote $K^\omega(x)$ the cluster (or connected component) of x in ω .

Given a set V of vertices of \mathbb{Z}^d we denote by $|V|$ its cardinality, by $E(V) = \{[x, y] \in E(\mathbb{Z}^d) \mid x, y \in V\}$ its edges and

$$\partial V = \{x \in V \mid y \in \mathbb{Z}^d \setminus V, x \sim y\}, \quad \partial_E V = \{[x, y] \in E(\mathbb{Z}^d) \mid x \in V, y \notin V\},$$

and also for B a set of edges of $E(\mathbb{Z}^d)$ we denote

$$\partial B = \{x \mid \exists y, z, [x, y] \in B, [x, z] \notin B\}, \quad \partial_E B = \{[x, y] \mid x \in \partial B, y \notin \partial B \cup V(B)\},$$

where $V(B) = \{x \in \mathbb{Z}^d \mid \exists y \in \mathbb{Z}^d [x, y] \in B\}$.

Given a subgraph G of \mathbb{Z}^d containing all vertices of \mathbb{Z}^d , we denote $d_G(x, y)$ the graph distance in G induced by \mathbb{Z}^d between x and y , moreover if x and y are not connected in G we set $d_G(x, y) = \infty$. In particular $d_\omega(x, y)$ is the distance in the percolation cluster if $\{x \leftrightarrow y\}$. Moreover for $x \in G$ and $k \in \mathbb{N}$, we denote the ball of radius k by

$$B_G(x, k) = \{y \in G, d_G(x, y) \leq k\} \text{ and } B_G^E(x, k) = E(B_G(x, k)),$$

where we will omit the subscript when $G = \mathbb{Z}^d$.

Let us denote by $(e^{(i)})_{i=1 \dots d}$ an orthonormal basis of \mathbb{Z}^d such that $e^{(1)} \cdot \vec{\ell} \geq e^{(2)} \cdot \vec{\ell} \geq \dots \geq e^{(d)} \cdot \vec{\ell} \geq 0$, in particular we have $e^{(1)} \cdot \vec{\ell} \geq 1/\sqrt{d}$.

In order to control volume growth let us define ρ_d such that

$$\text{for all } r \geq 1, \quad |B(x, r)| \leq \rho_d r^d \text{ and } |\partial B(x, r)| \leq \rho_d r^{d-1}.$$

We will need to modify the configuration of the percolation cluster at certain vertices. So given $A_1, A_2 \in E(\mathbb{Z}^d)$, $B_1 \in \{0, 1\}^{A_1}$ and $B_2 \in \{0, 1\}^{A_2}$, let us denote $\omega_{A_2, B_2}^{A_1, B_1}$ the configuration such that

- (1) $\omega_{A_2, B_2}^{A_1, B_1}([x, y]) = \omega([x, y])$, if $[x, y] \notin A_1 \cup A_2$,
- (2) $\omega_{A_2, B_2}^{A_1, B_1}([x, y]) = \mathbf{1}\{[x, y] \notin B_1\}$, if $[x, y] \in A_1$,
- (3) $\omega_{A_2, B_2}^{A_1, B_1}([x, y]) = \mathbf{1}\{[x, y] \notin B_2\}$, if $[x, y] \in A_2 \setminus A_1$,

which in words means that we impose that the closed edges of A_1 (resp. A_2) are exactly those of B_1 (resp. B_2), and in case of an intersection between A_1 and A_2 the condition imposed by A_1 is most important. For $k_1, k_2 \geq 1$, $z_1, z_2 \in \mathbb{Z}^d$ and $B_1, B_2 \in \{0, 1\}^{B^E(z_1, k_1)} \times \{0, 1\}^{B^E(z_2, k_2)}$, we introduce

(2.1)

$$\omega_{(z_2, k_2), B_2}^{(z_1, k_1), B_1} := \omega_{B^E(z_2, k_2), B_2}^{B^E(z_1, k_1), B_1} \text{ and for } B_1, B_2 \in \{0, 1\}^\nu, \quad \omega_{z_2, B_2}^{z_1, B_1} := \omega_{(z_2, 1), z+B_2}^{(z_1, 1), z+B_1},$$

to describe configurations modified on balls. Moreover

$$(2.2) \quad \omega^{A,1} := \omega^{A,\emptyset} \text{ and } \omega^{A,0} := \omega^{A,A},$$

to denote in particular the special cases where all (resp. no) edges of A are open. We will use of combinations of these notations, for example, $\omega^{(z,k),1} := \omega^{B^E(z,k),\emptyset}$.

In connection with that, for a given configuration $\omega \in \Omega$, we call configuration of z and denote

$$\mathcal{C}(z) = \{e \in \nu, \omega([z, z+e]) = 0\},$$

the set of closed edges adjacent to z .

Hence we can denote $e \in \nu$ and $A \in \{0, 1\}^\nu$

$$(2.3) \quad p^A(e) = p^{\omega^{0,\nu \setminus A}}(0, e), \quad c(e) = c^{\omega^{0,1}}(e) \text{ and } \pi^A = \pi^{\omega^{0,\nu \setminus A}}(0).$$

Furthermore the pseudo elliptic constant $\kappa_0 = \kappa_0(\ell, d) > 0$ will denote

$$(2.4) \quad \kappa_0 = \min_{A \in \{0,1\}^\nu, e \notin A} p^A(e),$$

which is the minimal non-zero transition probability.

Similarly we fix $\kappa_1 = \kappa_1(\ell, d) > 0$ such that

$$(2.5) \quad \frac{1}{\kappa_1} \pi^{\omega^{z,A}}(z) \leq e^{2\lambda z \cdot \vec{\ell}} \leq \kappa_1 \pi^{\omega^{z,A}}(z),$$

for any $A \in \{0, 1\}^\nu \setminus \nu$ and $z \in \mathbb{Z}^d$.

Finally τ_δ will denote a geometric random variable of parameter $1 - \delta$ independent of the random walk and the environment moreover for $A \subset \mathbb{Z}^d$ set

$$T_A = \inf\{n \geq 0, X_n \in A\} \text{ and } T_A^+ = \inf\{n \geq 1, X_n \in A\},$$

and for $z \in \mathbb{Z}^d$ we denote T_z (resp. T_z^+) for $T_{\{z\}}$ (resp. $T_{\{z\}}^+$).

Concerning constants we choose to denote them by C_i for global constants, or γ_i for local constants and will implicitly be supposed to be in $(0, \infty)$. Their dependence with respect to d and ℓ will not always be specified.

Let us present the structure of the paper. In the Section 3, we will introduce the central tool for the computation of the expansion of the speed: Kalikow's environment and link it to the asymptotic speed. Then, we will concentrate on getting the continuity of the speed, mathematically the problem is simply reduced to giving upper bounds on quantities depending on Green functions, on a more heuristical level our aim is to understand the slowdown induced by unlikely configurations where "traps" appear. Since getting the upper bound is a rather complicated and technical matter we will first give a quick sketch, as soon as further notations are in place, and try to motivate our approach at the end of the next section.

In Section 4 and Section 5, we will respectively give estimates on the behaviour of the random walk near traps and on the probability of appearance of such traps in the percolation cluster. Then in Section 6 we will put together the previous results to prove the continuity of the speed.

The proof of Theorem 2.2 will be done in Section 7. In order to obtain the first order expansion, the task is essentially similar to obtaining the continuity, but the computations are much more involved and will partly be postponed to Section 8.

Finally Proposition 2.1 is proved in Section 9.

3. KALIKOW'S AUXILIARY RANDOM WALK

We denote for $x, y \in \mathbb{Z}^d$, P a Markov operator and $\delta < 1$, the Green function of the random walk killed at geometric rate $1 - \delta$ by

$$G_\delta^P(x, y) := E_x^P \left[\sum_{k=0}^{\infty} \delta^k \mathbf{1}\{X_k = y\} \right] \text{ and } G_\delta^\omega(x, y) := G_\delta^{P^\omega}(x, y),$$

where P^ω is the Markov operator associated to the random walk in the environment ω .

Then we introduce the so-called Kalikow environment associated with the point 0 and the environment $\mathbf{P}_{1-\varepsilon}[\cdot | \mathcal{I}]$, which is given for $z \in \mathbb{Z}^d$, $\delta < 1$ and $e \in \nu$ by

$$\widehat{p}_\delta^\varepsilon(z, e) = \frac{\mathbf{E}_{1-\varepsilon}[G_\delta^\omega(0, z)p^\omega(z, e)|\mathcal{I}]}{\mathbf{E}_{1-\varepsilon}[G_\delta^\omega(0, z)|\mathcal{I}]}.$$

The family $(\widehat{p}_\delta^\varepsilon(z, e))_{z \in \mathbb{Z}^d, e \in \nu}$ defines transition probabilities of a certain Markov chain on \mathbb{Z}^d . It is called Kalikow's auxiliary random walk and its first appearance in a slightly different form goes back to [14].

This walk has proved to be useful because it links the annealed expectation of a Green function of a random walk in random media to the Green function of a Markov chain. This result is summarized in the following proposition.

Proposition 3.1. *For $z \in \mathbb{Z}^d$ and $\delta < 1$, we have*

$$\mathbf{E}_{1-\varepsilon} \left[G_\delta^\omega(0, z) | \mathcal{I} \right] = G_\delta^{\widehat{p}_\delta^\varepsilon}(0, z).$$

The proof of this result can be directly adapted from the proof of Proposition 1 in [22]. We emphasize that in the case $\delta < 1$, the uniform ellipticity condition is not needed.

Using the former property we can link the Kalikow's auxiliary random walk to the speed of our RWRE through the following proposition.

Proposition 3.2. *For any $0 < \varepsilon < 1 - p_c(\mathbb{Z}^d)$, we have*

$$\lim_{\delta \rightarrow 1} \frac{\sum_{z \in \mathbb{Z}^d} G_\delta^{\widehat{\omega}_\delta^\varepsilon}(0, z) \widehat{d}_\delta^\varepsilon(z)}{\sum_{z \in \mathbb{Z}^d} G_\delta^{\widehat{\omega}_\delta^\varepsilon}(0, z)} = \lim_{\delta \rightarrow 1} \frac{\mathbb{E}[X_{\tau_\delta}]}{\mathbb{E}[\tau_\delta]} = v_\ell(1 - \varepsilon),$$

where $\widehat{d}_\delta^\varepsilon(z) = \sum_{e \in \nu} \widehat{p}_\delta^\varepsilon(z, e)e$.

Let C_δ^ε be the convex hull of all $\widehat{d}_\delta^\varepsilon(z)$ for $z \in \mathbb{Z}^d$, then an immediate consequence of the previous proposition is the following

Proposition 3.3. *For $\varepsilon > 0$ we have that $v_\ell(1 - \varepsilon)$ is an accumulation point of C_δ^ε as δ goes to 1.*

The proofs of both propositions are contained in the proof of Proposition 2 in [22] and rely only on the existence of a limiting velocity, which is a consequence of Theorem 2.1.

In order to ease notations we will from time to time drop the dependence with respect to ε of the expectation $\mathbf{E}_{1-\varepsilon}[\cdot]$.

Let us now give a quick sketch of the proof of the continuity of the speed. A way of understanding $\widehat{d}_\delta^\varepsilon(z)$ is to decompose the expression of Kalikow's drift according to the possible configurations at z

$$\begin{aligned} (3.1) \quad \widehat{d}_\delta^\varepsilon(z) &= \sum_{e \in \nu} \sum_{A \in \{0,1\}^\nu} \frac{\mathbf{E}\left[\mathbf{1}\{\mathcal{I}\}\mathbf{1}\{\mathcal{C}(z) = A\}G_\delta^\omega(0, z)p(z, e)e\right]}{\mathbf{E}\left[\mathbf{1}\{\mathcal{I}\}G_\delta^\omega(0, z)\right]} \\ &= \sum_{A \in \{0,1\}^\nu \setminus \nu} \frac{\mathbf{E}\left[\mathbf{1}\{\mathcal{I}\}\mathbf{1}\{\mathcal{C}(z) = A\}G_\delta^\omega(0, z)\right]}{\mathbf{E}\left[\mathbf{1}\{\mathcal{I}\}G_\delta^\omega(0, z)\right]} d_A \\ &= \sum_{A \in \{0,1\}^\nu \setminus \nu} \mathbf{P}[\mathcal{C}(z) = A] \frac{\mathbf{E}\left[\mathbf{1}\{\mathcal{I}\}G_\delta^\omega(0, z)|\mathcal{C}(z) = A\right]}{\mathbf{E}\left[\mathbf{1}\{\mathcal{I}\}G_\delta^\omega(0, z)\right]} d_A, \end{aligned}$$

where $d_A = \sum_{e \in A} p^A(e)e$ is the drift under the configuration A .

Since $\mathbf{P}[\mathcal{C}(z) = A] \sim \varepsilon^{|A|}$ for any $A \in \nu$, if we want to find the limit of $\widehat{d}_\delta^\varepsilon(z)$ as ε goes to 0, it is natural to conjecture that the term corresponding to $\{\mathcal{C}(z) = \emptyset\}$ is dominant in (3.1). For this, recalling the notations from (2.1), we may find an upper bound on

$$(3.2) \quad \frac{\mathbf{E}\left[\mathbf{1}\{\mathcal{I}\}G_\delta^\omega(0, z)|\mathcal{C}(z) = A\right]}{\mathbf{E}\left[\mathbf{1}\{\mathcal{I}\}G_\delta^\omega(0, z)\right]} = \frac{\mathbf{E}\left[\mathbf{1}\{\mathcal{I}(\omega^{z,A})\}G_\delta^{\omega^{z,A}}(0, z)\right]}{\mathbf{E}\left[\mathbf{1}\{\mathcal{I}\}G_\delta^\omega(0, z)\right]},$$

for $z \in \mathbb{Z}^d$, $A \in \{0, 1\}^\nu \setminus \nu$ and $\delta < 1$ which is uniform in z for δ close to 1, to be able to apply Proposition 3.3 and show that $|v_\ell(1 - \varepsilon) - d_\emptyset| = O(\varepsilon)$.

Let us show why the terms in (3.2) are upper bounded. It is easy to see that the denominator is greater than $\gamma_1 \mathbf{E}[\mathbf{1}\{\mathcal{I}(\omega^{z,1})\} G_\delta^{\omega^{z,1}}(0, z)]$, so we essentially need to show that closing some edges adjacent to z cannot increase the quantity appearing in (3.2) by a huge amount. That is: for $A \in \{0, 1\}^\nu$,

$$(3.3) \quad \mathbf{E}[\mathbf{1}\{\mathcal{I}(\omega^{z,A})\} G_\delta^{\omega^{z,A}}(0, z)] \leq \gamma_2 \mathbf{E}[\mathbf{1}\{\mathcal{I}(\omega^{z,1})\} G_\delta^{\omega^{z,1}}(0, z)].$$

In order to show that closing edges cannot have such a tremendous effect, let us first remark that the Green function can be written as $G_\delta^\omega(0, z) = P_0^\omega[T_z < \tau_\delta] G_\delta^\omega(z, z)$. When we close some edges we might create a trap, for example a long “corridor” can be transformed into a “dead-end” and this effect can, in the quenched setting, increase arbitrarily $G_\delta^\omega(z, z)$, the number of returns to z .

The first step is to quantify this effect, we will essentially show in Section 4 that $G_\delta^{\omega^{z,\nu \setminus A}}(z, z) \leq G_\delta^{\omega^{z,1}}(z, z) + L_z(\omega)$ (see Proposition 4.2) where $L_z(\omega)$ is in some sense, to be defined later, a “local” quantity around z (see Proposition 4.1 and Proposition 5.2). With this random variable we try to quantify how far from z the random walk has to go to find a “regular” environment without traps where the effect of the modification around z is “forgotten”. In this upper bound, we may get rid of the term $G_\delta^{\omega^{z,1}}(z, z)$ which is, once multiplied by $\mathbf{1}\{\mathcal{I}\} P_0^\omega[T_z < \tau_\delta] \leq \mathbf{1}\{\mathcal{I}(\omega^{z,1})\} P_0^{\omega^{z,1}}[T_z < \tau_\delta]$, of the same type as the terms on the right-hand side of (3.3).

The second step is to understand how the “local” quantity L_z is correlated with the hitting probability. The intuition here is that the hitting probability depends on the environment as a whole but that a very local modification of the environment cannot change tremendously the value of the hitting probability. On a more formal level this corresponds to (see Lemma 6.1) $\mathbf{E}[\mathbf{1}\{\mathcal{I}\} P_0^\omega[T_z < \tau_\delta] L_z(\omega)] \leq \gamma_3 \mathbf{E}[\mathbf{1}\{\mathcal{I}\} P_0^\omega[T_z < \tau_\delta]]$ where γ_3 is some moment of L_z , which is a sufficient upper bound.

Before turning to the proof, we emphasize that the aim of Section 4 and Section 5, is mainly to introduce the so-called “local” quantities, which is done at the beginning of Section 4, and prove some properties on these quantities, see Proposition 4.2, Proposition 5.2 and Proposition 4.1. The corresponding proofs are essentially unrelated to the rest of the paper and may be skipped in a first reading, to concentrate on the actual proof of the continuity which is in Section 6.

4. RESISTANCE ESTIMATES

In this section we shall introduce some elements of electrical networks theory (see [16]) to estimate the variations on the diagonal of the Green

function induced by a local modification of the state of the edges around a vertex x . Our aim is to show that we can get efficient upper bounds using only the local shape of the environment.

Let us denote the effective resistance between $x \in \mathbb{Z}^d$ and a subgraph H' of a certain finite graph H by $R^H(x \leftrightarrow H')$. Denoting $V(H')$ the vertices of H' , it can be defined through Thomson's principle (see [16])

$$R^H(x \leftrightarrow H') = \inf \left\{ \sum_{e \in H} r(e) \theta^2(e), \theta(\cdot) \text{ is a unit flow from } x \text{ to } V(H') \right\},$$

and this infimum is reached for the current flow from x to $V(H')$. Under the environment ω , we will denote the resistance between x and y by $R^\omega(x \leftrightarrow y)$.

For a fixed $\omega \in \Omega$, we add a cemetery point Δ which is linked to any vertex x of $K_\infty(\omega)$ with a conductance such that at x the probability of going to Δ is $1 - \delta$ and denote the associated weighted graph by $\omega(\delta)$. We denote $\pi^{\omega(\delta)}(x)$ the sum of the conductances of edges adjacent to x in $\omega(\delta)$ and we define $R^{\omega(\delta)}(x \leftrightarrow \Delta)$ to be the limit of $R^{\omega(\delta)}(x \leftrightarrow \omega \setminus \omega_n)$ where ω_n is any increasing exhaustion of subgraphs of ω . In this setting we have,

$$(4.1) \quad \pi^{\omega(\delta)}(x) = \frac{\pi^\omega(x)}{\delta} \text{ and } r^{\omega(\delta)}([x, \Delta]) = \frac{1}{\pi^{\omega(\delta)}(x)} \frac{1}{1 - \delta} = \frac{1}{\pi^\omega(x)} \frac{\delta}{1 - \delta}.$$

We emphasize the fact that changing the state of an edge $[x, y]$ changes the values of $r^{\omega(\delta)}([x, \Delta])$ and $r^{\omega(\delta)}([y, \Delta])$, it can nevertheless be noted that Rayleigh's monotonicity principle (see [16]) is preserved, i.e. if we increase (resp. decrease) the resistance of one edge of the graph the effective resistance increases (resp. decreases).

There is no ambiguity to simplify the notations by setting $R^\omega(x \leftrightarrow \Delta) := R^{\omega(\delta)}(x \leftrightarrow \Delta)$ for $x \in \mathbb{Z}^d$ and $r^\omega(e) := r^{\omega(\delta)}(e)$ for e any edge of $\omega(\delta)$. It is classic (and can be found as an exercise in chapter 2 of [16]) that

Lemma 4.1. *For any $\delta < 1$, we have*

$$G_\delta^\omega(x, x) = \pi^{\omega(\delta)}(x) R^\omega(x \leftrightarrow \Delta).$$

Hence to understand, in a rough sense, how closing edges might increase the number of returns at z , we can concentrate on understanding the effect of closing edges on the effective resistance. By Rayleigh's monotonicity principle, given a vertex x , the configuration in $A = B^E(x, r)$ which has the lowest resistance between any point and Δ is the one here all edges are open. Hence, for configurations $B \in \{0, 1\}^A$, we want to get an upper bound $R^{\omega^{A,B}}(x \leftrightarrow \Delta)$ in terms of $R^{\omega^{A,0}}(x \leftrightarrow \Delta)$ and of "local" quantities.

Let us begin with a heuristic description of configurations which are likely to increase strongly the number of returns when we close an edge. There are mainly two situations that can occur (see Figure 1)

- (1) the vertex x is in a long corridor, which is turned into a “dead-end” if we close only an edge, hence increasing the number of returns,
- (2) if closing an edge adjacent to x creates a new finite cluster K , the number of returns to x can be tremendously increased. Indeed because of the geometrical killing parameter, when the particle gets stuck in K for a long time it may die (i.e. go to Δ), hence by closing the edge linking x to K , we can remove this escape possibility and increase the number of returns to x .

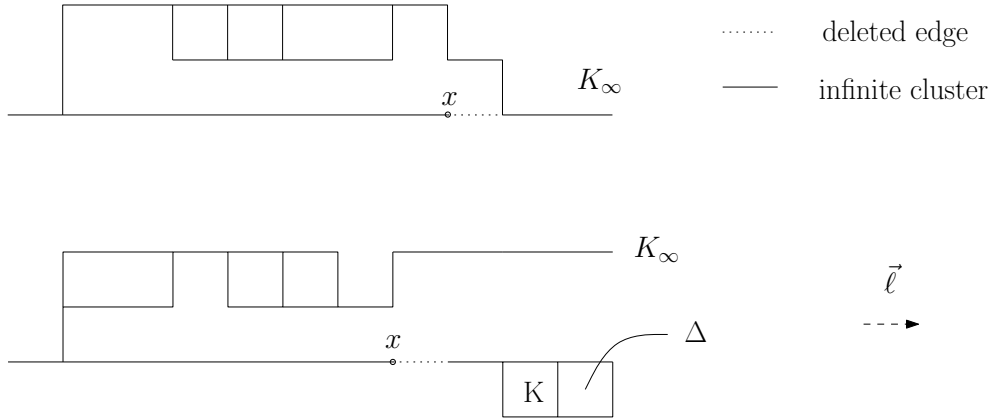

FIGURE 1. Configurations where one deleted edge increases $G_\delta(x, x)$

We want to find properties of the environment which will quantify how strongly the number of returns will increase. In order to find a quantity which controls the effect of the first type of configurations we denote, for $A = B^E(x, r)$,

$$(4.2) \quad M_A(\omega) = \begin{cases} \infty & \text{if } \forall y \in \partial A, y \notin K_\infty(\omega^{A,0}), \\ \max_{y_1, y_2 \in \partial A \cap K_\infty(\omega^{A,0})} d_{\omega^{A,0}}(y_1, y_2) & \text{otherwise,} \end{cases}$$

which is the maximal distance between vertices of $\partial A \cap K_\infty(\omega^{A,0})$ in the infinite cluster of $\omega^{A,0}$. It is important to notice that the notation $K_\infty(\omega^{A,0})$ makes sense, since it is classical that \mathbf{P} -a.s. modifying the states of a finite set of edges does not create multiple infinite clusters.

This quantity will help us give upper bounds on the number of returns to x after having closed some adjacent edges. Indeed even if the “best escape way to infinity” is closed, M_A tells us in some sense how much more the particle has to struggle to get back onto this good escape route, even though some additional edges are closed.

In order to control the effect of the second type of bad configurations, we first want to find out if we are likely to go to Δ during an excursion into the part we called K . For this we introduce a way to measure the size of the biggest finite cluster of $\omega^{A,0}$ which intersects ∂A ,

$$(4.3) \quad T_A(\omega) = \begin{cases} 0 & \text{if } \forall y \in \partial A, y \in K_\infty(\omega^{A,0}), \\ \max_{y \in \partial A, y \notin K_\infty(\omega^{A,0})} |\partial_E K_{\omega^{A,0}}(y)| & \text{otherwise,} \end{cases}$$

which gives an indication on the time of an excursion into K , hence on the probability of going to Δ during this excursion.

The idea now is to find an alternate trap close to x , in which the walker is likely to go to Δ before returning to x to replace the role of K . This alternate trap ensures that the number of return to x cannot be too big even in the case where all the accesses to parts such as K adjacent to x are closed. For this let us denote $\eta \geq 1$ depending on d and ℓ such that

$$(4.4) \quad \text{for all } n \geq 1, \quad e^{2\lambda(\eta-1)n} \geq \kappa_1^2(1 + |B(0, n)|),$$

and $H'_A(\omega)$ the hyperplane $\{y, y \cdot \vec{\ell} \geq x \cdot \vec{\ell} + \eta T_A(\omega)\}$. Any point of this hyperplane can be seen as an alternate trap since the particle is very unlikely to return to x when it reaches H'_A . Then a relevant quantity to control the effect of the second type of configurations is the distance between x and this hyperplane, which quantifies the difficulty to reach an alternate strong trap.

In order to define these quantities we need to know the infinite cluster K_∞ , hence they are not ‘‘local’’ quantities. Nevertheless we are able to define random variables which are ‘‘local’’ and fulfill the same functions. For $A = B^E(x, r)$, we denote $L_A^1(\omega)$ the smallest positive integer such that all $y \in \partial A$ which are connected to $\partial B(x, L_A^1(\omega))$ in $\omega^{A,0}$, are connected to each other using only edges of $B^E(x, L_A^1(\omega)) \cap \omega^{A,0}$. We always have $L_A^1(\omega) < \infty$ by uniqueness of the infinite cluster. Consequently there are two types of vertices in ∂A , first those which are not connected to $\partial B(x, L_A^1(\omega))$ in $\omega^{A,0}$ (hence in a finite cluster of $\omega^{A,0}$) and then those which are, the latter being all inter-connected in $B(x, L_A^1(\omega)) \cap \omega^{A,0}$.

Set $H_A(\omega)$ to be the hyperplane $\{y, y \cdot \vec{\ell} \geq x \cdot \vec{\ell} + \eta L_A^1(\omega)\}$ and finally let us define $L_A(\omega)$ the smallest integer such that

- (1) either ∂A is connected to $H_A(\omega)$ using only edges of $B^E(x, L_A(\omega)) \cap \omega^{A,0}$,
- (2) or ∂A is not connected to $B^E(x, L_A(\omega))$, which can only happen if $\partial A \cap K_\infty = \emptyset$,

and in order to make the notations lighter we use

$$(4.5) \quad L_{z,k} := L_{B^E(z,k)} \text{ and } L_z = L_{z,1}.$$

Using this definition for L_A we get an upper bound for the quantities M_A and $d_\omega(x, H'_A)$ on the event that $x \in K_\infty$ which is the only case we will need to consider. Now we can easily obtain, the proof is left to the reader, the following proposition

Proposition 4.1. *For a ball $A = B^E(x, r)$, set $\mathcal{F}_{x,n}$ the σ -field generated by $\{\omega(e), e \in B^E(x, n)\}$, we have the following*

- (1) $L_A(\omega)$ does not depend on the state of the edges in A ,
- (2) $L_A(\omega)$ is a stopping time with respect to $(\mathcal{F}_{x,n})_{n \geq 0}$, in particular the event $\{L_A(\omega) = k\}$ does not depend on the state of the edges of $B^E(x, k)^c = E(\mathbb{Z}^d) \setminus B^E(x, k)$,
- (3) $r \leq L_A(\omega) < \infty$, \mathbf{P} -a.s..

The second property is one of the two central properties for what we call a “local” quantity. Recalling the notations (2.1) and (2.2), let us prove the following

Proposition 4.2. *Set $A = B^E(x, r)$ with $r \geq 1$, $\delta < 1$ and $\omega \in \Omega$. Suppose that $y \in K_\infty(\omega)$ and $\partial A \cap K_\infty(\omega) \neq \emptyset$. We have*

$$R^\omega(y \leftrightarrow \Delta) \leq R^{\omega^{A,1}}(y \leftrightarrow \Delta) + C_1 L_A(\omega)^{C_2} e^{2\lambda(L_A(\omega) - x \cdot \vec{\ell})},$$

where C_1 and C_2 depend only on d and ℓ .

Here the correcting term is essentially of the same order as the largest between

- (1) the resistance of paths linking the vertices of $\partial A \cap K_\infty(\omega^{A,0})$ inside $B(x, L_A)$,
- (2) the resistance of paths linking x to H_A inside $B(x, L_A)$.

Proof. Let us introduce

$$A^+ = B(x, r) \cup \bigcup_{a \in \partial A, a \notin K_\infty(\omega^{A,0})} K_{\omega^{A,0}}(a) \text{ and } A^{+, \delta} = \bigcup_{a \in A^+} \{[a, \Delta]\},$$

moreover we set

$$A^- = B(x, r - 1) \cup \bigcup_{a \in \partial A, a \notin K_\infty(\omega^{A,0})} K_{\omega^{A,0}}(a) \text{ and } A^{-, \delta} = \bigcup_{a \in A^-} \{[a, \Delta]\}.$$

Let ω_n be an exhaustion of ω and n_0 such that $B(x, L_A(\omega)) \cap \omega \subset \omega_{n_0}$ and y is connected to ∂A in ω_{n_0} . Set $n \geq n_0$, we denote $\theta(\cdot)$ any unit flow from y to $\omega(\delta) \setminus \omega_n$ using only edges of $\omega_n(\delta)$. By Thomson’s principle, we get

$$(4.6) \quad \begin{aligned} & R^{\omega(\delta)}(y \leftrightarrow \omega(\delta) \setminus \omega_n) - R^{\omega^{A,1}(\delta)}(y \leftrightarrow \omega^{A,1}(\delta) \setminus \omega_n^{A,1}) \\ & \leq \sum_{e \in \omega(\delta)} (r^\omega(e) \theta(e)^2 - r^{\omega^{A,1}}(e) i_0(e)^2), \end{aligned}$$

where $i_0(\cdot)$ denotes the unit current flow from z to $\omega^{A,1}(\delta) \setminus \omega_n^{A,1}$. We want to apply the previous equation with a flow $\theta(\cdot)$ which is close to the current flow $i_0(\cdot)$. Since the latter does not necessarily use only edges of ω we will need to redirect the part flowing through A .

For a vertex $a \in \partial A$, we denote $i_0^A(a) = \sum_{e \in \nu, [a, a+e] \in A} i_0([a, a+e])$ the quantity of current entering A through a . Hence we can partition ∂A into

- (1) a_1, \dots, a_k the vertices of $\partial A \cap K_\infty(\omega^{A,0})$ such that $i_0^A(a) \geq 0$,
- (2) a_{k+1}, \dots, a_l the vertices of $\partial A \cap K_\infty(\omega^{A,0})$ such that $i_0^A(a) < 0$,
- (3) a_{l+1}, \dots, a_m the vertices of $\partial A \setminus K_\infty(\omega^{A,0})$.

Moreover we denote

$$i_0^+(\Delta) = \sum_{e \in A^+, \delta} i_0(e) \text{ and } i_0^-(\Delta) = \sum_{e \in A^-, \delta} i_0(e).$$

Let us first assume $y \in K_\infty(\omega^{A,0})$, in particular $y \notin B(x, r-1)$. The following facts are classical (see e.g. [16] chapter 2)

- (1) for any $e \in E(\mathbb{Z}^d)$, we have $|i_0(e)| \leq 1$,
- (2) the intensity entering $B(x, r-1)$ is equal to the intensity leaving $B(x, r-1)$, i.e.

$$\sum_{i \leq k} i_0^A(a_i) = i_0^-(\Delta) - \sum_{j \in [k+1, l]} i_0^A(a_j).$$

Using the two previous remarks, we see it is possible to find a collection $\nu(i, j)$ with $i \in [1, k]$ and $j \in [k+1, l] \cup \{\Delta\}$ such that

- (1) for all i, j , we have $\nu(i, j) \in [0, 1]$,
- (2) for all $j \in [k+1, l]$, it holds that $\sum_{i \leq k} \nu(i, j) = -i_0^A(a_j)$,
- (3) for all $i \in [1, k]$, we have $\sum_{j \in [k+1, l] \cup \{\Delta\}} \nu(i, j) = i_0^A(a_i)$,
- (4) it holds that $\sum_{i \leq k} \nu(i, \Delta) = i_0^-(\Delta)$,

which should be seen as a way of matching the flow entering and leaving $B(x, r-1)$.

Let us denote $\vec{\mathcal{P}}(i, j)$ one of the directed paths between a_i and a_j in $\omega^{A,0} \cap B^E(x, L_A^1(\omega))$. Let $\vec{\mathcal{Q}}$ be one of the directed paths from ∂A to $H_A(\omega)$ in $\omega^{A,0} \cap B^E(x, L_A(\omega))$ and let us denote a_{j_0} (with necessarily $j_0 \leq l$) its starting point and h_1 its endpoint. The existence of those paths is ensured by the definitions of L_A^1 , L_A and H_A and the fact that $\partial A \cap K_\infty \neq \emptyset$.

Finally let us notice that the values of the resistances $r^\omega([a, \Delta])$ and $r^{\omega^{A,1}}([a, \Delta])$ might differ for $a \in \partial A$ so that to get further simplifications in (4.6), it is convenient to redirect the flow using these edges too. We introduce the unique

flow (see Figure 2) defined by

$$\theta_0(\vec{e}) = \begin{cases} 0 & \text{if } e \in A^{+, \delta}, \\ 0 & \text{if } e \in E(A^+), \\ i_0(\vec{e}) + i_0^+(\Delta) & \text{if } \vec{e} = [h_1, \Delta], \\ i_0(\vec{e}) + \sum_{i \leq k, j \in [k+1, l]} \nu(i, j) \mathbf{1}\{\vec{e} \in \vec{\mathcal{P}}(i, j)\} \\ + \sum_{i \leq k} \nu(i, \Delta) \mathbf{1}\{\vec{e} \in \vec{\mathcal{P}}(i, j_0)\} + i_0^+(\Delta) \mathbf{1}\{\vec{e} \in \vec{\mathcal{Q}}\} \\ + \sum_{i \leq l} i_0([a_i, \Delta]) \mathbf{1}\{\vec{e} \in \vec{\mathcal{P}}(i, j_0)\} & \text{else.} \end{cases}$$

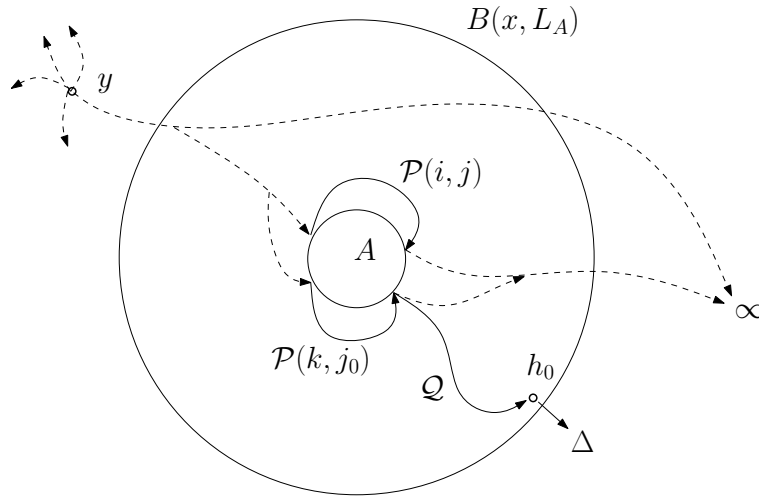

FIGURE 2. The flow $\theta_0(\cdot)$ in the case where $y \in K_\infty(\omega^{A,0})$

In words, we could say that we have redirected parts of $i_0(\cdot)$ in order to go around A and the flow going from A to Δ is first sent to a_{j_0} , then to h_1 and finally to Δ . We have the following properties

- (1) $\theta_0(\cdot)$ is a unit flow from y to $\omega(\delta) \setminus \omega_n$,
- (2) $|\theta_0(e)| \leq 5|\partial A|^2$ for all $e \in E(\mathbb{Z}^d)$,
- (3) $\theta_0(\cdot)$ coincides with $i_0(\cdot)$ except on the edges of $E(A^+)$, $A^{+, \delta}$, \mathcal{Q} , $[h_1, \Delta]$ and $\mathcal{P}(i, j)$ for $i, j \leq k + l$,
- (4) $r^\omega(\cdot)$ coincides with $r^{\omega^{A,1}}(\cdot)$ except on the edges of $E(A^+)$ and $A^{+, \delta}$.

Hence recalling (4.6) we get

$$\begin{aligned} (4.7) \quad & R^{\omega(\delta)}(y \leftrightarrow \omega(\delta) \setminus \omega_n) - R^{\omega^{A,1}(\delta)}(y \leftrightarrow \omega^{A,1}(\delta) \setminus \omega_n^{A,1}) \\ & \leq \sum_{e \in \mathcal{P}(i,j) \cup \mathcal{Q}} r^\omega(e) (\theta_0(e)^2 - i_0(e)^2) + r^\omega([h_1, \Delta]) (i_0^+(\Delta) + i_0([h_1, \Delta]))^2 \\ & \quad - \sum_{e \in A^{+, \delta}} r^\omega(e) i_0(e)^2 - r^\omega([h_1, \Delta]) i_0([h_1, \Delta])^2 \end{aligned}$$

$$\begin{aligned} &\leq 50\rho_d |\partial A|^6 L_A^d e^{2\lambda(L_A - x \cdot \vec{\ell})} + r^\omega([h_1, \Delta])(i_0^+(\Delta) + i_0([h_1, \Delta]))^2 \\ &\quad - \sum_{e \in A^{+, \delta}} r^\omega(e) i_0(e)^2 - r^\omega([h_1, \Delta]) i_0([h_1, \Delta])^2, \end{aligned}$$

where we used that $r^\omega(e) \leq e^{2\lambda(L_A - x \cdot \vec{\ell})}$ for $e \in \mathcal{P}(i, j) \cup \mathcal{Q}$ and that there are at most $(1 + |\partial A|^2)\rho_d L_A^d \leq 2\rho_d |\partial A|^2 L_A^d$ such edges in those paths. These properties being a consequence of the fact that $\mathcal{P}(i, j)$ and \mathcal{Q} are contained in $B^E(x, L_A^1(\omega))$.

Since $|\partial A| \leq \rho_d r^d \leq \rho_d L_A^d$ by the third property of Proposition 4.1, the first term is of the form announced in the proposition, the remaining issue is to control the remaining terms. First, we have by definition

$$\sum_{e \in A^{+, \delta}} r^\omega(e) i_0(e)^2 = \sum_{a \in A^+} r^\omega([a, \Delta]) i_0([a, \Delta])^2,$$

and since for $a \in K_\infty(\omega)$, we have using (4.1) and (2.5) that

$$\kappa_1 e^{-2\lambda a \cdot \vec{\ell}} \frac{\delta}{1 - \delta} \geq r^\omega([a, \Delta]) \geq \frac{1}{\kappa_1} e^{-2\lambda a \cdot \vec{\ell}} \frac{\delta}{1 - \delta}.$$

Furthermore, since for any $a \in A^+$ we have $a \cdot \vec{\ell} \leq x \cdot \vec{\ell} + L_A^1$ and since $h_1 \in H_A(\omega)$ we have $h_1 \cdot \vec{\ell} \geq x \cdot \vec{\ell} + \eta L_A^1 \geq a \cdot \vec{\ell} + (\eta - 1)L_A^1$ so that the definition of η at (4.4) yields

$$\frac{1}{\kappa_1} e^{-2\lambda a \cdot \vec{\ell}} \geq \frac{1}{\kappa_1} e^{-2\lambda h_1 \cdot \vec{\ell}} e^{2\lambda(\eta-1)L_A^1(\omega)} \geq \kappa_1 (1 + |B(0, L_A^1)|) e^{-2\lambda h_1 \cdot \vec{\ell}}.$$

Since A^+ is contained in $B(x, L_A^1(\omega))$, the two previous equations yield

$$r^\omega([a, \Delta]) \geq \kappa_1 (1 + |A^+|) e^{-2\lambda h_1 \cdot \vec{\ell}} \frac{\delta}{1 - \delta} \geq (1 + |A^+|) r^\omega([h_1, \Delta]),$$

and hence

$$\begin{aligned} &\sum_{e \in A^{+, \delta}} r^\omega(e) i_0(e)^2 + r^\omega([h_1, \Delta]) i_0([h_1, \Delta])^2 \\ &\geq r^\omega([h_1, \Delta]) (1 + |A^+|) \left(i_0([h_1, \Delta])^2 + \sum_{e \in A^+} i_0(e)^2 \right) \\ &\geq r^\omega([h_1, \Delta]) (i_0^+(\Delta) + i_0([h_1, \Delta]))^2, \end{aligned}$$

where we used Cauchy-Schwarz in the last inequality.

Hence the remaining terms in (4.7) are non-positive and we have shown that

$$R^{\omega(\delta)}(y \leftrightarrow \omega(\delta) \setminus \omega_n) - R^{\omega^{A,1}(\delta)}(y \leftrightarrow \omega^{A,1}(\delta) \setminus \omega_n^{A,1}) \leq 50\rho_d^7 L_A^{7d} e^{2\lambda(L_A - x \cdot \vec{\ell})},$$

and letting n go to infinity yields the result in the case where $y \in K_\infty(\omega^{A,0})$.

Let us come back to the remaining case where $y \in K_\infty(\omega) \setminus K_\infty(\omega^{A,0})$. Keeping the same notations, we see that obviously there exists $j_1 \leq l$ such that $a_{j_1} \in K_\infty(\omega^{A,0})$ which is connected in ω to y using only vertices of A^+ , let us denote $\vec{\mathcal{R}}$ path connecting a_{j_1} and y in $\omega \cap A^+$.

Introducing the unique flow (see Figure 3) defined by

$$\theta'_0(\vec{e}) = \begin{cases} 1 & \text{if } \vec{e} \in \vec{\mathcal{R}}, \\ 0 & \text{if } e \in A^{+,\delta} \cup E(A^+) \setminus \mathcal{R}, \\ i_0(\Delta) + i_0([h_1, \Delta]) & \text{if } \vec{e} = [h_1, \Delta] \\ i_0(\vec{e}) + \sum_{j \leq l} i_0^A(j) \mathbf{1}\{\vec{e} \in \vec{\mathcal{P}}(j_1, j)\} \\ + \sum_{i \leq l} i_0([a_i, \Delta]) \mathbf{1}\{\vec{e} \in \vec{\mathcal{P}}(i, j_0)\} \\ + i_0^-(\Delta) \mathbf{1}\{\vec{e} \in \vec{\mathcal{P}}(j_1, j_0)\} + i_0^+(\Delta) \mathbf{1}\{\vec{e} \in \vec{\mathcal{Q}}\} & \text{else,} \end{cases}$$

for which we can get the same properties as for $\theta_0(\cdot)$.

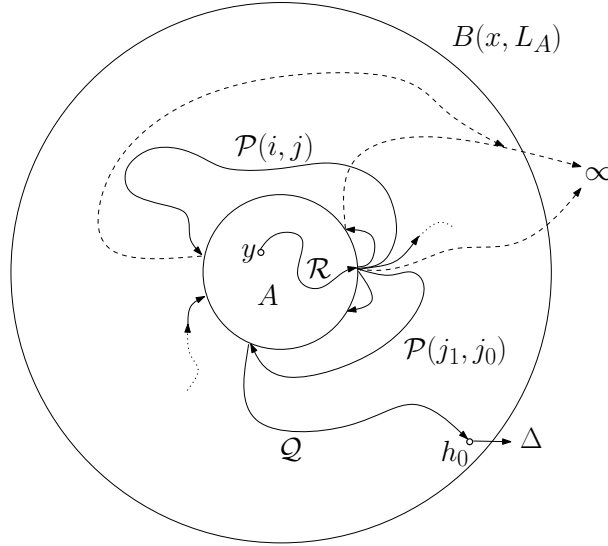

FIGURE 3. The flow $\theta'_0(\cdot)$ in the case where $y \in K_\infty(\omega) \setminus K_\infty(\omega^{A,0})$

The computation of the energy of $\theta'_0(\cdot)$ is essentially similar to that of $\theta_0(\cdot)$ and we get

$$\begin{aligned} & R^{\omega(\delta)}(y \leftrightarrow \omega(\delta) \setminus \omega_n) - R^{\omega^{A,1}(\delta)}(y \leftrightarrow \omega^{A,1}(\delta) \setminus \omega_n^{A,1}) \\ & \leq CL_A^{7d} e^{2\lambda(L_A - x \cdot \vec{\ell})} + \sum_{e \in \mathcal{R}} r^\omega(e) \\ & \leq CL_A^{7d} e^{2\lambda(L_A - x \cdot \vec{\ell})}, \end{aligned}$$

since $|\mathcal{R}| \leq |A^+| \leq \rho_d L_A^d$ and $r^\omega(e) \leq e^{2\lambda(L_A - x \cdot \vec{\ell})}$ for $e \in \mathcal{R}$. The result follows. \square

We set for $x, y \in \mathbb{Z}^d$ and $Z \subset \mathbb{Z}^d$,

$$(4.8) \quad G_{\delta, Z}(x, y) = E_x^\omega \left[\sum_{k=0}^{T_Z} \delta^k \mathbf{1}\{X_k = y\} \right],$$

and similarly we can define $R^\omega(x \leftrightarrow Z \cup \Delta)$ to be the limit of $R^{\omega(\delta)}(x \leftrightarrow Z \cup \{\omega(\delta) \setminus \omega_n\})$ where ω_n is any increasing exhaustion of subgraphs of ω . We can get

Lemma 4.2. *For any $\delta < 1$, we have for $x, z \in \mathbb{Z}^d$,*

$$G_{\delta, \{z\}}^\omega(x, x) = \pi^{\omega(\delta)}(x) R^\omega(x \leftrightarrow z \cup \Delta).$$

In a way similar to the proof of Proposition 4.2, we get

Proposition 4.3. *Set $A = B^E(x, r)$, $B \in \{0, 1\}^A$, $\delta < 1$, $z \in \mathbb{Z}^d$ and $\omega \in \Omega$. Suppose that $y, z \in K_\infty(\omega)$ and $\partial A \cap K_\infty(\omega) \neq \emptyset$. We have*

$$R^\omega(y \leftrightarrow z \cup \Delta) \leq R^{\omega^{A,1}}(y \leftrightarrow z \cup \Delta) + C_1 L_A(\omega)^{C_2} e^{2\lambda(L_A(\omega) - x \cdot \vec{\ell})},$$

where C_1 and C_2 depend only on d and ℓ .

We assume without loss of generality the constants are the same as Proposition 4.2.

Proof. This time let us denote $i_0(\cdot)$ by the unit current flow from y to $z \cup \{\omega(\delta) \setminus \omega_n\}$.

The case where $z \in K_\infty(\omega^{A,0})$ can be treated using the same flows as in the proof of Proposition 4.2 and we will not give further details.

In order to treat the case where $z \notin K_\infty(\omega^{A,0})$ and $y \in K_\infty(\omega^{A,0})$. We keep the notations of the previous proof for the partition $(a_i)_{1 \leq i \leq m}$ of ∂A , $i_0^+(\Delta)$, $i_0^-(\Delta)$, A^+ and $A^{+, \delta}$. We set

$$i_0^z = \sum_{e \in \nu} i_0([z + e, z]).$$

Similarly, we can find a family $\nu(i, j)$ with $i \in [1, k]$ and $j \in [k+1, l] \cup \{\Delta\} \cup \{z\}$ such that

- (1) for all i, j , we have $\nu(i, j) \in [0, 1]$,
- (2) for all $j \in [k+1, l]$, it holds that $\sum_{i \leq k} \nu(i, j) = -i_0^A(a_j)$,
- (3) we have $\sum_{i \leq k} \nu(i, \Delta) = i_0^-(\Delta)$,
- (4) it holds that $\sum_{i \leq k} \nu(i, z) = i_0^z$,
- (5) for all $i \in [1, k]$ we have $\sum_{j \in [k+1, l] \cup \{\Delta\} \cup \{z\}} \nu(i, j) = i_0^A(a_i)$.

We use again the same notations for $\mathcal{P}(i, j)$, \mathcal{Q} , j_0 and h_1 and add an index $j_2 \leq l$ such that z is connected inside A^+ to a_{j_2} and $\vec{\mathcal{S}}$ the corresponding

directed path. We set

$$\theta_0(\vec{e}) = \begin{cases} i_0^z(\vec{e}) & \text{if } \vec{e} \in \vec{\mathcal{S}}, \\ 0 & \text{if } e \in A^{+, \delta} \cup E(A^+) \setminus \mathcal{S}, \\ i_0(\Delta) + i_0([h_1, \Delta]) & \text{if } \vec{e} = [h_1, \Delta] \\ i_0(\vec{e}) + i_0^+(\Delta) \mathbf{1}\{\vec{e} \in \vec{\mathcal{Q}}\} & \\ \quad + \sum_{i \leq k, j \in [k+1, l]} \nu(i, j) \mathbf{1}\{\vec{e} \in \vec{\mathcal{P}}(i, j)\} & \\ \quad + \sum_{i \leq k} \nu(i, \Delta) \mathbf{1}\{\vec{e} \in \vec{\mathcal{P}}(i, j_0)\} & \\ \quad + \sum_{i \leq k} \nu(i, z) \mathbf{1}\{\vec{e} \in \vec{\mathcal{P}}(i, j_2)\} & \\ \quad + \sum_{i \leq l} i_0([a_i, \Delta]) \mathbf{1}\{\vec{e} \in \vec{\mathcal{P}}(i, j_0)\} & \text{else,} \end{cases}$$

which is similar to the flow considered in Proposition 4.2 except that the flow naturally supposed to escape at z is, instead of entering A , redirected to a_{j_2} and from there sent to z . Using this flow with Thomson's principle yields similar computations as in Proposition 4.2 and thus we obtain a similar result.

The case where $z \notin K_\infty(\omega^{A,0})$ and $0 \notin K_\infty(\omega^{A,0})$ can be easily adapted from the proof above and the second part of the proof of Proposition 4.2. \square

5. PERCOLATION ESTIMATE

We want to give tail estimates on L_A^1 and L_A for some ball $A = B(x, r)$. More precisely we want to show for any $C > 0$, we have $\mathbf{E}_{1-\varepsilon}[e^{CL_A}] < \infty$ for ε small enough, the exact statement can be found in Proposition 5.2. Let us recall the definitions of M_A and T_A at (4.2) and (4.3). We see that all vertices of ∂A are either in finite clusters of $\omega^{A,0}$, which are included in $B(x, r + T_A)$, or inter-connected in $B(x, r + M_A)$. Hence we get by the remarks above (4.5) that

$$(5.1) \quad L_A^1 \leq r + \max(M_A, T_A).$$

Recalling the definitions of L_A and H_A below (4.4), our overall strategy for proving the existence of arbitrarily large exponential moments is the following: if L_A is large then there are two cases.

- (1) The random variable L_A^1 is large. This means by (5.1) that either M_A or T_A is large. The random variable T_A cannot be large with high probability, since the distance in the percolation cluster cannot be much larger than the distance in \mathbb{Z}^d (see Lemma 5.2) and neither can M_A since finite cluster are small in the supercritical regime (see Lemma 5.3).
- (2) Otherwise the distance from x to H_A in large in the percolation cluster is large even though it is not large in \mathbb{Z}^d . Once again this is unlikely,

in fact for technical reasons it appears to be easier to show that the distance to $H_A \cap \mathbb{T}_x$ is small, where \mathbb{T}_x is some two-dimensional cone. For this we will need Lemma 5.5.

The following is fairly classical result about first passage percolation with a minor twist due to the conditioning on the edges in A , we will outline the main idea of the proof while skipping a topological argument. To get a fully detailed proof of the topological argument, we refer the reader to the proof of Theorem 1.4 in [11].

Lemma 5.1. *Set $A = B^E(x, r)$ and $y, z \in \mathbb{Z}^d \setminus B(x, r - 1)$, there exists a non-increasing function $\alpha_1 : [0, 1] \rightarrow [0, 1]$ such that for $\varepsilon < \varepsilon_1$*

$$\mathbf{P}_{1-\varepsilon} \left[y \stackrel{\omega^{A,0}}{\leftrightarrow} z, d_{\omega^{A,0}}(y, z) \geq n + 2d_{\mathbb{Z}^d \setminus B(x, r-1)}(y, z) \right] \leq 2\alpha_1(\varepsilon)^{n+d_{\mathbb{Z}^d \setminus B(x, r-1)}(y, z)},$$

and

$$\mathbf{P}_{1-\varepsilon} \left[y \stackrel{\omega^{A,0}}{\leftrightarrow} z, d_{\omega^{A,0}}(y, z) \geq n + 2d_{\mathbb{Z}^d}(y, z) + 4dr \right] \leq 2\alpha_1(\varepsilon)^{n+d_{\mathbb{Z}^d}(y, z)},$$

where ε_1 and $\alpha_1(\cdot)$ depend only on d and $\lim_{\varepsilon \rightarrow 0} \alpha_1(\varepsilon) = 0$.

The main tool needed to prove Lemma 5.1 is a result of stochastic domination from [18]. We recall that a family $\{Y_u, u \in \mathbb{Z}^d\}$ of random variables is said to be k -dependent if for every $a \in \mathbb{Z}^d$, Y_a is independent of $\{Y_u : \|u - a\|_1 \geq k\}$.

Proposition 5.1. *Let d, k be positive integers. There exists a non-decreasing function $\alpha' : [0, 1] \rightarrow [0, 1]$ satisfying $\lim_{\tau \rightarrow 1} \alpha'(\tau) = 1$, such that the following holds: if $Y = \{Y_u, u \in \mathbb{Z}^d\}$ is a k -dependent family of random variables satisfying*

$$\text{for all } u \in \mathbb{Z}^d, \quad P(Y_u = 1) \geq \tau,$$

then $P_Y \succ (\alpha'(\tau)\delta_1 + (1 - \alpha'(\tau))\delta_0)^{\otimes \mathbb{Z}^d}$, where “ \succ ” means stochastically dominated.

Two vertices u, v are $*$ -neighbours if $\|u - v\|_\infty = 1$, this topology naturally induces a notion of $*$ -connected component on vertices.

Let us say that a vertex $u \in \mathbb{Z}^d$ is ω^A -wired if all edges $[s, t] \in E(\mathbb{Z}^d)$ with $\|u - s\|_\infty \leq 1$ and $\|u - t\|_\infty \leq 1$ are open in $\omega^{A,1}$ (recall that $A = B^E(x, r)$), otherwise it is called ω^A -unwired.

We say that a vertex $u \in \mathbb{Z}^d \setminus B(x, r - 1)$ is ω^A -strongly-wired, if all $y \in \mathbb{Z}^d \setminus B(x, r - 1)$ such that $\|u - y\|_\infty \leq 2$ are ω^A -wired, otherwise u is called ω^A -weakly-wired. It is plain that $\mathbf{1}\{u \text{ is } \omega^A\text{-strongly-wired}\}$ defines a γ_1 -dependent site percolation where γ_1 depends only on d . We can thus use Proposition 5.1 with this family of random variables since we have

$$\text{for all } u \in \mathbb{Z}^d, \quad \mathbf{P}_{1-\varepsilon}[\mathbf{1}\{u \text{ is } \omega^A\text{-strongly-wired}\} = 1] \geq (1 - \varepsilon)^{\gamma_1},$$

and that $\lim_{\varepsilon \rightarrow 0} (1 - \varepsilon)^{\gamma_1} = 1$. This yields a function $\alpha'(\cdot)$ which solely depends on d .

Proof. Let γ be one of the shortest path in $\mathbb{Z}^d \setminus B(x, r - 1)$ connecting y to z . For $u \in \mathbb{Z}^d \setminus B(x, r - 1)$, we define $V(u)(\omega^A)$ to be the $*$ -connected component of the ω^A -unwired vertices of u and

$$V(\omega^A) = \bigcup_{u \in \gamma} V(u)(\omega^A).$$

Since y and z are connected in $\omega^{A,0}$, a topological argument (see Section 3 of [11] for details) proves there is an $\omega^{A,0}$ -open path \mathcal{P} from y to z using only vertices in $\gamma \cup (V(\omega^{A,0}) + \{-2, -1, 0, 1, 2\}^d)$. On the event $d_{\omega^{A,0}}(y, z) \geq n + 2d_{\mathbb{Z}^d \setminus B(x, r-1)}(y, z)$, this path \mathcal{P} has $m \geq n + 2d_{\mathbb{Z}^d \setminus B(x, r-1)}(y, z) + 1$ vertices and all vertices which are not in γ are ω^A -weakly-wired thus there are at least $m - d_{\mathbb{Z}^d \setminus B(x, r-1)}(y, z) - 1$ of them .

Since there are at most $(2d)^k$ paths of length k in $\mathbb{Z}^d \setminus B(x, r - 1)$ we get, through a straightforward counting argument, that

$$\begin{aligned} & \mathbf{P}_{1-\varepsilon} \left[y \stackrel{\omega^{A,0}}{\longleftrightarrow} z, d_{\omega^{A,0}}(y, z) \geq n + d_{\mathbb{Z}^d \setminus B(x, r-1)}(y, z) \right] \\ & \leq \sum_{m \geq n + 2d_{\mathbb{Z}^d \setminus B(x, r-1)}(y, z) + 1} (2d)^m (1 - \alpha'((1 - \varepsilon)^{\gamma_1}))^{m - d_{\mathbb{Z}^d \setminus B(x, r-1)}(y, z) - 1} \\ & \leq \sum_{m \geq n + 2d_{\mathbb{Z}^d \setminus B(x, r-1)}(y, z) + 1} ((2d)^3 (1 - \alpha'((1 - \varepsilon)^{\gamma_1})))^{m - d_{\mathbb{Z}^d \setminus B(x, r-1)}(y, z) - 1}, \end{aligned}$$

where $\alpha'(\cdot)$ is given by Proposition 5.1 and verifies $\lim_{\varepsilon \rightarrow 0} 1 - \alpha'((1 - \varepsilon)^{\gamma_1}) = 0$. Thus, the first part of the proposition is verified with $\alpha_1(\varepsilon) := 1 - \alpha'((1 - \varepsilon)^{\gamma_1})$ and ε_1 small enough so that $1 - \alpha'((1 - \varepsilon_1)^{\gamma_1}) \leq (2d)^{-3}/2$.

The second part is a consequence of

$$d(y, z) \leq d_{\mathbb{Z}^d \setminus B(x, r-1)}(y, z) \leq d(y, z) + 2dr.$$

□

An easy consequence is the following tail estimate on M_A (defined at (4.2)).

Lemma 5.2. *Set $A = B^E(x, r)$, there exists a non-increasing function $\alpha_1 : [0, 1] \rightarrow [0, 1]$ such that for $\varepsilon < \varepsilon_1$*

$$\mathbf{P}_{1-\varepsilon}[M_A \geq n + 4dr] \leq C_3 r^{2d} \alpha_1(\varepsilon)^n,$$

where C_3 , ε_1 and $\alpha_1(\cdot)$ depend only on d and $\lim_{\varepsilon \rightarrow 0} \alpha_1(\varepsilon) = 0$. The function $\alpha_1(\cdot)$ is the same as in Lemma 5.1.

Proof. Since $|\partial A| \leq \rho_d r^d$, we have

$$\begin{aligned} & \mathbf{P}_{1-\varepsilon}[M_A \geq n + 4dr] \\ & \leq (\rho_d r^d)^2 \max_{a,b \in \partial A} \mathbf{P}_{1-\varepsilon} \left[a \stackrel{\omega^{A,0}}{\leftrightarrow} b, d_{\omega^{A,0}}(a,b) \geq n + 4dr \right] \leq \gamma_1 r^{2d} \alpha_1(\varepsilon)^n, \end{aligned}$$

where we used Lemma 5.1 since $d_{\mathbb{Z}^d \setminus B(x,r-1)}(a,b) \leq 4dr$ for $a, b \in \partial A$. \square

A set of n edges F disconnecting x from infinity in \mathbb{Z} , that is any infinite simple path starting from x uses an edge of F , is called a Peierls' contour of size n . Asymptotics on the number μ_n of Peierls' contours of size n have been intensively studied, see for example [15], we will use the following bound proved in [21] and cited in [15],

$$\mu_n \leq 3^n.$$

This enables us to prove the following tail estimate on T_A (defined at (4.3)).

Lemma 5.3. *Set $A = B^E(x, r)$, there exists a non-increasing function $\alpha_2 : [0, 1] \rightarrow [0, 1]$ such that for $\varepsilon < \varepsilon_2$*

$$\mathbf{P}_{1-\varepsilon}[T_A \geq n] \leq C_4 r^d \alpha_2(\varepsilon)^n,$$

where C_4 , ε_2 and $\alpha_2(\cdot)$ depend only on d and $\lim_{\varepsilon \rightarrow 0} \alpha_2(\varepsilon) = 0$.

Proof. First we notice that for $n \geq 1$,

$$\mathbf{P}_{1-\varepsilon}[T_A \geq n] \leq \rho_d r^d \max_{a \in \partial A} \mathbf{P}_{1-\varepsilon} \left[a \notin K_\infty(\omega^{A,0}), \left| \partial_E K^{\omega^{A,0}}(a) \right| \geq n \right].$$

For any $a \in \partial A$ such that $a \notin K_\infty(\omega^{A,0})$, we have that $\partial_E K^{\omega^{A,0}}(a)$ is a finite Peierls' contour of size $\left| \partial_E K^{\omega^{A,0}}(a) \right|$ surrounding a which has to be closed in $\omega^{A,0}$.

Because A is a ball at least half of the edges of $\partial_E K^{\omega^{A,0}}(a)$ have to be closed in ω as well. Indeed, take $[x, y] \in A \cap \partial_E K^{\omega^{A,0}}(a)$ and denote x its endpoint in $K^{\omega^{A,0}}(a)$, then by definition of a Peierls' contour there is $i \geq 0$ such that $[x + i(x - y), x + (i + 1)(x - y)]$ is in $\partial_E K^{\omega^{A,0}}(a)$, let $i_0(x, y)$ be the smallest one. If $[x + i_0(x, y)(x - y), x + (i_0(x, y) + 1)(x - y)]$ were in A , since A is a ball all edges between x and $x + i_0(x, y)(x - y)$ would too. This would imply that all edges adjacent to y are in A which would contradict the fact that y is connected to $a \in \partial A$ in $\omega^{A,0}$. See Figure 4 for a two dimensionnal drawing.

Hence

$$\psi : \begin{cases} A \cap \partial_E K^{\omega^{A,0}}(a) & \rightarrow \partial_E K^{\omega^{A,0}}(a) \setminus A \\ [x, y] & \mapsto [x + i_0(x, y)(x - y), x + (i_0(x, y) + 1)(x - y)], \end{cases}$$

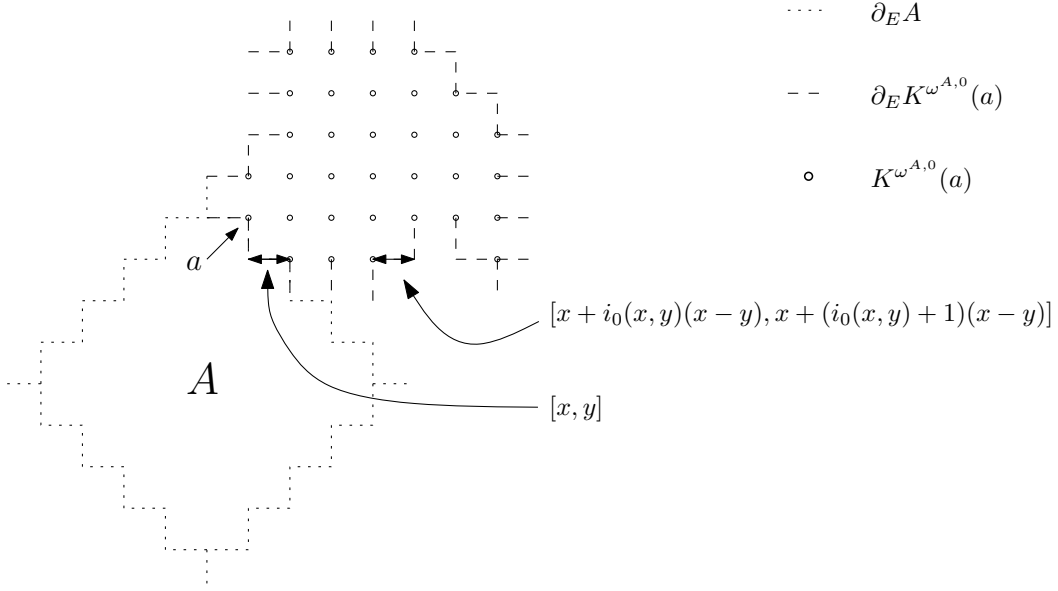

FIGURE 4. Half of the edges of $\partial_E K^{\omega^{A,0}}(a)$ have to be closed in ω

is an injection so that at least half of the edges of $\partial_E K^{\omega^{A,0}}(a)$ are indeed closed in ω . There are at most $\binom{m}{\lceil m/2 \rceil} \leq \gamma_1 2^m$ ways of choosing those edges, thus we get for any $a \in \partial A$

$$\begin{aligned} \mathbf{P}_{1-\varepsilon} \left[a \notin K_\infty(\omega^{A,0}), \left| \partial_E K^{\omega^{A,0}}(a) \right| \geq n \right] &\leq \sum_{m \geq n} \binom{m}{\lceil m/2 \rceil} \mu(n) \varepsilon^{m/2} \\ &\leq \gamma_1 \sum_{m \geq n} 6^m \varepsilon^{m/2} \leq \gamma_2 \varepsilon^{n/2}, \end{aligned}$$

for ε such that $\varepsilon^{1/2} < 1/12$. \square

A direct consequence of (5.1), Lemma 5.2 and Lemma 5.3 is the following tail estimate on L_A^1 , defined below (4.4)

Lemma 5.4. *Set $A = B^E(x, r)$, there exists a non-increasing function $\alpha_3 : [0, 1] \rightarrow [0, 1]$ such that for $\varepsilon < \varepsilon_3$*

$$\mathbf{P}_{1-\varepsilon} [L_A^1 \geq n + C_5 r] \leq C_6 r^{2d} \alpha_3(\varepsilon)^n,$$

where C_5, C_6, ε_3 and $\alpha_3(\cdot)$ depend only on d and $\lim_{\varepsilon \rightarrow 0} \alpha_3(\varepsilon) = 0$.

Recalling the definition of H_A above (4.5), let us introduce

$$(5.2) \quad L'_A(\omega) = \begin{cases} \infty & \text{if } \forall y \in \partial A, y \notin K_\infty(\omega^{A,0}) \\ d_{\omega^{A,0}}(\partial A, H_A(\omega)) & \text{otherwise,} \end{cases}$$

it is plain that $L_A \leq L'_A$.

We need one more estimate before turning to the tail of L'_A (and thus L_A). Define the cone $\mathbb{T} = \{ae^{(1)} + be^{(2)}, 0 \leq b \leq a/2 \text{ for } a, b \in \mathbb{N}\}$. It is a standard percolation result that $p_c(\mathbb{T}) < 1$ (see Section 11.5 of [12]) and well-known that the infinite cluster is unique. We denote $K_\infty^\mathbb{T}(\omega)$ the unique infinite cluster of \mathbb{T} induced by the percolation ω , provided $\varepsilon < 1 - p_c(\mathbb{T})$.

Lemma 5.5. *There exists a non-increasing function $\alpha_4 : [0, 1] \rightarrow [0, 1]$ so that for $\varepsilon < \varepsilon_4$*

$$\mathbf{P}_{1-\varepsilon} \left[d_{\mathbb{T}}(0, K_\infty^\mathbb{T}(\omega)) \geq 1 + n \right] \leq C_7 \alpha_4(\varepsilon)^n,$$

where $C_7, \alpha_4(\cdot)$ depend only on d and $\lim_{\varepsilon \rightarrow 0} \alpha_4(\varepsilon) = 0$.

Proof. Choose $\varepsilon < 1 - p_c(\mathbb{T})$, so that $K_\infty^\mathbb{T}(\omega)$ is well defined almost surely. We emphasize that the following reasoning is in essence two dimensional, so we are allowed to use duality arguments (see [12], Section 11.2). We recall that an edge of the dual lattice (i.e. of $\mathbb{Z}^2 + (1/2, 1/2)$) is called closed when it crosses a closed edge of the original lattice.

If $d_{\mathbb{T}}(0, K_\infty^\mathbb{T}(\omega)) = n + 1$, then let x be a point for which this distance is reached, x is one among at most $n + 2$ possible points. Consider an edge $e = [x, y]$ where $d_{\mathbb{T}}(0, y) = n$, let e' denote the corresponding edge in the dual lattice. From each endpoint of this edge there is a closed path in the dual lattice which has to cross out of \mathbb{T} , so that the sum of the lengths of these two paths is at least $n - 1$. Thus there has to be a closed path \mathcal{P} in the dual lattice of length $m \geq \lfloor (n + 1)/2 \rfloor$ (including e' in the largest of the previous two paths) starting from one of the endpoints of e' and crossing out of \mathbb{T} (see Figure 5).

Thus since there are at most 4^m paths of length m , we get for ε small enough

$$\mathbf{P}_{1-\varepsilon} \left[d_{\mathbb{T}}(0, K_\infty^\mathbb{T}(\omega)) = 1 + n \right] \leq 2(n + 2) \sum_{m \geq \frac{n}{2}} 4^m \varepsilon^m \leq 4(n + 2)(4\varepsilon)^{n/2},$$

and the result follows from $n + 2 \leq 2^{n+1}$ since

$$\mathbf{P}_{1-\varepsilon} \left[d_{\mathbb{T}}(0, K_\infty^\mathbb{T}(\omega)) \geq 1 + n \right] \leq \sum_{m \geq n} 4(n + 2)(4\varepsilon)^{n/2} \leq \gamma_1 (4\varepsilon^{1/2})^n.$$

□

Now we turn to the study of the asymptotics of L_A .

Proposition 5.2. *Set $A = B^E(x, r)$, there exists a non-increasing function $\alpha : [0, 1] \rightarrow [0, 1]$ so that for $\varepsilon < \varepsilon_0$*

$$\mathbf{P}_{1-\varepsilon} [L_A \geq n + C_8 r] \leq C_9 r^{2d} n \alpha(\varepsilon)^n,$$

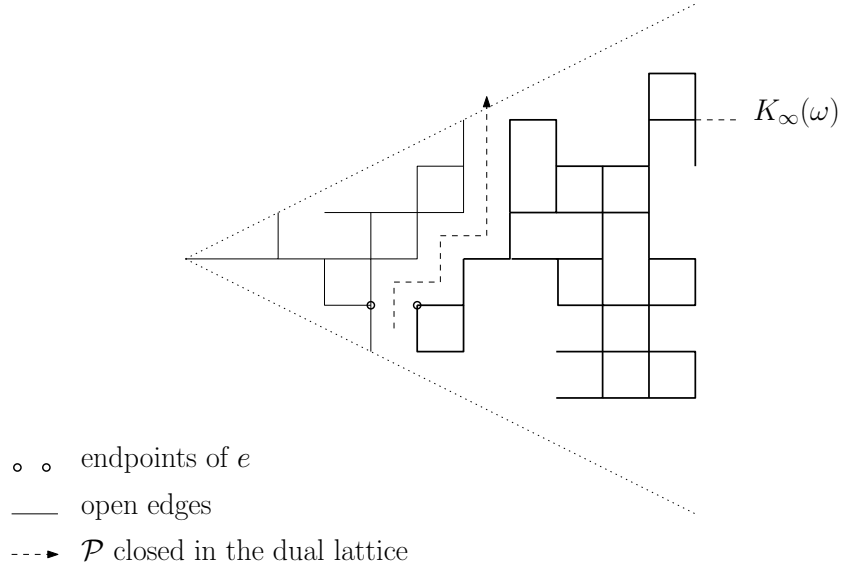

FIGURE 5. The closed path in the dual lattice

where C_8, C_9, ε_0 and $\alpha(\cdot)$ depend only on d and ℓ and $\lim_{\varepsilon \rightarrow 0} \alpha(\varepsilon) = 0$.

Proof. Let us notice that two cases emerge. First let us consider that we are on the event $\{\partial A \cap K_\infty = \emptyset\}$ in which case we have

$$L_A(\omega) = \min\{n \geq 0, \partial A \text{ is not connected to } \partial B(x, n)\} \leq r + T_A(\omega) \leq L_A^1,$$

hence because of Lemma 5.4 we have for $C_8 > C_5$

$$(5.3) \quad \mathbf{P}[\partial A \cap K_\infty = \emptyset, L_A \geq n + C_8 r] \leq C_6 r^{2d} \alpha_3(\varepsilon)^n.$$

We are now interested in the case where $\partial A \cap K_\infty \neq \emptyset$. It is sufficient to give an upper bound for L'_A (defined at (5.2)) since $L_A \leq L'_A$. Set $\varepsilon < \varepsilon_1 \wedge \varepsilon_2 \wedge \varepsilon_3 \wedge \varepsilon_4$, we notice using Lemma 5.4 that

$$(5.4) \quad \begin{aligned} & \mathbf{P}_{1-\varepsilon}[\partial A \cap K_\infty \neq \emptyset, L'_A \geq n + C_8 r] \\ & \leq \mathbf{P}_{1-\varepsilon}[L_A^1 \geq n/(8\eta d) + C_5 r] \\ & \quad + \mathbf{P}_{1-\varepsilon}[\partial A \cap K_\infty \neq \emptyset, L_A^1 \leq n/(8\eta d) + C_5 r, L'_A \geq n + C_8 r] \\ & \leq \mathbf{P}_{1-\varepsilon}[\partial A \cap K_\infty \neq \emptyset, L_A^1 \leq n/(8\eta d) + C_5 r, L'_A \geq n + C_8 r] \\ & \quad + C_6 r^{2d} \alpha_1(\varepsilon)^{n/(8\eta d)}. \end{aligned}$$

We denote h_m^x the hyperplane $\{y, y \cdot \vec{\ell} \geq x \cdot \vec{\ell} + m\}$, we have

$$(5.5) \quad \begin{aligned} & \mathbf{P}_{1-\varepsilon}[\partial A \cap K_\infty \neq \emptyset, L_A^1 \leq n/(8\eta d) + C_5 r, L'_A \geq n + C_8 r] \\ & \leq \mathbf{P}_{1-\varepsilon}[\partial A \cap K_\infty \neq \emptyset, d_{\omega^{A,0}}(\partial A, h_{n/(8d)+\eta C_5 r}^x) \geq n + C_8 r] \end{aligned}$$

$$\leq |\partial A| \max_{y \in \partial A} \mathbf{P}_{1-\varepsilon} \left[y \stackrel{\omega^{A,0}}{\leftrightarrow} \infty, d_{\omega^{A,0}}(y, h_{n/(8d)+\gamma_1 r}^x) \geq n + C_8 r \right].$$

Set $y \in \partial A$ and let us denote γ_2 a constant which will be chosen large enough. Using the uniqueness of the infinite cluster we get

$$(5.6) \quad \begin{aligned} & \mathbf{P}_{1-\varepsilon} \left[d_{\mathbb{Z}^d} \left(y, K_\infty(\omega^{A,0}) \cap h_{n/(8d)+\gamma_1 r}^x \cap \{y + \mathbb{T}\} \right) \geq n/2 + \gamma_2 r \right] \\ & \leq \mathbf{P}_{1-\varepsilon} \left[d_{y+\mathbb{T}} \left(y, K_\infty^{y+\mathbb{T}}(\omega^{A,0}) \cap h_{n/(8d)+\gamma_1 r}^x \right) \geq n/2 + \gamma_2 r \right] \\ & \leq \mathbf{P}_{1-\varepsilon} \left[d_{y+\mathbb{T}} \left(y, K_\infty^{y+\mathbb{T}}(\omega) \cap h_{n/(8d)+\gamma_1 r}^x \right) \geq n/2 + \gamma_2 r \right], \end{aligned}$$

where we have to suppose that $\gamma_2 \geq 2$ for the last inequality. Indeed then $d_{y+\mathbb{T}}(y, K_\infty^{y+\mathbb{T}}(\omega)) = d_{y+\mathbb{T}}(y, K_\infty^{y+\mathbb{T}}(\omega^{A,0}))$ on the event $\{d_{y+\mathbb{T}}(y, K_\infty^{y+\mathbb{T}}(\omega)) \geq \gamma_2 r\}$ since the distance to the infinite cluster is greater than the radius of A .

Moreover since $e^{(1)} \cdot \vec{\ell} \geq 1/\sqrt{d}$, we notice that

$$\min_{y \in h_m^x \cap \mathbb{T}} d_{x+\mathbb{T}}(x, y) \geq 2\sqrt{d}m.$$

Applying this for $m = n/(8d) + \gamma_1 r$, we get that

$$(5.7) \quad \begin{aligned} & \mathbf{P}_{1-\varepsilon} \left[d_{y+\mathbb{T}} \left(y, K_\infty^{y+\mathbb{T}}(\omega) \cap h_{n/(8d)+\gamma_1 r}^y \right) \geq n/2 + \gamma_2 r \right] \\ & \leq \mathbf{P}_{1-\varepsilon} \left[d_{y+\mathbb{T}} \left(y, K_\infty^{y+\mathbb{T}}(\omega) \right) \geq n/2 + \gamma_2 r \right], \end{aligned}$$

where γ_2 is large enough so that $2\sqrt{d}(n/(8d) + \gamma_1 r) \leq n/2 + \gamma_2 r$.

The equations (5.6) and (5.7) used with Lemma 5.5 yield that for γ_3 large enough and any $y \in \partial A$,

$$\mathbf{P}_{1-\varepsilon} \left[d_{\mathbb{Z}^d} \left(y, K_\infty(\omega^{A,0}) \cap h_{n/(8d)+\gamma_1 r}^y \cap \{y + \mathbb{T}\} \right) \geq n/2 + \gamma_3 r \right] \leq \gamma_4 \alpha_4(\varepsilon)^{n/2}.$$

If we use Lemma 5.1 and the previous inequality, for C_8 large enough so that $n + C_8 r \geq 2(n/2 + \gamma_3 r) + 4dr$,

$$(5.8) \quad \begin{aligned} & \mathbf{P}_{1-\varepsilon} \left[\partial A \cap K_\infty \neq \emptyset, d_{\omega^{A,0}} \left(y, h_{n/(8d)+\gamma_1 r}^y \right) \geq n + C_8 r \right] \\ & \leq \mathbf{P}_{1-\varepsilon} \left[d_{\mathbb{Z}^d} \left(y, K_\infty(\omega^{A,0}) \cap h_{n/(8d)+\gamma_1 r}^y \cap \{y + \mathbb{T}\} \right) \geq n/2 + \gamma_3 r \right] \\ & + \sum_{z \in \partial B_{\mathbb{Z}^d}(y, [n/2+\gamma_3 r]) \cap \{y+\mathbb{T}\}} \mathbf{P}_{1-\varepsilon} \left[z \stackrel{\omega^{A,0}}{\leftrightarrow} y, d_{\omega^{A,0}}(z, y) \geq 2d(y, z) + 4dr \right] \\ & \leq \gamma_4 \alpha_4(\varepsilon)^{n/2} + \gamma_5 (n + \gamma_3 r) \alpha_1(\varepsilon)^{n/2} \leq \gamma_6 r n \alpha_5(\varepsilon)^n, \end{aligned}$$

where $\varepsilon < \varepsilon_5$ depends only on d and ℓ for some $\alpha_5(\cdot)$ such that $\lim_{\varepsilon \rightarrow 0} \alpha_5(\varepsilon) = 0$.

Adding up (5.4), (5.5) and (5.8) we get

$$\mathbf{P}_{1-\varepsilon} [\partial A \cap K_\infty \neq \emptyset, L'_A \geq n + C_8 r] \leq \gamma_7 n r^d (\alpha_1(\varepsilon))^{n/(8nd)} + \alpha_5(\varepsilon)^n$$

$$\leq \gamma_8 n r^d \alpha(\varepsilon)^n,$$

where $\alpha(\varepsilon) := \alpha_1(\varepsilon)^{1/(8nd)} + \alpha_5(\varepsilon)$. As we have $\lim_{\varepsilon \rightarrow 0} \alpha(\varepsilon) = 0$, this last equation and (5.3) completes the proof of Proposition 5.2. \square

Essentially by replacing $(\mathbb{Z}^d, E(\mathbb{Z}^d))$ by $(\mathbb{Z}^d, E(\mathbb{Z}^d \setminus [z, z + e]))$ and ω by $\omega^{z,e}$ along with some minor modifications we obtain

Proposition 5.3. *Set $A = B^E(x, r)$, $z \in \mathbb{Z}^d$ and $e \in \nu$, there exists a non-increasing function $\alpha : [0, 1] \rightarrow [0, 1]$ so that for $\varepsilon < \varepsilon_0$*

$$\mathbf{P}_{1-\varepsilon}[L_A(\omega^{z,e}) \geq n + C_8 r] \leq C_9 r^d n \alpha(\varepsilon)^n,$$

where C_8, C_9, ε_0 and $\alpha(\cdot)$ depend only on d and ℓ and $\lim_{\varepsilon \rightarrow 0} \alpha(\varepsilon) = 0$.

Here we assume without loss of generality that the constants are the same as in Proposition 5.2.

6. CONTINUITY OF THE SPEED AT HIGH DENSITY

We now have the necessary tools to study the central quantities which appeared in (3.2).

Proposition 6.1. *For $0 < \varepsilon < \varepsilon_5$, $A \in \{0, 1\}^\nu \setminus \nu$ and $\delta \geq 1/2$*

$$\frac{\mathbf{E}_{1-\varepsilon}[\mathbf{1}\{\mathcal{I}(\omega^{z,A})\} G_\delta^{\omega^{z,A}}(0, z)]}{\mathbf{E}_{1-\varepsilon}[\mathbf{1}\{\mathcal{I}\} G_\delta^\omega(0, z)]} < C,$$

where C and ε_5 depend only on ℓ and d .

This section is devoted to the proof of this proposition. We have

$$\begin{aligned} \mathbf{E}[\mathbf{1}\{\mathcal{I}\} G_\delta^\omega(0, z)] &\geq \mathbf{E}[\mathbf{1}\{\mathcal{C}(z) = \emptyset\} \mathbf{1}\{\mathcal{I}\} G_\delta^\omega(0, z)] \\ &= \mathbf{E}[\mathbf{1}\{\mathcal{C}(z) = \emptyset\} \mathbf{1}\{\mathcal{I}(\omega^{z,\emptyset})\} G_\delta^{\omega^{z,\emptyset}}(0, z)] \\ &= \mathbf{P}[\mathcal{C}(z) = \emptyset] \mathbf{E}[\mathbf{1}\{\mathcal{I}(\omega^{z,\emptyset})\} G_\delta^{\omega^{z,\emptyset}}(0, z)]. \end{aligned}$$

For $\varepsilon < 1/4 \leq 1 - p_c(d)$, we have $\mathbf{P}[\mathcal{C}(z) = \emptyset] > \gamma_1 > 0$ for γ_1 independent of ε , so that

$$(6.1) \quad \mathbf{E}[\mathbf{1}\{\mathcal{I}\} G_\delta^\omega(0, z)] \geq \gamma_1 \mathbf{E}[\mathbf{1}\{\mathcal{I}(\omega^{z,\emptyset})\} G_\delta^{\omega^{z,\emptyset}}(0, z)].$$

Now we want a similar upper bound for the numerator of Proposition 6.1. Let $A \in \{0, 1\}^\nu \setminus \nu$, then by (2.5) and (4.1) we obtain

$$(6.2) \quad \frac{1}{\kappa_1} e^{2\lambda z \cdot \vec{\ell}} \frac{1}{\delta} \leq \pi^{\omega^{z,A}(\delta)}(z) \leq \kappa_1 e^{2\lambda z \cdot \vec{\ell}} \frac{1}{\delta}.$$

This equation combined with Lemma 4.1 yields

$$(6.3) \quad \mathbf{E} \left[\mathbf{1} \{ \mathcal{I}(\omega^{z,A}) \} G_\delta^{\omega^{z,A}}(0, z) \right] \\ \leq \frac{\kappa_1 e^{2\lambda z \cdot \vec{\ell}}}{\delta} \mathbf{E} \left[\mathbf{1} \{ \mathcal{I}(\omega^{z,A}) \} P_0^{\omega^{z,A}} [T_z < \tau_\delta] R^{\omega^{z,A}}(z \leftrightarrow \Delta) \right].$$

If $z \notin K_\infty(\omega^{z,A})$ then $P_0^{\omega^{z,A}} [T_z < \tau_\delta] = 0$. Otherwise we can apply Proposition 4.2 to get

$$(6.4) \quad R_\delta^{\omega^{z,A}}(z \leftrightarrow \Delta) \leq R_\delta^{\omega^{z,\emptyset}}(z \leftrightarrow \Delta) + C_1 L_z(\omega)^{C_2} e^{2\lambda(L_z(\omega) - z \cdot \vec{\ell})},$$

where we used notations from (4.5).

Moreover we notice that $P_0^{\omega^{z,A}} [T_z < \tau_\delta] \leq P_0^{\omega^{z,\emptyset}} [T_z < \tau_\delta]$ and $\mathbf{1} \{ \mathcal{I}(\omega^{z,A}) \} \leq \mathbf{1} \{ \mathcal{I}(\omega^{z,\emptyset}) \}$. Then inserting (6.4) into (6.3), using Lemma 4.1 and (6.2) we get since $\delta \geq 1/2$

$$(6.5) \quad \mathbf{E} \left[\mathbf{1} \{ \mathcal{I} \} G_\delta^\omega(0, z) | \mathcal{C}(z) = A \right] \leq \kappa_1^2 \mathbf{E} \left[\mathbf{1} \{ \mathcal{I}(\omega^{z,\emptyset}) \} G_\delta^{\omega^{z,\emptyset}}(0, z) \right] \\ + 2C_1 \kappa_1 \mathbf{E} \left[\mathbf{1} \{ \mathcal{I}(\omega^{z,\emptyset}) \} P_0^{\omega^{z,\emptyset}} [T_z < \tau_\delta] L_z(\omega)^{C_2} e^{2\lambda L_z(\omega)} \right].$$

Now we want to prove that the even though hitting probabilities depend on the whole environment their correlation with “local” quantities are weak in some sense. Let us now make explicit the two properties which are crucial for what we call “local quantity” which are the second property of Proposition 4.1 and that arbitrarily large exponential moments for ε small enough, like those obtained in Proposition 5.2. We obtain the following decorrelation lemma.

Lemma 6.1. *Set $\delta \geq 1/2$, then*

$$\mathbf{E} \left[\mathbf{1} \{ \mathcal{I}(\omega^{z,\emptyset}) \} P_0^{\omega^{z,\emptyset}} [T_z < \tau_\delta] L_z(\omega)^{C_2} e^{2\lambda L_z(\omega)} \right] \\ \leq C_{10} \mathbf{E} \left[\mathbf{1} \{ \mathcal{I}(\omega^{z,\emptyset}) \} P_0^{\omega^{z,\emptyset}} [T_z < \tau_\delta] \right] \mathbf{E} \left[L_z(\omega)^{C_{11}} e^{C_{12} L_z(\omega)} \right],$$

where C_{10} , C_{11} and C_{12} depend only on d and ℓ .

Proof. First let us notice that the third property in Proposition 4.1 implies that L_z is finite. Set $k \in \mathbb{N}^*$, recall that the event $\{L_z = k\}$ depends only on edges in $B^E(z, k)$ by the second property of Proposition 4.1.

We have $\mathbf{1} \{ \mathcal{I}(\omega^{z,\emptyset}) \} \leq \mathbf{1} \{ \partial B(z, k) \leftrightarrow \infty \}$. Assume first that $0 \notin B(z, k)$,

$$(6.6) \quad \mathbf{E} \left[\mathbf{1} \{ \mathcal{I}(\omega^{z,\emptyset}) \} P_0^{\omega^{z,\emptyset}} [T_z < \tau_\delta] L_z(\omega)^{C_2} e^{2\lambda L_z(\omega)} | L_z = k \right] \\ = k^{C_2} e^{2\lambda k} \mathbf{E} \left[\mathbf{1} \{ \mathcal{I}(\omega^{z,\emptyset}) \} P_0^{\omega^{z,\emptyset}} [T_z < \tau_\delta] | L_z = k \right]$$

$$\leq \rho_d k^{\gamma_1} e^{2\lambda k} \mathbf{E} \left[\mathbf{1}\{\partial B(z, k) \leftrightarrow \infty\} \max_{x \in \partial B(z, k)} P_0^\omega [T_x < \tau_\delta, T_x = T_{\partial B(z, k)}] \right],$$

indeed $|\partial B(z, k)| \leq \rho_d k^d$, here we implicitly used that $0 \notin B(z, k)$. Now the integrand of the last term does not depend on the configuration of the edges in $B^E(z, k)$.

We denote $x_0(\omega)$ a vertex of $\partial B(z, k)$ connected in ω to infinity without using edges of $B^E(z, k)$ and accordingly we introduce $\{a \Leftrightarrow b\}$ the event that a is connected in ω to b using no edges of $B^E(z, k)$. Again we point out that the random variable $x_0(\omega)$ is measurable with respect to $\{\omega(e), e \notin B^E(z, k)\}$.

Let us set $x_1(\omega)$ the point for which the maximum in the last line of (6.6) is achieved, this random point also depends only on the set of configurations in $E(\mathbb{Z}^d) \setminus B^E(z, k)$, the same is true for $P_0^\omega [T_{x_0} < \tau_\delta, T_{x_0} = T_{\partial B(z, k)}]$.

In case there are multiple choices the definition of the random variables $x_0(\omega)$ or $x_1(\omega)$, we pick one of the choice according to some predetermined order on the vertices of \mathbb{Z}^d . In case $x_0(\omega)$ or $x_1(\omega)$ are not properly defined, i.e. when $\partial B(z, k)$ is not connected to infinity, we set $x_0(\omega) = z$. With this definition we have $\{x_0 \Leftrightarrow \infty\} = \{\partial B(z, k) \leftrightarrow \infty\}$.

The definition of x_1 implies that

$$x_1(\omega) \Leftrightarrow 0 \text{ if } \max_{x \in \partial B(z, k)} P_0^\omega [T_x < \tau_\delta, T_x = T_{\partial B(z, k)}] > 0.$$

Now let \mathcal{P}_0 be a path of k edges in \mathbb{Z}^d between z and x_0 and \mathcal{P}_1 a path of k edges in \mathbb{Z}^d between z and x_1 . As those path are contained in $B^E(z, k)$, we get

(6.7)

$$\begin{aligned} & \mathbf{E} \left[\mathbf{1}\{\partial B(z, k) \leftrightarrow \infty\} \mathbf{1}\{x_1 \Leftrightarrow 0\} P_0^\omega [T_{x_1} < \tau_\delta, T_{x_1} = T_{\partial B(z, k)}] \right] \\ &= \mathbf{E} \left[\mathbf{1}\{x_0 \Leftrightarrow \infty\} \mathbf{1}\{x_1 \Leftrightarrow 0\} P_0^\omega [T_{x_1} < \tau_\delta, T_{x_1} = T_{\partial B(z, k)}] | \mathcal{P}_0 \cup \mathcal{P}_1 \in \omega \right] \\ &\leq \frac{1}{\mathbf{P}[\mathcal{P}_0 \cup \mathcal{P}_1 \in \omega]} \mathbf{E} \left[\mathbf{1}\{\mathcal{P}_0 \cup \mathcal{P}_1 \in \omega\} \mathbf{1}\{x_0 \Leftrightarrow \infty\} \mathbf{1}\{x_1 \Leftrightarrow 0\} P_0^\omega [T_{x_1} < \tau_\delta] \right]. \end{aligned}$$

Then we see that since we have $\varepsilon < 1/2$

$$(6.8) \quad \mathbf{P}[\mathcal{P}_0 \cup \mathcal{P}_1 \in \omega] = (1 - \varepsilon)^{2k} \geq \frac{1}{4^k}.$$

Moreover, on the event $\mathcal{P}_0 \in \omega$, Markov's property yields

$$(\delta \kappa_0)^k P_0^\omega [T_{x_1} < \tau_\delta] \leq P_0^\omega [T_z < \tau_\delta].$$

Since $\delta \geq 1/2$,

$$(6.9) \quad \begin{aligned} & \mathbf{E} \left[\mathbf{1}\{\mathcal{P}_0 \cup \mathcal{P}_1 \in \omega\} \mathbf{1}\{x_0 \Leftrightarrow \infty\} \mathbf{1}\{x_1 \Leftrightarrow 0\} P_0^\omega [T_{x_1} < \tau_\delta] \right] \\ &\leq (2/\kappa_0)^k \mathbf{E} \left[\mathbf{1}\{\mathcal{P}_0 \cup \mathcal{P}_1 \in \omega\} \mathbf{1}\{x_0 \Leftrightarrow 0\} \mathbf{1}\{x_1 \Leftrightarrow \infty\} P_0^\omega [T_z < \tau_\delta] \right] \end{aligned}$$

$$\leq (2/\kappa_0)^k \mathbf{E} \left[\mathbf{1}\{\mathcal{I}\} P_0^\omega [T_z < \tau_\delta] \right],$$

since on $\mathbf{1}\{\mathcal{P}_0 \cup \mathcal{P}_1 \in \omega\} \mathbf{1}\{x_0 \Leftrightarrow 0\} \mathbf{1}\{x_1 \Leftrightarrow \infty\}$ we have $0 \leftrightarrow x_0 \leftrightarrow z \leftrightarrow x_1 \leftrightarrow \infty$ and which means that \mathcal{I} occurs.

Adding up (6.6), (6.7), (6.8), (6.9), noticing that $\mathbf{1}\{\mathcal{I}\} \leq \mathbf{1}\{\mathcal{I}(\omega^{z,\emptyset})\}$ and $P_0^\omega [T_z < \tau_\delta] \leq P_0^{\omega^{z,\emptyset}} [T_z < \tau_\delta]$, we get

$$(6.10) \quad \begin{aligned} & \mathbf{E} \left[\mathbf{1}\{\mathcal{I}(\omega^{z,\emptyset})\} P_0^{\omega^{z,\emptyset}} [T_z < \tau_\delta] L_z(\omega)^{C_2} e^{2\lambda L_z(\omega)} \mid L_z = k \right] \\ & \leq \rho_d k^{\gamma_1} (8e^{2\lambda}/\kappa_0)^k \mathbf{E} \left[\mathbf{1}\{\mathcal{I}(\omega^{z,\emptyset})\} P_0^{\omega^{z,\emptyset}} [T_z < \tau_\delta] \right]. \end{aligned}$$

Let us come back to the case where $0 \in B(z, k)$. We can obtain the same result by saying that $P_0^{\omega^{z,\emptyset}} [T_z < \tau_\delta] \leq 1$ in (6.6) and formally replacing $P_0^\omega [T_x < \tau_\delta, T_x = T_{\partial B(z,k)}]$ by 1 for any $x \in \partial B(z, k)$ and x_1 by 0 in the whole previous proof. The conclusion of this is that (6.10) holds in any case.

The result follows from an integration over all the events $\{L_z = k\}$ for $k \in \mathbb{N}$ since by (6.10), we obtain

$$\begin{aligned} & \mathbf{E} \left[\mathbf{1}\{\mathcal{I}(\omega^{z,\emptyset})\} P_0^{\omega^{z,\emptyset}} [T_z < \tau_\delta] L_z(\omega)^{C_2} e^{2\lambda L_z(\omega)} \right] \\ & \leq \mathbf{E} \left[\sum_{k=1}^{\infty} \mathbf{P}[L_z = k] \mathbf{E} \left[\mathbf{1}\{\mathcal{I}(\omega^{z,\emptyset})\} P_0^{\omega^{z,\emptyset}} [T_z < \tau_\delta] L_z(\omega)^{C_2} e^{2\lambda L_z(\omega)} \mid L_z = k \right] \right] \\ & \leq \rho_d \mathbf{E} \left[\sum_{k=1}^{\infty} \mathbf{P}[L_z = k] k^{\gamma_1} (8e^{2\lambda}/\kappa_0)^k \mathbf{E} \left[\mathbf{1}\{\mathcal{I}(\omega^{z,\emptyset})\} P_0^{\omega^{z,\emptyset}} [T_z < \tau_\delta] \right] \right] \\ & = \rho_d \mathbf{E} \left[L_z^{\gamma_1} (8e^{2\lambda}/\kappa_0)^{L_z} \right] \mathbf{E} \left[\mathbf{1}\{\mathcal{I}(\omega^{z,\emptyset})\} P_0^{\omega^{z,\emptyset}} [T_z < \tau_\delta] \right]. \end{aligned}$$

□

We can apply Proposition 5.2 to get that for $0 < \varepsilon < \varepsilon_6$

$$\mathbf{E} \left[L_z(\omega)^{C_{11}} e^{C_{12} L_z(\omega)} \right] \leq \sum_{k \geq 0} k^{C_{11}} e^{C_{12} k} \mathbf{P}[L_z \geq k] < C_{13} < \infty,$$

where ε_6 is such that $\alpha_0(\varepsilon_6) < e^{-C_{12}}/2$ and, as C_{13} , depends only on d and ℓ . Then recalling (6.5), using Lemma 6.1 with the previous equation we obtain

$$\begin{aligned} & \mathbf{E} \left[\mathbf{1}\{\mathcal{I}(\omega^{z,A})\} G_\delta^{\omega^{z,A}}(0, z) \right] \\ & \leq \kappa_1^2 \mathbf{E} \left[\mathbf{1}\{\mathcal{I}(\omega^{z,\emptyset})\} G_\delta^{\omega^{z,\emptyset}}(0, z) \right] + 2C_1 C_{10} C_{13} \kappa_1 \mathbf{E} \left[\mathbf{1}\{\mathcal{I}(\omega^{z,\emptyset})\} P_0^{\omega^{z,\emptyset}} [T_z < \tau_\delta] \right] \\ & \leq \gamma_2 \mathbf{E} \left[\mathbf{1}\{\mathcal{I}(\omega^{z,\emptyset})\} G_\delta^{\omega^{z,\emptyset}}(0, z) \right]. \end{aligned}$$

Using the preceding equation with (6.1) concludes the proof of Lemma 6.1. We are now able to prove the following

Proposition 6.2. *For any $d \geq 2$, $\varepsilon < 1 - p_c(d)$ and $\ell \in \mathbb{R}^d$ we have*

$$v_\ell(1 - \varepsilon) = d_\emptyset + O(\varepsilon).$$

Proof. First notice that

$$\mathbf{P}[\mathcal{C}(z) = \emptyset] = 1 + O(\varepsilon) \text{ and } \mathbf{P}[\mathcal{C}(z) \neq \emptyset] = O(\varepsilon).$$

using (3.1) and Lemma 6.1 we get for $\delta \geq 1/2$,

$$(6.11) \quad \widehat{d}_\delta^\varepsilon(z) = d_\emptyset \frac{\mathbf{E}_{1-\varepsilon} \left[\mathbf{1}\{\mathcal{I}\} \mathbf{1}\{\mathcal{C}(z) = \emptyset\} G_\delta^\omega(0, z) \right]}{\mathbf{E}_{1-\varepsilon} \left[\mathbf{1}\{\mathcal{I}\} G_\delta^\omega(0, z) \right]} + O(\varepsilon),$$

where the $O(\cdot)$ depends only on d and ℓ . But using Lemma 6.1 again yields

$$\left| \frac{\mathbf{E}_{1-\varepsilon} \left[\mathbf{1}\{\mathcal{I}\} \mathbf{1}\{\mathcal{C}(z) = \emptyset\} G_\delta^\omega(0, z) \right]}{\mathbf{E}_{1-\varepsilon} \left[\mathbf{1}\{\mathcal{I}\} G_\delta^\omega(0, z) \right]} - 1 \right| \leq O(\varepsilon),$$

and thus

$$\widehat{d}_\delta^\varepsilon(z) - d_\emptyset = O(\varepsilon),$$

where the $O(\cdot)$ depends only on d and ℓ . Recalling Proposition 3.3, we get

$$v_\ell(1 - \varepsilon) = d_\emptyset + O(\varepsilon).$$

□

7. DERIVATIVE OF THE SPEED AT HIGH DENSITY

Next we want to obtain the derivative of the velocity with respect to the percolation parameter.

In this section we fix $z \in \mathbb{Z}^d$. Using (3.1) with Proposition 6.1 we can get the first order of Kalikow's drift

$$(7.1) \quad d_\delta^{\widehat{\omega}}(z) - d_\emptyset = \varepsilon \left(\sum_{e \in \mathcal{V}} \frac{\mathbf{E}_{1-\varepsilon} [\mathbf{1}\{\mathcal{I}(\omega^{z,e})\} G_\delta^{\omega^{z,e}}(0, z)]}{\mathbf{E}_{1-\varepsilon} [\mathbf{1}\{\mathcal{I}(\omega)\} G_\delta^\omega(0, z)]} (d_e - d_\emptyset) \right) + O(\varepsilon^2),$$

where $O(\cdot)$ depends only on d and ℓ . The remaining issue is the dependence of the expectation with respect to ε .

7.1. Another perturbed environment of Kalikow. We can link the Green functions of two Markov operators P and P' , since for $n \geq 0$

$$(7.2) \quad G_\delta^{P'} = G_\delta^P + \sum_{k=1}^n \delta^k (G_\delta^P (P' - P))^k G_\delta^P + \delta^{n+1} (G_\delta^P (P' - P))^{n+1} G_\delta^{P'}.$$

In our case we close one edge which changes the transition probabilities at two sites, so that the previous formula applied for $n = 0$,

(7.3)

$$\begin{aligned} G_\delta^{\omega^{z,e}}(0, z) &= G_\delta^{\omega^{z,\emptyset}}(0, z) + \delta G_\delta^{\omega^{z,\emptyset}}(0, z) \sum_{e' \in \nu} (p^e(e') - p^\emptyset(e')) G_\delta^{\omega^{z,e}}(z + e', z) \\ &\quad + \delta G_\delta^{\omega^{z,\emptyset}}(0, z + e) \sum_{e' \in \nu} (p^{-e}(e') - p^\emptyset(e')) G_\delta^{\omega^{z,e}}(z + e + e', z), \end{aligned}$$

where we used a notation from (2.3).

Hence to compute the numerator of (7.1) using the expansion (7.3), we can look at quantities such as

$$\mathbf{E}[\mathbf{1}\{\mathcal{I}(\omega^{z,e})\} G_\delta^{\omega^{z,\emptyset}}(0, z) G_\delta^{\omega^{z,e}}(z + e', z)],$$

and

$$\mathbf{E}[\mathbf{1}\{\mathcal{I}(\omega^{z,e})\} G_\delta^{\omega^{z,\emptyset}}(0, z + e) G_\delta^{\omega^{z,e}}(z + e + e', z)],$$

for $e, e' \in \nu$.

From now on we fix $e \in \nu$. In order to handle the first type of terms (the proof is similar for the second type of terms) we introduce the measure

$$d\tilde{\mu}^z = \frac{\mathbf{1}\{\mathcal{I}\}\mathbf{1}\{\mathcal{C}(z) = e\} G_\delta^{\omega^{z,\emptyset}}(0, z)}{\mathbf{E}_{1-\varepsilon}[\mathbf{1}\{\mathcal{I}\}\mathbf{1}\{\mathcal{C}(z) = e\} G_\delta^{\omega^{z,\emptyset}}(0, z)]} d\mathbf{P}_{1-\varepsilon},$$

and for $e_+ \in \nu$ we introduce the Kalikow environment, corresponding to this measure on the environment and the point $z + e_+$, defined by

$$\begin{aligned} \tilde{p}_{z,e,z+e_+}(y, e') &= \frac{E_{\tilde{\mu}^z}[G_\delta^\omega(z + e_+, y) p^\omega(y, y + e')]}{E_{\tilde{\mu}^z}[G_\delta^\omega(z + e_+, y)]} \\ &= \frac{\mathbf{E}_{1-\varepsilon}[\mathbf{1}\{\mathcal{I}\} G_\delta^{\omega^{z,\emptyset}}(0, z) G_\delta^\omega(z + e_+, y) p^\omega(y, y + e') \mid \mathcal{C}(z) = e]}{\mathbf{E}_{1-\varepsilon}[\mathbf{1}\{\mathcal{I}\} G_\delta^{\omega^{z,\emptyset}}(0, z) G_\delta^\omega(z + e_+, y) \mid \mathcal{C}(z) = e]}. \end{aligned}$$

Once again Kalikow's property geometrically killed random walks does not use any properties on the measure on the environment, we have for any $z \in \mathbb{Z}^d$ and $e, e' \in \nu$

$$(7.4) \quad \frac{\mathbf{E}_{1-\varepsilon}[\mathbf{1}\{\mathcal{I}\}\mathbf{1}\{\mathcal{C}(z) = e\} G_\delta^{\omega^{z,\emptyset}}(0, z) G_\delta^\omega(z + e', z)]}{\mathbf{E}[\mathbf{1}\{\mathcal{I}\}\mathbf{1}\{\mathcal{C}(z) = e\} G_\delta^{\omega^{z,\emptyset}}(0, z)]} = G_\delta^{\tilde{p}_{z,e,z+e'}}(z + e', z).$$

Decomposing this according to the configurations at y and denoting $\mathbf{P}_{1-\varepsilon}^{z,e}[\cdot] = \mathbf{P}_{1-\varepsilon}[\cdot \mid \mathcal{C}(z) = e]$, we get

$$(7.5) \quad \begin{aligned} \tilde{p}_{z,e,z+e_+}(y, e') &= \sum_{A \in \{0,1\}^\nu} \mathbf{P}^{z,e}[\mathcal{C}(y) = A] \\ &\quad \times \frac{\mathbf{E}_{1-\varepsilon}^{z,e}[\mathbf{1}\{\mathcal{I}\} G_\delta^{\omega^{z,\emptyset}}(0, z) G_\delta^\omega(z + e_+, y) \mid \mathcal{C}(y) = A]}{\mathbf{E}_{1-\varepsilon}^{z,e}[\mathbf{1}\{\mathcal{I}\} G_\delta^{\omega^{z,\emptyset}}(0, z) G_\delta^\omega(z + e_+, y)]} p^A(y, e'), \end{aligned}$$

where the conditional expectation is set to be 0 when it is not well-defined.

In the next proposition we will use $a^+ = 0 \vee a$ and from now on we will omit the subscript in $\tilde{p}_{z,e,z+e_+}$.

Proposition 7.1. *For $\varepsilon < \varepsilon_7$ and $z, e, e_+ \in \mathbb{Z}^d \times \nu^2$ and $\delta \geq 1/2$, we have for $y \in \mathbb{Z}^d$, $e' \in \nu$*

$$|\tilde{p}(y, e') - p_0^{z,e}(y, e')| \leq (C_{14}e^{C_{15}((z-y)\cdot\vec{\ell})^+})\varepsilon,$$

where ε_7 , C_{14} and C_{15} depends on ℓ and d .

This proposition will be used to link the Green function of $\tilde{p}_{z,e,z+e_+}$ to the one of $p_0^{z,e}$. In view of (7.5) the previous proposition comes from

Proposition 7.2. *For $0 < \varepsilon < \varepsilon_8$, $y, z \in \mathbb{Z}^d$, $A \in \{0, 1\}^\nu \setminus \nu$,*

$$\frac{\mathbf{E}_{1-\varepsilon}[\mathbf{1}\{\mathcal{I}(\omega^{z,e})\}G_\delta^{\omega^{z,\emptyset}}(0, z)G_\delta^{\omega^{z,e}}(z + e_+, y) \mid \mathcal{C}(y) = A]}{\mathbf{E}_{1-\varepsilon}[\mathbf{1}\{\mathcal{I}(\omega^{z,e})\}G_\delta^{\omega^{z,\emptyset}}(0, z)G_\delta^{\omega^{z,e}}(z + e_+, y) \mid \mathcal{C}(y) = \emptyset]} \leq C_{16}e^{C_{17}((z-y)\cdot\vec{\ell})^+},$$

for ε_8 , C_{16} , C_{17} depending only on ℓ and d for $\delta \geq 1/2$.

In order to prove Proposition 7.1, once we have noticed that we have $\mathbf{P}[\mathcal{C}(y) = \emptyset] \geq \gamma_1$ and

$$\begin{aligned} & \mathbf{E}_{1-\varepsilon}^{z,e}[\mathbf{1}\{\mathcal{I}\}G_\delta^{\omega^{z,\emptyset}}(0, z)G_\delta^\omega(z + e_+, y)] \\ & \geq \mathbf{P}[\mathcal{C}(y) = \emptyset]\mathbf{E}_{1-\varepsilon}[\mathbf{1}\{\mathcal{I}(\omega^{z,e})\}G_\delta^{\omega^{z,\emptyset}}(0, z)G_\delta^{\omega^{z,e}}(z + e_+, y) \mid \mathcal{C}(y) = \emptyset], \end{aligned}$$

it suffices to use the Proposition 7.2 with arguments close to the ones appearing in the proof of Proposition 6.2 to show that the dominant term in (7.5) is the one corresponding to $\{\mathcal{C}(y) = \emptyset\}$.

Obviously Proposition 7.2 has strong similarities with Proposition 6.1, since the only difference is that the upper bound is weaker, which is simply due to technical reasons. Moreover, since the proof is rather technical and independent of the rest of the argument, we prefer to defer it to Section 8.

7.2. Expansion of Green functions. Once Proposition 7.1 is proved, we are able to approximate the Green functions through the same type of arguments as given in [22]. Heuristically, we may say that if environments are close then the Green functions should be close at least on short distance scales. Compared to [22], there is a twist due to the fact that we do not have uniform ellipticity and that our control on the environment in Proposition 7.1 is only uniform in the direction of the drift. Moreover our “limiting environment” as ε goes to 0 is not translation invariant (nor uniformly elliptic). Hence we need some extra work to adapt the methods of [22].

Proposition 7.3. *For any $z \in \mathbb{Z}^d$, $e, e' \in \nu$, $e'' \in \nu \cup \{0\}$ we get for $\delta \geq 1/2$*

$$\left| G_\delta^{\tilde{p}}(z + e' + e'', z) - G_\delta^{\omega_0^{z,e}}(z + e' + e'', z) \right| \leq o_\varepsilon(1),$$

where $o_\varepsilon(\cdot)$ depends only on ℓ and d .

Proof. The proof will be divided in two main steps:

- (1) prove that there exists transition probabilities \bar{p} that are uniformly close to those corresponding to the environment $\omega_0^{z,e}$ on the whole lattice and which has a Green function close to the one of the environment $\tilde{\omega}$,
- (2) prove the same statement as in Proposition 7.3 but for the environment \bar{p} . This is inspired from the proof of Lemma 3 in [22].

For the first step, we will show that the random walk is unlikely to visit often z and go far away in the direction opposite to the drift, i.e. we want to show that for any $\varepsilon_1 > 0$

$$G_\delta^{\tilde{p}}(z + e', z) - G_{\delta, \{x \in \mathbb{Z}^d, x \cdot \vec{\ell} < z \cdot \vec{\ell} - A\}}^{\tilde{p}}(z + e', z) < \varepsilon_1 \text{ for } A \text{ large and } \varepsilon \text{ small,}$$

where we used a notation of (4.8). This inequality comes from the fact that except at z and $z + e$ the local drift under \tilde{p} can be set to be uniformly positive in the direction ℓ in any half-space $\{x \in \mathbb{Z}^d, x \cdot \ell > -A\}$ for ε small.

In a first time, we show that the escape probability from z and $z + e'$ is lower bounded in the environment \tilde{p} . For this we can easily adapt a classical super-martingale argument, see Lemma 1.1 in [25], to get that for any $\eta > 0$ there exists $f(\eta) > 0$ such that for any random walk on \mathbb{Z}^d defined by a Markov operator $P(x, y)$ such that $(\sum_{y \sim x} P(x, y)(y - x)) \cdot \vec{\ell} > \eta$, for x such that $x \cdot \vec{\ell} \geq 0$, we have

$$(7.6) \quad P_0[X_n \cdot \vec{\ell} \geq 0, n > 0] > f(\eta).$$

Now by Proposition 7.1, it is possible to fix a percolation parameter $1 - \varepsilon$ where ε is chosen small enough so that

- The drift $d(\tilde{p})(x) = \sum_{e \in \nu} \tilde{p}(x, x + e)e$ is such that $d(\tilde{p})(x) \cdot \vec{\ell} > d_\emptyset \cdot \vec{\ell}/2$ for x such that $x \cdot \vec{\ell} \geq (z + 2de^{(1)}) \cdot \vec{\ell}$ (this way we avoid the transitions probabilities at the vertices z and $z + e$ which are special).
- The transition probabilities on the shortest paths from z and $z + e'$ to $z + 2de^{(1)}$ (with length inferior to some γ_1) are greater than $\kappa_0/2$.

Hence we can get a lower bound for the escape probability under \tilde{p} :

$$(7.7) \quad \begin{aligned} & \min_{y \in \{z, z + e'\}} P_y^{\tilde{p}}[T_{\{z, z + e'\}}^+ = \infty] \\ & \geq \min_{y \in \{z, z + e'\}} P_y^{\tilde{p}}[T_{\{z, z + e'\}}^+ > T_{z + 2de^{(1)}}] P_{z + 2de^{(1)}}^{\tilde{p}}[(X_n - (z + 2de^{(1)})) \cdot \vec{\ell} \geq 0, n > 0] \\ & \geq f(d_\emptyset \cdot \vec{\ell}/2) \left(\frac{\kappa_0}{2}\right)^{\gamma_1} = \gamma_2. \end{aligned}$$

Now we need to show that the walk is unlikely to go far to the left. Consider any random walk on \mathbb{Z}^d given by a transition operator $P(x, y)$ such that $d^P(x) := \sum_{y \sim x} P(x, y)(y - x) \cdot \vec{\ell} > (d_\emptyset \cdot \vec{\ell})/2 = \gamma_3$. We know that

$$M_n^P = X_n - X_0 - \sum_{i=1}^{n-1} d^P(X_i),$$

is a martingale with jumps bounded by 2. Hence since $d^P(x) \geq \gamma_3$, we can use Azuma's inequality, see [1], to get

$$\begin{aligned} P_0[T_{\{x \in \mathbb{Z}^d, x \cdot \vec{\ell} < -A\}} < \infty] &\leq \sum_{n \geq 0} P_0 \left[M_n^P \cdot \vec{\ell} < -A - \gamma_3 n \right] \\ &\leq \sum_{n \geq 0} \exp\left(-\frac{(A + \gamma_3 n)^2}{8n}\right) \leq \gamma_4 \exp\left(-\frac{\gamma_3 A}{4}\right). \end{aligned}$$

Set $\varepsilon' > 0$ small enough. Taking $A = A(\varepsilon')$ large enough, depending also on d and ℓ , we can make the right-hand side lower than ε_1 . Now let us choose ε small enough so that for any $y \in \{x \in \mathbb{Z}^d, x \cdot \vec{\ell} \geq z \cdot \vec{\ell} - A - 1 \text{ and } x \neq \{z, z + e'\}\}$ we have $d^{\tilde{w}}(y) \cdot \vec{\ell} > (d_\emptyset \cdot \vec{\ell})/2$. Then the previous imply

$$(7.8) \quad \begin{aligned} &\max_{y \in \{z, z + e'\}} P_y^{\tilde{P}}[T_{\{x \in \mathbb{Z}^d, x \cdot \vec{\ell} < z \cdot \vec{\ell} - A - 1\}} < T_{\{z, z + e'\}}^+] \\ &\leq \max_{y \sim z \text{ or } y \sim z + e'} P_y^{\tilde{P}}[T_{\{x \in \mathbb{Z}^d, x \cdot \vec{\ell} < z \cdot \vec{\ell} - A - 1\}} < T_{\{z, z + e'\}}^+] \leq \varepsilon', \end{aligned}$$

since the event in the middle depends only on the transitions probabilities at the vertices of $\{x \in \mathbb{Z}^d, x \cdot \ell \geq z \cdot \vec{\ell} - A - 1 \text{ and } x \neq \{z, z + e'\}\}$.

Moreover by (7.7) we have

$$(7.9) \quad G_\delta^{\tilde{P}}(z + e', z + e') = P_{z+e'}^{\tilde{P}}[T_{z+e'}^+ < \tau_\delta]^{-1} \leq \frac{1}{\gamma_2} \text{ and } G_\delta^{\tilde{P}}(z, z) \leq \frac{1}{\gamma_2},$$

which decomposing with respect to the number of excursions to z and $z + e'$ and using (7.8) yields

$$(7.10) \quad P_{z+e'}^{\tilde{P}}[T_{\{x \in \mathbb{Z}^d, x \cdot \vec{\ell} < z \cdot \vec{\ell} - A - 1\}} < \infty] < \frac{2\varepsilon'}{\gamma_2}.$$

For ε small enough to verify the previous conditions we have using (7.9) and (7.10)

$$(7.11) \quad \begin{aligned} &G_\delta^{\tilde{P}}(z + e', z) - G_{\delta, \{x \in \mathbb{Z}^d, x \cdot \vec{\ell} < z \cdot \vec{\ell} - A - 1\}}^{\tilde{P}}(z + e', z) \\ &\leq P_{z+e'}^{\tilde{P}}[T_{\{x \in \mathbb{Z}^d, x \cdot \vec{\ell} < z \cdot \vec{\ell} - A - 1\}} < \infty] \max_{y \in \{x \in \mathbb{Z}^d, x \cdot \vec{\ell} < z \cdot \vec{\ell} - A - 1\}} G_\delta^{\tilde{P}}(y, z) \\ &\leq \frac{2\varepsilon'}{\gamma_2} G_\delta^{\tilde{P}}(z, z) = \frac{2\varepsilon'}{\gamma_2}. \end{aligned}$$

So that introducing $\bar{\omega}(y, e')$ so that

$$\begin{aligned}\bar{p}(y, e') &= \tilde{p}(y, e') \text{ for } y \text{ such that } (y - z) \cdot \vec{\ell} \geq -A(\varepsilon') \\ \bar{p}(y, e') &= p^{\omega_0^{z, e'}}(y, e') \text{ for } y \text{ such that } (y - z) \cdot \vec{\ell} < -A(\varepsilon')\end{aligned}$$

A consequence of (7.11) is that

$$(7.12) \quad \left| G_\delta^{\bar{p}}(z + e', z) - G_\delta^{\tilde{p}}(z + e', z) \right| \leq \gamma_5 \varepsilon',$$

where, by Proposition 7.1, $\bar{\omega}$ (depending on ε') is such that

$$(7.13) \quad \max_{e' \in \nu, y \in \mathbb{Z}^d} \left| \bar{p}(y, e') - p^{\omega_0^{z, e'}}(y, e') \right| \leq C_{14} e^{C_{15} A(\varepsilon')} \varepsilon \leq \varepsilon',$$

for ε small enough. This completes step (1).

We can start step (2) of the proof. Since our control on the environment is uniform and our remaining task is to use methods similar to those of [22] to prove that there exists a $o(\cdot)$ depending only on d and ℓ such that

$$(7.14) \quad \left| G_\delta^{\omega_0^{z, e'}}(z + e' + e'', z) - G_\delta^{\bar{p}}(z + e' + e'', z) \right| = o(1),$$

which in view of (7.12) is enough to prove Proposition 7.3.

Let us define M the operator of multiplication by $(\pi^{\omega_0^{z, e'}})^{1/2}$ given for $f : \mathbb{Z}^d \rightarrow \mathbb{R}$, by

$$M(f)(y) = (\pi^{\omega_0^{z, e'}}(y))^{1/2} f(y).$$

We consider a transition operator $P^{s, \delta}$ of a random walk on $\mathbb{Z}^d \cup \{\Delta\}$ given by

$$\begin{aligned}P^{s, \delta}(x, x + e^{(i)}) &= P^{s, \delta}(x + e^{(i)}, x) \\ &= \delta (\pi^{\omega_0^{z, e'}}(x))^{1/2} p^{\omega_0^{z, e'}}(x, x + e^{(i)}) (\pi^{\omega_0^{z, e'}}(x + e^{(i)}))^{-1/2} \\ &= \delta (\pi^{\omega_0^{z, e'}}(x + e^{(i)}))^{1/2} p^{\omega_0^{z, e'}}(x + e^{(i)}, x) (\pi^{\omega_0^{z, e'}}(x))^{-1/2},\end{aligned}$$

for any $i = 1, \dots, 2d$ and for $x \notin \{z, z + e, \Delta\}$

$$P^{s, \delta}(x, \Delta) = (1 - \delta) + \delta \sum_{e^{(i)} \in \nu} (p^\emptyset(e^{(i)}) p^\emptyset(-e^{(i)}))^{1/2},$$

$$P^{s, \delta}(z, \Delta) = (1 - \delta) + \delta \sum_{e^{(i)} \in \nu \setminus \{e\}} (p^e(e^{(i)}) p^e(-e^{(i)}))^{1/2},$$

$$P^{s, \delta}(z + e, \Delta) = (1 - \delta) + \delta \sum_{e^{(i)} \in \nu \setminus \{-e\}} (p^{-e}(e^{(i)}) p^{-e}(-e^{(i)}))^{1/2},$$

and $P^{s, \delta}(\Delta, \Delta) = 1$.

We have for $x, y \neq \Delta$,

$$G_\delta^{\omega_0^{z, e'}}(x, y) = ((I - \delta P^{\omega_0^{z, e'}})^{-1})(x, y) = (M^{-1}(I - P^{s, \delta})^{-1}M)(x, y)$$

$$= (M^{-1}G^{s,\delta}M)(x, y),$$

where $G^{s,\delta}$ is the Green function of $P^{s,\delta}$. In a similar way, we have for $x, y \neq \Delta$

$$G_{\delta}^{\bar{p}}(x, y) = (M^{-1}G^{\bar{s},\delta}M)(x, y),$$

where because of (7.13) the associated operator $P^{\bar{s},\delta} = M^{-1}P^{\bar{p}}M$ verifies

$$\begin{aligned} P^{\bar{s},\delta}(x, x+e) &= P^{s,\delta}(x, x+e) + \varepsilon\xi_{\varepsilon}(x, e) \\ \text{and } P^{\bar{s},\delta}(x, \Delta) &= P^{s,\delta}(x, \Delta) + \varepsilon\xi_{\varepsilon}(x, \Delta), \end{aligned}$$

where $\xi_{\varepsilon}(\cdot, \cdot)$ are uniformly bounded.

Now, we expand the Green function, using (7.2) to obtain that for any n

$$G_{\delta}^{\bar{p}}(x, x') - G_{\delta}^{\omega_0^{z,e}}(x, x') = \sum_{i=1}^n (\delta\varepsilon)^i S_i(x, x') + (\delta\varepsilon)^{n+1} R_n(x, x'),$$

where

$$\begin{aligned} S_n(x, x') &= \sum_{x_1, \dots, x_n} \sum_{e_1, \dots, e_n} G_{\delta}^{\omega_0^{z,e}}(x, x_1) \xi_{\varepsilon}(x_1, e_1) G_{\delta}^{\omega_0^{z,e}}(x_1 + e_1, x_2) \cdots \\ &\quad \times \xi_{\varepsilon}(x_n, e_n) G_{\delta}^{\omega_0^{z,e}}(x_n + e_n, x'), \end{aligned}$$

and

$$R_n(x, x') = \sum_{x^* \in \mathbb{Z}^d} S_n(x, x^*) \sum_{e^* \in \nu} \xi_{\varepsilon}(x^*, e^*) G_{\delta}^{\bar{p}}(x^* + e^*, x').$$

Consider the transformation

$$\begin{aligned} S_n(x, x') &= \left(\frac{\pi^{\omega_0^{z,e}}(x')}{\pi^{\omega_0^{z,e}}(x)} \right)^{1/2} \sum_{\substack{x_1, \dots, x_n \\ e_1, \dots, e_n}} G^{s,\delta}(x, x_1) \xi_{\varepsilon}(x_1, e_1) \left(\frac{\pi^{\omega_0^{z,e}}(x_1)}{\pi^{\omega_0^{z,e}}(x_1 + e_1)} \right)^{1/2} \\ &\quad \times G^{s,\delta}(x_1 + e_1, x_2) \cdots \left(\frac{\pi^{\omega_0^{z,e}}(x_n)}{\pi^{\omega_0^{z,e}}(x_n + e_n)} \right)^{1/2} G^{s,\delta}(x_n + e_n, x'), \end{aligned}$$

and

$$\begin{aligned} R_n(x, x') &= \left(\frac{\pi^{\omega_0^{z,e}}(x')}{\pi^{\omega_0^{z,e}}(x)} \right)^{1/2} \sum_{\substack{x_1, \dots, x_n \\ e_1, \dots, e_n}} G^{s,\delta}(x, x_1) \xi_{\varepsilon}(x_1, e_1) \left(\frac{\pi^{\omega_0^{z,e}}(x_1)}{\pi^{\omega_0^{z,e}}(x_1 + e_1)} \right)^{1/2} \\ &\quad \times G^{s,\delta}(x_1 + e_1, x_2) \cdots \left(\frac{\pi^{\omega_0^{z,e}}(x_n)}{\pi^{\omega_0^{z,e}}(x_n + e_n)} \right)^{1/2} G^{\bar{s},\delta}(x_n + e_n, x'). \end{aligned}$$

We have for any $x \in \mathbb{Z}^d$ and $\delta \geq 1/2$,

$$|1 - P^{s,\delta}(x, \Delta)| \geq \frac{\delta}{2} \min_{e_k \in \nu} \sum_{j=1}^d \left(\sqrt{p^{e_k}(e^{(j)})} - \sqrt{p^{e_k}(-e^{(j)})} \right)^2 = \gamma_6.$$

Moreover for any $x \in \mathbb{Z}^d$ and $e_i \in \nu$ we get by (2.5) that

$$\frac{\pi^{\omega_0^{z,e}}(x)}{\pi^{\omega_0^{z,e}}(x + e_i)} \leq \kappa_1^2 e^{2\lambda},$$

and for $x, x' \in \mathbb{Z}^d$ we obtain

$$\begin{aligned} & \sum_{\substack{x_1, \dots, x_n \\ e_1, \dots, e_n}} G^{s,\delta}(x, x_1) G^{s,\delta}(x_1 + e_1, x_2) \cdots G^{s,\delta}(x_n + e_n, x') \\ & \leq \left(\sum_{x_1} G^{s,\delta}(x, x_1) (2d) \right) \max_{x_* \in \mathbb{Z}^d} \sum_{\substack{x_2, \dots, x_n \\ e_2, \dots, e_n}} G^{s,\delta}(x_*, x_2) \cdots G^{s,\delta}(x_n + e_n, x') \\ & \leq \frac{2d}{1 - \max_x P^{s,\delta}(x, \Delta)} \max_{x_* \in \mathbb{Z}^d} \sum_{\substack{x_2, \dots, x_n \\ e_2, \dots, e_n}} G^{s,\delta}(x_*, x_2) \cdots G^{s,\delta}(x_n + e_n, x') \\ & \leq \cdots \leq \left(\frac{2d}{1 - \gamma_6} \right)^n, \end{aligned}$$

where we used an easy recursion to obtain the last inequality. Finally we get

$$\begin{aligned} S_n(x, x') &= \left(\frac{\pi^{\omega_0^{z,e}}(x')}{\pi^{\omega_0^{z,e}}(x)} \right)^{1/2} \left(\kappa_1^2 e^{2\lambda} \left(\sup_{y,e} |\xi_\varepsilon(y, e)| \right) \frac{2d}{1 - \gamma_6} \right)^{n+1} \\ &\leq \left(\frac{\pi^{\omega_0^{z,e}}(x')}{\pi^{\omega_0^{z,e}}(x)} \right)^{1/2} \gamma_7^{n+1}, \end{aligned}$$

for some positive constant γ_7 , depending only on d and ℓ . We can get a similar estimate for the remaining term $R_n(x, x')$ considering that $1 - P^{s,\delta}(x, \Delta) \sim 1 - P^{\bar{s},\delta}(x, \Delta)$. This implies that for $\varepsilon < \gamma_7^{-1}/2$ small enough, the series $\sum_{k=0}^{\infty} (\varepsilon\delta)^k S_k(x, x')$ is convergent and upper bounded by a constant independent of δ and that

$$\begin{aligned} G_{\delta}^{\bar{P}}(x, x') - G_{\delta}^{\omega_0^{z,e}}(x, x') &= \sum_{k=1}^{\infty} (\delta\varepsilon)^k S_k(x, x') \\ &= \left(\frac{\pi^{\omega_0^{z,e}}(x')}{\pi^{\omega_0^{z,e}}(x)} \right)^{1/2} O(\varepsilon), \end{aligned}$$

where $O(\cdot)$ depends only on d and ℓ .

Applying this last result for all cases $x = z + e' + e''$ and $x' = z$ yields (7.14) and thus the result. \square

7.3. First order expansion of the asymptotic speed. We have now all the necessary tools to compute the asymptotic speed. Applying Proposition 7.3 (which relies on Proposition 7.1), we get

$$G_{\delta}^{\bar{P}_{z,e,z+e'}}(z + e', z) = G_{\delta}^{\omega_0^{z,e}}(z + e', z) + o(1),$$

where the $o(\cdot)$ depends only on d and ℓ . Hence putting the previous equation together with (7.4), we obtain

$$(7.15) \quad \begin{aligned} & \mathbf{E}_{1-\varepsilon}[\mathbf{1}\{\mathcal{I}\}\mathbf{1}\{\mathcal{C}(z) = e\}G_\delta^{\omega^{z,\emptyset}}(0, z)G_\delta^\omega(z + e', z)] \\ &= (1 + o(1))\mathbf{E}[\mathbf{1}\{\mathcal{I}\}\mathbf{1}\{\mathcal{C}(z) = e\}G_\delta^{\omega^{z,\emptyset}}(0, z)]G_\delta^{\omega_0^{0,e}}(e', 0), \end{aligned}$$

where the $o(\cdot)$ depends only on d and ℓ .

Applying the same methods for $\tilde{p}_{z+e, -e, z+e+e'}$ yields

$$(7.16) \quad \begin{aligned} & \mathbf{E}[\mathbf{1}\{\mathcal{I}(\omega^{z,e})\}G_\delta^{\omega^{z,\emptyset}}(0, z+e)G_\delta^{\omega^{z,e}}(z+e+e', z)] \\ &= (1 + o(1))\mathbf{E}[\mathbf{1}\{\mathcal{I}(\omega^{z,e})\}G_\delta^{\omega^{z,\emptyset}}(0, z+e)]G_\delta^{\omega_0^{0,e}}(e+e', 0), \end{aligned}$$

where the $o(\cdot)$ depends only on d and ℓ .

Let us denote

$$\phi(e) = \sum_{e' \in \nu} (p^e(e') - p^\emptyset(e'))G_\delta^{\omega_0^{0,e}}(e', 0),$$

and

$$\psi(e) = \sum_{e' \in \nu} (p^{-e}(e') - p^\emptyset(e'))G_\delta^{\omega_0^{0,e}}(e+e', 0).$$

Hence imputing the estimates (7.15) and (7.16) into the expression of (7.1) modified using (7.3), we get

$$(7.17) \quad \begin{aligned} & d_\delta^\omega(z) - d_\emptyset \\ &= \frac{\varepsilon(1 + o(1))}{\mathbf{E}_{1-\varepsilon}[\mathbf{1}\{\mathcal{I}\}G_\delta^\omega(0, z)]} \left[\mathbf{E}_{1-\varepsilon}[\mathbf{1}\{\mathcal{I}(\omega^{z,e})\}G_\delta^{\omega^{z,\emptyset}}(0, z)] \left(\sum_{e \in \nu} (1 + \delta\phi(e))(d_e - d_\emptyset) \right) \right. \\ & \quad \left. + \mathbf{E}_{1-\varepsilon}[\mathbf{1}\{\mathcal{I}(\omega^{z,e})\}G_\delta^{\omega^{z,\emptyset}}(0, z+e)] \left(\sum_{e \in \nu} \delta\psi(e)(d_e - d_\emptyset) \right) \right] + O(\varepsilon^2), \end{aligned}$$

where the $o(\cdot)$ and $O(\cdot)$ depend only on d and ℓ .

We are not able to derive uniform estimates for $d_\delta^\omega(z)$, nevertheless we are still able to estimate the asymptotic speed.

Lemma 7.1. *We have for $\delta \geq 1/2$, $z \in \mathbb{Z}^d$ and $e \in \nu$,*

$$\left| \frac{\mathbf{E}[\mathbf{1}\{\mathcal{I}(\omega^{z,e})\}G_\delta^{\omega^{z,\emptyset}}(0, z)]}{\mathbf{E}[\mathbf{1}\{\mathcal{I}\}G_\delta^\omega(0, z)]} - 1 \right| \leq O(\varepsilon),$$

where the $O(\cdot)$ depends only on d and ℓ .

Proof. Recalling that $\mathbf{P}[\mathcal{C}(z) = \emptyset] = 1 + O(\varepsilon)$, we get

$$\frac{\mathbf{E}[\mathbf{1}\{\mathcal{I}(\omega^{z,e})\}G_\delta^{\omega^{z,\emptyset}}(0, z)]}{\mathbf{E}[\mathbf{1}\{\mathcal{I}\}G_\delta^\omega(0, z)]} \leq \frac{1}{\mathbf{P}[\mathcal{C}(z) = \emptyset]} \frac{\mathbf{E}[\mathbf{1}\{\mathcal{I}(\omega^{z,e})\}G_\delta^{\omega^{z,\emptyset}}(0, z)]}{\mathbf{E}[\mathbf{1}\{\mathcal{I}(\omega^{z,\emptyset})\}G_\delta^{\omega^{z,\emptyset}}(0, z)]} \leq 1 + O(\varepsilon).$$

In order to prove the other bound we will use methods very similar to those used before and we will not give a fully-detailed proof. In words the idea is that we can condition the environment to be open on any finite ball without changing, up to terms of order ε , the value of the expectation of Green functions. Hence, up to a $O(\varepsilon)$, we may suppose that $B^E(z, 2)$ contains only open edges and with this conditioning the two terms appearing in the quotient of the lemma are the same. With more formalism, we have

$$(7.18) \quad \mathbf{E}[\mathbf{1}\{\mathcal{I}(\omega^{z,e})\}G_\delta^{\omega^{z,\emptyset}}(0, z)] = \sum_{\substack{A \in \{0,1\}^{B^E(z,2)} \\ A \neq \emptyset}} \mathbf{P}[\{e \in B^E(z, 2), e \in \omega\} = A] \\ \times \mathbf{E}[\mathbf{1}\{\mathcal{I}(\omega^{z,e})\}G_\delta^{\omega^{z,\emptyset}}(0, z) \mid \{e \in B^E(z, 2), e \in \omega\} = A],$$

it can be shown that for any $A \subset B^E(z, 2)$, $A \neq \emptyset$

$$(7.19) \quad \frac{\mathbf{E}[\mathbf{1}\{\mathcal{I}(\omega^{z,e})\}G_\delta^{\omega^{z,\emptyset}}(0, z) \mid \{e \in B^E(z, 2), e \in \omega\} = A]}{\mathbf{E}[\mathbf{1}\{\mathcal{I}(\omega^{z,e})\}G_\delta^{\omega^{z,\emptyset}}(0, z)]} < \gamma_1,$$

where γ_1 depends only on d and ℓ . The method is the same as before

- (1) We apply Lemma 4.1 to decompose the Green function into a hitting probability and a resistance.
- (2) With Lemma 4.2 we decompose the resistance appearing in (1) into the same resistance in $\omega^{B^E(z,2),1}$ and a local perturbation.
- (3) By upper bounding the integrand by terms which do not depend on the state of the edges of $B^E(z, 2)$ and using the same trick as in (6.7) we prove that for ε small enough

$$\frac{\mathbf{E}\left[\mathbf{1}\{\mathcal{I}(\omega_{(z,2),A}^{z,e})\}P_0^{\omega_{(z,2),A}^{z,\emptyset}}[T_z < \tau_\delta]R^{\omega_{(z,2),1}}[z \leftrightarrow \Delta]\right]e^{2\lambda z \cdot \vec{\ell}}}{\mathbf{E}[\mathbf{1}\{\mathcal{I}(\omega^{z,e})\}G_\delta^{\omega^{z,\emptyset}}(0, z)]} < \gamma_2.$$

We can use arguments similar to the ones in the proof of Lemma 6.1 (essentially repeating the steps (6.6), (6.7), (6.8) and (6.9)) to prove that

$$\frac{\mathbf{E}\left[\mathbf{1}\{\mathcal{I}(\omega_{(z,2),A}^{z,e})\}P_0^{\omega_{(z,2),A}^{z,\emptyset}}[T_z < \tau_\delta]L_{z,2}^{C_2}e^{2\lambda L_{z,2}}\right]}{\mathbf{E}[\mathbf{1}\{\mathcal{I}(\omega^{z,e})\}G_\delta^{\omega^{z,\emptyset}}(0, z)]} \\ = \frac{\mathbf{E}\left[\mathbf{1}\{\mathcal{I}(\omega_{(z,2),A}^{z,e})\}P_0^{\omega_{(z,2),A}^{z,\emptyset}}[T_z < \tau_\delta]L_{z,2}^{C_2}e^{2\lambda L_{z,2}} \mid \mathcal{C}(z) = e\right]}{\mathbf{E}[\mathbf{1}\{\mathcal{I}\}G_\delta^{\omega^{z,\emptyset}}(0, z) \mid \mathcal{C}(z) = e]} < \gamma_3,$$

since $L_{z,2}$ has arbitrarily large exponential moments under the measure $\mathbf{P}[\cdot \mid \mathcal{C}(z) = e]$, for ε small enough by Proposition 5.3. For the first equality in the previous equation, we implicitly used that $L_{z,2}$

does not depend on the configuration at z which is true by the first property of Proposition 4.1.

This reasoning yields (7.19) with $\gamma_1 = \gamma_2 + C_1\gamma_3$. Now, the equations (7.19) and (7.18) imply that

$$\begin{aligned} \mathbf{E}[\mathbf{1}\{\mathcal{I}(\omega^{z,e})\}G_\delta^{\omega^{z,0}}(0, z)] &= O(\varepsilon)\mathbf{E}[\mathbf{1}\{\mathcal{I}(\omega^{z,e})\}G_\delta^{\omega^{z,0}}(0, z)] \\ &\quad + \mathbf{E}[\mathbf{1}\{\mathcal{I}(\omega^{z,e})\}G_\delta^{\omega^{z,0}}(0, z), \{\mathbf{1}\{e \in \omega\}, e \in B^E(z, 2)\} = B^E(z, 2)], \end{aligned}$$

and since on $\{\mathbf{1}\{e \in \omega\}, e \in B^E(z, 2)\} = B^E(z, 2)$ we have $\mathbf{1}\{\mathcal{I}\}G_\delta^\omega(0, z) = \mathbf{1}\{\mathcal{I}(\omega^{z,e})\}G_\delta^{\omega^{z,0}}(0, z)$, it follows that

$$\begin{aligned} &\mathbf{E}[\mathbf{1}\{\mathcal{I}(\omega^{z,e})\}G_\delta^{\omega^{z,0}}(0, z)] \\ &= (1 + O(\varepsilon))\mathbf{E}[\mathbf{1}\{\mathcal{I}\}G_\delta^\omega(0, z), \{\mathbf{1}\{e \in \omega\}, e \in B^E(z, 2)\} = B^E(z, 2)] \\ &\leq (1 + O(\varepsilon))\mathbf{E}[\mathbf{1}\{\mathcal{I}\}G_\delta^\omega(0, z)], \end{aligned}$$

which yields the other bound. \square

Recalling Proposition 3.1, we can use (7.17) and Lemma 7.1 to get

$$\begin{aligned} &\frac{\sum_{z \in \mathbb{Z}^d} G_\delta^{\widehat{\omega}_\delta^\varepsilon}(0, z) \widehat{d}_\delta^\varepsilon(z)}{\sum_{z \in \mathbb{Z}^d} G_\delta^{\widehat{\omega}_\delta^\varepsilon}(0, z)} - d_\emptyset \\ &= \varepsilon(1 + o(1)) \frac{\sum_{z \in \mathbb{Z}^d} \sum_{e \in \nu} \mathbf{E}[\mathbf{1}\{\mathcal{I}\}G_\delta^\omega(0, z)](1 + \delta\phi(e))(d_e - d_\emptyset)}{\sum_{z \in \mathbb{Z}^d} \mathbf{E}[\mathbf{1}\{\mathcal{I}\}G_\delta^\omega(0, z)]} \\ &\quad + \varepsilon(1 + o(1)) \frac{\sum_{z \in \mathbb{Z}^d} \sum_{e \in \nu} \mathbf{E}[\mathbf{1}\{\mathcal{I}\}G_\delta^\omega(0, z + e)]\delta\psi(e)(d_e - d_\emptyset)}{\sum_{z \in \mathbb{Z}^d} \mathbf{E}[\mathbf{1}\{\mathcal{I}\}G_\delta^\omega(0, z)]} \\ &= \varepsilon \sum_{e \in \nu} (1 + \delta(\phi(e) + \psi(e)))(d_e - d_\emptyset) + o(\varepsilon), \end{aligned}$$

since $\sum_z \mathbf{E}[\mathbf{1}\{\mathcal{I}\}G_\delta^\omega(0, z)] = \sum_z \mathbf{E}[\mathbf{1}\{\mathcal{I}\}G_\delta^\omega(0, z + e)] = \mathbf{P}[\mathcal{I}]/(1 - \delta)$.

In order to simplify the previous expression we prove

Lemma 7.2. *We have*

$$\begin{aligned} &\sum_{e' \in \nu} (p^e(e') - p^\emptyset(e'))G^{\omega_0^{0,e}}(e', 0) + \sum_{e' \in \nu} (p^{-e}(e') - p^\emptyset(e'))G^{\omega_0^{0,e}}(e + e', 0) \\ &= (p^\emptyset(e) - p^\emptyset(-e))(G^{\omega_0^{0,e}}(0, 0) - G^{\omega_0^{0,e}}(e, 0)) - p^\emptyset(e). \end{aligned}$$

Proof. Recalling the notations (2.3), we get

$$p^e(e') - p^\emptyset(e') = \begin{cases} \frac{c(e')c(e)}{\pi^\emptyset \pi^e} & \text{if } e \neq e', \\ -\frac{c(e')}{\pi^\emptyset} & \text{if } e = e'. \end{cases}$$

Hence we get that,

$$\sum_{e' \neq e} \frac{c(e')c(e)}{\pi^\emptyset \pi^e} G^{\omega_0^{0,e}}(e', 0) = \frac{c(e)}{\pi^\emptyset} (G^{\omega_0^{0,e}}(0, 0) - 1),$$

and

$$\sum_{e' \neq e} \frac{c(e')c(-e)}{\pi^\emptyset \pi^{-e}} G^{\omega_0^{0,e}}(e + e', 0) = \frac{c(-e)}{\pi^\emptyset} G^{\omega_0^{0,e}}(e, 0).$$

Finally using $\frac{c(e)}{\pi^\emptyset} = p^\emptyset(e)$ and the previous equations, the computations are straightforward. \square

Recalling that $p^\emptyset(e) - p^\emptyset(-e) = d_\emptyset \cdot e$ and $1 - p^\emptyset(e) = \pi^e/\pi^\emptyset$, we see that the previous lemma means that

$$\alpha(e) = \phi(e) + \psi(e) = \frac{\pi^e}{\pi^\emptyset} + (d_\emptyset \cdot e)(G^{\omega_0^{0,e}}(0, 0) - G^{\omega_0^{0,e}}(e, 0)),$$

and so Proposition 3.2 yields by letting δ go to 1

$$(7.20) \quad v_\ell(1 - \varepsilon) = d_\emptyset + \varepsilon \sum_{e \in \nu} \alpha(e)(d_e - d_\emptyset) + o(\varepsilon).$$

We still may simplify slightly the expression of the speed we obtained using the following

$$\sum_{e \in \nu} \pi^e d_e = \sum_{i=1}^{2d} \sum_{e \neq e^{(i)}} c(e)e = (2d - 1) \sum_{e \in \nu} c(e)e = (2d - 1)\pi^\emptyset d_\emptyset = \sum_{e \in \nu} \pi^e d_\emptyset,$$

Inserting this last equation into (7.20) yields

$$v_\ell(1 - \varepsilon) = d_\emptyset + \varepsilon \sum_{e \in \nu} (d_\emptyset \cdot e)(G^{\omega_0^{0,e}}(0, 0) - G^{\omega_0^{0,e}}(e, 0))(d_e - d_\emptyset) + o(\varepsilon),$$

which proves Theorem 2.2. \square

8. ESTIMATE ON KALIKOW'S ENVIRONMENT

The section is devoted to the proof of Proposition 7.2 so that we still assume to have a fixed $z \in \mathbb{Z}^d$ and $e, e_+ \in \nu$. Before entering into the details let us present the main steps of the proof of the previous proposition which are rather similar to the ones in the proof of Proposition 6.1.

- (1) The Green functions behave essentially as a hitting probability multiplied by a resistance (normalized by the invariant measure). See (8.19).
- (2) Then we use the estimates on resistances of Proposition 4.2. This procedure will essentially give an upper bound of the numerator in Proposition 7.2 as a finite sum of terms which are linked to the denominator but with a local correlation around y due to the presence of

random variables similar to the random variable “ L_z ” which appeared in the proof of Proposition 6.1. See (8.27) and (8.28).

- (3) We finish the proof by decorrelation lemmas similar to Lemma 6.1 to handle the second type of terms we just described. See sub-section 8.3

Compared to Proposition 6.1 there is an extra difficulty added by the fact that we need to handle two Green functions instead of only one (in some sense we will even have three), hence we will apply Proposition 4.2 recursively, this is done in Proposition 8.2.

We point out that in addition, we cannot prove a decorrelation lemma involving one of the hitting probabilities coming from the Green functions appearing in Proposition 7.2. Hence we need to transform one of them into an expression which we will be able to decorrelate from a local modification of the environment and this will change slightly the outline of the proof given above. The aim of the next sub-section is to take care of this problem.

8.1. The perturbed hitting probabilities. We want to understand the effect of the change of configuration around y on the hitting probabilities

$P_{z+e_+}^{\omega_{y,A}^{z,e}}[T_y < \tau_\delta]$ and $P_0^{\omega_{y,A}^{z,\emptyset}}[T_z \leq \tau_\delta]$. The former term can be estimated since if we denote $B^*(y, k) = \left\{ t \in B(y, k), t \stackrel{B^E(y,k) \setminus \{z, z+e\}}{\leftrightarrow} y \right\}$ and

$$(8.1) \quad p_z^\omega(y, k) = \begin{cases} \max_{u \in \partial B^*(y, k)} P_{z+e_+}^\omega [T_u = T_{\partial B^*(y, k)} < \tau_\delta] & \text{if } z + e_+ \notin B^*(y, k), \\ 1 & \text{otherwise.} \end{cases}$$

then for any $k \geq 1$ such that $0 \notin B^*(y, k)$, we have

$$(8.2) \quad P_{z+e_+}^{\omega_{y,A}^{z,e}} [T_y < \tau_\delta] \leq \rho_d k^d p_z^{\omega_{y,A}^{z,e}}(y, k),$$

the special notation $B^*(y, k)$ is useful because in the configuration $\omega^{z,e}$ the walker can only reach y by entering the ball $B(y, k)$ through $B^*(y, k)$.

As we announced previously, the second hitting probability is more difficult to treat. Let us introduce the following notations

$$(8.3) \quad p_1^\omega(y, k) = \begin{cases} \max_{u \in \partial B(y, k)} P_0^\omega [T_u = T_{\partial B(y, k)} < \tau_\delta] & \text{if } 0 \notin B(y, k), \\ 1 & \text{otherwise,} \end{cases}$$

$$(8.4) \quad p_2^\omega(y, k) = \begin{cases} \max_{u \in \partial B(y, k)} P_u^\omega [T_z < \tau_\delta \wedge T_{\partial B(y, k)}^+] & \text{if } z \notin B(y, k), \\ 1 & \text{otherwise.} \end{cases}$$

To make notations lighter we also set

$$(8.5) \quad R_*^\omega(z) = e^{2\lambda z \cdot \vec{\ell}} R^\omega[z \leftrightarrow \Delta] \text{ and } R_*^\omega(y) = e^{2\lambda y \cdot \vec{\ell}} R^\omega[y \leftrightarrow \Delta],$$

and moreover we introduce

$$(8.6) \quad \bar{R}_*^\omega(y, k) = \begin{cases} \max_{u \in \partial B(y, k)} R_*^\omega[u \leftrightarrow z \cup \Delta] & \text{if } z \notin B(y, k), \\ 1 & \text{otherwise,} \end{cases}$$

where

$$(8.7) \quad \text{for any } u \in \mathbb{Z}^d, \quad R_*^\omega[u \leftrightarrow z \cup \Delta] = e^{2\lambda z \cdot \vec{\ell}} R^\omega[u \leftrightarrow z \cup \Delta].$$

then we have the following proposition.

Proposition 8.1. *Take any configuration ω and set $y, z \in \mathbb{Z}^d$ and $B = B(y, r)$ with $r \geq 1$ and $\delta \geq 1/2$. If $0, z \notin B$ and $P_0^\omega[T_z < \tau_\delta] > 2P_0^\omega[T_z < T_{\partial B} \wedge \tau_\delta]$, then we have*

$$P_0^\omega[T_z < \tau_\delta] \leq C_{19} r^{2d} p_1^\omega(y, k) p_2^\omega(y, k) \bar{R}_*^\omega(y, k).$$

If $0 \in B$, $z \notin B$ and $P_0^\omega[T_z < \tau_\delta] > 2P_0^\omega[T_z < T_{\partial B} \wedge \tau_\delta]$, then

$$P_0^\omega[T_z < \tau_\delta] \leq C_{19} r^{2d} p_2^\omega(y, k) \bar{R}_*^\omega(y, k).$$

Finally if $0 \notin B$ and $z \in B$,

$$P_0^\omega[T_z < \tau_\delta] \leq C_{19} r^{2d} p_1^\omega(y, k).$$

Thanks to this lemma we can say that $P_0^\omega[T_z < \tau_\delta]$ is either not influenced much by a local modification around y (in the case where naturally the walk will not visit y when it goes from 0 to z), or upper bounded by a product of at most three random variables. Two of them behave as hitting probabilities which are well suited for our future decorrelation purposes, the third random variable is essentially a resistance for which we have estimates as well.

Proof. We will only consider the case $0, z \notin B$, the other being similar but simpler. Our hypothesis implies

$$P_0^\omega[T_z < \tau_\delta] \leq 2P_0^\omega[T_{\partial B} \leq T_z < \tau_\delta],$$

we can get an upper bound on the right-hand term by Markov's property

$$(8.8) \quad P_0^\omega[T_B \leq T_z < \tau_\delta] = \sum_{u \in \partial B} P_0^\omega[T_u = T_{\partial B} < \tau_\delta] P_u^\omega[T_z < \tau_\delta] \\ \leq |\partial B| \max_{u \in \partial B} P_0^\omega[T_u = T_{\partial B} < \tau_\delta] \max_{u \in \partial B} P_u^\omega[T_z < \tau_\delta].$$

Denoting $z_1 \rightarrow \dots \rightarrow z_n$ the event that the n first vertices of $\partial B \cup z \cup \Delta$ visited are, in order, z_1, z_2, \dots, z_n , we can write for $u \in \partial B$

$$(8.9) \quad P_u^\omega[T_z < \tau_\delta] = E_u^\omega \left[\sum_n \sum_{z_1, \dots, z_n \in \partial B} \mathbf{1}\{z_1 \rightarrow \dots \rightarrow z_n \rightarrow z\} \right]$$

$$\begin{aligned}
&= \sum_n \sum_{z_1, \dots, z_n \in \partial B} E_u^\omega[\mathbf{1}\{z_1 \rightarrow \dots \rightarrow z_n\}] P_{z_n}^\omega[T_z < T_{\partial B}^+ \wedge \tau_\delta] \\
&\leq \max_{v \in \partial B} P_v^\omega[T_z < \tau_\delta \wedge T_{\partial B}^+] E_u^\omega \left[\sum_n \sum_{z_1, \dots, z_n \in \partial B} \mathbf{1}\{z_1 \rightarrow \dots \rightarrow z_n\} \right] \\
&= \max_{v \in \partial B} P_v^\omega[T_z < \tau_\delta \wedge T_{\partial B}^+] G_{\delta, \{z\}}^\omega(u, \partial B),
\end{aligned}$$

where

$$(8.10) \quad G_{\delta, \{z\}}^\omega(u, \partial B) = E_u^\omega \left[\sum_{n=0}^{\tau_\delta \wedge T_z} \mathbf{1}\{X_n \in \partial B\} \right] \leq |\partial B| \max_{v \in \partial B} G_{\delta, \{z\}}^\omega(v, v).$$

Since by Lemma 4.2, (2.5) and (4.1) we have for $\delta \geq 1/2$ and any $v \in \partial B$

$$(8.11) \quad G_{\delta, \{z\}}^\omega(v, v) = \pi^{\omega(\delta)}(v) R^\omega(v \leftrightarrow z \cup \delta) \leq \gamma_1 \max_{u \in \partial B} R_*^\omega[u \leftrightarrow z \cup \Delta].$$

Since $|\partial B| \leq \rho_d r^d$ adding up (8.9), (8.10) and (8.11) we get

$$\max_{u \in \partial B} P_u^\omega[T_z < \tau_\delta] \leq \gamma_2 r^d \max_{u \in \partial B} R_*^\omega[u \leftrightarrow z \cup \Delta] \max_{u \in \partial B} P_u^\omega[T_z < \tau_\delta \wedge T_{\partial B}^+].$$

Using the previous equation with (8.8) concludes the proof of the Proposition. \square

Recalling the notations from (2.1), (2.2) and (8.7), let us introduce

$$(8.12) \quad \underline{R}_*(y, k) = \begin{cases} \min_{u \in \partial B(y, k)} R_*^{\omega(y, k), 1}[u \leftrightarrow z \cup \Delta] & \text{if } z \notin B(y, k), \\ 1 & \text{otherwise,} \end{cases}$$

For the future decorrelation part we need to rewrite $\overline{R}_*^{\omega(y, r), 1}(y, r)$ in terms of $\underline{R}_*^\omega(y, r')$ and local quantities. This is done in the following lemma.

Lemma 8.1. *For any $B = B_E(y, r)$ and $r' \geq r$. Suppose that $z \in K_\infty(\omega)$ and $\partial B \cap K_\infty(\omega) \neq \emptyset$, we have*

$$\overline{R}_*^{\omega(y, r), 1}(y, r) \leq e^{4\lambda r'} \underline{R}_*^\omega(y, r') + C_{20} L_{y, r'}^{C_{21}} e^{C_{22} L_{y, r'}}.$$

Proof. Let us denote $v \in \partial B(y, r)$ such that

$$(8.13) \quad \max_{u \in \partial B(y, k)} R_*^{\omega(y, r), 1}(u \leftrightarrow z \cup \Delta) = R^{\omega(y, r), 1}(v \leftrightarrow z \cup \Delta) e^{2\lambda v \cdot \vec{\ell}},$$

applying Proposition 4.3 we get for any $r' \geq r$

$$(8.14) \quad \begin{aligned} R_*^{\omega(y, r), 1}(v \leftrightarrow z \cup \Delta) &\leq R^{\omega(y, r'), 1}(v \leftrightarrow z \cup \Delta) + C_1 L_{y, r'}^{C_2} e^{2\lambda(-y \cdot \vec{\ell} + L_{y, r'})} \\ &\leq R^{\omega(y, r'), 1}(v \leftrightarrow z \cup \Delta) + C_1 L_{y, r'}^{C_2} e^{2\lambda(-v \cdot \vec{\ell} + 2L_{y, r'})}, \end{aligned}$$

where we used that $y \cdot \vec{\ell} \geq v \cdot \vec{\ell} - r$ and that $L_{y, r'} \geq r' \geq r$ by the third property of Proposition 4.1.

For any $u \in \partial B(y, r')$, let us denote $i_0(\cdot)$ the unit current from u to $z \cup \{\Delta\}$ in $\omega_{(y, r'), 1}$ and \vec{Q} one of the shortest directed path from v to u included in $B(y, r')$. We can use Thompson's principle applied to the unit flow from v to $z \cup \{\Delta\}$ given by $\theta(e) = i_0(e) + (\mathbf{1}\{e \in \vec{Q}\} - \mathbf{1}\{-e \in \vec{Q}\})$ to get

$$(8.15) \quad R_{\omega_{(y, r'), 1}}(v \leftrightarrow z \cup \Delta) \leq R_{\omega_{(y, r'), 1}}^{z, \emptyset}(u \leftrightarrow z \cup \Delta) + 8r'e^{2\lambda(-y \cdot \vec{\ell} + r')},$$

where we skipped a simple exhaustion argument.

Hence adding up (8.14) and (8.15), we get

$$R_*^{\omega_{(y, r'), 1}}(v \leftrightarrow z \cup \Delta) \leq \min_{u \in \partial B(y, r')} R_*^{\omega_{(y, r'), 1}}(v \leftrightarrow z \cup \Delta) + \gamma_1(L_{y, r'})^{\gamma_2} \gamma_3^{L_{y, r'}} e^{-2\lambda y \cdot \vec{\ell}},$$

since $L_{y, r'} \geq r' \geq r$.

We get multiplying the left side by $e^{2\lambda v \cdot \vec{\ell}}$ and the right one by $e^{2\lambda r'} e^{2\lambda y \cdot \vec{\ell}}$ (which is greater than $e^{2\lambda v \cdot \vec{\ell}}$) that

$$R_*^{\omega_{(y, r'), 1}}(v \leftrightarrow z \cup \Delta) e^{2\lambda v \cdot \vec{\ell}} \leq e^{4\lambda r'} \underline{R}_*^{\omega}(y, r') + \gamma_4(L_{y, r'})^{\gamma_5} e^{\gamma_6 L_{y, r'}}$$

where we used that $\max_{u \in \partial B(y, r')} e^{2\lambda u \cdot \vec{\ell}} \leq e^{2\lambda r'} e^{2\lambda y \cdot \vec{\ell}}$. So by (8.13) we obtain the lemma. \square

8.2. Quenched estimates on perturbed Green functions. The aim of this subsection is to complete the first two steps of the sketch of proof at the beginning of Section 8. Let us introduce

$$(8.16) \quad R_*(z) = R_*^{\omega_{y, A}^{z, \emptyset}}(z) \text{ and } R_*(y) = R_*^{\omega_{y, A}^{z, e}}(y),$$

and this way we reduce our problem of studying Green functions to studying resistances, indeed using Lemma 4.1 and (6.2) we get for $\delta \geq 1/2$,

$$(8.17) \quad \frac{1}{\kappa_1} G_\delta^{\omega_{y, A}^{z, \emptyset}}(z, z) \leq R_*(z) \leq 2\kappa_1 G_\delta^{\omega_{y, A}^{z, \emptyset}}(z, z),$$

and

$$(8.18) \quad \frac{1}{\kappa_1} G_\delta^{\omega_{y, A}^{z, e}}(y, y) \leq R_*(y) \leq 2\kappa_1 G_\delta^{\omega_{y, A}^{z, e}}(y, y).$$

Moreover we can now easily obtain the first step of our proof since

$$(8.19) \quad G_\delta^{\omega_{y, A}^{z, \emptyset}}(0, z) G_\delta^{\omega_{y, A}^{z, e}}(z + e_+, y) \leq 4\kappa_1^2 P_0^{\omega_{y, A}^{z, \emptyset}}[T_z \leq \tau_\delta] P_{z+e_+}^{\omega_{y, A}^{z, e}}[T_y \leq \tau_\delta] R_*(z) R_*(y).$$

As mentioned before, we will apply recursively the resistance estimates of Proposition 4.2, for this we introduce

$$l_y^{(0)} = 1, \quad l_y^{(1)} = L_{y, 1}, \quad l_y^{(2)} = L_{y, l_y^{(1)}} \text{ and } l_y^{(3)} = L_{y, l_y^{(2)}},$$

$L_y^{(i)}(\omega) = l_y^{(i)}(\omega^{z,\emptyset}) \vee l_y^{(i)}(\omega^{z,e})$ and $B_y^{(i)} = B^E(y, L_y^{(i)})$. Moreover we set

$$Z_{y,k} = C_{23} k^{C_{24}} e^{C_{25}k} e^{2\lambda((z-y)\cdot\vec{\ell})^+} \text{ and } Z_y^{(i)} = Z_{y,L_y^{(i)}},$$

where and $C_{23} = 1 \vee C_1 \vee C_{19} \vee C_{20}$, $C_{24} = C_2 \vee C_{21} \vee 2d$ and $C_{25} = 4\lambda \vee C_{22}$. Moreover set, for $i = 0, \dots, 3$

$$(8.20) \quad R_*^{(i)}(y) = R_*^{\omega^{z,e}, B_y^{(i)}, 1}(y) \text{ and } R_*^{(i)}(z) = R_*^{\omega^{z,\emptyset}, B_y^{(i)}, 1}(z).$$

Also recalling (8.12), we set

$$\underline{R}_*^{(i)} = \underline{R}_*^{\omega^{z,\emptyset}}(y, L_y^{(i)}) \text{ and } \overline{R}_*^{(i)} = \overline{R}_*^{\omega^{z,\emptyset}}(y, L_y^{(i)}).$$

Finally we denote for $i = 1, 2, 3$ and $j = 0, 1, 2$

$$p_i^{(j)} = p_i^{\omega^{z,\emptyset}}(y, L_y^{(j)}) \text{ and } p_z^{(j)} = p_z^{\omega^{z,e}}(y, L_y^{(j)}).$$

In particular, since we assumed $Z_y^{(i)}$ large enough, we can get from Proposition 8.1 that for any $z \in \mathbb{Z}^d$ and $i \in \{0, 1, 2\}$,

$$(8.21) \quad P_0^{\omega^{z,e}, A}[T_z < \tau_\delta] \leq Z_y^{(i)} p_1^{(i)} p_2^{(i)} \overline{R}_*^{(i)} + 2P_0^{\omega^{z,e}, A}[T_z < T_{\partial B_y^{(i)}} \wedge \tau_\delta],$$

and also from Lemma 8.1 we obtain that for any $y, z \in K_\infty(\omega_{y,A}^{z,e})$, we have for any $i \leq j$

$$(8.22) \quad \overline{R}_*^{(i)} \leq Z_y^{(j)} \underline{R}_*^{(j)} + Z_y^{(j+1)}.$$

Moreover for $y, z \in K_\infty(\omega_{y,A}^{z,e})$, the random variables $Z_y^{(i)}$ are large enough for us to apply Proposition 4.2 so that we have for $i \in \{0, 1, 2\}$

$$(8.23) \quad R_*(z) \leq R_*^{(i)}(z) + Z_y^{(i+1)} \text{ and } R_*(y) \leq R_*^{(i)}(y) + Z_y^{(i+1)}.$$

The equations (8.21) and (8.22) yield that for any $y, z \in K_\infty(\omega_{y,A}^{z,e})$

$$(8.24) \quad P_0^{\omega^{z,e}, A}[T_z < \tau_\delta] R_*(z) R_*(y) \\ \leq \left(p_1^{(0)} p_2^{(0)} (Z_y^{(0)} \underline{R}_*^{(0)} + Z_y^{(1)}) + 2P_0^{\omega^{z,e}, A}[T_z < T_{\partial B_y^{(0)}} \wedge \tau_\delta] \right) R_*(z) R_*(y).$$

The idea is now to use recursively (8.23), (8.21) and (8.22) to control all the previous terms. We can obtain the following proposition

Proposition 8.2. *For any ω such that $y, z \in K_\infty(\omega_{y,A}^{z,e})$,*

$$\begin{aligned} \underline{R}^{(0)} R_*(z) R_*(y) &\leq C_{26} \left[\underline{R}_*^{(0)} R_*^{(0)}(z) R_*^{(0)}(y) \right. \\ &\quad + (Z_y^{(1)})^2 (\underline{R}_*^{(1)} R_*^{(1)}(z) + \underline{R}_*^{(1)} R_*^{(1)}(z) + R_*^{(1)}(z) R_*^{(1)}(y)) \\ &\quad \left. + (Z_y^{(2)})^4 (\underline{R}_*^{(2)} + R_*^{(2)}(z) + R_*^{(2)}(y)) + (Z_y^{(3)})^4 \right], \end{aligned}$$

and

$$R_*(z)R_*(y) \leq C_{27} \left[R_*^{(1)}(z)R_*^{(1)}(y) + Z_y^{(2)}(R_*^{(2)}(z) + R_*^{(2)}(y)) + (Z_y^{(3)})^2 \right].$$

This is an interesting upper bound since the resistances are only multiplied with independent local quantities, e.g. $Z_y^{(2)}$ is independent of $R_*^{(2)}(y)$, since $Z_y^{(2)}$ depends only on the “stopping time” $L_y^{(2)}$, i.e. only on the edges of $B^E(y, L_y^{(2)})$ by the second property of Proposition 4.1.

Proof. Let us prove the first upper bound, we use (8.23) to get

$$\begin{aligned} \underline{R}_*^{(0)} R_*(z)R_*(y) &\leq \underline{R}_*^{(0)}(R_*^{(0)}(z) + Z_y^{(1)})(R_*^{(0)}(y) + Z_y^{(1)}) \\ &\leq \underline{R}_*^{(0)} R_*^{(0)}(z)R_*^{(0)}(y) + Z_y^{(1)}(\underline{R}_*^{(0)} R_*^{(0)}(z) + \underline{R}_*^{(0)} R_*^{(0)}(y)) + (Z_y^{(1)})^2 \underline{R}_*^{(0)}. \end{aligned}$$

The first term of the right-hand side is of the form announced in the proposition. We need to simplify the remaining terms, we will continue the expansion for $\underline{R}_*^{(0)} R_*^{(0)}(z)$ (the method is similar for $\underline{R}_*^{(0)} R_*^{(0)}(y)$), using (8.23) and (8.22)

$$\begin{aligned} &\underline{R}_*^{(0)} R_*^{(0)}(z) \\ &\leq (Z_y^{(1)} \underline{R}_*^{(1)} + Z_y^{(2)})(R_*^{(1)}(z) + Z_y^{(2)}) \\ &\leq Z_y^{(1)} \underline{R}_*^{(1)} R_*^{(1)}(z) + Z_y^{(2)}(Z_y^{(1)} \underline{R}_*^{(1)} + R_*^{(1)}(z)) + (Z_y^{(2)})^2 \\ &\leq Z_y^{(1)} \underline{R}_*^{(1)} R_*^{(1)}(z) + (Z_y^{(2)})^2(Z_y^{(2)} \underline{R}_*^{(2)} + R_*^{(2)}(z) + 2Z_y^{(3)}) + (Z_y^{(2)})^2 \\ &\leq Z_y^{(1)} \underline{R}_*^{(1)} R_*^{(1)}(z) + (Z_y^{(2)})^3(\underline{R}_*^{(2)} + R_*^{(2)}(z)) + 3(Z_y^{(3)})^3, \end{aligned}$$

where we used that for any $i \leq j$ we have $1 \leq Z_y^{(i)} \leq Z_y^{(j)}$. All terms here are of the same type as in the proposition.

The expansion for the term $(Z_y^{(1)})^2 \underline{R}_*^{(0)}$ is handled by applying (8.22) for $i = 0$ and $j = 1$. Once again our upper bound is correct.

The second upper bound is similar and simpler since it uses only (8.23), so we skip the details. \square

Recalling the notations (8.3), (8.4) and (8.1) we have for $j \in \{z, 1, 2\}$

$$(8.25) \quad \text{for } y \in \mathbb{Z}^d \text{ and } k_1 < k_2, \quad p_j^\omega(y, k_1) \leq \rho_d k_2^{d-1} p_j^\omega(y, k_2),$$

so that for $k_1 < k_2 \in \{0, 1, 2\}$,

$$(8.26) \quad p_j^{(k_1)} \leq \rho_d Z_y^{(k_2)} p_j^{(k_2)}.$$

Finally let us take notice of the trivial inequality $P_0^\omega[T_z < T_{\partial B_y^{(0)}} \wedge \tau_\delta] \leq P_0^\omega[T_z < T_{\partial B_y^{(i)}} \wedge \tau_\delta]$ which used with (8.25) and Proposition 8.2 can expand (8.24). We can apply Proposition 8.2 can be applied since $y, z \in K_\infty(\omega_{y,A}^{z,e})$ if the integrand is positive. Then, imputing this expanded equation

into (8.19) and using (8.2) we can show that it is possible to give an upper bound on $G_\delta^{\omega_{y,A}^{z,\emptyset}}(0, z)G_\delta^{\omega_{y,A}^{z,e}}(z, y)$ with a finite sum of terms of the form

$$(8.27) \quad \mathbf{1}\{\mathcal{I}(\omega^{y,A})\}(Z_y^{(i)})^{C_{28}} p_z^{(i)} p_1^{(i)} p_2^{(i)} \underline{R}_*^{(i)} R_*^{(i)}(z) R_*^{(i)}(y),$$

and

$$(8.28) \quad \mathbf{1}\{\mathcal{I}(\omega^{y,A})\}(Z_y^{(i)})^{C_{28}} p_z^{(i)} P_0^{\omega_{y,A}^{z,\emptyset}} [T_z < T_{\partial B_y^{(i)}} \wedge \tau_\delta] R_*^{(i)}(y) R_*^{(i)}(z),$$

for $i \in \{0, 1, 2, 3\}$ and also similar terms where $\underline{R}_*^{(i)}$, $R_*^{(i)}(z)$ or $R_*^{(i)}(y)$ are possibly replaced by 1.

This is what we aimed for at the beginning of the proof of Proposition 7.2: the correlation term $Z_y^{(i)}$ is associated only with terms with which it is independent. Now we are only left with the third step of our proof that is the decorrelation part. Indeed, since we need to give an upper bound on $\mathbf{E}\left[G_\delta^{\omega_{y,A}^{z,\emptyset}}(0, z)G_\delta^{\omega_{y,A}^{z,e}}(z, y)\right]$, we shall look for an upper bound on the expectations of (8.27) and (8.28), which is the subject of the next sub-section.

8.3. Decorrelation part. Let us prove the first decorrelation lemma.

Lemma 8.2. *We have for $i \in \{0, 1, 2, 3\}$ and $\delta \geq 1/2$*

$$\begin{aligned} & \mathbf{E}\left[\mathbf{1}\{\mathcal{I}(\omega^{y,A})\}(Z_y^{(i)})^{C_{28}} p_z^{(i)} p_1^{(i)} p_2^{(i)} \underline{R}_*^{(i)} R_*^{(i)}(z) R_*^{(i)}(y)\right] \\ & \leq C_{29} \mathbf{E}\left[(L_y^{(i)})^{C_{30}} e^{C_{31} L_y^{(i)}}\right] \mathbf{E}\left[\mathbf{1}\{\mathcal{I}(\omega^{y,\emptyset})\} G_\delta^{\omega_{y,\emptyset}^{z,\emptyset}}(0, z) G_\delta^{\omega_{y,\emptyset}^{z,e}}(z + e_+, y)\right] e^{C_{32}((y-z)\cdot\vec{\ell})^+}, \end{aligned}$$

where C_{29} , C_{30} , C_{31} and C_{32} depend only on d and ℓ .

The same lemma holds, with different constants, if we replace $\underline{R}_*^{(i)}$, $R_*^{(i)}(z)$ or $R_*^{(i)}(y)$ by 1. Indeed it can be seen using Rayleigh's monotonicity principle that for $\delta > 1/2$, these three quantities are lower bounded by

$$1 \wedge R^{\omega_0}(0) \wedge \min_{k \in \mathbb{N}} \min_{u \in \partial B(0,k), z \notin B(0,k)} R_*^{\omega_0}(u \leftrightarrow z \cup \Delta) \geq \gamma_1,$$

where γ_1 can be chosen independent of y , i and z . By Lemma 4.2,

$$\begin{aligned} R_*^{\omega_0}(u \leftrightarrow z \cup \Delta) & \geq \gamma_1 G_{\delta, \{z\}}^{\omega_0}(u, u) = \gamma_1 P_u^{\omega_0}[T_u^+ < T_z \wedge \tau_\delta]^{-1} \\ & \geq P_u^{\omega_0}[\tau_\delta > 2, X_1 = y, X_2 = u]^{-1} \geq \gamma_1 \kappa_0^2/4, \end{aligned}$$

where y is some neighbour of u which is not z .

Proof. First let us notice that if the integrand is positive then $\mathbf{1}\{\mathcal{I}(\omega^{y,A})\} p_1^{(i)}$ is positive and necessarily $\left\{0 \leftrightarrow \partial B_y^{(i)}, 0 \stackrel{\omega_{y,A}^{z,\emptyset}}{\leftrightarrow} \infty\right\}$ which we denote $\{0 \Leftrightarrow y \Leftrightarrow \infty\}$, we recall $L_y^{(i)} < \infty$ by Proposition 4.1.

Let us condition on the event $\{L_y^{(i)} = k\}$ for $k < \infty$. First suppose that $0 \notin B(y, k)$, $z \notin B(y, k)$ and $z + e_+ \notin B^*(y, k)$, where we used a notation appearing above (8.1). Recalling the notations (8.1), (8.3) and (8.4), we may denote $x_0 \in \partial B^*(y, k)$ and $x_1, x_2 \in \partial B(y, k)$ such that

$$\begin{aligned} p_z^\omega(y, k) &= P_{z+e_+}^{\omega^{z,e}}[T_{x_0} = T_{\partial B^*(y,k)} < \tau_\delta], \\ p_1^\omega(y, k) &= P_0^{\omega^{z,\emptyset}}[T_{x_1} = T_{B(y,k)} < \tau_\delta], \\ p_2^\omega(y, k) &= P_{x_2}^{\omega^{z,\emptyset}}[T_z < \tau_\delta \wedge T_{B(y,k)}^+], \end{aligned}$$

where x_0 is connected to y in $B^E(y, k) \setminus [z, z + e]$ and we denote \mathcal{P}_0 one of the corresponding shortest such paths (hence of length $\leq k + 2$). Moreover let us set x_3 connecting $\partial B(y, k)$ to infinity without edges of $B(y, k)$. Thus

$$\begin{aligned} &\mathbf{E}\left[\mathbf{1}\{\mathcal{I}(\omega^{y,A})\}(Z_y^{(i)})^{C_{28}} p_z^{(i)} p_1^{(i)} p_2^{(i)} \underline{R}_*^{(i)} R_*^{(i)}(y) R_*^{(i)}(z) \mid L_y^{(i)} = k\right] \\ &\leq \gamma_1 k^{\gamma_2} e^{\gamma_3 k} e^{\gamma_4((z-y)\cdot\bar{\ell})^+} \mathbf{E}\left[\mathbf{1}\{0 \Leftrightarrow y \Leftrightarrow \infty\} p_z^{(i)} p_1^{(i)} p_2^{(i)} \underline{R}_*^{(i)} R_*^{(i)}(y) R_*^{(i)}(z) \mid L_y^{(i)} = k\right], \end{aligned}$$

where the integrand of the right-hand side depends only on the edges of $E(\mathbb{Z}^d) \setminus B^E(y, k)$, so that the conditioning is unnecessary.

Let us denote $\mathcal{P}_1, \mathcal{P}_2$ and \mathcal{P}_3 one of the shortest paths from respectively x_1, x_2 and x_3 to y and $\mathcal{P} = \mathcal{P}_0 \cup \mathcal{P}_1 \cup \mathcal{P}_2 \cup \mathcal{P}_3 \cup \{y + e, e \in \nu\}$. Hence we need to control

$$\begin{aligned} &\mathbf{E}\left[\mathbf{1}\{0 \Leftrightarrow y \Leftrightarrow \infty\} p_z^{(i)} p_1^{(i)} p_2^{(i)} \underline{R}_*^{(i)} R_*^{(i)}(z) R_*^{(i)}(y) \mid L_y^{(i)} = k\right] \\ &\leq \mathbf{E}\left[\mathbf{1}\{0 \Leftrightarrow y \Leftrightarrow \infty\} P_{z+e_+}^{\omega^{z,e}}[T_{x_0} = T_{\partial B^*(y,k)} < \tau_\delta] P_0^{\omega^{z,\emptyset}}[T_{x_1} = T_{\partial B(y,k)} < \tau_\delta] \right. \\ &\quad \times P_{x_2}^{\omega^{z,\emptyset}}[T_z < \tau_\delta \wedge T_{\partial B(y,k)}^+] R_*^{\omega^{(y,k),1}}[x_2 \leftrightarrow z \cup \Delta] R_*^{(0)}(z) R_*^{(0)}(y) \mid \mathcal{P} \in \omega\left. \right] \\ &\leq 2^{4k+4d+2} \mathbf{E}\left[\mathbf{1}\{0 \Leftrightarrow y \Leftrightarrow \infty\} \mathbf{1}\{\mathcal{P} \in \omega\} P_0^{\omega^{z,\emptyset}}[T_{x_1} = T_{\partial B(y,k)} < \tau_\delta] R_*^{(0)}(z) R_*^{(0)}(y) \right. \\ &\quad \times P_{x_2}^{\omega^{z,\emptyset}}[T_z < \tau_\delta \wedge T_{\partial B(y,k)}^+] P_{z+e_+}^{\omega^{z,e}}[T_{x_0} = T_{\partial B^*(y,k)} < \tau_\delta] R_*^{\omega^{z,\emptyset}}[x_2 \leftrightarrow z \cup \Delta]\left. \right], \end{aligned}$$

where we used that

- (1) $\mathbf{P}[\mathcal{P} \in \omega] \geq 2^{-(4k+4d+2)}$,
- (2) inequalities such as $P_{z+e_+}^{\omega^{z,e}}[T_{x_0} = T_{\partial B^*(y,k)} < \tau_\delta] = P_{z+e_+}^{\omega^{z,\emptyset}}[T_{x_0} = T_{\partial B^*(y,k)} < \tau_\delta]$,
- (3) Rayleigh's monotonicity principle yields, for example, that

$$R_*^{(i)}(y) \leq R_*^{(0)}(y) \text{ and } R_*^{\omega^{(y,k),1}}[x_2 \leftrightarrow z \cup \Delta] \leq R_*^{\omega^{z,\emptyset}}[x_2 \leftrightarrow z \cup \Delta].$$

Using (4.3) and $x_2 \in B(y, k)$, we get

$$P_{x_2}^{\omega^{z,\emptyset}}[T_z < \tau_\delta \wedge T_{\partial B(y,k)}^+] R_*^{\omega^{z,\emptyset}}[x_2 \leftrightarrow z \cup \Delta]$$

$$\begin{aligned}
&\leq \gamma_5 P_{x_2}^{\omega_{y,0}^{z,0}} [T_z < \tau_\delta \wedge T_{x_2}^+] \left(P_{x_2}^{\omega_{y,0}^{z,0}} [T_z \wedge \tau_\delta < T_{x_2}^+] \right)^{-1} \\
&= \gamma_5 P_{x_2}^{\omega_{y,0}^{z,0}} [T_z < \tau_\delta \wedge T_{x_2}^+ \mid T_z \wedge \tau_\delta < T_{x_2}^+] \\
&= \gamma_5 P_{x_2}^{\omega_{y,0}^{z,0}} [T_z < \tau_\delta],
\end{aligned}$$

moreover on ω such that $\mathbf{1}\{\mathcal{P} \in \omega\}$,

$$P_{x_1}^{\omega_{y,0}^{z,0}} [T_{x_2} < \tau_\delta] \geq (\delta\kappa_0)^{2k},$$

and putting these last two equations together we get

$$\begin{aligned}
&P_0^{\omega_{y,0}^{z,0}} [T_{x_1} = T_{\partial B(y,k)} < \tau_\delta] P_{x_2}^{\omega_{y,0}^{z,0}} [T_z < \tau_\delta \wedge T_{\partial B(y,k)}^+] R_*^{\omega_{y,0}^{z,0}} [x_2 \leftrightarrow z \cup \Delta] \\
&\leq \gamma_5 (\delta\kappa_0)^{-2k} P_0^{\omega_{y,0}^{z,0}} [T_{x_1} < \tau_\delta] P_{x_1}^{\omega_{y,0}^{z,0}} [T_{x_2} < \tau_\delta] P_{x_2}^{\omega_{y,0}^{z,0}} [T_z < \tau_\delta] \\
&\leq \gamma_5 (\delta\kappa_0)^{-2k} P_0^{\omega_{y,0}^{z,0}} [T_z < \delta].
\end{aligned}$$

In a similar way, we get by Markov's property that

$$P_{z+e_+}^{\omega_{y,0}^{z,e}} [T_{x_0} = T_{\partial B^*(y,k)} < \tau_\delta] \leq (\delta\kappa_0)^{-(k+2)} P_{z+e_+}^{\omega_{y,0}^{z,e}} [T_y < \tau_\delta].$$

Finally

$$\mathbf{1}\{0 \Leftrightarrow y \Leftrightarrow \infty\} \mathbf{1}\{\mathcal{P} \in \omega\} \leq \mathbf{1}\{\mathcal{I}\}.$$

Hence for ω such that $\mathcal{P} \in \omega$ we have

$$\begin{aligned}
&\mathbf{1}\{0 \Leftrightarrow y \Leftrightarrow \infty\} \mathbf{1}\{\mathcal{P} \in \omega\} P_0^{\omega_{y,0}^{z,0}} [T_{x_0} = T_{\partial B(y,k)} < \tau_\delta] P_{z+e_+}^{\omega_{y,0}^{z,e}} [T_{x_0} = T_{\partial B^*(y,k)} < \tau_\delta] \\
&\quad \times P_{x_2}^{\omega_{y,0}^{z,0}} [T_z < \tau_\delta \wedge T_{\partial B(y,k)}^+] R_*^{\omega_{y,0}^{z,0}} [x_2 \leftrightarrow z \cup \Delta] R_*^{(0)}(z) R_*^{(0)}(y) \\
&\leq \gamma_6 (2/\kappa_0)^{3k} \mathbf{1}\{\mathcal{I}\} P_0^{\omega_{y,0}^{z,0}} [T_z < \tau_\delta] P_{z+e_+}^{\omega_{y,0}^{z,e}} [T_y < \delta] R_*^{(0)}(z) R_*^{(0)}(y) \\
&\leq \gamma_7 e^{\gamma_8 k} \mathbf{1}\{\mathcal{I}\} G_\delta^{\omega_{y,0}^{z,0}}(0, z) G_\delta^{\omega_{y,0}^{z,e}}(z + e_+, y),
\end{aligned}$$

where we used Rayleigh's monotonicity principle to say that $R_*^{(0)}(y) \leq R^{\omega_{y,0}^{z,e}}[y \leftrightarrow \Delta]$, (8.17) and (8.18).

The result follows by integrating over all possible values of $L_y^{(i)}$, since we have just proved that

$$\begin{aligned}
&\mathbf{E} \left[\mathbf{1}\{\mathcal{I}(\omega^{y,A})\} (Z_y^{(i)})^{C_{28}} p_z^{(i)} p_1^{(i)} p_2^{(i)} \underline{R}_*^{(i)} R_*^{(i)}(z) R_*^{(i)}(y) \mid L_y^{(i)} = k \right] \\
&\leq \gamma_9 k^{\gamma_{10}} e^{\gamma_{11} k} \mathbf{E} \left[\mathbf{1}\{\mathcal{I}(\omega^{y,0})\} G_\delta^{\omega_{y,0}^{z,0}}(0, z) G_\delta^{\omega_{y,0}^{z,e}}(z + e_+, y) \right] e^{\gamma_{12}((y-z) \cdot \vec{\ell})^+}.
\end{aligned}$$

For the remaining cases, we proceed as follows

- (1) if $0 \in B(y, k)$, then we formally replace $P_0^\omega [T_x = T_{\partial B(z,k)} < \tau_\delta]$ by 1 for any $x \in \partial B(z, k)$ and x_1 by 0,

- (2) if $z + e_+ \notin B^*(y, k)$, then we formally replace $P_{z+e^+}^\omega [T_x = T_{\partial B^*(z, k)} < \tau_\delta]$ by 1 for any $x \in \partial B^*(z, k)$ and x_0 by $z + e^+$,
- (3) if $z \in B(y, k)$, then we formally replace $P_x^\omega [T_z = T_{\partial B(z, k)}^+ \wedge \tau_\delta]$ by 1 for any $x \in \partial B(z, k)$, $R_{*y, \emptyset}^{\omega_{z, \emptyset}} [x_2 \leftrightarrow z \cup \Delta]$ by 1 and x_2 by z ,

and the previous proof carries over with minor modifications. \square

We need another decorrelation lemma, which is essentially similar to the previous one but simpler to prove.

Lemma 8.3. *We have for $i \in \{0, 1, 2, 3\}$ and $\delta \geq 1/2$,*

$$\begin{aligned} & \mathbf{E} \left[\mathbf{1} \{ \mathcal{I}(\omega^{y, A}) \} (Z_y^{(i)})^{C_{28}} p_z^{(i)} P_0^{\omega_{y, A}^{z, \emptyset}} [T_z < T_{\partial B_y^{(i)}} \wedge \tau_\delta] R_*^{(i)}(y) R_*^{(i)}(z) \right] \\ & \leq C_{33} \mathbf{E} \left[(L_y^{(i)})^{C_{34}} e^{C_{35} L_y^{(i)}} \right] \mathbf{E} \left[\mathbf{1} \{ \mathcal{I}(\omega^{y, \emptyset}) \} G_\delta^{\omega_{y, \emptyset}^{z, \emptyset}}(0, z) G_\delta^{\omega_{y, \emptyset}^{z, e}}(z + e_+, y) \right] e^{C_{36}((y-z) \cdot \bar{\ell})^+}, \end{aligned}$$

where the constants depend only on d and ℓ .

Proof. Once again we condition on $\{L_y^{(i)} = k\}$ for $k < \infty$ and suppose that $0 \notin B(y, k)$ and $z \notin B(y, k)$, the other cases can be handled in the same way as before. We see that

$$\mathbf{1} \{ \mathcal{I}(\omega^{y, A}) \} \leq \mathbf{1} \{ 0 \Leftrightarrow y \Leftrightarrow \infty \},$$

and we denote $x_0, x_1 \in \partial B(y, k)$ such that

$$p_z^{(i)} = P_z^{\omega_{z, e}^{z, e}} [T_{x_0} = T_{\partial B(y, k)} < \tau_\delta],$$

and x_1 is connected to ∞ without edges from $B(y, k)$. Moreover denote \mathcal{P}_0 one of the shortest paths connecting x_0 to y and \mathcal{P}_1 one of the shortest paths connecting x_1 to y .

Then, using the same type of arguments as in the proof of Lemma 8.2, we get for $\mathcal{P} = \mathcal{P}_0 \cup \mathcal{P}_1 \cup \{y + e, e \in \nu\}$, on ω such that $\{L_y^{(i)} = k\}$,

$$\begin{aligned} & \mathbf{E} \left[\mathbf{1} \{ \mathcal{I}(\omega^{y, A}) \} (Z_y^{(i)})^{C_{28}} p_z^{(i)} P_0^{\omega_{y, A}^{z, \emptyset}} [T_z < T_{\partial B_y^{(i)}} \wedge \tau_\delta] R_*^{(i)}(y) R_*^{(i)}(z) \mid L_y^{(i)} = k \right] \\ & \leq \gamma_1 k^{\gamma_2} e^{\gamma_3 k} e^{\gamma_4((y-z) \cdot \bar{\ell})^+} \mathbf{E} \left[\mathbf{1} \{ 0 \Leftrightarrow y \Leftrightarrow \infty \} P_z^{\omega_{z, e}^{z, e}} [T_{x_0} = T_{\partial B^*(y, k)} < \tau_\delta] \right. \\ & \quad \left. \times P_0^{\omega_{y, A}^{z, \emptyset}} [T_z < T_{\partial B(y, k)} \wedge \tau_\delta] R_*^{(0)}(y) R_*^{(0)}(z) \mid \mathcal{P} \in \omega \right] \\ & \leq \gamma_1 k^{\gamma_2} 2^{2k+4d+2} e^{\gamma_3 k} e^{\gamma_4((y-z) \cdot \bar{\ell})^+} \mathbf{E} \left[\mathbf{1} \{ \mathcal{P} \in \omega \} \mathbf{1} \{ 0 \Leftrightarrow y \Leftrightarrow \infty \} \right. \\ & \quad \left. \times P_z^{\omega_{z, e}^{z, e}} [T_{x_0} = T_{\partial B^*(y, k)} < \tau_\delta] P_0^{\omega_{y, A}^{z, \emptyset}} [T_z < T_{\partial B(y, k)} \wedge \tau_\delta] R_*^{(0)}(y) R_*^{(0)}(z) \right]. \end{aligned}$$

Now on ω such that $\{\mathcal{P} \in \omega\}$, we have

$$P_0^{\omega_{y, A}^{z, \emptyset}} [T_z < T_{\partial B_y^{(i)}} \wedge \tau_\delta] = P_0^{\omega_{y, \emptyset}^{z, \emptyset}} [T_z < T_{\partial B_y^{(i)}} \wedge \tau_\delta] \leq P_0^{\omega_{y, \emptyset}^{z, \emptyset}} [T_z < \tau_\delta],$$

and

$$P_z^{\omega^{z,e}}[T_{x_0} = T_{\partial B^*(y,k)} < \tau_\delta](\delta\kappa_0)^k \leq P_{z+e_+}^{\omega^{z,\emptyset}}[T_y < \tau_\delta].$$

Since we also have $\mathbf{1}\{\mathcal{P} \in \omega\}\mathbf{1}\{0 \Leftrightarrow y \Leftrightarrow \infty\} \leq \mathbf{1}\{\mathcal{I}(\omega^{z,\emptyset})\}$ so that,

$$\begin{aligned} & \mathbf{1}\{\mathcal{P} \in \omega\}\mathbf{1}\{0 \Leftrightarrow y \Leftrightarrow \infty\} p_z^{\omega^{z,e}}(y,k) P_0^{\omega^{z,\emptyset}}[T_z < T_{\partial B(y,k)} \wedge \tau_\delta] \\ & \quad \times R_*^{(0)}(y) R_*^{(0)}(z) \\ & \leq \gamma_5 k^{\gamma_6} e^{\gamma_7 k} \mathbf{1}\{\mathcal{I}(\omega^{y,\emptyset})\} G_\delta^{\omega^{z,\emptyset}}(0,z) G_\delta^{\omega^{z,e}}(z+e_+,y), \end{aligned}$$

and the results follows by integration over the values of $L_y^{(i)}$. \square

Now, as we did to obtain the continuity of the speed, we need to show that the contribution due to the local modifications of the environment has a bounded effect. Hence we want to prove that the expectations appearing in Lemma 8.2 and Lemma 8.3 are finite for ε small enough. This is proved using the following lemma.

Lemma 8.4. *For ε_9 small enough and any $\varepsilon < \varepsilon_9$ we have*

$$\mathbf{E}[(L_y^{(3)})^{C_{30}+C_{34}} e^{(C_{31}+C_{35})L_y^{(3)}}] < C_{37},$$

where C_{37} depends only on d and ℓ .

Proof. Let us give an upper bound on the tail of $L_y^{(3)}$, we have

$$\begin{aligned} \mathbf{P}[L_y^{(3)} \geq n] & \leq \mathbf{P}[L_y^{(3)} \geq n, L_y^{(2)} \leq n/(2C_8)] \\ & \quad + \mathbf{P}[L_y^{(2)} \geq n/(2C_8), L_y^{(1)} \leq n/(2C_8)^2] \\ & \quad + \mathbf{P}[L_y^{(1)} \geq n/(2C_8)^2], \end{aligned}$$

and recalling Proposition 5.2 and Proposition 5.3 we get for $A = B(x,r)$

$$\mathbf{P}_{1-\varepsilon}[L_A(\omega) \vee L_A(\omega^{z,e}) \geq n + C_8 r] \leq 2C_9 r^d n \alpha(\varepsilon)^n,$$

so that we may use the second property of Proposition 4.1

$$\mathbf{P}[L_y^{(3)} \geq n] \leq 6C_9 \left(\frac{n}{2C_8}\right)^d n \alpha(\varepsilon)^{f(n)},$$

where $f(n) = (n/(2C_8)^2 - C_8)$ and $\alpha(\varepsilon)$ can be arbitrarily small if we take ε small enough. The result follows easily. \square

Now, Proposition 7.2 follows from the decomposition obtained at (8.27) and (8.28), the decorrelation part is handled by Lemma 8.2, Lemma 8.3 and the control on the multiplicative term appearing in these lemmas is upper bounded by Lemma 8.4 for ε small enough.

9. AN INCREASING SPEED

We want to prove Proposition 2.1, so let us find conditions for the walk to slow down when we percolate, i.e. $v_\ell(1) \cdot v'_\ell(1) > 0$. Let us denote $J(e) = (G^{\omega_0^{0,e}}(0,0) - G^{\omega_0^{0,e}}(e,0))$, we have

$$G^{\omega_0^{0,e}}(e,0) = P_e^{\omega_0^{0,e}}[T_0^+ < \infty \mid T_e^+ = \infty]G^{\omega_0^{0,e}}(0,0),$$

so that

$$G^{\omega_0^{0,e}}(0,0) - G^{\omega_0^{0,e}}(e,0) = P_e^{\omega_0^{0,e}}[T_0^+ = \infty, T_e^+ = \infty]G^{\omega_0^{0,e}}(0,0)G^{\omega_0^{0,e}}(e,e).$$

Then we use the classical property corresponding to Lemma 4.1 in the case where $\delta = 1$ (see [16]):

$$\text{for any } \omega \text{ and } z \in \mathbb{Z}^d, \quad R^\omega(z \leftrightarrow \infty)\pi^\omega(z) = G^\omega(z,z),$$

to obtain that

$$\begin{aligned} \frac{c(e)J(e)}{\pi^e} &= c(e)e^{2\ell \cdot e}R^{\omega_0^{0,e}}(0 \leftrightarrow \infty)R^{\omega_0^{0,e}}(e \leftrightarrow \infty)\pi^{-e}P_e^{\omega_0^{0,e}}[T_0^+ = \infty, T_e^+ = \infty] \\ &= c(e)e^{2\ell \cdot e}R^{\omega_0^{0,e}}(0 \leftrightarrow \infty)R^{\omega_0^{0,e}}(e \leftrightarrow \infty)\pi^\emptyset P_e^{\omega_0}[T_0^+ = \infty, T_e^+ = \infty], \end{aligned}$$

since $1 - p^\emptyset(e) = \pi^e/\pi^\emptyset$ and

$$(1 - p^\emptyset(e))P_e^{\omega_0^{0,e}}[T_0^+ = \infty, T_e^+ = \infty] = P_e^{\omega_0}[T_0^+ = \infty, T_e^+ = \infty].$$

By doing the previous reasoning backwards for the environment ω_0 , we get

$$(9.1) \quad \frac{c(e)J(e)}{\pi^e} = \frac{c(e)}{\pi^\emptyset} e^{2\ell \cdot e} (G^{\omega_0}(0,0) - G^{\omega_0}(e,0)) \frac{R^{\omega_0^{0,e}}(0 \leftrightarrow \infty)R^{\omega_0^{0,e}}(e \leftrightarrow \infty)}{R^{\omega_0}(0 \leftrightarrow \infty)^2}.$$

Now let us notice the symmetry relation

$$(9.2) \quad \begin{aligned} \beta(|e|) &:= \frac{1}{\pi^\emptyset} e^{2\ell \cdot e} \frac{R^{\omega_0^{0,e}}(0 \leftrightarrow \infty)R^{\omega_0^{0,e}}(e \leftrightarrow \infty)}{R^{\omega_0}(0 \leftrightarrow \infty)^2} \\ &= \frac{1}{\pi^\emptyset} e^{2\ell \cdot (-e)} \frac{R^{\omega_0^{0,-e}}(0 \leftrightarrow \infty)R^{\omega_0^{0,-e}}(-e \leftrightarrow \infty)}{R^{\omega_0}(0 \leftrightarrow \infty)^2}. \end{aligned}$$

Moreover have

$$(9.3) \quad \frac{\pi^e}{c(e)}(d_\emptyset - d_e) = \frac{\pi^e}{c(e)} \left(- \sum_{e' \neq e} \frac{c(e')c(e)}{\pi^\emptyset \pi^e} e' + \frac{c(e)}{\pi^\emptyset} e \right) = e - d_\emptyset.$$

Let us denote $H(e) = c(e)(G^{\omega_0}(0,0) - G^{\omega_0}(e,0))$, so that $(c(e)/\pi^e)J(e) = \beta(|e|)H(e)$. Now using the expression of $v'_\ell(1)$ given in Theorem 2.2, then

fact that $v_\ell(1) = d_\emptyset$ we can combine (9.1), (9.2) and (9.3) to get

$$\begin{aligned} v_\ell(1) \cdot v'_\ell(1) &= \sum_{e \in \nu} (d_\emptyset \cdot e) (G^{\omega_0^{0,e}}(0,0) - G^{\omega_0^{0,e}}(e,0)) (d_\emptyset - d_e) \cdot d_\emptyset \\ &= \sum_{e \in \nu} (d_\emptyset \cdot e) \beta(|e|) H(e) (d_\emptyset \cdot e - d_\emptyset \cdot d_\emptyset) \\ &= \sum_{i=1}^d \beta(|e^{(i)}|) \left[(d_\emptyset \cdot e^{(i)})^2 (H(e^{(i)}) + H(-e^{(i)})) \right. \\ &\quad \left. - (H(e^{(i)}) - H(-e^{(i)})) \|d_\emptyset\|^2 (d_\emptyset \cdot e^{(i)}) \right]. \end{aligned}$$

Hence for the previous quantity to be positive it suffices to show that each term of the sum is non-negative and that one term is positive, i.e. that for $i = 1, \dots, d$ such that $d_\emptyset \cdot e^{(i)} > 0$

$$(9.4) \quad \frac{H(e^{(i)}) + H(-e^{(i)})}{H(e^{(i)}) - H(-e^{(i)})} \geq \frac{\|d_\emptyset\|^2}{d_\emptyset \cdot e^{(i)}},$$

which a strict inequality for at least one index.

Moreover, using the reversibility of the random walk we have

$$\text{for } e \in \nu, \quad G^{\omega_0}(-e, 0) = \frac{\pi^{\omega_0}(0)}{\pi^{\omega_0}(-e)} G^{\omega_0}(0, -e) = \frac{c(e)}{c(-e)} G^{\omega_0}(e, 0),$$

so that $H(e^{(i)}) > H(-e^{(i)})$ for i such that $d_\emptyset \cdot e^{(i)} > 0$, thus the left-hand side of (9.4) is larger than one and the previous condition is verified if

$$\text{for } i = 1, \dots, d \text{ such that } d_\emptyset \cdot e^{(i)} > 0, \quad d_\emptyset \cdot e^{(i)} \geq \|d_\emptyset\|^2,$$

which proves Proposition 2.1. \square

ACKNOWLEDGEMENTS

I would like to thank my advisor Christophe Sabot for suggesting this problem and for his support.

My research was supported by the A.N.R. ‘‘MEMEMO’’.

REFERENCES

- [1] Alon, N., Spencer, J. and Erdős, P. (1992). *The Probabilistic Method*. Wiley, New York.
- [2] Ben Arous, G., Fribergh, A., Gantert, N. and Hammond, A. (2008). Biased random walks on Galton-Watson trees with leaves. arXiv:math/07113686.
- [3] Ben Arous, G. and Hammond, A.. Stable limit law for randomly biased walk on trees. In preparation.
- [4] Berger, N. and Biskup, M. (2007). Quenched invariance principle for simple random walks on percolation clusters. *Probab. Theory Relat. Fields.* **130** (1-2), 83–120.

- [5] Berger, N., Biskup, M., Hoffman, C.E. and Kozma, G. (2008) Anomalous heat-kernel decay for random walk among bounded random conductances. *Ann. Inst. H. Poincaré Probab. Statist.* **44** (2), 374–392.
- [6] Berger, N., Gantert, N. and Peres, Y. (2003). The speed of biased random walk on percolation clusters. *Probab. Theory Relat. Fields.* **126** (2), 221–242.
- [7] Chen, D. and Zhang, F. (2007). On the monotonicity of the speed of random walks on a percolation cluster of trees. *Acta Math. Sin..* **23** (11), 1949–1954.
- [8] Dhar, D. (1984). Diffusion and drift on percolation networks in an external field. *J. Phys. A.* **17** (5), 257–259.
- [9] Dhar, D. and Stauffer D. (1998). Drift and trapping in biased diffusion on disordered lattices. *Int. J. Mod. Phys. C.* **9** (2), 349–355.
- [10] Doyle, P.G. and Snell E.J. (1984). *Random walks and electrical networks*. Carus Math. Monographs **22**, Math. Assoc. Amer., Washington, D.C.
- [11] Garet, O. and Marchand, R. (2007). Large deviations for the chemical distance in supercritical Bernoulli percolation. *Ann. Probab..* **35** (3), 833–866.
- [12] Grimmett, G. (1999). *Percolation*. Second edition, Berlin: Springer.
- [13] Grimmett, G., Kesten, H. and Zhang, Y. (1993). Random walk on the infinite percolation cluster of the percolation model. *Probab. Theory Relat. Fields.* **96** (1), 33–44.
- [14] Kalikow, S.A. (1981). Generalized random walk in a random environment. *Ann. of Probab..* **9**, 753–768.
- [15] Lebowitz, J.L. and Mazel, A.E. (1998). Improved Peierls argument for high dimensional Ising models. *J. Stat. Phys..* **90** (3-4), 1051–1059.
- [16] Lyons, R. and Peres, Y. *Probability on trees and networks*. Available at <http://mypage.iu.edu/~rdlyons/prbtree/prbtree.html>
- [17] Lyons, R., Pemantle, R. and Peres, Y. (1998). Biased random walks on Galton-Watson trees. *Probab. Theory Relat. Fields.* **106**, 254–268.
- [18] Liggett, T.M., Schonmann, R.H. and Stacey, A.M. (1996). Domination by product measures. *Ann. Probab..* **24**, 1711–1726.
- [19] Mathieu, P. (2007). Quenched invariance principle for random walks among random conductances. To appear in *J. Stat. Phys..*
- [20] Mathieu, P. and Piatnitski, A. (2007). Quenched invariance principles for random walks on percolation clusters. *Proceedings A of the Royal Society.* **463**, 2287–2307.
- [21] Ruelle, D. (1969). *Statistical Mechanics. Rigorous Results*. New York: Benjamin.
- [22] Sabot, C. (2004). Ballistic random walks in random environment at low disorder. *Ann. of Probab..* **32** (4), 2996–3023.
- [23] Solomon, F. (1975). Random walks in a random environment. *Ann. of Probab..* **3**, 1–31.
- [24] Sznitman, A.-S. (2003). On the anisotropic random walk on the percolation cluster. *Com. Math. Phys..* **240** (1-2), 123–148.
- [25] Sznitman, A.-S. (2000). Slowdown and central limit theorem for random walks in random environment. *J. Eur. Math. Soc..* **2**, 93–143.
- [26] Sznitman, A.-S. (2004). *Topics in random walks in random environment*. School and Conference on Probability Theory, ICTP Lecture Notes Series, Trieste, **17**, 203–266.
- [27] Zeitouni, O. (2004). *Random Walks in Random Environment*, XXXI summer school in probability, St Flour (2001), *Lecture Notes in Math.* **1837**, pp. 193–312. Springer, Berlin.

UNIVERSITÉ DE LYON; UNIVERSITÉ LYON 1; INSA DE LYON, F-69621; ECOLE CENTRALE DE LYON; CNRS, UMR5208, INSTITUT CAMILLE JORDAN, 43 BLVD DU 11 NOVEMBRE 1918, F-69622 VILLEURBANNE-CEDEX, FRANCE

E-mail address: `fribergh@math.univ-lyon1.fr`