



HAL
open science

An Adaptation-based Approach to Incrementally Build Component Systems

Pascal Poizat, Gwen Salaün, Massimo Tivoli

► **To cite this version:**

Pascal Poizat, Gwen Salaün, Massimo Tivoli. An Adaptation-based Approach to Incrementally Build Component Systems. Proceedings of the International Workshop on Formal Aspects of Component Software (FACS 06), Sep 2006, Praha, Czech Republic. pp.155–170, 10.1016/j.entcs.2006.09.037 . hal-00342162

HAL Id: hal-00342162

<https://hal.science/hal-00342162>

Submitted on 14 Feb 2014

HAL is a multi-disciplinary open access archive for the deposit and dissemination of scientific research documents, whether they are published or not. The documents may come from teaching and research institutions in France or abroad, or from public or private research centers.

L'archive ouverte pluridisciplinaire **HAL**, est destinée au dépôt et à la diffusion de documents scientifiques de niveau recherche, publiés ou non, émanant des établissements d'enseignement et de recherche français ou étrangers, des laboratoires publics ou privés.

An Adaptation-based Approach to Incrementally Build Component Systems

Pascal Poizat

IBISC FRE 2873 CNRS - Université d'Évry, France
ARLES Project, INRIA Rocquencourt, France
Email: Pascal.Poizat@inria.fr

Gwen Salaün

VASY Project, INRIA Rhône-Alpes, France
Email: Gwen.Salaun@inria.fr

Massimo Tivoli

POPART Project, INRIA Rhône-Alpes, France
Università degli Studi dell'Aquila, Italy
Email: tivoli@di.univaq.it

Abstract

Software components are now widely used in the development of systems. However, incompatibilities between their behavioural interfaces may make their composition impossible. The objective of software adaptation is to compensate such incompatibilities building as automatically as possible corrective connectors or components. Constructing component-based systems from scratch is difficult, in particular when components cannot be used directly since they have to be adjusted with respect to their mates. Incremental construction methods are therefore essential because they make it possible to build systems step by step and therefore to master the complexity of their adaptation. In this paper, we propose an incremental approach to build component-based systems which relies on the generation of adaptors to overcome behavioural incompatibilities. The adaptation stage can be automated being given an abstract mapping formalising the properties of the system to be adapted.

Key words: Software Components, Behavioural Mismatch, Adaptation, Incremental Construction.

1 Introduction

Software components are now widely used in the development of systems, including embedded systems, Web services and distributed applications. The

This paper is electronically published in
Electronic Notes in Theoretical Computer Science
URL: www.elsevier.nl/locate/entcs

main challenges of Component-Based Software Engineering are composition, adaptation and verification of component applications. *Software adaptation* [16,7] aims at generating as automatically as possible component *adaptors*. Their role is to compensate incompatibilities appearing in a system constituted of communicating entities. It is now being accepted that components, and in particular their public interfaces – most of the time the only observable parts of components due to their black-box nature – have to take into account dynamic behaviours. In this paper, we deal with adaptors fixing incompatibilities at this behavioural level, *e.g.*, message name mismatch or deadlocking protocols.

Building a software system from scratch is a difficult task even if one of the promises of the component-based approach is to make the reuse of existing software entities easier. Moreover, composing components is a task which must take also into account adaptation of incompatible components. We propose an approach to build *incrementally* component-based systems, and where the generation of adaptors is fully automated if the software architect gives an abstract description of the properties of the system to be adapted, *i.e.*, an *adaptation mapping*.

In this context, the notion of Software Architecture assumes a key role since it represents the reference skeleton used to compose components and let them interact. The architecture proposed in our approach associates an adaptor to each component. If the component does not require adaptation, the adaptor (called a *no-op* adaptor) will reproduce from an external point of view exactly the same behaviour as the component. We build incrementally a system in such a way that it is able to evolve to architectural changes such as component addition or suppression. This architecture is very close to distributed systems and can be implemented using adaptive middlewares [1,12]. However our objective here is the automatic retrieval of the needed behavioural adaptor protocols, and not their implementation.

Our adaptor generation process is based on a former work using an expressive notation for the mapping (regular expressions of synchronous vectors), algorithms and tools [8]. Our focus here is on the incremental construction of a system made up of components and adaptors when the architect adds or removes one component. Our approach is interactive and the architect is informed on the state of the system-to-be before applying a modification (stable, addition of a new service, suppression of a service, etc). Most of the steps are completely automated, for instance to check the compatibility of interfaces, generate the adaptor, evaluate the correctness of the adaptor. Moreover, global approaches [16,13,5,15,8] which generate a global adaptor for the whole system have a main drawback being that recomputing the global adaptor every time something changes costs a lot. Accordingly incremental construction of adaptor-based systems is a solution to work them out.

The rest of the paper is organized as follows. Section 2 presents the formal model of components, and the architectural style we rely on. Section 3 focuses

on adaptation, and presents mechanisms to check if adaptation is needed, to compute adaptors, and to assess them. In Section 4, our approach for incremental construction involving components and adaptors is presented. We describe how the system is updated as automatically as possible when one component is added or removed. Section 5 illustrates our incremental approach on several case studies. We end in Section 6 with concluding remarks.

2 Component Systems

2.1 Component Interfaces

Component interfaces are given using a signature and a behavioural interface. A *signature* Σ is a set of operation profiles. This set is a disjoint union of *provided* operations and *required* operations. Behavioural interfaces are also taken into account through the use of *Labelled Transition Systems* (LTSs). A LTS is a tuple (A, S, I, F, T) where: A is an alphabet (set of event labels), S is a set of states, $I \in S$ is the initial state, $F \subseteq S$ are final states, and $T \subseteq S \times A \times S$ is the transition function. The alphabet of the LTS is built on the signature. This means that for each provided operation p in the signature, there is an element $p?$ in the alphabet, and for each required operation r , an element $r!$. Communication between two LTSs involves one event with complementary actions $p?/p!$.

Expressive behavioural languages such as process algebras can be used to define behavioural interfaces in a more concise way. For instance, the part of the CCS notation restricted to sequential processes is adequate to describe behavioural interfaces¹: $P ::= 0 \mid a?.P \mid a!.P \mid \tau.P \mid P1+P2 \mid A$, where 0 denotes a correct termination state, $a?.P$ a process which receives a and then behaves as P , $a!.P$ a process which sends a and then behaves as P , $\tau.P$ a process which evolves with the internal action τ and behaves as P , $P1+P2$ a process which may act either as $P1$ or $P2$, and A denotes the call to a process defined by an agent definition equation $A = P$. As process algebras do not enable to define initial and final states, we extend this CCS notation to tag processes with initial $[i]$ and final $[f]$ attributes. 0 and $0[f]$ being equivalent, we only use 0 in such a case.

2.2 Architectural Style

Components communicate by message passing in a peer-to-peer style. Connectors between components are simple communication channels defining a required and provided signature interface too. The required (*resp.*, provided) interface of a component may be connected to the provided (*resp.*, required) interface of one or more connectors.

¹ CCS descriptions can be translated into LTS models, which is especially necessary for computation purposes (see Section 3.2 about automatic generation of adaptors).

We will also distinguish between two kinds of entities: components and adaptors. Components implement the system’s functionality, and are the primary computational constituents of a system. Adaptors, on the other hand, route messages by following different coordination policies that depend on the adaptation to be performed whose properties are specified in an abstract way by the software architect.

Our architectural style considers systems in which distributed adaptors appear: it is referred as *Distributed Adaptor-Based Architecture* (DABA). A system is defined as a set of components each of them directly connected to its local adaptor; each adaptor is connected to other adaptors (one or many), through connectors, in a peer-to-peer fashion. Obviously a DABA may include the extreme case of an empty architecture where no component and, hence, no adaptor and connector are present. Such an empty architecture is the starting point of our incremental approach for building component-based systems.

We point out that connectors, and then the underlying communication model, are *synchronous*: two components synchronize on one event (rendez-vous) and then continue their own evolution. This notion is slightly different from the one existing in certain component-based development frameworks, such as COM/DCOM architectures [15] or BPEL for Web services [2]. In such models which inherit their communication features from object-oriented programming, communication is basically a method call or a remote procedure call (RPC). Therefore, the caller is waiting for the callee to terminate the required processing before continuing its own evolution. This is described in our model with two explicit messages, one for the request and another one corresponding to the acknowledgement. Asynchronous communication can be modelled describing message queues using additional components which interact synchronously with the components they represent.

3 Adaptation

Before defining methods to add and remove components, we present mechanisms to automatically check if a system needs adaptation (behavioural mismatch), the adaptor generation process, and means to evaluate the impact of the adaptation performed on the system.

3.1 Behavioural Mismatch

Various definitions of behavioural mismatch have been proposed in the field of software adaptation and Software Architecture analysis. We build on the most commonly accepted one, namely deadlock-freedom. Intuitively, a system made up of several identified components is deadlock-free, and therefore does not need any adaptation, if its synchronous product has no deadlock.

In a DABA style, components are viewed through their adaptors, consequently behavioural mismatch is computed taking adaptors as input instead of

components. It is not necessary in case of addition to consider the added component since interactions between this component and its adaptor are ensured correct by the algorithm used to build this adaptor.

Definition 3.1 [Synchronous Product] The *synchronous product* of n LTSs $L_i = (A_i, S_i, I_i, F_i, T_i)$, $i \in \{1, \dots, n\}$, is the LTS (A, S, I, F, T) such that:

- $A \subseteq \prod_{i \in \{1, \dots, n\}} A_i$, $S \subseteq \prod_{i \in \{1, \dots, n\}} S_i$, $I = (I_1, \dots, I_n)$,
- $F \subseteq \{(s_1, \dots, s_n) \in S \mid \bigwedge_{i \in \{1, \dots, n\}} s_i \in F_i\}$,
- T is defined using the following rule:
 $\forall (s_1, \dots, s_n) \in S, \forall i, j \in \{1, \dots, n\}, i < j$ such that
 $\exists (s_i, a, s'_i) \in T_i, \exists (s_j, \bar{a}, s'_j) \in T_j$, then
 $(x_1, \dots, x_n) \in S$ and $((s_1, \dots, s_n), (l_1, \dots, l_n), (x_1, \dots, x_n)) \in T$, where
 $\forall k \in \{1, \dots, n\}, l_k = \{ a \text{ if } k = i, \bar{a} \text{ if } k = j, \varepsilon \text{ otherwise} \}$
 $x_k = \{ s'_i \text{ if } k = i, s'_j \text{ if } k = j, s_k \text{ otherwise} \}$

The overline function on labels is defined as: $\overline{e?} = e!$, and $\overline{e!} = e?$.

Definition 3.2 [Behavioural Mismatch] An LTS $L = (A, S, I, F, T)$ presents a behavioural mismatch if there is a *deadlock state* s , *i.e.*, a state s in S , not in F and without outgoing transitions.

In practice, behavioural mismatch can be computed (i) encoding the set of LTSs in the EXP.OPEN input format [11], (ii) computing the product, and (iii) checking the absence of deadlocks on the resulting automaton. Note that to distinguish final states and real deadlocks within EXP.OPEN LTSs, we first add specific loop transitions labelled with `accept` over final states. Point (i) has been encoded in ADAPTOR, a prototype tool under development dedicated to the adaptation of software components. Points (ii) and (iii) are computed automatically calling CADP [9] which is a toolbox to validate and verify concurrent systems.

Example 3.3 Let us suppose three simple components: a client posting requests, a server receiving these requests and interacting with a counter every time a request is managed.

```
Client[i,f] = req!.args!.ack?.Client
Server[i,f] = req?.ack!.count!.Server
Adder[i,f] = add?.Adder
```

The product is computed and a deadlock is found out after the first transition $(\text{req!}, \text{req?}, \varepsilon)$ because the client wants to send arguments whereas the server wants to send him an acknowledgement.

3.2 Adaptors

In this section, we follow the adaptor generation process proposed in [8]. To check if a system made up of several components presents behavioural mismatch, the synchronous product [3] of their LTS behavioural interfaces is

computed and then the absence of deadlocks is checked on it. The protocol of an adaptor is given by an LTS which, put into a non-deadlock-free system yields a deadlock-free one. For this to work, the adaptor has to preempt all the component communications. Therefore, prior to the adaptation process, component message names may have to be renamed prefixing them by the component name, *e.g.*, `c:message!`.

In [8], we have proposed a mapping notation based on regular expressions of synchronous vectors as an abstract and simple description of the adaptor to be generated. Synchronous vectors express not only synchronization between processes on the same event names, but more general correspondences between the events of the process involved. A synchronous vector (or *vector* for short) for a set of n components LTSs $L_i = (A_i, S_i, I_i, F_i, T_i)$, $i \in \{1, \dots, n\}$, is a tuple $\langle e_1, \dots, e_n \rangle$ with $\forall j \in \{1, \dots, n\} e_j \in A_j \cup \{\varepsilon\}$; ε meaning that a component does not participate in a synchronization. Given n LTSs $L_i = (A_i, S_i, I_i, F_i, T_i)$, and a set of vectors V , a (vector) regex for these LTSs can be generated by the following syntax: $R ::= v$ (*vector*) | $R1.R2$ (*sequence*) | $R1+R2$ (*choice*) | R^* (*iteration*), where R , $R1$, $R2$ are regex, and v is a vector in V .

Using such a mapping and a list of component behavioural interfaces, an adaptor can be generated automatically using algorithms presented in [8] where we propose two kinds of adaptation, namely adaptation *with* or *without reordering*. Reordering (changing the order of events) is needed to ensure a correct interaction when two communicating entities have protocol messages which are not ordered as required. We emphasize that other algorithms can be used for adaptor generation purposes such as [5,13,15].

In case of adaptation without reordering, a synchronous product is computed from the LTS encoding the mapping regular expression (an LTS with vectors on transitions which recognizes the regex language) and component interfaces. Then, paths leading to deadlocks are removed [15], messages are mirrored (inputs in place of outputs, and vice-versa) to make communications with the adaptor possible, and finally, all the possible interleavings (starting by receptions then emissions) for every synchronisation described by a vector are generated to obtain the final LTS constituting the adaptor.

In case of adaptation with reordering, the idea is to encode, into a Petri net, mirrored component interfaces and correspondences between messages described in vectors as well as restrictions on the application order of vectors induced by the mapping regular expression. Then, the LTS of the adaptor is computed from the Petri net marking graph (non-recursive adaptors) or from its cover graph (recursive adaptors). Finally, paths to deadlock are removed, and the τ actions added during the Petri net encoding are suppressed using behavioural reductions.

Note that our algorithms are completely automated into a tool, ADAPTOR, which is under development. This tool relies on external tools, namely TINA [4] for marking and cover graph computation, and CADP [9] for synchronous

product computation and behavioural reductions.

Example 3.4 The behavioural mismatch detected in our simple client/server example is worked out by the mapping $(v1.v2.v3.v4)^*$ where

$$\begin{aligned} v1 &= \langle c:\text{req!}, s:\text{req?}, a:\varepsilon \rangle & v2 &= \langle c:\text{args!}, s:\varepsilon, a:\varepsilon \rangle \\ v3 &= \langle c:\text{ack?}, s:\text{ack!}, a:\varepsilon \rangle & v4 &= \langle c:\varepsilon, s:\text{count!}, a:\text{add?} \rangle \end{aligned}$$

The resulting adaptor computed using the algorithm without reordering sketched above is:

$$A[i, f] = c:\text{req?}.s:\text{req!}.c:\text{args?}.s:\text{ack?}.c:\text{ack!}.s:\text{count?}.a:\text{add!}.A$$

3.3 Assessment

Once a new adaptor is generated, we propose different means to assess the new system and make the architect sure that this system still contains all the expected services. Being given a set of components and their adaptors, the synchronous product is computed. Then, we propose several techniques to assess the adapted system.

First, the architect can check the system for services that have been achieved (internal, synchronised) or are still available (external, observable). Achieved services are deduced from labels (l_1, \dots, l_n) where there are at least two l_i different of ε . Available services are deduced from labels (l_1, \dots, l_n) where there is only one l_i different of ε .

Deadlock freedom can be checked on the adapted system as well. Let us recall that the generated adaptor is deadlock-free by construction. However, deadlock-freeness is preserved only with respect to the components with which the adaptor interacts, whereas the full system can still contain deadlocks. Consequently, when the last adaptor is computed using only a part of the components involved in the system, it is worth checking the absence of deadlocks on the full system (see Section 5 for illustration purposes).

4 Incremental Construction of Systems

In this section, we focus on the two main cases appearing while building a system, namely addition and suppression of components.

4.1 Addition of a Component

The method we propose can be viewed as an interactive assistant for the architect since it helps him step by step as a guide to build the system-to-be.

A first remark concerns both checks (behavioural mismatch and system assessment). They are not mandatory and are computed only if requested by the architect. The deadlock check may give back to the architect some blocking paths computed by CADP to help him to understand the problem and then write down the adaptation mapping needed to correct it.

Algorithm 1 (Add) *Inputs: system $S = \langle C_1, \dots, C_n, A_1, \dots, A_n \rangle$, component C to be added*

- (i) *check behavioural mismatch on $\langle C, A_1, \dots, A_n \rangle$*
 - (a) *no deadlock \rightarrow generate a no-op adaptor, and go to step (iv)*
 - (b) *deadlock \rightarrow adaptation needed, go to step (ii)*
- (ii) *get mapping M*
- (iii) *compute adaptor A from mapping M , component C and connected adaptors $A_{j \in I, I \subseteq \{1, \dots, n\}}$*
- (iv) *assess system $S' = \langle C_1, \dots, C_n, C, A_1, \dots, A_n, A \rangle$*
 - (a) *validated \rightarrow go to step (v)*
 - (b) *erroneous \rightarrow return to step (ii)*
- (v) *add C and A in S , and connect A to C and connected adaptors A_j*

The addition of a component does not always need protocol adaptation, *e.g.*, when adding the first component or when the test of mismatch does not detect a deadlock. However, our approach associates an automatically generated no-op adaptor to every component as in [15]. Such an adaptor basically reproduces from an external point of view the same behaviour as its component, and then routes messages from other adaptors to the component and vice-versa. More formally, the no-op adaptor construction for a process referred by p transforms respectively receptions and emissions as follows: $a? \rightsquigarrow p:a?.a!$, $a! \rightsquigarrow a?.p:a!$.

Step (iv)(b) takes into account two slightly different cases, since an erroneous system can be worked out either proposing a new mapping instead of the former one and then replacing the last adaptor, or keeping the last adaptor and proposing an additional mapping to build another adaptor to be connected on top of the previous one. We will illustrate such a situation in Section 5.2. Last, mappings have to be kept while building the system since in case of suppression, they may be modified and their corresponding adaptors updated.

4.2 Suppression of a Component

Removing a component induces the suppression of its corresponding adaptor, but also the possible update of all the components and adaptors interacting with it. Note that, in the worst case, this corresponds to recompute all adaptors which is as costly as the regular case in a non incremental approach where the centralized adaptor is recomputed for all components.

Step (i) is computed traversing all the mappings and detecting from the vectors the adaptors with which the component/adaptor to remove interacts. The two solutions proposed in step (ii) are complementary: in a first step, ε replace all the concerned labels in mappings, then the architect can update these mappings.

Algorithm 2 (Remove) *Inputs: system $S = \langle C_1, \dots, C_n, A_1, \dots, A_n \rangle$, component $C_k, k \in \{1, \dots, n\}$ to be removed*

- (i) *detect all the adaptors $A_{j \in I, I \subseteq \{1, \dots, n\}}$ connected to the adaptor A_k of component C_k*
- (ii) *update the mappings M_j of connected adaptors A_j : suppress all C_k labels into vectors and modify mappings M_j*
- (iii) *generate new adaptors A'_j off-line*
- (iv) *assess system $S' = \langle C_1, \dots, C_{i, i \neq k}, \dots, C_n, A_1, \dots, A_{i, i \neq k}, \dots, A_n \rangle [A'_j / A_j]$:*
 - (a) *validated \rightarrow go to step (v)*
 - (b) *erroneous \rightarrow return to step (ii)*
- (v) *remove C_k, A_k , and replace A_j by A'_j*

As regards complexity results, the most costly step in both previous algorithms is the computation of the adaptor which is exponential [8]. However, our approach can be applied to non-trivial systems as shown in Section 5.

5 Application

In this section we show our approach at work on three examples concerning respectively a Video-on-Demand system, the Dining Philosophers problem and a Music Player system.

5.1 The Video-on-Demand System

Our first example is a simplified version of the component-based Video-on-Demand (VOD) system described in [6]. We consider a client-server system formed by two kinds of components, one server component, called VOD, and one or more clients of VOD. The server VOD offers services to watch movies. If a client has not registered before, he can only preview movies. If a client has registered, he can view movies. In case of registered clients, the movie can be played directly or recorded (*i.e.*, the movie is first stored and played later on). Our objective, here, is to use adaptors to take into account the differences between registered and unregistered clients. The behavioural interfaces of VOD and its clients are the following:

```
VOD[i,f] = search?.list!.VOD + preview?.stream!.VOD
          + view?.(play?.stream!.VOD + record?.stream!.VOD)
Client[i,f] = menu!.info?.(watch!.data?.Client+store!.data?.Client)
```

Now, let us show how to build the VOD system incrementally by starting from an empty architecture (*i.e.*, no component and connector) and adding step by step new components. In Figure 1 we show the three steps of the incremental construction process that the architect wants to perform in order to incrementally build a VOD system formed by one VOD server and two clients. In the following we discuss each step in detail.

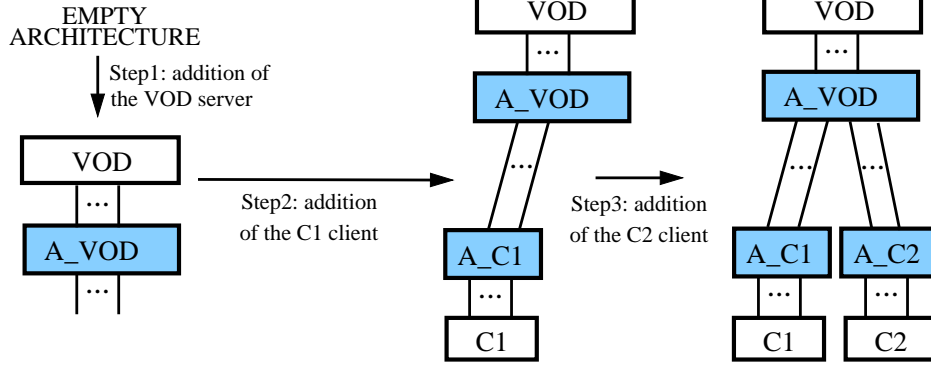

Fig. 1. Incremental construction of the VOD system

Initially, the system has no component and, hence, no connector. Let us suppose that the architect of the VOD system decides to add the `VOD` server. At this stage, no test of behavioural mismatch is required since the system is formed by a single component and, hence, a no-op adaptor is automatically generated. Let us denote this adaptor by `A_VOD`. It is worth mentioning that `A_VOD` has a strictly sequential input-output behaviour, *i.e.*, each input is followed by the corresponding output. Moreover, we recall that it will reproduce from an external point of view exactly the same behaviour as the component. In the following we show a portion of the `A_VOD` behavioural interface:

```
A_VOD[i,f] = vod:search?.search!.list?.vod:list!.A_VOD
           + vod:preview?.preview! ...
```

The adaptation evaluation (see Section 3.3) is skipped since there is only one component.

Let us suppose that an unregistered client is added, `C1`. It has the same behavioural interface as `Client` (shown above), *i.e.*, `C1 = Client`. In this situation, `VOD` and `C1` are incompatible since they use different action names (*e.g.*, `search` and `menu` actions do not match). Thus, the architect provides the following mapping that is used to generate `A_C1`, *i.e.*, the adaptor for `C1`:

```
M1 = (<c1:menu!,vod:search?> + <c1:info!,vod:list!> +
      <c1:watch!,vod:preview?> + <c1:store!,vod:preview?> +
      <c1:data?,vod:stream!>)*
```

By referring to Section 3.2, the mapping `M1` is a regular expression of synchronized vectors. It defines correspondences between the names of the actions performed by `C1` (*i.e.*, the ones with “`c1:`” as prefix) and by `A_VOD`. The actions `vod:view?`, `vod:play?` and `vod:record?` have no counterpart in the mapping, consequently no correspondence is specified for them. `M1` is a regular expression describing only a non-deterministic choice of vectors since there is no message ordering to be performed. From `A_VOD`, `C1` and `M1` the adaptor `A_C1` is automatically synthesized (using Section 3.2 mechanisms):

```
A_C1[i,f] = c1:menu?.vod:search!.vod:list?.c1:info!.
           (c1:watch?.vod:preview!.vod:stream?.c1:data!.A_C1
```

+ c1:store?.vod:preview!.vod:stream?.c1:data!.A_C1)

Next, the architect performs the external behaviour comparison between A_VOD and $(A_C1 \mid A_VOD)$, where “ \mid ” stands for the synchronous product of LTSs, and can observe that only actions `vod:view?`, `vod:play?` and `vod:record?` remain externally observable. Therefore, the architect confirms the addition of $C1$ (and its adaptor) in the system.

Let us suppose, now, that a $C2 = \text{Client}$ registered client is added. Analogously to the addition of $C1$, the architect can observe that $C2$ is incompatible with respect to VOD and, hence, the test of behavioral mismatch is skipped. The architect gives the following mapping to either match `watch` and `play` or `store` and `record`:

$$M2 = (v1.v2.(v3.v5.v7 + v4.v6.v7))*$$

with vectors:

```
v1=<c2:menu!,vod:search?>  v2=<c2:info!,vod:list!>
v3=<c2:watch!,vod:view?>   v4=<c2:store!,vod:view?>
v5=<c2:ε,vod:play?>        v6=<c2:ε,vod:record?>
v7=<c2:data?,vod:stream!>
```

From A_VOD , $C2$ and $M2$, an adaptor is automatically synthesized:

```
A_C2[i,f] = c2:menu?.vod:search!.vod:list?.c2:info!.
(c2:watch?.(vod:view!.vod:play!.A_C2' + vod:play!.vod:view!.A_C2')
+ c2:store?.vod:view!.vod:record!.vod:stream?.c2:data!.A_C2)
A_C2' = vod:stream?.c2:data!.A_C2
```

By referring to the behavioural interface of A_C2 , shown above, it is worth noticing that an adaptor does not always correspond to the specified mapping. In fact the mapping represents an abstract description of the adaptor that, once synthesized, can result in a more complex behaviour due to message interleaving (see, for instance, the two message sequences `vod:view!.vod:play!` and `vod:play!.vod:view!`). For this reason, the adaptor synthesis process deserves dedicated algorithms and tools such as the ones described in [8]. The architect performs again the external behaviour comparison between A_VOD and $(A_C2 \mid A_VOD)$, and can see that the single action visible from an external point of view is `vod:preview?` which is correct. By referring to Section 3.3, we recall that when the adaptor is computed using only a part of the components involved in the system, the adaptation evaluation process should also verify the presence of possible deadlocks in the full system. Thus, before adding $C2$ and its adaptor, the deadlock check on $(A_VOD \mid A_C1 \mid A_C2)$ is performed. Since no deadlock is detected, $C2$ is added and A_C2 is connected to the other components. Note that for this example component suppression is meaningless: either the architect removes a client (hence its corresponding adaptor) and it does not have any consequence on the system, or he/she removes the server and nothing works anymore.

5.2 The Dining Philosophers Problem

In this section, we consider a component-based system simulating the classical dining philosophers problem instantiated to the case of two philosophers and two forks. In order to eat, each philosopher needs both forks. In our model, we consider three kinds of components: `Fork`, `Phil1` and `Phil2`. The behavioural interface of `Fork` is the following:

```
Fork[i,f] = fork?.ok!.release?.Fork
```

`Phil1` and `Phil2` have different behavioural interfaces (they are given below). In the classical formulation of this problem, philosophers share the same behaviour which may cause a deadlock when they both interact to access the two forks. In this example we have simplified the classical formulation by isolating only the behaviour of each philosopher that may cause a deadlock, when both of them are present. The behavioural specifications of `Phil1` and `Phil2` are the following:

```
Phil1[i,f] = fo1!.ok1?.fo2!.ok2?.rel1!.rel2!.Phil1
Phil2[i,f] = fo2!.ok2?.fo1!.ok1?.rel2!.rel1!.Phil2
```

Without an adaptor the system (`f1:Fork | f2:Fork | Phil1 | Phil2`) deadlocks because action names do not match. Although an adaptor matching the different names can be inserted into the system, the two philosophers have also a mismatching interaction protocol. The system deadlocks whenever, *e.g.*, `Phil1` asks for and obtains the access to the first fork and then, `Phil2` asks for and obtains the access to the second fork. At this stage, both philosophers are blocked waiting for their complementary fork that will never be assigned to them.

The addition of the two `Fork` components `F1 = f1:Fork` and `F2 = f2:Fork` is done analogously to what we have done in Section 5.1 for the addition of the `VOD` server. The no-op adaptors of `F1` and `F2` are `A_F1` and `A_F2`, respectively.

In Figure 2 we show the two steps of the incremental construction process that the architect wants to perform in order to incrementally build a Dining Philosophers system made up of the two already added forks and two philosophers (*i.e.*, `Phil1` and `Phil2`). In the following we discuss these steps in detail.

Let us suppose that a `Phil1` component is added. `Phil1` is incompatible with respect to `F1` and `F2`. Thus, the following mapping `M1` is given:

```
M1 = (<phil1:fo1!, f1:fork?, f2:ε> + <phil1:ok1?, f1:ok!, f2:ε> +
      <phil1:rel1!, f1:release?, f2:ε> + <phil1:fo2!, f1:ε, f2:fork?> +
      <phil1:ok2?, f1:ε, f2:ok!> + <phil1:rel2!, f1:ε, f2:release?>)*
```

From `A_F1`, `A_F2`, `Phil1` and `M1` an adaptor `A_Phil1` is computed:

```
A_Phil1[i,f] = phil1:fo1?.f1:fork!.f1:ok?.phil1:ok1!.
               phil1:fo2?.f2:fork!.f2:ok?.phil1:ok2!.
               phil1:rel1?.f1:release!.phil1:rel2?.f2:release!.A_Phil1
```

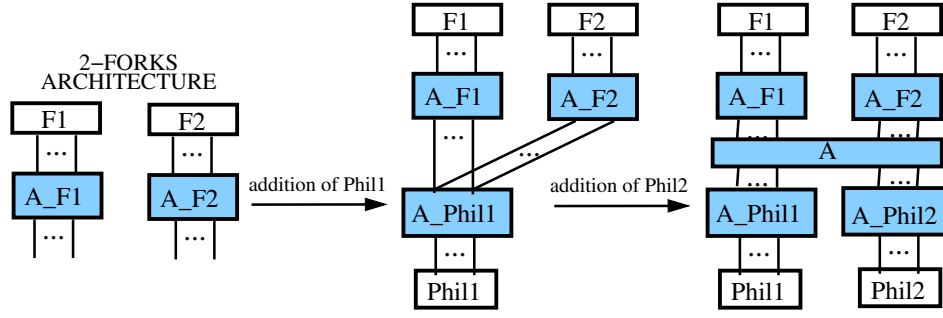

Fig. 2. Incremental construction of the Dining Philosophers system

Analogously to what we have done in Section 5.1, the adaptor is assessed and it is stated that the system $(A_F1 \mid A_F2 \mid A_Phil1 \mid phil1:Phil1)$ has no service lost (*wrt.* the services provided by F1 and F2). Thus, Phil1 and its adaptor are added.

Now, Phil2 has to be added. The addition of Phil2 is carried out analogously to the addition of Phil1 hence giving a mapping M2 and generating an adaptor A_Phil2 connected to Phil2, A_F1 and A_F2. This example points out an interesting application scenario of our approach. When the architect performs the deadlock check on the entire system, it is found out that $(A_F1 \mid A_F2 \mid A_Phil1 \mid A_Phil2)$ may deadlock. This deadlock comes from the mismatching interaction among Phil1 and Phil2 we mentioned in the beginning of this section. In this case the architect, before confirming the addition of Phil2 (and its adaptor), has to generate a new adaptor on top of both A_Phil1 and A_Phil2 in order to solve that deadlock. This adaptor is generated by taking into account A_Phil1, A_Phil2, A_F1, A_F2 and the mapping M3:

$$M3 = (\langle a_phil1:phil1:fo1!, a_f1:phil1:fo1?, a_f2:\varepsilon, a_phil2:\varepsilon \rangle + \langle a_phil1:phil1:fo2!, a_f1:\varepsilon, a_f2:phil1:fo2?, a_phil2:\varepsilon \rangle + \dots)^*$$

M3 can be automatically generated because the interface signatures of A_Phil1, A_Phil2, A_F1 and A_F2 match and no particular adaptation is required. In fact, it is only required to prune the traces leading to deadlocks in the global system (see Section 3.2). Let us denote the last generated adaptor by A. At this point the deadlock check is not needed since the architect knows that A is deadlock-free by construction and hence $(A_F1 \mid A_F2 \mid A_Phil1 \mid A_Phil2 \mid A)$ is deadlock-free as well. The architect confirms the addition of Phil2 and A_Phil2, and A is finally connected to A_F1, A_F2, A_Phil1 and A_Phil2.

5.3 The Music Player System

Last, we consider a component-based Hi-Fi system formed by four components: HF, TR, PDA1 and PDA2. HF controls an Hi-Fi station which can be asked to (i) play mp3 files, *i.e.*, `read?`, (ii) stop reading, *i.e.*, `halt?`, (iii) stop reading temporarily, *i.e.*, `pause?` and (iv) resume a temporary stop, *i.e.*,

resume?. Its behavioural interface is defined as follows:

```
HF[i,f] = read?.HFRead
HFRead = pause?.resume?.HFRead + halt?.HF
```

TR implements a translator which can (i) read an ogg file, *i.e.*, inogg? and (ii) convert it into a mp3 file, *i.e.*, outmp3!. Its behavioural interface is defined as follows:

```
TR[i,f] = inogg?.outmp3!.TR
```

PDA1 is a PDA which can, among other possible actions, ask the music system to (i) play a chosen mp3 file, *i.e.*, play!, (ii) stop playing, *i.e.*, stop!, (iii) stop the player temporarily, *i.e.*, pause! and (iv) resume a temporary stop, *i.e.*, resume!. Its behavioural interface is:

```
PDA1[i,f] = play!.PDA1PLAY
PDA1PLAY = stop!.PDA1 + pause!.resume!.PDA1PLAY
```

PDA2 is a different PDA which can, among other possible actions, ask the music system to (i) play a chosen file by means of the suitable player, *i.e.*, playmp3! or playogg! and (ii) stop playing, *i.e.*, stop!. We define its behavioural interface as:

```
PDA2[i,f] = playmp3!.stop!.PDA2 + playogg!.stop!.PDA2
```

The architect adds successively HF and TR. Two no-op adaptors, A_HF and A_TR, are generated. In Figure 3 we show the two remaining steps of the incremental construction process that the architect wants to perform in order to incrementally build a music player system formed by the two already added servers (*i.e.*, HF and TR) and two PDA clients (*i.e.*, PDA1 and PDA2).

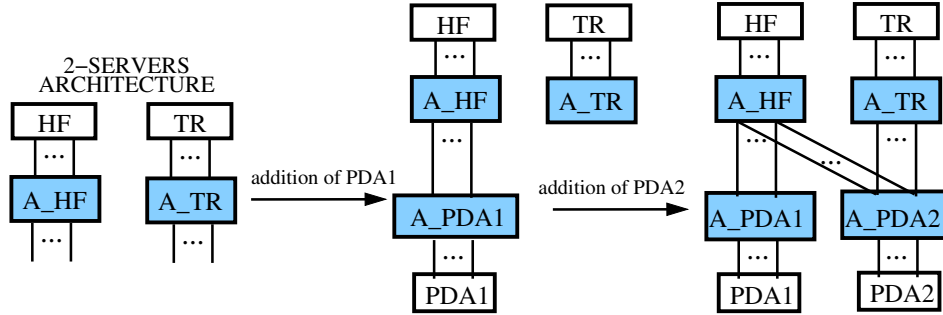

Fig. 3. Incremental construction of the Music Player system

Let us suppose that PDA1 is added. PDA1 deadlocks when interacting with HF. Thus, the following mapping is given:

$$M1 = (v1.(v3.v4)*.v2)*$$

with vectors:

```
v1=<pda1:play!,hf:read?>    v2=<pda1:stop!,hf:halt?>
v3=<pda1:pause!,hf:pause?>  v4=<pda1:resume!,hf:resume?>
```

From A_HF, PDA1 and M1 an adaptor is computed, A_PDA1:

```

A_PDA1[i,f] = pda1:play?.hf:read!.A_PLAY
A_PLAY = pda1:pause?.hf:pause!.pda1:resume?.hf:resume!.A_PLAY
         + pda1:stop?.hf:halt!.A_PDA1

```

The adaptation evaluation is performed, the system (A_HF | A_PDA1) has no service lost and, hence, the architect confirms the addition of A_PDA1 and PDA1 in the system.

Now, PDA2 is added. In the case of ogg files, TR has to be used to convert an ogg file into a mp3 file to be played using HF. The addition of PDA2 is carried out analogously to the addition of PDA1 hence giving a mapping M2 and generating an adaptor A_PDA2 connected to PDA2, HF and TR:

$$M2 = (v1.v4 + v2.v3.v4)*$$

with vectors:

```

v1=<pda2:playmp3!, hf:read?, tr:ε>
v2=<pda2:playogg!, hf:ε, tr:inogg?>
v3=<pda2:ε, hf:read?, tr:outmp3!>
v4=<pda2:stop!, hf:halt?, tr:ε>

```

and adaptor:

```

A_PDA2[i,f] = pda2:playmp3?.PLAY
             + pda2:playogg?.tr:inogg!.tr:outmp3?.PLAY
PLAY = hf:read!.pda2:stop?.hf:halt!.A_PDA2

```

The external behaviour comparison is performed and it indicates that (A_HF | A_TR | A_PDA2) has as observable actions only hf:pause? and hf:resume?. The architect confirms the addition of PDA2 and its adaptor.

As regards suppression, if either PDA1 or PDA2 is removed, its suppression is straightforward since there is no consequence on the system. If HF is removed, nothing works anymore since both PDA1 and PDA2 need to use it to accomplish their tasks. The only interesting case is when TR is removed since one required service of PDA2 will become unprovided by its environment. In this case, PDA2 can only play mp3 files and, hence, its adaptor has to be changed in order to not receive requests of playing ogg files anymore. This is done by replacing M2 by a new mapping M2' that computes an adaptor that does not perform the playogg action:

$$M2' = (v1.v4)*$$

with vectors

```

v1=<pda2:playmp3!, hf:read?> v4=<pda2:stop!, hf:halt?>

```

Let us denote by A_PDA2' the adaptor built by taking into account M2'. Checking the alphabet difference $A_{A_PDA2} \setminus A_{A_PDA2'}$, the architect is informed that the playing of ogg files on PDA2 is now observable. Depending on the system requirements this might be acceptable or not. If it is acceptable the architect confirms the suppression of TR and its adaptor, if not he/she may consider disconnecting PDA2 too. The A_PDA2 adaptor is replaced by A_PDA2' which

connects PDA2 to HF. Before confirming the A_PDA2' addition the deadlock check is performed on the system (A_HF | A_PDA1 | A_PDA2') to be sure that no deadlock is introduced. A_PDA2' is added since this check succeeds.

6 Concluding Remarks

In this paper, we have presented an interactive method to build incrementally systems made up of several communicating components viewed through their behavioural interfaces. This method is supported by a specific Software Architecture which avoids costly computation steps of building global adaptors when reconfiguring the system, if possible. In addition, most of the process steps are computed automatically: behavioural mismatch, adaptor generation, adaptor evaluation, updates of the system in case of suppression.

To the best of our knowledge, the closer works to ours are dedicated to incremental protocol enhancement. In [14] it is shown how to compose component wrappers to augment connector behaviour. In [15], the authors have revisited [14] providing approach automation. In [15], the starting point is a centralized adaptor that is always generated. Conversely to this, we try to solve mismatches by only producing local adaptors and we produce a centralized one only when it is unavoidable (*e.g.*, Dining Philosophers problem).

The main perspective of this work is to apply our approach to existing implementation languages and frameworks such as COM/DCOM architectures [10] or BPEL for web services [2].

References

- [1] Special Issue on Adaptive Middleware. *Commun. ACM*, 45(6):30–64, 2002.
- [2] T. Andrews et al. *Business Process Execution Language for Web Services (WSBPEL)*. BEA Systems, IBM, Microsoft, SAP AG, and Siebel Systems, February 2005.
- [3] A. Arnold. *Finite Transition Systems*. International Series in Computer Science. Prentice-Hall, 1994.
- [4] B. Berthomieu, P.-O. Ribet, and F. Vernadat. The tool TINA – Construction of Abstract State Spaces for Petri Nets and Time Petri Nets. *International Journal of Production Research*, 42(14), 2004.
- [5] A. Bracciali, A. Brogi, and C. Canal. A Formal Approach to Component Adaptation. *Journal of Systems and Software*, 74(1):45–54, 2005.
- [6] A. Brogi, C. Canal, and E. Pimentel. Component Adaptation Through Flexible Subservicing. *Science of Computer Programming*, 2006. To appear.
- [7] C. Canal, J. M. Murillo, and P. Poizat. Software Adaptation. *L'Objet. Special Issue on Software Adaptation*, 12(1):9–31, 2006.

- [8] C. Canal, P. Poizat, and G. Salaün. Synchronizing Behavioural Mismatch in Software Composition. In *Proc. of FMOODS'06*, volume 4037 of *LNCS*, pages 63–77. Springer-Verlag, 2006.
- [9] H. Garavel, F. Lang, and R. Mateescu. An Overview of CADP 2001. *EASST Newsletter*, 4:13–24, 2002.
- [10] P. Inverardi and M. Tivoli. Deadlock Free Software Architectures for COM/DCOM Applications. *Journal of Systems and Software*, 65(3):173–183, 2003.
- [11] F. Lang. Exp.Open 2.0: A Flexible Tool Integrating Partial Order, Compositional, and On-The-Fly Verification Methods. In *Proc. of IFM'05*, volume 3771 of *LNCS*, pages 70–88. Springer-Verlag, 2005.
- [12] P. K. McKinley, S. M. Sadjadi, E. P. Kasten, and B. H. C. Cheng. Composing Adaptive Software. *IEEE Computer*, 37(7):56–64, 2004.
- [13] H. W. Schmidt and R. H. Reussner. Generating Adapters for Concurrent Component Protocol Synchronization. In *Proc. of FMOODS'02*, pages 213–229. Kluwer Academic Publishers, 2002.
- [14] B. Spitznagel and D. Garlan. A Compositional Formalization of Connector Wrappers. In *Proc. of ICSE'03*, pages 374–384. ACM Press, 2003.
- [15] M. Tivoli and M. Autili. SYNTHESIS, a Tool for Synthesizing Correct and Protocol-Enhanced Adaptors. *L'Objet. Special Issue on Software Adaptation*, 12(1):77–103, 2006.
- [16] D. M. Yellin and R. E. Strom. Protocol Specifications and Components Adaptors. *ACM Transactions on Programming Languages and Systems*, 19(2):292–333, 1997.