



HAL
open science

Symbolic vs. iconic: How to support argumentative design discourse with 3D product representations

Onur Hisarciklilar, Jean-François Boujut

► **To cite this version:**

Onur Hisarciklilar, Jean-François Boujut. Symbolic vs. iconic: How to support argumentative design discourse with 3D product representations. IDMME - Virtual Concept 2008, Oct 2008, Beijing, China. pp.1-8. hal-00338229

HAL Id: hal-00338229

<https://hal.science/hal-00338229>

Submitted on 12 Nov 2008

HAL is a multi-disciplinary open access archive for the deposit and dissemination of scientific research documents, whether they are published or not. The documents may come from teaching and research institutions in France or abroad, or from public or private research centers.

L'archive ouverte pluridisciplinaire **HAL**, est destinée au dépôt et à la diffusion de documents scientifiques de niveau recherche, publiés ou non, émanant des établissements d'enseignement et de recherche français ou étrangers, des laboratoires publics ou privés.

Symbolic vs. iconic: How to support argumentative design discourse with 3D product representations

Onur Hisarciklilar¹ and Jean-François Boujut¹

(1) : G-SCOP Laboratory, Grenoble Institute of Technology
46 avenue Félix Viallet 38031 Grenoble, France

Phone : +33652568906

Fax : +33476574695

E-mail : {onur.hisarciklilar; jean-francois.boujut}@g-scop.inpg.fr

Abstract: This paper presents three technical design representation cases along with a real design case, in order to discuss how annotations should be used in 3D representations to support argumentative design communication. We distinguish between two modes of representations: iconic, where the signifier is perceived as resembling or imitating the signified, and symbolic, where the relationship between representation and target object is fundamentally arbitrary or purely conventional, so that the relationship must be learnt. The design cases are discussed according to this approach, in order to show how mode of representation of design artefacts has evolved according to the different sharing contexts, and the advantages that their modes offer respectively in their context of use. This analysis shows how iconic 3D representations must be enhanced by symbolic annotations, in order to support asynchronous argumentative design communication.

Key words: Annotations, design communication, symbolic and iconic representations, asynchronous collaboration, 3D product representations

1- Introduction

Annotation practices and their utilisation for supporting collective activities are ancient. According to Wolfe [1], medieval scholars were used to annotate the margins of manuscripts as a forum for sharing knowledge, debating readings of a text, and illuminating different reading strategies. Annotations were such important in reading practices that the books were often transcribed along with the annotations. The main reason of such practice was that the same copy of the document was shared by multiple readers.

As Wolfe [1] demonstrates, there is a similarity between that practice and the computer-supported annotation practices today. The collaborative document sharing tools offer to multiple participants today the possibility to collaborate and annotate around the same virtual document. That situation offers major advantages to the virtual communities, such as supporting the collaboration between members of distributed

teams [2], collective annotation of textual documents to decrease the reading time [3], or stimulating the decision making processes around documents [4].

The emergence of digital documents has also changed annotation practices in collaborative engineering design work. Virtual documents are very frequently used today between design participants to represent the design work, and network-based systems offer some functionalities to share these documents within the design team and enhance them with annotations. The positive effect of annotations on knowledge elicitation and team co-ordination have been already reported [5].

Moreover, concurrent engineering principles today requires the co-operative work of an increasing number of stakeholders from different domains of expertise, who have different design practices and different ways to represent their design work. Co-operative design processes requires deliberation and confrontation periods, during which design participants share the current design situation, and discuss collectively the design solutions, to elicit constraints and find alternative solutions to design problems. The co-operative design work may occur in synchronous situations, for example in design meetings, where participants discuss face-to-face or via videoconferencing tools. There is also an increasing need for asynchronous co-operation today, due to the geographic distribution of the design teams and the need to share and debate design representations earlier in the process [6].

3D product representations are more and more used today during these periods as common ground for participants; in order to reach a mutual understanding of design solutions. However, there is a very limited number of tools dedicated to support asynchronous design communication in order to support the collective evaluation of design problems. Actors often need to be provided with means for developing more systematic co-operation around product representations and more adapted information to the context of use.

The aim of this paper is to discuss how annotations should be used in 3D representations, in order to support argumentative design communication. We will first make an analysis between three technical representations. This analysis shows how mode of representation of design representations has evolved according to the different sharing contexts, and the advantages that their modes offer respectively in their context of use. Then we will analyse a real design case, based on our observations in an industrial vehicle company, in order to observe the annotation usage, and point out the annotation requirements.

2- Properties of semantic annotations

Semantic annotations can be described as annotations that are interpretable (or reusable) by a human being in a given context. In the Semantic Web domain, semantic annotations are intended primarily for use by machines to identify concepts and relations between concepts in documents to create 'intelligent documents', a document which "knows about" its own content in order that automated processes can "know what to do" with it [7]. The Semantic Web annotation frameworks, such as Annotea [8] or CREAM [9] intent to relate terms (e.g. dog) in a Web document to an ontology, to both abstract concepts (animal) or instances of abstract concepts (cat), in order to remove any ambiguity about the term.

Semantic Web annotation brings two kinds of benefits to the information systems, enhanced information retrieval and improved interoperability. Information retrieval is improved by the ability to perform searches, which exploit the ontology to make inferences about data from heterogeneous resources. Interoperability is particularly important for organizations, which have large legacy databases, often in different proprietary formats that do not easily interact. In these circumstances, annotations based on a common ontology can provide a common framework for the integration of information from heterogeneous sources.

Semantic annotations dedicated to human utilization, on the other hand, can be defined by their goals. The goal of an annotation in this context is the relation between object (information) and the action (the effect of the information). Zacklad argues [10] that annotations can either take the form of a proposal destined to be integrated into the main semiotic product, or they can be designed to express criticisms or to raise questions without being intended to remain a part of the main product, or they can be intended to be a perennial commentary on the main semiotic production process. Marshall [11] defines six types of annotations in collaborative reading according to their goal: annotations as procedural signals, annotations as place markings and aids to memory, annotations as in situ locations for problem-working, annotations as a record of interpretive activity, annotations as a visible trace of the reader's attention, and annotations as incidental reflections of the material circumstances.

Although the exact definition of an annotation is still controversial, it is possible to give a basic definition of the concept of semantic annotation by listing its properties and particularly by clearly distinguishing it from the concept of document.

Documents are graphical or textual representations (a report, a CAD model, etc.), created to accomplish a task in a given context. Although there may be other documents that can be used complementary to the main document, any document can be interpreted independently from other documents.

In contrast, annotations are attached to a document and can be interpreted only in the context of this document. Although they have this contextual relationship with the document, the goal behind their creation may differ from the goal of the entire document. Annotations are not all the time easy to detect especially when the documents are under construction.

The general properties of annotations in mechanical design context can be summarized as follows:

- An annotation has a different nature from the document on which it is attached to (for example representing non-geometrical information on a geometrical CAD object),
- The target is the object containing information that the annotation refers to. It can either be a document, (textual or graphical), a part of a document (a paragraph, a word or a part of an image), a collection of documents or another annotation. Annotations lifetime is always shorter than the targets lifetime.
- The content of an annotation is the information the annotation conveys. This can have various forms (such as textual or graphical) and can be situated in or out of the target document (such as a hyperlink pointing out an external document).
- The anchor of an annotation is the point onto the document, where the annotation is attached. Note that the form of the anchor of an annotation can also contain a semantic meaning.
- The sphere of influence of an annotation is defined by its personal or public status, i.e. whether the originator and the user of an annotation are different. The form of an annotation is closely related to its sphere, as they often require more effort to its creator to become interpretable to its users.

As we have seen, an annotation is only valid with the document it is attached to. The document constitutes therefore the context that makes it possible to understand the information that it conveyed by the annotation.

2.1- Objectives of annotation usage in design communication

From the different design situations that we observed, we concluded that the annotations are essentially used across two phases of the design process: asynchronous phase, where the digital artefact is produced, and synchronous phase, where the artefact is collectively evaluated.

An asynchronous situation is defined as a situation where a designer produces a CAD model of an object, or more generally a situation where an individual activity is carried out. In that case, notes can be produced individually in order to establish a list of decisions, remarks, explanations, etc.

making reference to a document (e.g. the CAD model). Annotated documents often remain private and can be used for several objectives, such as information indexation, or memorization of the current design situation, etc. Annotations are used in asynchronous situation to represent and capitalize information whose nature is not completely geometrical, such as a manufacturing process, or a type of material, etc.

The other engineering design situation when annotations are often used is a synchronous situation where a collective evaluation of the artefact is carried out. During this activity, intermediary documents are commented and annotated, mostly on a paper base. Today, these meetings are generally mediated by digital representations, and the distant actors communicate through instant messaging and/or video conferencing tools. During these activities, annotations are used mainly as a way to reinforce the oral discourse. Annotations created here are poorly structured and cannot be reinterpreted outside the context where they have been created. Therefore, the majority of annotations created during a design review cannot be reused during another one. All critics and argumentations are oral and nothing remains after the meeting apart from the personal notes taken by the participant of the review.

The design review is a place where solutions are discussed, and the points of view are expressed. Although these evaluations lead sometimes to alter the structure of the product, the solution is very seldom modified during these reviews. A minute is created during the meeting that records the main decisions and is supposed to help the designers during the asynchronous phase.

In conclusion, we consider that annotations have a major role for design coordination and knowledge elicitation in asynchronous phases, and an important cognitive synchronisation role in synchronous phases.

In the next section we make a comparison between three technical product representations, based on their modes of representation, as described by Pierce.

2- Modes of representation: Icons and symbols

The semioticien and philosopher Charles Sanders Peirce [12] proposes a three level typology of signs, which characterises the relationship between a sign (or signifier) and an object (signified, which the sign refers to): icons, symbols and indexes. For our purposes here, we will stress on the difference between an icon and a symbol.

For Pierce, an icon is the mode in which the signifier is perceived as resembling or imitating the signified (looking, sounding, feeling, tasting or smelling like it), being similar in possessing some of its qualities. A photograph of an apple, for instance, is an iconic representation, as it refers to it by having the same dimensional proportions, shapes, rendering and colour. Thus, the relationship between these two objects is physical and natural, rather than intellectual and cultural.

On the other hand, a symbol is a mode in which the signifier does not resemble the signified; it is, on the contrary,

fundamentally arbitrary or purely conventional, so that the relationship must be learnt. The language is the most typical example of symbolic representation. The words of a language have most of time any resemblances with the objects that they represent. For example, the word 'apple' contains any physical characteristics of the object of apple. And obviously, one should learn the significance of that word in advance in order to recognise this relationship.

Pierce adds that a signifier is never purely symbolic or iconic. It is always a mixture of these modes with different proportions. For example, even a photograph contains some conventions required to be correctly interpreted. A sign can also be a combination of several signs having different modes. The 'no smoking' sign is a typical example of this. The representation is composed from a cigarette drawing (which is rather iconic), encircled by a circle with an oblique bar, which is a very conventional way to represent an interdiction (Figure 1).



Figure 1: A typical no smoking sign combines symbolic and iconic representations

2.1- Modes of representation for design artefacts

Some typical design artefacts can be compared according to this point of view (Figure 2). For instance, a 3D CAD model as representation is mainly iconic. The tendency in 3D CAD representations is to look like as much as possible to the mechanical components that they represent, as the technology increases the level of details through photorealistic rendering techniques for example. There is still, however, a set of conventions to be learnt in order a 3D CAD model to be interpreted correctly.

Sketches, even if they are rather iconic, contain usually more convention than 3D CAD representations. There are often some parts in sketches (for example hatchings, doubled boundaries, coloured parts) drawn within rules other than resembling to the target object. The interpretation of these parts requires specific knowledge, related for example to a domain of expertise or a community of practice.

On the other hand, annotations are mainly symbolic representations. Whether they are graphical (e.g. an arrow representing the rotation movement of a component) or textual (e.g. an attached text on a representation describing a functionality), annotations require knowledge to be understood.

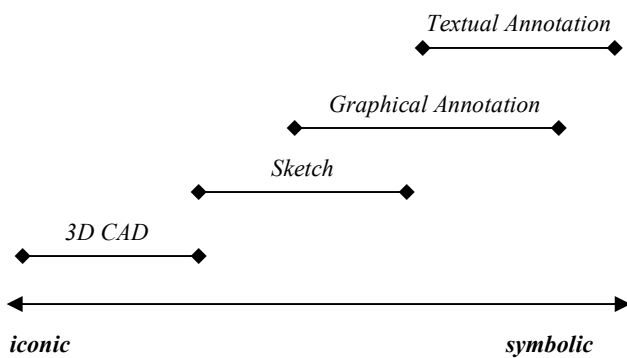

Figure 2: Modes of representation for design artefacts

In the following, three cases of graphical representations will be discussed, according to the mode of representation point of view. The objective is to point out the advantages and limitations that iconic and symbolic representations bring to designers.

2.2- The Diderot and d’Alembert Encyclopaedia case

According to [13], the Encyclopaedia is not the first work that meant to explain and share the know-how about mechanical products. But it is often considered as an important milestone about the way to represent that know-how. The first particularity of Encyclopaedia is its considerable effort to offer a complete vision about the productive activity. The work tends to explain the raw materials, the different ways to use the product, and also the techniques employed to produce it. Therefore, Encyclopaedia is about both products and processes.

The second reason that characterises the Encyclopaedia is the instruments that it employs in order to describe the know-how: graphical representations. As the authors, Diderot and d’Alembert state, the graphics has been chosen as the main way of description in Encyclopaedia. Besides, the eleven volumes of the work published between 1762 and 1772 contain approximately 2800 graphical representations, with textual descriptions associated. The importance of graphical representations has been described by Diderot in the introduction of Encyclopaedia as:

“The absence of habit about reading and writing texts on arts makes things difficult to express in an intelligible way. That’s where the need for figures arises. We could have presented them by thousands of purely textual examples. However, no matter how well they have been written, without figures they would inevitably be obscure and vague. (...) A look on an object or on its representation says much more than a long page of text.”

The choice of graphical representation has been done as a practical approach, aims to facilitate the understanding of descriptions, and to deal with the ambiguity that a textual description may occur. This approach has been conserved until early 20th century as the way to prescribe the production techniques, for their recording and reproduction.

The graphical representations in the Encyclopaedia are highly symbolic. These are 3D drawings, which follow natural perspective rules, and contain shadows and rendering close to actual photorealistic rendering techniques (Figure 3). That mode of representation has been chosen to eliminate all possible conventions, in order the representations to request as less technical knowledge as possible. This is an inevitable choice, when the large diffusion periphery of these representations and the lack of representation standards are taken into consideration.

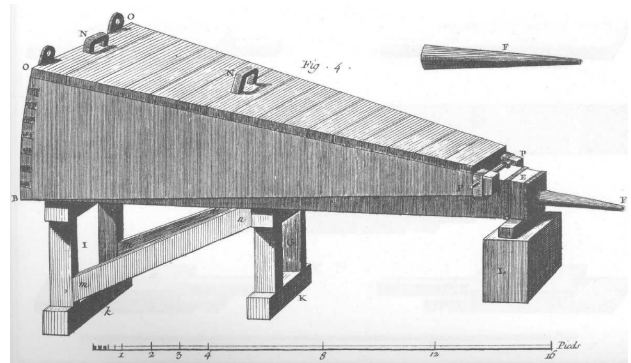

Figure 3: Detail from a drawing in Encyclopaedia [14].

On the other hand, the graphical representations in the Encyclopaedia contain also some symbols that support the graphical expression. The first one, which is considered as one of the main innovations in Encyclopaedia, is usage of a scale on the bottom of all figures, which indicate the real dimensions of the objects (Figure 3, bottom). The second one is the ‘fig’ word with a number, found on each of the parts of the representation, which locates the title and the textual comment associated to the part. The comment usually concerns information that cannot be represented by a drawing, such as raw materials, functionalities, or information related to the production processes.

Graphical representations on the Encyclopaedia case show the importance of iconic representations usage to communicate graphical information within large groups. These representations offer the possibility to interpret this information without important pre-required knowledge about specific drawing rules. On the other hand, conventional representations (text here) are often required in order to interpret these representations, as iconic representations are incompatible to represent information of non-geometrical nature.

2.3- The 2D case

The emergence of 2D projection representations is the consequence of the industrial age, which caused several evolutions in design products and organisation of the design team, such as increasing complexity of products, decreased tolerances, emergence of new production technologies, or the segmentation of expertises related to the design and the production. These changes has requested the use of representations more precise, able to contain more information (e.g. about tolerances or production technologies), which could be an effective and unambiguous

way to communicate design information, especially between designers and producers.

As from 60's, 2D drawings are supported by the first CAD systems, which has provided designers with a convenient way to represent 2D drawings based on a variety of 2D geometric elements and annotation methods to define product shapes and tolerances.

The first major change is doubtlessly the act of drawing 2D projections of design products. That method provides designers the ability to draw with more precision and use cross sections, to be able to represent more information on the representation, and reduce the ambiguity.

The second important change is the standardisation of forms. Both the rules to draw mechanical parts, and symbols used to represent additional information such as dimensions or production technologies have become highly standard. The objective is to improve the quantity of information represented, and to deal with the ambiguity.

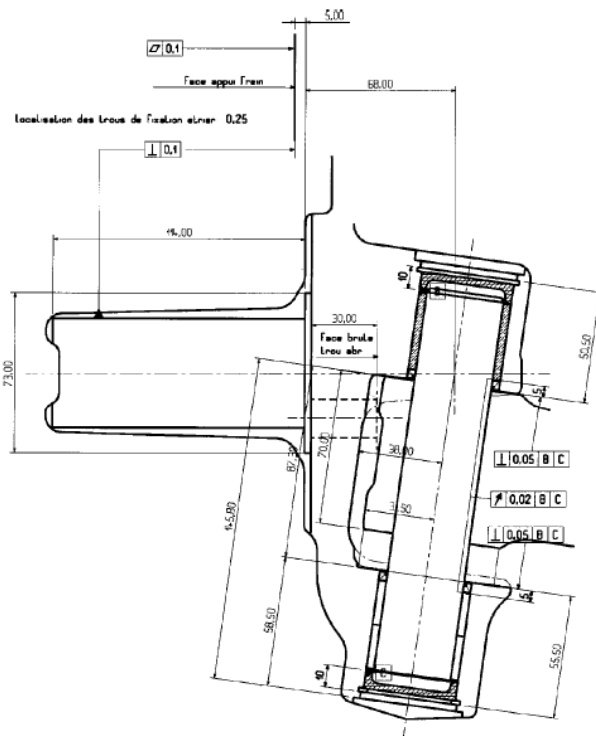

Figure 4: Example of a 2D drawing [15].

Thus, the 2D drawings have evolved to be highly conventional and symbolic (Figure 4). The main advantage of these drawings is that they are subject to a rich and accurate communication between design actors, thanks to their standardised forms and drawing rules. These symbols can be considered as a local language between these actors, in a sense that they cover a set of entities representing specific design information. Note that there is no 3D equivalent representation system that supports this information; therefore 2D drawings are still preferred in many design situations.

As said before, the symbolic nature of these representations require specific knowledge for their interpretation. The

inevitable consequence of that, is the limited number of actors in a company who can use it to communicate. The 2D plans are traditionally used between engineers or from the design engineers to the manufacturing department.

2.3- The 3D CAD case

As discussed above, 2D CAD provided effective methods to create 2D drawings, with many advantages to define and represent non-geometric design information.

On the other hand, 2D drawings have several major limitations. Firstly, 2D drawings are limited to represent complex product models, which are error-prone. Secondly, an important level of skill is needed to construct and interpret these drawings. When complex product models are concerned, construction and interpretation becomes time consuming.

Basic 3D modeling techniques, such as surface modeling and solid modeling, have been developed from the late 70's, to provide designers with the means to represent complex mechanical components, which cannot be accurately represented on a 2D drawing. 3D CAD was also a means to diminish the need for producing mock-ups. The 3D CAD is able to substitute mock-ups in many circumstances, which makes design team save time and effort.

The mode of representation of 3D CAD opposes to the 2D drawings. The main approach of 3D CAD is to represent the product with forms and curves as resembling as possible to the product. 3D has evolved to represent the product with ability to add photo-realistic effects, such as surface rendering or shadow effects. Many symbolic representation techniques in 2D drawings related to its planar nature, such as cross sections, are not needed any more in 3D. Moreover, specific forms of annotations, especially those related to the manufacturing process, are less employed in 3D CAD (Figure 5).

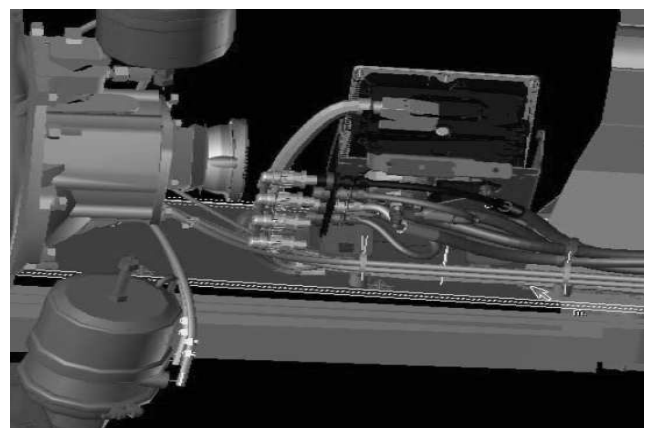

Figure 5: 3D drawing of truck components.

That particularity of 3D CAD makes it an important artifact in the collaborative work. One of the important evolutions in the collaborative design work was the emergence of the concurrent engineering principles. The increasing complexity of products and the number of fields of expertise associated to this complexity involved co-operative work of an

increasingly high number of stakeholders from different fields of expertise during the design process. In the co-operative situations, where common representations are required in order for the stakeholders to reach a common understanding of the ongoing design and communicate through the representation, 3D CAD models are frequently used. Therefore 3D CAD models offer the stakeholders that common iconic representation base, where each of them can interpret the same product representation, and engage a discussion.

Thus, the iconic nature of the 3D CAD models naturally provide an important artifact for co-operation, and an instrument for integration [15], which can support argumentation and common understanding between participants from different departments.

In the following, we present a design case, based on our observations in the leading industrial vehicle company in France. Our objective is to observe a co-operation case where 3D representations are employed as the main communication artifacts. We will track the need of designers to enrich these representations with symbols in order to enhance the communication. We will then discuss how this need can be satisfied in asynchronous situations.

2- A design case

In this section, we will make a description of a co-operative design case, based on our field study in an industrial vehicle company. We particularly stress on the information sharing in the asynchronous and synchronous phases of the process, and we point out the need for adding symbolic elements to 3D representations. In the next section, we will show how annotations may constitute an effective solution.

2.1 The design team

The cross-domain team we consider here is led by an architect. With his high technical level, he coordinates the design activities of an entire sub-system of the truck. He communicates with the designers during asynchronous phases of the project in order to assess geometrical conformity and also coordinates the design reviews. He is responsible for the design solution. The actor called PMS (Project Management Support) works with the architect and is in charge of short-term operational management of the project. During the asynchronous phases, he manages and communicates information about the studies in progress (such as deadlines, types of vehicles impacted by each study, etc.). He is also in charge of the design review minutes. The “designers” are technical actors who develop solutions in the CAD environment during the asynchronous phases. Another kind of actor, called “screenwriter” supports the architect by maintaining and updating the digital mock-up. Other actors, called “industrialists” are specialists from different domains (manufacturing, SAS, quality, etc.). They participate in the design reviews in order to evaluate the design solution with regard to their specific knowledge.

2.2 An asynchronous design phase

We have seen earlier that the asynchronous phase was the period when the designers were developing a technical solution. This activity requires technical knowledge and skills. We highlight the fact that the solution is developed mainly according to the individual decisions of the designer, on the basis of his own knowledge of the context and decisions taken during the previous meetings.

Although this is an individual activity, the designer needs sometimes to collaborate with the other actors, especially with the technical actors (the architect, the screenwriter, or other designers). Communication during these unplanned events is made in an unstructured way (face-to-face meetings, telephone calls or email exchanges). They are means to debate or unofficially validate a design solution proposition. However important decisions can be made at that time.

When the model is completed, the screenwriter integrates this instance into the shared CAD environment. In other words, from that particular moment, the model (the solution) becomes accessible to the other actors, until the next design review.

2.3 A synchronous design phase: the design review

The design reviews were originally dedicated to control the process (the procedure defines them as decision points only). However, the stakeholders took the opportunity of these regular meetings to debate on the solution, as there was no other formal design meetings dedicated to that activity in the general design process organisation. This implies that the creative input of a design review is not as secondary as it may seem. It is a place where key decisions and their rationale are made explicit. In our case, as the participants do not have the opportunity to access information about the design decisions before, design reviews become the unique event when participants are able to exchange arguments about the design solution and make new propositions.

During a design review, first the designer presents the design solution that he produced. It is an oral presentation, where he gives all the information that cannot be represented on the CAD model (rationale behind the decisions that he made, key points of the solution, etc.). Then, the participants discuss the solution. That is the phase where domain-specific rules are made explicit, and key decisions are made.

The design minute is constructed simultaneously by the PMS within this discussion phase. When a decision is made or an action is decided, he takes a screenshot of the projected screen on his PC, and takes note of the decision or the action by annotating the screenshot. The other actors cannot see the PMS's notes during the design review, in other words, they have not the opportunity to share and evaluate these annotations. Finally, the design minute is transformed into a pdf document composed of a series of annotated screenshots. The annotations are of textual nature, anchored to a point on the image by an arrow (Figure 6). After the review, this document is stored on a shared database, and remains accessible to all the participants.

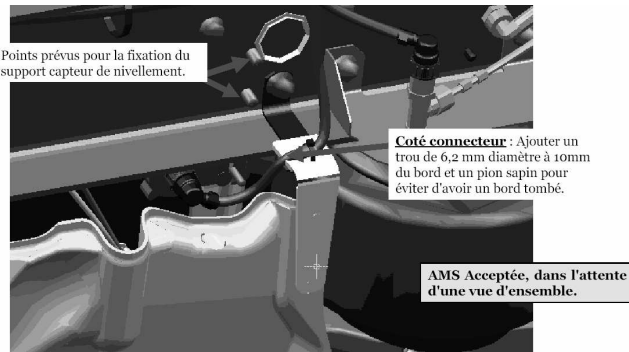

Figure 6: An annotated screenshot in a design minute.

Design reviews are the only moments where the designers, the architect, the PMS and the industrials meet together in order to collectively evaluate the current solution. The CAD model is used to visualise the solution and the main co-operation artefact shared during the design review. The minute is the only shared document after the design review and is composed of static annotated screenshots.

This design case illustrates several important points for our interests: Firstly, the 3D CAD constitutes the main co-operation artefact that enables argumentative discussions between participants from diverse domains. Every participant is able to interpret the 3D representation during the design review. Second important point is that it is crucial during the co-operative situations that designer presents the design solution (by explaining important rational information, design constraints considered behind the solution, etc.) in order the participants to reach enough mutual understanding about the way the solution has been produced, to be able to engage in a discussion. Thirdly, participants find effective to add annotations (symbolic) to the 3D CAD screenshots (iconic) during the review, which is clearer to understand than textual notes and enables them to backtrack important design information easier through the evolution of the CAD model.

3- Lessons for asynchronous computer-mediated design communication

The technical representation cases and the observed design case that we have presented in this article gives important ideas about how asynchronous argumentative design discourse can be supported with 3D design representations. We summarise these ideas as follows:

3.1- Importance of 3D CAD as iconic representation

Both the technical representations and the design case that we have presented show the important role of iconic representations when communication between several participants from different domains of expertise is concerned. 3D CAD successfully executes that role of boundary object (as described in [16, 17]) in our design case, in a sense that they provide the media to support the expression of shared knowledge between cross-domain actors and different functional interests between them, allowing these actors

negotiating around these objects, and facilitating the knowledge transformation.

3.2- Iconic vs. symbolic: two complementary dimensions

However, each of the cases shows that iconic representations must be complemented by symbolic expressions. The Encyclopaedia case shows, for instance, that non-geometric information has to be expressed by conventional representations (text in that case). In addition, the design case presented before points out that iconic design representations combined with conventional annotations is an effective way to express and share domain-specific design information. Symbolic representations can support iconic representations, by allowing design participants to express tacit information on representations, in order to increase their precision, as 2D case shows. They also can be means to express information that cannot be represented due to its non-geometrical nature.

3.2- Moving knowledge boundaries

Further, the design case shows that a 3D CAD representation is not sufficient in many design cases to allow participants to reach a mutual understanding of the design situation. The differences between points of view may constitute knowledge boundaries, in a way that the same representation may refer to different tacit knowledge and be interpreted differently by several participants. A communication tool should allow the participants to express their specific point of view by eliciting some domain specific information and place them on the representation, in order to overcome these knowledge boundaries. It is obviously a dynamic process which requires a constant attention, the needs evolving with the level of information shared by the group. When the participants have elicited a point, it is not necessary to recall it afterwards as the group has learnt on that point. But another point may show up and require attention, etc. This constant process of learning and eliciting is at a basic of design communication and must be supported by symbolic representations.

3.2- Conversation need

Another important need that arises in this analysis is that annotation model should support discussions. In order to deal with knowledge boundaries and advance through asynchronous co-operation around design representations, each design participant should be able to engage a discussion or a conversation with the other members. The process is recursive.

4- Conclusion

Co-operative design, as a social activity, requires strong interpersonal communication for mutual understanding and collective decision making. In concurrent engineering situations, where multiple participants from different domains of expertise need to communicate, successful communication requires adapted design artefacts to support communication between those participants.

In this paper, we have discussed how the mode of representation of a design artefact affects its capacity to adapt to a particular design situation. Our first conclusion is that iconic representations, where the product is represented by physical resemblance, offer a good media for communication between cross-domain participants. The non-conventional nature of these representations makes them remain interpretable to every design participant, which constitutes a common base for them, stimulating the communication.

However, this paper also shows that the common basis that iconic nature of 3D representations offers to designers must be supported by conventional symbolic representation systems, especially in asynchronous co-operation situations. As the cases we have discussed demonstrate, iconic representations can be interpreted in diverse ways by design actors from different domains, which can cause ambiguities and misunderstandings. However, symbolic representation systems, composed by conventions that are understood by all design participants who agreed on their meaning can offer rich and accurate design communication around 3D representations.

Thereby, we argue that more effort must be done in order to find conventions to support argumentative cross-domain design communication, and think about tools and models that offer effective utilisation of both iconic and symbolic representations, in a way to support their interpretation and reutilisation. That structure can be supported with manual or automatic meta-information, in order to capture accurately the communication context, and to extend the annotation's lifetime.

5- References

- [1] J. Wolfe, "Annotation technologies: A software and research review," *Computers and Composition*, vol. 19, pp. 471-497, 2002.
- [2] C. Baber, J. Cross, F. Yang, and P. Smith, "Supporting Shared Analysis for Mobile Investigators," presented at Proceedings of the International Workshop on Annotation for Collaboration - Methods, Tools and Practices, La Sorbonne Paris, France, 2005.
- [3] C. Marshall, M. N. Price, G. Golovchinsky, and B. N. Schilit, "Collaborating over portable reading appliances," *Personal Technologies*, pp. 43-53, 1999.
- [4] S. Guibert, F. Darses, and J.-F. Boujut, "Using annotations in engineering design: some results from an experimental study," presented at International Workshop on Annotation for Collaboration, Paris, 2005.
- [5] J.-F. Boujut, "User-defined annotations: artefacts for co-ordination and shared understanding in design teams," *J. Eng. Design*, vol. 14, pp. 409-419, 2003.
- [6] O. Hisarciklilar and J.-F. Boujut, "Reducing the "Information Gap" Between Synchronous and Asynchronous Co-operative Design Phases," presented at Virtual Concept '06, Cancun, Mexico, 2006.
- [7] V. Uren, P. Cimiano, J. Iria, S. Handschuh, M. Vargas-Vera, E. Motta, and F. Ciravegna, "Semantic annotation for knowledge management: requirements and a survey of the state of art," *web semantics: science, services and agents on the world wide web*, vol. 4, pp. 14-28, 2006.
- [8] J. Kahan and M.-R. Koivunen, "Annotea: an open {RDF} infrastructure for shared Web annotations," presented at Proceedings of the 10th International World Wide Web Conference, Hong Kong, 2001.
- [9] S. Handschuh and S. Staab, "Authoring and annotation of web pages in CREAM," presented at Proceedings of the 11th International World Wide Web Conference (WWW 2002), Honolulu, Hawaii, USA, 2002.
- [10] M. Zacklad, "Documentarisation Processes in Documents for Action (DofA): The Status of Annotations and Associated Cooperation Technologies," *Computer Supported Cooperative Work (CSCW)*, vol. 15, pp. 205-228, 2006.
- [11] C. Marshall, "Annotation: From paper books to the digital library," presented at ACM International Conference on Digital Libraries, Philadelphia, 1997.
- [12] C. S. Peirce, *Collected Writings*. Cambridge, MA: Harvard University Press, 1931-58.
- [13] O. Lavoisy, "La Matière et l'Action. Le graphisme technique comme instrument de la coordination industrielle dans le domaine de la mécanique depuis trois siècles," PhD thesis, ENSGI - INPG, Grenoble, 2000.
- [14] Diderot and d'Alembert, *L'Encyclopédie*. Paris: Inter-Livres, 1988.
- [15] P. Laureillard, "Conception intégrée dans l'usage: mise en oeuvre d'un dispositif d'intégration produit-process dans une filiale de conception de pièces forgées," PhD thesis, ENSGI - INPG, Grenoble, 2000.
- [16] P. R. Carlile, "A Pragmatic View of Knowledge and Boundaries: Boundary Objects in New Product Development," *Organization Science*, vol. 13, pp. 442-455, 2002.
- [17] S. L. Star, "The structure of ill-structured solutions: heterogenous problem solving, boundary objects and distributed artificial intelligence," in *Distributed artificial intelligence: vol 2*. San Fransisco, CA: Morgan Kaufmann Publishers Inc., 1990, pp. 37-54.