



HAL
open science

Evidence for a CO increase in the SH during the 20th century based on firn air samples from Berkner Island, Antarctica

S. S. Assonov, C. A. M. Brenninkmeijer, P. Jöckel, R. Mulvaney, Serge Bernard, J. Chappellaz

► To cite this version:

S. S. Assonov, C. A. M. Brenninkmeijer, P. Jöckel, R. Mulvaney, Serge Bernard, et al.. Evidence for a CO increase in the SH during the 20th century based on firn air samples from Berkner Island, Antarctica. *Atmospheric Chemistry and Physics*, 2007, 7 (2), pp.308. hal-00328478

HAL Id: hal-00328478

<https://hal.science/hal-00328478>

Submitted on 18 Jun 2008

HAL is a multi-disciplinary open access archive for the deposit and dissemination of scientific research documents, whether they are published or not. The documents may come from teaching and research institutions in France or abroad, or from public or private research centers.

L'archive ouverte pluridisciplinaire **HAL**, est destinée au dépôt et à la diffusion de documents scientifiques de niveau recherche, publiés ou non, émanant des établissements d'enseignement et de recherche français ou étrangers, des laboratoires publics ou privés.

Evidence for a CO increase in the SH during the 20th century based on firn air samples from Berkner Island, Antarctica

S. S. Assonov¹, C. A. M. Brenninkmeijer¹, P. Jöckel¹, R. Mulvaney², S. Bernard³, and J. Chappellaz³

¹Max Planck Institute for Chemistry, PO 3060, 55020 Mainz, Germany

²British Antarctic Survey, High Cross, Madingley Road, Cambridge CB3 0ET, UK

³Laboratoire de Glaciologie et Géophysique de l'Environnement, 54 rue Molière, Domaine Universitaire, BP 96, 38402 St. Martin d'Hères Cedex, France

Received: 3 August 2005 – Published in Atmos. Chem. Phys. Discuss.: 24 October 2005

Revised: 25 September 2006 – Accepted: 24 November 2006 – Published: 19 January 2007

Abstract. Trends of carbon monoxide (CO) for the past 100 years are reported as derived from Antarctic firn drilling expeditions. Only one of 3 campaigns provided high quality results. The trend was reconstructed using a firn air model in the forward mode to constrain age distributions and assuming the CO increase to be proportional to its major source, namely CH₄. The results suggest that CO has increased by ~38%, from 38±7 to 52.5±1.5 ppbv over a period of roughly 100 years. The concentrations are on the volumetric scale which corresponds to ~1.08 of the scale used by NOAA/CMDL. The estimated CO increase is somewhat larger than what is estimated from the CO budget estimations and the CH₄ growth alone. The most likely explanation might be an increase in biomass burning emissions. Using CH₃Cl as another proxy produces a very similar reconstruction.

1 Introduction

The reconstruction of past records for the atmospheric trace gases CO₂, CH₄ and N₂O is mainly based on the analysis of air extracted from firn (in the field) and ice cores (in the lab) from the Arctic and Antarctic. All three gases have been increasing rapidly over the previous century due mainly to human activity. Because the oxidation of CH₄ is a main source of CO, especially in the southern hemisphere, it can be expected that Southern Hemisphere (SH) CO also has been increasing.

However, little experimental information about past CO levels is available, and moreover, even recent data for the SH are rather scarce. The Cape Point (about 34° S) record is the longest (from 1978 to 1987, Brunke et al., 1990), but may be

influenced by biomass burning in Africa and South America. It shows an increase of ~0.29 ppbv/year. Khalil and Rasmussen (1988) also demonstrated some CO increase from 1981 to 1987 in Tasmania and Antarctic. The Cape Grim record from 1985 to 2004 (Baseline 2001–2002, page 46; also at http://www.dar.csiro.au/capegrim/image/cg_CO.png) appears to not demonstrate a clear trend in these years and shows in fact a peak in 1987, but long term calibration issues may still have to be resolved (Langenfelds, private communication, 2004). This record may differ from revised data of NOAA/CMDL (Novelli et al., 2003) showing practically a zero trend of CO in Antarctica from 1994 to 2004. Altogether one can state that the seasonal variations of CO in the remote SH are relatively well known, but that there is uncertainty about trends. Concerning the epoch preceding actual atmospheric measurements, Haan and Raynaud (1998) have reported that SH CO has increased between 250 BC and 1900 AD from about 50 to 57 ppbv. For these analyses the CO concentration in small amounts of air (~7 ml) extracted from Antarctic ice core samples had to be measured. These levels are rather high compared to the modern mean of 48.6 ppbv measured by NOAA/CMDL in Antarctica (data available at <http://www.cmdl.noaa.gov/info/ftpdata.html>). In contrast, a recent study by Ferretti et al. (2005) of Antarctic ice core samples covering 0 to 1700 AD demonstrated that CO in the SH decreased from ~70 ppbv around 1400s to ~50 ppbv in ~1700 AD, with the analytical uncertainty being 13.2 ppbv. As a reason for this, the authors proposed a decrease of biomass burning. We are not aware of other papers on past CO concentrations for the SH. The scarcity of data on CO may be due to its status as a non-greenhouse gas and because accurate and precise measurements of CO in the ppbv range have proven to be rather difficult, even in the present atmosphere. For instance, the harmonization of CO scales is still an ongoing issue (c.f. Brenninkmeijer et al., 2001; Novelli, 1999; Novelli et al., 1998a; Novelli et

Correspondence to: S. S. Assonov
(Sergey.ASSONOV@ec.europa.eu)

Table 1. Location and characteristics of the three firn sites.

Site	Location	Altitude	Precipitation ⁻¹ rate, cm H ₂ O*years	Annual mean temperature	Sampling dates
DML	77°02.39'S 10°30.08'W	2176 m	7	-39°C	January 1998
Dome C	75°06.1' S 123°23.7' E	3233 m	3	-54°C	Late December 1998 to early January 1999
Berkner	79°32.90' S 45°40.54' W	900 m	12	-26°C	January 2003

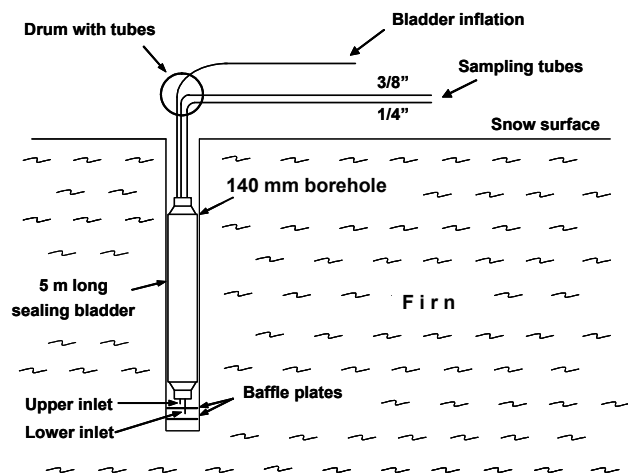
**Fig. 1.** Schematic of the firn air sampling system. The sections of the “Bender baffle” are 4.5 and 2.5 cm tall. Large air samples were collected from both the upper and lower sections.

al., 2003). Nonetheless, it is very interesting to understand past changes in CO because of its close link with CH₄ and in particular with OH, which is the troposphere’s major self-cleansing agent.

For several years we have partaken in Antarctic drilling campaigns and collected firn air samples with one of the objectives being to reconstruct past changes in CO. Besides aiming at the reconstruction of past CO trends, one of our objectives was to measure ¹⁴CO. This ultra trace gas (about 10 molecules per cm³ of air) is an ideal tracer for detecting changes in the OH concentration (Volz et al., 1981; Breninkmeijer et al., 1993; Manning et al., 2005). This application requires large samples of air (several hundred liters of air), because about 1 million ¹⁴CO molecules have to be collected to obtain a precision of 1% (e.g. Volz et al., 1981).

Unfortunately, we are not able to report much on ¹⁴CO, because its concentration appears to increase with sample depth due to the release of in situ produced ¹⁴CO from the ice matrix into the firn air (e.g. Assonov et al., 2005). As this release was found at the 3 firn sites with very different char-

acteristics (temperature, elevation and annual accumulation rate), neither firn air nor air enclosed in ice bubbles can be used for the ¹⁴CO application.

Another advantage of large samples is that the stable isotopic composition of CO can be assayed. Nowadays continuous flow IRMS has obviated the need for having large amounts of air available, but at the beginning of our firn air sampling, large samples were required for IRMS analysis. Although currently we use isotope data mostly to assure the data quality, in future stable isotope analyses will help to reconstruct and understand past changes in CO.

Only one of our 3 firn sampling campaigns has been successful in terms of CO data quality, and only 8 depth levels under analyses have recorded a long-term CO trend. However, because all the measurements have been performed on the same instrument and are on the same scale (thus avoiding problems of long-term calibration stability and scale compatibility) and because of a low overall blank, the data obtained clearly demonstrate a CO decrease with depth, which implies a record of lower CO in the past. We propose a simple reconstruction which considers the year-to-year changes of CO being proportional to changes of its precursors, namely CH₄ and biomass burning as represented by CH₃Cl. Though several potential error sources of the reconstruction exist and though we might have missed some fine details of CO trends and though making a comprehensive error balance is not possible, the general trend of CO in SH appears to be caught for the first time. More detailed reconstructions will require a combination of data from several firn sites having different characteristics such as annual accumulation rate, temperature, presence of melting layers (which confine vertical air movement) and, most important, narrow gas age distributions. As research on past levels of CO will continue, we describe here not only our results, but also the problems encountered.

2 Experimental, sampling procedure and site description

Firn air samples were taken at three sites: Dronning Maud Land, Dome Concordia and Berkner Island (see Table 1, abbreviated DML, Dome C, and Berkner respectively) during 3 expeditions within the framework of FIRETRACC (Firn

REcord of Trace gases Relevant to Atmospheric Chemical Change) and CRYOSTAT (CRYOspheric STudies of Atmospheric Trends in stratospherically and radiatively important gases). Details of the firn drilling, air sampling, and site descriptions are given in (Bräunlich et al., 2001; Mulvaney et al., 2002; Sturges et al., 2001a; Sturges et al., 2001b).

The basics of the firn air collection are depicted in Fig. 1. After drilling to a certain depth, the sampling device was lowered into the bore hole, leaving a “headspace” at the bottom for withdrawing firn air. The inflatable bladder was pressurized to seal the borehole, after which air was withdrawn both through the upper inlet in the “Bender baffle” (via a 3/8 inch flushing line) and through the lower inlet (via an 1/4 inch sampling line). The air was directed to waste until the CO₂ concentration (measured in situ using a LICOR instrument) stabilised at a low level indicating effective removal of contamination by younger and/or ambient air. At this moment sampling started.

Two sample types were taken – small samples (several-liter volumes filled at several bar pressure, as typically collected from firn) and large samples which were used for CO analyses. For small samples, sampled air (tens of liters) was taken from the lower inlet while air continuously withdrawn through the upper inlet (Fig. 1) was directed to waste. The reason for this is to eliminate air that may be contaminated by out-gassing of the rubber bladder material. For taking large samples (500 l and some samples of 1000 l) substantially larger amounts of air were withdrawn, and the two lines were shunted in parallel to minimize pumping resistance. The pumping system used for large samples consists of a 2-stage metal bellows pump which feeds air into a modified Rix compressor (Mak and Brenninkmeijer, 1994). The pumping rate and thus filling time depends on the resistance at the drilling depth. As far as possible the pressure between the pump and compressor was kept above ambient, because the Rix compressors are not entirely leak tight against entraining ambient air. The large samples were dried using Drierite (basically CaSO₄) at a pressure of over 40 bar. After sampling at a given depth, the sampling device was raised after which drilling to the next level took place.

As sampling disturbs the existing firn air stratification in the vicinity of the sampling horizon, large samples may represent larger depth intervals than small samples taken at the same depth (Bräunlich et al., 2001). This sampling effect being specific for large samples results in a certain error to firn air reconstructions. No specific data or calculations as to the actual depth interval sampled, or the 3-D shape of the catchment volume are available.

For the three sites the firn diffusivity profiles were calibrated by using CO₂ data obtained on small samples. (This work was performed by the LGGE team). The data of large samples were not used for this calibration – firstly because the small samples provide a higher depth-coverage and secondly because of a possible depth-bias of the large samples,

which may affect the concentrations of different trace gases differently.

The general advantage of large samples is that they are less affected by CO production in the sampling cylinders than small samples. However, an additional potential source of contamination is CO production in the high pressure compressor. During the first campaign at DML, warming of the compressor was not controlled. At Dome C, due to low ambient pressure (an elevated site, see Table 1) it was difficult to fill cylinders near COD (Close-Off-Depth), and the compressor did warm up and was run for a prolonged time, thus unfavourably increasing contamination. This explains high CO measured at Dome C near COD (Fig. 2). At Berkner, close attention was paid to avoid compressor overloading. Moreover, two zero-air samples (ambient air passed through a CO destroying catalyst) were taken, one before and one after the firn drilling by using the same equipment and the same tubing. By this way a low value of the overall blank (including production in sampling cylinders) could be confirmed. Because zero-air samples have demonstrated low CO, all samples from the shallow and mid depths, where the pumping is similar to that for the zero tests, should be free of contamination. The second potential source of contamination is leakage in the high pressure compressor and/or between borehole and bladder walls. When the pressure at the inlet of the 3-stage Rix high-pressure compressor is below ambient, the first stage of this compressor is prone to entrain ambient air. This may have affected the deepest samples taken at 57.89 to 58.88 m, as the inlet pressure of the first metal bellows compressor decreased from ~ -0.4 bar for most samples to ~ -0.5 bar (Fig. 3), which reflects the increase in firn resistance to air movement. To quantify the degree of leakage, SF₆ was used as tracer having a zero concentration in old firn air. Indeed, the slightly enhanced SF₆ concentration in the 58.88 m sample as compared to the 56.96 m sample (Fig. 4) indicates some contamination by ambient air of the order of 15%.

The trace gas separation was described in (Bräunlich et al., 2001; Brenninkmeijer, 1993; Brenninkmeijer et al., 2001). Briefly, after removing CO₂ to sub ppbv levels, CO is oxidized to CO₂ followed by its cryogenic collection. The oxidising reagent preserves the original oxygen atom of CO so that $\delta^{18}\text{O}(\text{CO})$ is obtained after an appropriate correction. After removing traces of H₂O, the amount of CO-derived CO₂ is determined volumetrically (Brenninkmeijer et al., 2001). This method is free from problems related to long-term stability of CO in high pressure cylinders (Novelli et al., 1998b; Novelli et al., 2003). This also implies that our CO scale may differ from that of NOAA/CMDL (see below). A Finnigan MAT 252 Isotope Ratio Mass Spectrometer (Bremen, Germany) was used to determine $\delta^{13}\text{C}(\text{CO})$ and $\delta^{18}\text{O}(\text{CO})$. Most samples from Dome C and DML and 3 samples from Berkner have been analysed for ¹⁴C (data plotted in Assonov et al., 2005). The two zero-air samples taken at Berkner yielded CO mixing ratios of 1.1 and 1.6 ppbv. These provide an estimate of the complete

Table 2. CO mixing ratio and isotope ratios of firn air samples from Berkner Island. (All values are blank corrected.)

Firn depth, m	Date, [dd/mm/yy]	CO ppbv, blank corrected*	$\delta^{13}\text{C}(\text{CO})^*$, ‰ VPDB	$\delta^{18}\text{O}(\text{CO})^*$ ‰
0.00	10 Jan 03	46.4±1.3	-28.2±0.5	-6.7
0.00	29 Jan 03	39.5±1.3	n.a.	n.a.
6.05	12 Jan 03	55.0±1.3	-28.1±0.5	-8.0
9.85	13 Jan 03	55.8±1.3	-27.9±0.5	-5.3
19.94	14 Jan 03	53.2±1.3	-28.7±0.5	-4.3
39.68	15 Jan 03	48.5±1.3	-28.2±0.5	-4.7
45.01	16 Jan 03	48.8±1.3	-28.1±0.5	-4.6
47.93	16 Jan 03	51.6±1.3	n.a.	n.a.
49.99	17 Jan 03	49.5±1.3	-28.2±0.5	-5.4
52.13	17 Jan 03	51.6±1.3	n.a.	n.a.
52.99	18 Jan 03	50.4±1.3	n.a.	n.a.
53.95	18 Jan 03	50.5±1.3	n.a.	n.a.
54.93	18 Jan 03	47.3±1.3	-27.5±0.5	-4.7
55.95	18 Jan 03	49.2±1.3	n.a.	n.a.
56.96	20 Jan 03	48.6±1.3	-27.0±0.5	n.a.
57.89	20 Jan 03	45.9±1.3	n.a.	n.a.
58.88	21 Jan 03	45.7±1.6**	n.a.	n.a.
58.88, duplicate sample	21 Jan 03	45.1±1.6**	-27.0±0.7	-4.5
58.88 m, duplicate sample, second analysis	21 Jan 03	45.5±1.6**	n.a.	n.a.

* – values are blank-corrected with $[\text{CO}] = 1.33 \pm 0.66$ ppbv and $\delta^{13}\text{C}(\text{CO}) = -50 \pm 15$ ‰. $\delta^{13}\text{C}(\text{CO})$ values have been corrected for gravitation as well as for differences in ^{13}C and ^{12}C diffusion in firn and for the CO increase. The errors represent 2- σ values. ** – values are corrected for $15 \pm 7.5\%$ contamination with ambient air. For this purpose, the lower value of 39.5 ppbv measured in the ambient air was used.

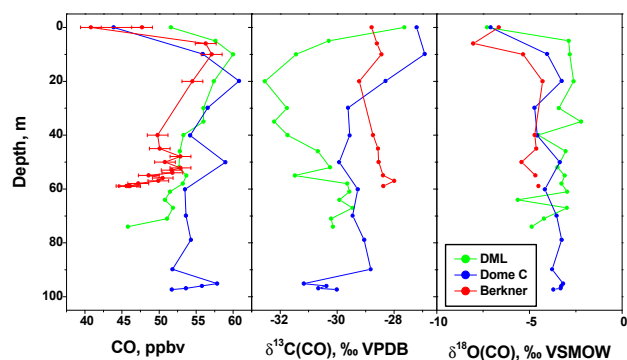

Fig. 2. CO mixing and isotope ratios measured at three sites in Antarctica. The data plotted are not blank corrected. The blanks measured at Berkner had low CO mixing ratios; at two other sites blanks were not measured.

blanks arising from the tubing, compressors and storage in the cylinders until the date of sample processing. Because the CO blanks were extremely small, $\delta^{13}\text{C}(\text{CO})$ could not be measured. From previous experiments it is known, however, that contamination from compressors shifts $\delta^{13}\text{C}(\text{CO})$ in the negative direction. Values of $[\text{CO}] = 1.33 \pm 0.66$ ppbv and $\delta^{13}\text{C}(\text{CO}) = -50 \pm 15$ ‰ (VPDB- CO_2) were used for the blank-correction applied to the Berkner samples. Data obtained at DML and Dome C could not be blank-corrected and are not used for our calculations.

In anticipation that $\Delta^{17}\text{O}$ analysis on small samples will be developed in the future, e.g., by CF-IRMS, some of the extracted CO has been archived. For these samples only the CO content was determined, without determinations for ^{13}C and ^{18}O .

3 Results

3.1 CO data

The CO values measured in firn air at DML and Dome C are higher than those of Berkner and both $\delta^{13}\text{C}$ and $\delta^{18}\text{O}$ show a more irregular pattern (Fig. 2). Such differences, remote from surface sources of CO, are not likely to be real, and by virtue of the zero-air tests carried out at Berkner, it is concluded that only these values reflect real atmospheric values. The two Berkner samples at 58.88 mm have 15% contamination by ambient air (see above). The samples from 58.88 m were taken on 21 January 2003 when CO decreases rapidly. At Berkner on 10 January 2003 CO was 46.4 ppbv, and on 29 January CO was 39.5 ppbv (before and after drilling). Considering the lowest CO in the ambient air to be 39.5 ppbv (the worst case) a possible negative bias is evaluated of up to 0.9 ppbv. The estimated true values at 58.88 m (Table 2) are obtained by correcting the measured values for this bias, assuming an uncertainty of 50% for the contamination.

The amplitude of the CO seasonal cycle in Antarctica is 27% of the annual mean (data by NOAA/CMDL, Fig. 6). As

seasonal cycle variations at Berkner are attenuated at depths below 40 m (Fig. 7), signals below that depths record the long-term trend. Below 53.95 m depth, CO signals measured at Berkner show a consistent decrease (Fig. 2) which evidences lower CO in the past. From 47.93 to 53.95 m, CO signals show some scatter, without any clear trend (Table 2). In the first instance, this range of depths may be used to evaluate an actual determination error. The signal averaged from 47.93 to 53.95 m is 50.7 ± 1.2 ppbv (blank-corrected values, 95% level). Values measured at 39.68 and 45.01 m show a negative excursion from this mean which in fact may indicate a relative decrease in the recent year(s), being similar or maybe even more pronounced than that recorded at NOAA/CMDL stations in the year 2002 (Fig. 6). However the CO reconstructions presented in this work appear to fail in explaining these two samples, see below.

3.2 Different approaches used to reconstruct firn air data

The interpretation of firn air records is never free from a range of assumptions. A very simplified approach is to consider a relationship between concentrations measured in firn and mean ages of gas for each depth. That approach ignores the fact that gas at any depth is a mixture of portions of different ages. A similar, compromised approach is to link a gas profile in firn to that for a gas with known atmospheric trend (e.g. CFC-12) by using the diffusivity ratio for two gases (e.g. Sturges et al., 2001a, 2001b).

A 1-dimensional model is often used to simulate gas phase diffusion and gravitational separation of gases in firn, based on specified depth profiles of firn (e.g. Rommelaere et al., 1997). One method adopted to reconstruct unknown atmospheric trends based on firn data is to run hundreds of random scenarios by using a firn model in forward mode and then select scenarios producing the best match (the Monte Carlo method, e.g. Bräunlich et al., 2001; Röckmann et al., 2003; Sowers et al., 2005). This is a good approach where neither trend direction nor any other information is reliably known a priori. However, that approach can in principle produce some solutions giving unrealistic fluctuations.

A Bayesian synthesis inversion was developed by Trudinger et al. (2002). This approach uses an a priori estimate of atmospheric trends by taking mixing ratios measured in firn and assigning them means of model age distribution. Next, the optimization is carried out via an inversion synthesis by minimizing the sum of differences between model-generated values and observations as well as a difference from an a priori estimate. Model-generated age distributions are considered as unique information required for reconstructing the atmospheric trend. The Trudinger algorithm works well when a substantial age range is covered by the samples and, most importantly, the age distributions are narrow and do not overlap each other (see Fig. 2 in Trudinger et al., 2002, 2004).

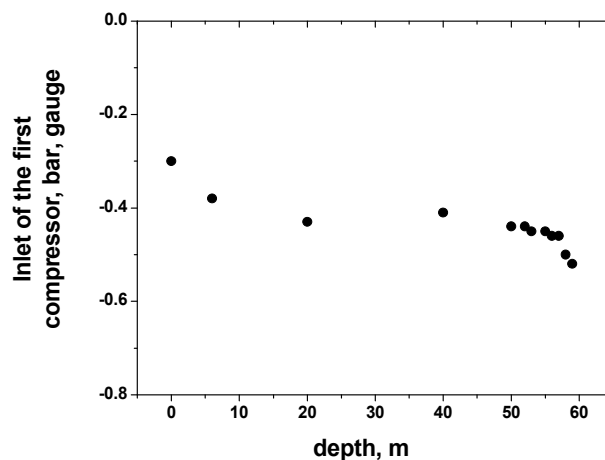

Fig. 3. Inlet pressure of the first compressor (metal bellows pump) during sampling.

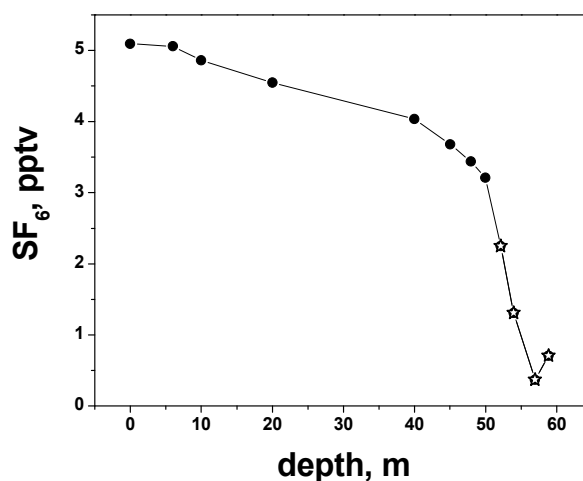

Fig. 4. Profile of SF₆ at Berkner measured by MPI-Chemistry, Mainz (circles) and by University of Heidelberg (stars). The increase near COD indicates contamination by ambient air, most likely due to compressor leakage. Error bars are smaller than the symbol size.

As the age distributions at Berkner are broad (see below and Fig. 5), we cannot use this approach. The bottom line is that because the age distributions at Berkner cover ~ 100 years (Fig. 5) and because CO decreases with depth (Fig. 2), one must conclude that CO was lower in the past. Because of the 45.4 ± 1.6 ppbv in the year 1968 (the age distribution mean) measured for the sample 58.88 m vs. 50.7 ± 1.2 ppbv found for the mid-depths (see Sect. 3.1) which may be considered as a first estimate for the modern mean, CO has increased by at least 12% since 1968. The question is how to reconstruct the CO trend based on the data

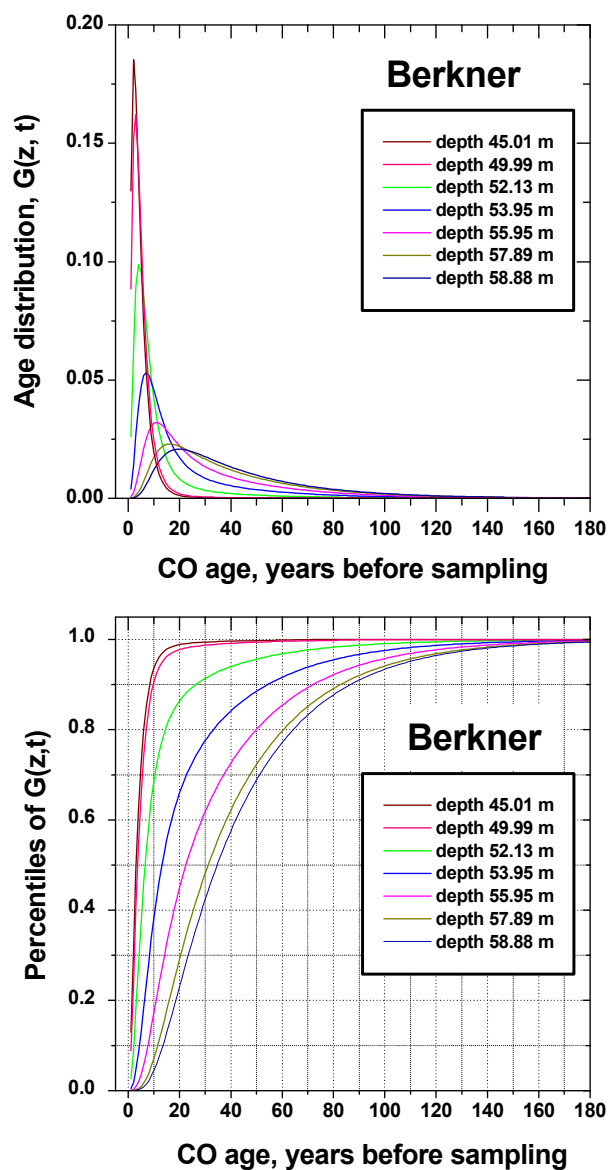

Fig. 5. CO age distributions modelled for several depths at Berkner (upper panel), and distribution percentiles (lower panel). For illustration, sets of discrete values $G(z,t)$ obtained for each depth are presented by a line.

available. Berkner samples contain information of years preceding 1968, e.g. the sample 58.88 m has 12% of CO being older than 1920 (Fig. 5). Therefore, we used a combination of model generated age distributions and introduced a constraint for the shape of CO increase (see Sect. 3.4).

3.3 Firn model and age distributions

The firn air diffusion model (Rommelaere et al., 1997) was applied in the forward mode. The depth diffusivity profile

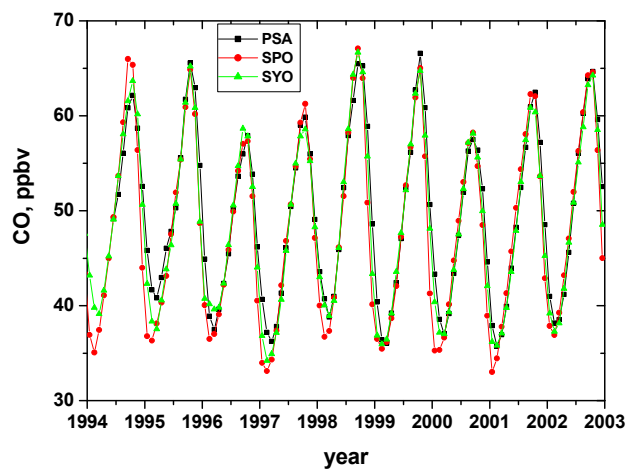

Fig. 6. CO observations by NOAA/CMDL at the Antarctic stations Palmer (PSA), South Pole (SPO) and Syowa (SYO). Data are taken from the NOAA/CMDL archive at <http://www.cmdl.noaa.gov/info/ftpdata.html> (downloaded on 5 July 2004). The year number denotes 1st January.

was calibrated by the LGGE team as described in (Fabre et al., 2000), namely to get the best agreement between model-generated CO_2 values (using the known atmospheric CO_2 trend as model input) and the CO_2 signals measured in firn air samples. For this purpose, the small samples taken from the lower section in the baffle (see above) were used. Testing the model for Dome C and DML demonstrated a good agreement between the measured signals and the model-generated $^{14}\text{CO}_2$, $\delta^{13}\text{C}(\text{CO}_2)$ and CO_2 mixing ratios (Assonov et al., 2005). For Berkner the test was done by comparison of measured and modelled CH_4 signals (Assonov et al., 2005). Based on that test it was argued that the actual sampling depth at Berkner might have been biased upwards relative to the nominal drilling depth, in agreement with the findings by Bräunlich et al. (2001) for DML and Dome C. In fact, this test is very sensitive to the input scenario and actual depth bias may differ from one gas compound to another. As we were not able to better constrain a possible depth bias and/or a spatial distribution of the sampled air, we used the nominal depths for the modelling purpose.

The model was used to generate age distributions (Fig. 5) being the response function $G(z,t)$ of an input atmospheric signal $a(t)$ for the depth z . This was done by taking a time step of 1 year and assuming zero increase in atmospheric CO, thus ignoring possible fluctuations in the real atmospheric CO trend. That is the standard approach for constructing age distributions (c.f., Bräunlich et al., 2001; Kaspers et al., 2004; Trudinger et al., 2002; Trudinger et al., 2004). The distribution for a given depth z represents the relative contribution of different ages, so that $\sum G(z,t) \equiv 1$. (Notably, age distributions for different trace gases are different.) For depths less than 52.13 m the distributions have non-zero val-

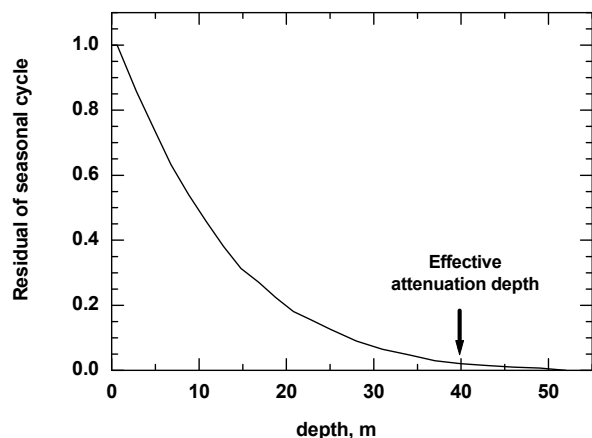

Fig. 7. Modelled attenuation of the CO seasonal cycle with depth at Berkner. At depths below 40 m, the residuals are smaller than $1/2\sigma$.

ues for the first year (Fig. 5) indicating that the weight of ages <1 year cannot be determined explicitly. Using a time step <1 year would make no improvement because it would require accurate information on the seasonal variation of CO at the sampling site for the year before sampling, which is not available. Therefore, only the distributions obtained for depths 52.13 m and below are used in the reconstructions.

3.4 Reconstruction of the CO trend

A detailed discussion on a reconstruction of atmospheric trends from firn air data by using age distributions was presented by Trudinger et al. (2002). Because a trace gas at any given depth z is a mixture of gas proportions of different ages, the gas concentration may be presented (see Eq. 4 in Trudinger et al. 2002) as follows:

$$CO(z) = \sum_{t=\min}^N [G(z, t) * CO(t)] \quad (1)$$

where $CO(z)$ is the model-predicted concentration at the depth z , $G(z, t)$ is the age distribution at the depth z and $CO(t)$ is a concentration trend in the atmosphere. The value N corresponds to $G(z, N) \rightarrow 0$, which is 200 years for Berkner (Fig. 5), the value $t=\min$ corresponds to the time step used to construct $G(z, t)$, that is 1 year in the present case.

A $CO(t)$ scenario to be tested is constructed as follows. Because CO is a short-lived compound whose major sources in the SH are CH_4 oxidation, biomass burning and NMHC oxidation, we introduce a link between a year-to-year change in CO and that in CH_4 or biomass burning (the latter presented as CH_3Cl) as following:

$$[CO(t) - CO(t-1)] = k_1 * [CH_4(t) - CH_4(t-1)] \quad (2)$$

Before 1994, when no CO measurements in Antarctica were performed, $CO(t)$ is taken to be related to the known trend

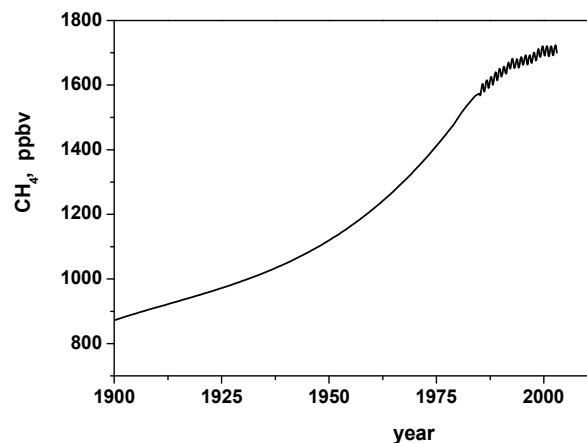

Fig. 8. Reconstruction of the atmospheric CH_4 trend using the Law Dome firn/ice core data (Etheridge et al., 1998) combined with NOAA/CMDL observations at three Antarctic stations starting in 1983 (South Pole, Halley, Palmer and Syowa, monthly means downloaded from <http://www.cmdl.noaa.gov/info/ftpdata.html> on 5 July 2004.)

of CH_4 (or CH_3Cl) by Eq. (2) in which the coefficient k_1 is taken as a variable. The CH_4 trend is based on the ice cores/firn data (Etheridge et al., 1998) combined with direct CH_4 observations in Antarctica by NOAA/CMDL starting in 1983 (South Pole, Halley, Palmer and Syowa, <http://www.cmdl.noaa.gov/info/ftpdata.html>, see Fig. 6). Prior to 1900 the CH_4 trend is assumed to be zero. The CH_3Cl trend is based on the detailed reconstruction given by Trudinger et al. (2004) assuming its trend to be zero before 1920. Equation (2) implies the continuity of the atmospheric CO trend. Atmospheric CO observed from 1994 to 2002 by NOAA/CMDL in Antarctica (Fig. 6) are introduced in the scenario by averaging data over 3 stations. The NOAA/CMDL data are introduced with a scaling coefficient k_2 which accounts for differences of our CO scale relative to the CO scale of NOAA/CMDL. The scaling coefficient is taken as a variable because of uncertainties in the current scale factor between two laboratories, in particular for low mixing ratios (see Sect. 5.1). The year 1993 where the CH_4 - or CH_3Cl -based part and the observation-based part (years 1994–2002) are connected should represent the long-term CH_4 -CO relationship in general. From 1994 to 2002 the CO trend in Antarctic appears to be zero (Novelli et al., 2003) and fluctuations observed may be assumed to be due to annual variability of CO sources, the mean of the NOAA/CMDL data from 1994 to 2002 (Fig. 6) is taken for the year 1993.

Then, to constrain an atmospheric trend $a(t)$ for a gas with unknown history Trudinger et al. (2002) have minimised the objective function, namely a sum of differences between measured and modelled concentrations (a scenario) and a

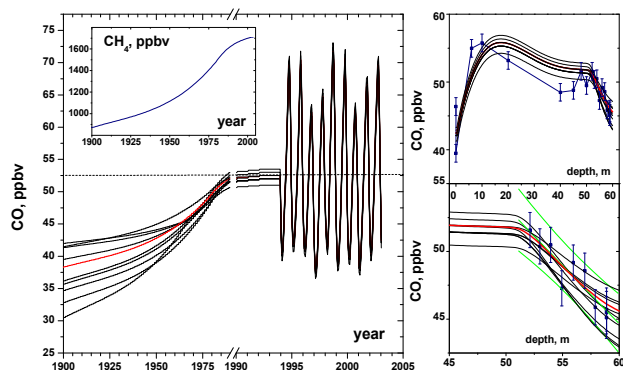

Fig. 9. Family of CO reconstructions based on modelled CO age distributions and the CH₄ year-to-year increase. The most plausible reconstruction is shown in red, other lines illustrate the uncertainty envelope. The two right panels compare the reconstructions with the observations. To visualise CO observations for the depth range from 52.13 to 58.88 m, the linear fit as well as its 95% confidence intervals are plotted (green lines, the right lower panel).

deviation from the prior estimate (a least-squares method). In the present work the objective function is introduced as follows:

$$\Psi = \sum_{z=\min}^{z=\max} \left[\left(CO(z) - \sum_{t=1}^N (G(z, t) * CO(t)) \right) / u_z \right]^2 \quad (3)$$

where u_z represents the errors of the firn measurements, $z=\min$ corresponds to a depth where the weight of young gas is approaching zero (for Berkner -52.13 m and deeper) and $z=\max$ is the maximum depth covered by the measurements.

By minimising Ψ in Eq. (3), the atmospheric scenario $CO(t)$ may be optimized and in this way the CO atmospheric trend may be constrained. The optimisation was performed by changing the coefficient k_1 in Eq. (2) and the coefficient k_2 (the factor between the CO scale of NOAA/CMDL and our volumetric scale, see below). In this way, a family of atmospheric CO trends is obtained which satisfy the criteria of Ψ (Eq. 3) being minimal.

The best fit based on the CH₄ trend is obtained for an average CO mixing ratio of 52.5 ppbv ($k_2=1.08$) for the period 1994 to 2002 and 38 ppbv for the early 1900s (Fig. 9). The coefficient k_1 corresponds to the CH₄-related CO source being $\sim 55\%$ for the present day CO budget. This value is higher than $\sim 40\%$ inferred for the modern CO at South Pole by using inverse model (Bergamaschi et al., 2000). Thus, the CH₄ increase alone cannot explain the observed increase of CO, implying that CO sources other than CH₄ oxidation must also have increased during the 20 th century, with biomass burning being the most likely candidate.

To explore error envelopes of the reconstructed trend, a family of trends was obtained based on the best scenario. First, the coefficients k_1 and k_2 were varied such that the

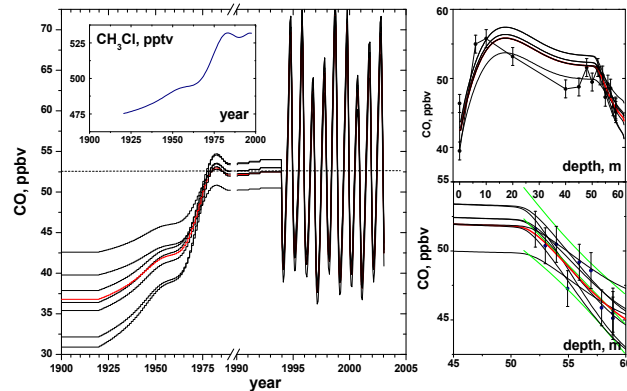

Fig. 10. Family of CO reconstructions based on modeled CO age distributions and the CH₃Cl year-to-year increase (data from Trudinger et al., 2004). This figure is constructed in the same way as Fig. 9.

value for the mean for the period 1994 to 2002 varied from 50.5 to 54 ppbv. In addition, the coefficient k_1 was varied before the year 1968. The year 1968 was selected because this is the mean age of the deepest sample and reconstruction beyond this point is presumed to have a larger uncertainty. To investigate the validity of the reconstructed CO trends, they were used as input for the firn diffusion model. All the constructed trends, when used as input for the firn model, produce model-generated CO concentrations within the 95% confidence intervals of observations (Fig. 9). The result is an envelope with mixing ratios of 38 ± 7 ppbv for the early 1900s and 52.5 ± 1.5 ppbv for the period from 1994 to 2002. The family of CO reconstructions related to CH₃Cl (Fig. 10) is in fact very similar to the family based on the CH₄ trend (Fig. 9), both in terms of the mean for 1994 to 2002 (52.5 ppbv) and the most likely CO levels for the early 1900s (37 ppbv) (Fig. 11). It is noted that both reconstructions fail to explain the negative excursion of measured CO values at 45.01 and 47.93 m (Fig. 9 and Fig. 10). That deviation may in fact reflect a low value of CO in the year(s) preceding sampling or reflect an unrecognized problem.

4 Discussion

4.1 Error sources and error analysis

Three major factors contributing to the uncertainty of reconstructions based on firn air samples are listed by Trudinger et al. (2004) as follows:

- Uncertainty due to smoothing of atmospheric signals in firn and loss of information caused by diffusion process in firn;
- Analytical, sampling and calibration uncertainties;

- Uncertainties related to the model, including uncertainties of model calibration, of diffusion coefficients etc.

We expand this list further as following:

- Uncertainty arising from the seasonality of CO;
- A possible depth bias as well as a 3-D effect due to taking large samples;
- CO chemical alteration/production in firn;
- Uncertainty of the approach based on a proxy, in the form of CH₄- and CH₃Cl-trends.

Let us briefly discuss these factors.

- Air diffusion in firn is known to smooth signals and reconstructions based on firn data cannot depict the fine structure of atmospheric gas histories. Only a general trend may be reconstructed. The width of age distributions serves as an indicator of signal smoothing in firn and is in fact a quality indicator for a certain firn site. The broader the distributions are, the larger is the smoothing and the lower the detail of atmospheric trend which may be reconstructed.
- Analytical uncertainty and the calibration of CO scales have been considered extensively. The use of data presented in the form of the fit line with 95 % intervals (Fig. 9 and 10) incorporates the analytical uncertainty into the reconstructions. Inter-laboratory scale consistency is explored by varying the modern mean CO (mean from 1994 to 2002) from 51.0 to 54.0 ppbv. The best fit is found at 52.5 ± 1.5 ppbv (with $k_2=1.08$). As discussed below, this factor is consistent with recent laboratory intercomparisons.
- Uncertainties related to the firn model have not been explored. In this respect we note that several models developed by different groups (e.g. Schwander, 1989; Rommelaere et al., 1997; Trudinger et al., 2002) differ in codes, their approach on how to calibrate firn depth profiles, and how to make pressure and temperature corrections etc. Firn is a complex medium whose parameters (accumulation rate, porosity, density, melt layers, tortuosity, depth of a well-ventilated layer) may have changed from year-to-year and even have seasonal fluctuations (e.g. Weiler et al., 2005). Seasonal temperature fluctuations in the upper few meters (Severinghaus et al., 2001) also play a role. All these effects are still not implemented in models, yet appear to be particularly important for the reconstruction of CO which has large seasonal variations (Fig. 6). The uncertainties from these effects presumably exceed the uncertainties related to the model in use and its calibration.

- CO in Antarctica has a large seasonality (Fig. 6), and two related aspects are of particular importance for reconstructions based on firn air samples. First, in order to use data from all the depths analysed, CO concentrations at the sampling site in the year preceding sampling, and especially in a few days/weeks before sampling, must be known in detail and introduced in the model input. Second, the model should be run with a short time step, maybe of a few days, and be adapted to the exact dates of sampling from different levels. Because we do not have detailed CO time series at Berkner, only depths recording long-term trends (that is below 52.13 m) may be used. This also justifies the use of the age distributions constructed with 1 year time step. Another error which we cannot evaluate comes from the fact that CO measured at 3 Antarctic sites by NOAA (Fig. 6) differ for 1 to 3 ppb and the average taken may still inaccurately describe CO seasonal cycle at Berkner.
- A possible depth bias as well as the 3-D effect of large samples have neither been evaluated nor modelled. Because of the strong gradient/decrease of open porosity with depth, the sampled area must be asymmetrically biased towards shallower depths vs. the nominal depth. This tendency was confirmed by CH₄ measurements on normal size and large firn air samples (Bräunlich et al., 2001). As these would shift the reconstructed age distributions to younger age, our reconstruction can be considered as a lower limit for the CO increase.
- Aspects of CO production in firn and the approach based on a proxy are discussed in 4.2.

Taken together, CO reconstruction has several error sources that are difficult to quantify. Currently we are not able to evaluate all the errors explicitly and this is a shortcoming of the present work. Similar problems are noted in other papers dealing with firn air reconstructions (e.g. Bräunlich et al., 2001; Röckmann et al., 2003; Sturges et al., 2001a; Kaspers et al., 2004; Sowers et al., 2005) where only some of the possible error sources are discussed. It was recognized before (Butler et al., 1999) that reliable and robust reconstructions require data from several firn sites with different parameters (diffusion profiles, temperature and accumulation rates etc.) and hence different smoothing effects. This is particularly true for CO because of its large seasonality and the possible CO production in firn.

4.2 Use of a proxy for CO trend – a solution or problem?

The approach used in this work is to a certain degree a combination of the approaches listed in Sect. 3.2. On the one hand, age distributions and the objective function are used in the same way as used by Trudinger et al. (2002). On the other hand, final tests of a proxy-based optimized scenario

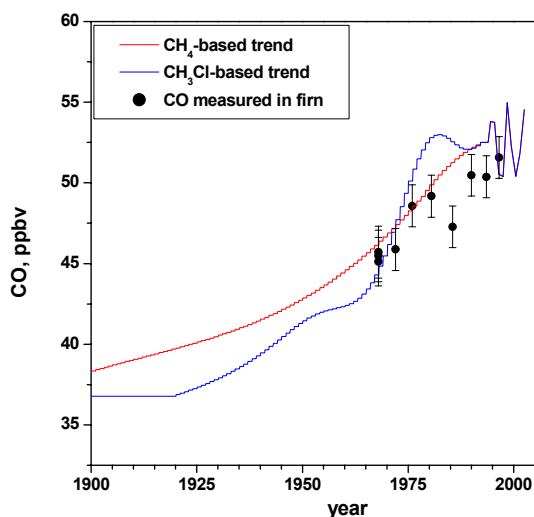

Fig. 11. CO reconstructions based on CH_4 and CH_3Cl trends and measured CO values plotted vs. respective means of model age distributions. Only annual means are presented, without showing the CO seasonal cycle.

is done in the way used both for the Monte Carlo and for the Trudinger method – i.e. when used as a model input, the model-generated profile should match the observations.

In contrast to running a large number of random scenarios, including possibly non-realistic ones (the Monte Carlo method), the use of a proxy linked to CO sources is the most practical choice – it assumes that changes of CO in the past have been proportional to the changes of other trace gases that constitute or reflect main sources of atmospheric CO and do have known trends, namely CH_4 and CH_3Cl . These two gases have both natural sources and sources related to biomass burning and anthropogenic activity. There are clear reasons to use the past CH_4 trend as a proxy for CO:

1. oxidation of CH_4 is an important source of SH CO, contributing to about 40 % in SH high latitudes (Bergamaschi et al., 2000);
2. the atmospheric CH_4 trend is well known and methane nearly doubled during the 20th century (e.g. data from Etheridge et al., 1998; Ferretti et al., 2005);
3. Industrial/anthropogenic CO sources in the SH are negligible and transport from the NH is strongly limited due to the short life-time of CO (c.f. Manning et al., 1997).

CH_4 , OH and CO form a complex system in the atmosphere. Obviously, assuming the CO level being proportional to that of CH_4 is a simplification and possible OH and/or CH_4 variations would indirectly affect this proportionality. The effect of variations in CH_4 and/or in OH must be considered first. It has been discussed and proven by using a simple model that the increase of CO in the NH in 1997–1998 (due

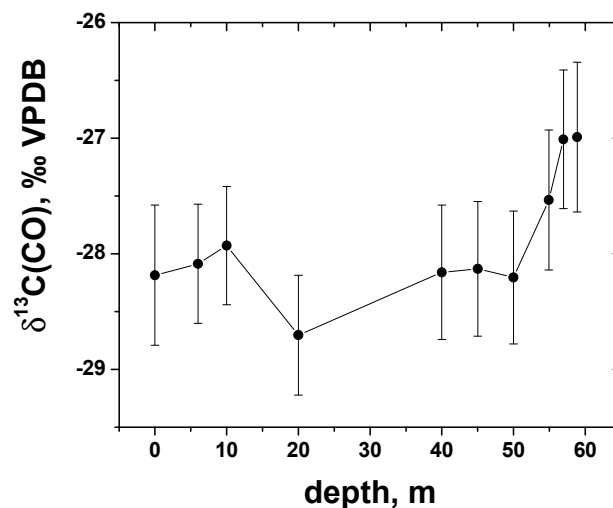

Fig. 12. Vertical profile of the $\delta^{13}\text{C}(\text{CO})$ values corrected for the blank and the gravitation effect. The error bars represent 2- σ values.

to biomass burning) resulted in a decrease of OH and thus in a decrease of CH_4 removal (Butler et al., 2005). The opposite must be true also. Should CH_4 be the only source of CO, the ratio of CH_4 to CO in equilibrium would depend only a little on OH, because it contributes both to CH_4 oxidation and CO destruction. Insofar as the increased CH_4 burden would lead to reduced OH, this on its own would cause an additional increase of CO, simply because CO from other sources (e.g. biomass burning) would also be destroyed slower. Although the equilibrium CO/ CH_4 ratio would not change much, the rate of CO removal (as well as CO formed by other sources, e.g. VOC oxidation) would be reduced. Although changes in OH can have occurred, and may be occurring, and in this way to some degree decouple changes in CO from those in CH_4 , the CH_4 -related source of CO in the past CO budget might be somewhat larger than that we evaluated based on the CH_4 increase and the present day CO budget. That may partly explain why the proportionality factor found in our study of $\sim 55\%$ is higher than the 40% expected (Bergamaschi et al., 2000).

A weak point in coupling CO with CH_4 is that biomass burning has a larger effect on CO than on CH_4 (Andreae and Merlet, 2001). As a proxy for the biomass burning trend we consider the trend of CH_3Cl . Although the relationship between the CH_3Cl increase and biomass burning is not entirely clear (Aydin et al., 2004), biomass burning during the 20th century is believed to have mostly resulted in a CH_3Cl increase. To our knowledge, there are no other records (e.g., black carbon or soot in ice cores) for evaluating trends in biomass burning in the SH during the last century.

Overall, the use of CH_4 and CH_3Cl as a proxy aims to constrain the direction and shape of CO trend in a realistic way. Although a combination of the two proxies (in

proportions according to the CO budget) might be used, the two reconstructions are found practically identical (Fig. 11) so that this combination has not been tested. A difference compared to using CH₄ is that CH₃Cl has a shorter lifetime (but this is still longer than the CO lifetime) and thus these two proxies might have different response-time relative to source changes. Though a more sophisticated mathematical approach would result in a better reconstruction as well as quantification of the error budget, keeping in mind the limited number of depth levels and that only one firn site is under analysis, we consider the simple practical approach presented as rather a reasonable one.

4.3 Possible firn based sources of CO

CO production due to photo-oxidation of VOC adsorbed on snow may be considered as natural error source. Formaldehyde was suggested as a primary photo-oxidation CO source for a snow pack in the NH (Haan et al., 2001). At high latitudes formaldehyde is collected from polluted air by growing snow crystals and then transported for a long distance to the precipitation area (e.g. Perrier et al., 2002; Sumner et al., 2002). Freshly deposited snow in Antarctica has up to 6 ppbw formaldehyde (Hutterli et al., 2002), with a sharp decline below 1 m depth. Some of formaldehyde is released into atmosphere whereas some is in situ photo-oxidised thus producing CO. Taking 5 ppbw for the 30 cm firn depth (a year of accumulation at Berkner), a photolysis rate of $3.3 \cdot 10^{-5} \text{s}^{-1}$ (e.g. Haan et al., 2001 and references therein) and assuming that all formaldehyde is photo-oxidised (unfavorable case), ~ 2300 ppbv of CO would be produced within the 30 cm firn if the ventilation were zero. However, the upper firn is extremely well ventilated, about ~ 2900 times in 4 months. (A vertical air velocity is taken of 0.1 cm s^{-1} , a lower range of estimations for ~ 30 cm depth given by Albert, 2002 and Neumann and Waddington, 2004). Thus, if photo-oxidation of formaldehyde were completely in situ, it would elevate CO in the upper 30 cm firn for less than 1 ppbv and only during summer. As a significant part of adsorbed formaldehyde is removed to the atmosphere without being photo-oxidised in firn (e.g. Hutterli et al., 2004), we consider in situ photochemical CO production to be negligible. As in the case of other error sources, to get CO reconstructions that are less dependent on this (natural) error source, one should take samples at several firn sites with different accumulation rates.

5 Problems related to CO measurements and outlooks.

5.1 A comparison of our CO scale with the CO scale at NOAA/CMDL

The mean CO level of 52.5 ppbv obtained in two reconstructions over 1994 to 2002 (Fig. 9 and Fig. 10) is higher

than the average of 48.6 ppbv measured for the same period at the NOAA/CMDL Antarctic stations (Fig. 6). This gives the scale coefficient $k_2=1.08$. The observed discrepancy is in a reasonable agreement with previous inter-comparisons between our laboratory and NOAA/CMDL. While our absolute scale is based on volumetric determinations only (Brenninkmeijer et al., 2001), the NOAA/CMDL scale is based on CO standards stored in gas cylinders and the upward time drift of CO standards is known to be a serious problem (Novelli et al., 2003). Inter-comparisons conducted in 1993–1995 and 1998–1999 both indicated that the absolute volumetric method corresponded to the revised NOAA/CMDL scale with a factor of 1.04. On the other hand, Brenninkmeijer et al. (2001) reported a factor of 1.15, which would be translated into a factor of 1.11 when taking the scale revision by Novelli et al. (2003) into account. The comparisons also indicated larger discrepancies for CO mixing ratios around 50 ppbv than at the higher levels (180 and 350 ppbv), likely due to CO production in the cylinders during storage as discussed by (Novelli et al., 2003). Thus, the factor $k_2=1.08$ obtained in the present work is not significantly different from the known differences between the two laboratory scales.

Calibration issues might also contribute (besides background problems) to the differences in the CO concentrations of 57 ppbv reported by Haan and Raynaud (1998) in Antarctic ice for the year 1900 and our value of ~ 38 ppbv for this period.

5.2 Reconstruction of the $\delta^{13}\text{C}(\text{CO})$ trend

Information on isotope variations in trace gases are well known to assist in better understanding source and sink processes, and for firn air samples isotope analysis are considered useful. $\delta^{13}\text{C}(\text{CO})$ is known to be a sensitive indicator for CO sources. First, one can expect $\delta^{13}\text{C}(\text{CO})$ trend with depths to be smooth, and if sudden changes occur (as visible at DML and Dome C, Fig. 2), these are indicative for contamination and/or other problems. Second, subtle isotope signals are affected by firn air processes, like gravitation and diffusion. $\delta^{13}\text{C}(\text{CO})$ in firn is affected by the rapid CO growth in the atmosphere as the lighter molecule ^{12}CO diffuses faster downwards than ^{13}CO and thus $\delta^{13}\text{C}(\text{CO})$ is shifted in a negative direction. The corrections of $\delta^{13}\text{C}(\text{CO})$ were evaluated by running the model with the most likely CO scenario based on the CH₄ trend and a zero trend for $\delta^{13}\text{C}(\text{CO})$. The largest correction being for the deepest sample is $\sim +0.7$ ‰. The corrected $\delta^{13}\text{C}(\text{CO})$ data show a weakly-constrained positive trend (Fig. 12) implying isotopically heavier CO in the past. This agrees with the expectations based on a lower contribution of CO produced by CH₄ oxidation. (CH₄ is the most isotopically depleted precursor of CO, Manning et al. (1997).) Though $\delta^{13}\text{C}(\text{CH}_4)$ in the first half of 20th century was a few ‰ lower (Craig et al., 1988; Bräunlich et al., 2001; Ferretti et al., 2005; Sowers et al., 2005) relative to the modern value,

this small effect must have been overridden by the lesser role CH₄ oxidation played as a CO source in the past. The isotopic evolution of other CO sources cannot be estimated.

The oxygen isotope composition of CO could shed light on the oxidative capacity in the atmosphere. All the samples at Berkner have low $\delta^{18}\text{O}(\text{CO})$ values which indicate high degree of CO degradation by OH. Indeed, the high SH latitudes are far away from direct CO sources (e.g. biomass and fossil fuel burning) having positive $\delta^{18}\text{O}(\text{CO})$ values. Still, the scarcity of $\delta^{18}\text{O}(\text{CO})$ data limits its present use. Because the ratio of the changes in $\delta^{18}\text{O}(\text{CO})$ and $\delta^{17}\text{O}(\text{CO})$ caused in the reaction between CO and OH (Röckmann et al., 1998) deviates from the common pattern (Mass Independent Fractionation), $\Delta^{17}\text{O}(\text{CO})$ is a promising tracer of the atmospheric oxidative capacity, now and in the past. One may expect that $\delta^{18}\text{O}(\text{CO})$ combined with $\Delta^{17}\text{O}(\text{CO})$, when analysed on CO extracted from firn and ice cores, will give information on past OH levels.

6 Summary

CO concentrations and isotope ratios in firn air samples from Berkner Island (Antarctica) taken in January 2003 have been measured. The observed CO decrease with depth indicates lower CO levels in the past. The CO increase was at least 12% since 1968.

As CO age distributions were found to be broad and overlapping, an additional constraint was required to reconstruct the CO atmospheric trend. CO changes were assumed to be proportional to the change of CO sources, namely CH₄ oxidation and biomass burning. CH₃Cl was used as indicator of the later.

The most likely reconstruction based on the CH₄ trend corresponds to a CO increase from 38 ± 7 ppbv in 1900 to the level of 52.5 ± 1.5 ppbv in the years 1994 to 2002. The CO reconstruction being based on the atmospheric CH₃Cl trend is very similar to the one based on the methane trend.

The value 52.5 ± 1.5 ppbv inferred for the years 1994 to 2002 differs from the mean of 48.6 ppbv for CO measurements by NOAA/CMDL in Antarctica for the same years, likely due to a difference in calibration. As all measurements of firn air at Berkner were performed on the same scale and with a low value of overall blank, the conclusion of $\sim 38\%$ CO increase in Antarctica is beyond doubt. The $\delta^{13}\text{C}(\text{CO})$ data obtained for Berkner Island suggest that CO was isotopically heavier in the past, in agreement with a lower contribution of methane.

An obvious shortcoming of this work is the poor quantification of uncertainty from error sources such as signal smoothing in firn, the model and its calibration, seasonal fluctuations of firn parameters, CO seasonality, disturbance of air stratification and possible upwards depth bias (sampling effects), use of a proxy, CO production by VOC

oxidation in the firn, and calibration differences between NOAA/CMDL and our laboratory.

Ideally, data from different firn sites should be available in order to obtain robust and reliable reconstructions and to minimize contribution of various errors. Thus, the present work may be considered as the first, exploratory research aimed to reconstruct past CO levels. Here we note that a width of age distributions appears to be an important parameter for characterising the quality of the site. Besides, the CO seasonal cycle in the year preceding sampling should be known and should be introduced in the model running at an appropriate time step.

Acknowledgements. I. Levin kindly helped us with accurate SF₆ measurements. We thank the FIRETRACC and CRYOSTAT firn drilling expeditions in Antarctica for taking the samples and the LGGE team of the FIRETRACC and CRYOSTAT for calibrating firn diffusivity profiles. C. Koepfel kindly helped us by maintaining and running the CO extraction line. This work is a contribution to the European Commission project CRYOSTAT (EVK2-CT2001-00116) funded under the Energy, Environment and Sustainable Development Programme, 1998–2002; S. Assonov acknowledges participation in the project. We thank the editor A. Volz-Thomas for his constructive suggestions aimed to improve the manuscript.

Edited by: A. Volz-Thomas

References

- Albert, M. R., Effects of snow and firn ventilation on sublimation rates. *Ann. Glaciol.*, 35, 52–56, 2002.
- Andreae, M. O. and Merlet, P., Emission of trace gases and aerosols from biomass burning, *Global Biogeochem. Cyc.* 15, 955–966, 2001.
- Assonov, S. S., Brenninkmeijer, C. A. M., and Jöckel, P.: The ¹⁸O isotope exchange rate between firn air CO₂ and the firn matrix at three Antarctic sites, *J. Geophys. Res.-Atmos.*, 110, D18310 doi:10.1029/2005JD005769, 2005.
- Aydin, M., Saltzman, E. S., De Bruyn, W. J., Montzka, S. A. B., Butler, J. H., and Battle, M.: Atmospheric variability of methyl chloride during the last 300 years from an Antarctic ice core and firn air, *Geophys. Res. Lett.*, 21, L02109, doi:10.1029/2003GL018750, 2004.
- Bergamaschi, P., Hein, R., Heimann, M., and Crutzen, P. J.: Inverse modeling of the global CO cycle 1, Inversion of CO mixing ratios, *J. Geophys. Res.-Atmos.*, 105, 1909–1927, 2000.
- Bräunlich, M., Aballain, O., Marik, Th., et al.: Changes in the global atmospheric methane budget over the last decades inferred from ¹³C and D isotopic analysis of Antarctic firn air, *J. Geophys. Res.-Atmos.*, 106, 20465–20481, 2001.
- Brenninkmeijer, C. A. M.: Measurement of the abundance of ¹⁴CO in the atmosphere and the ¹³C/¹²C and ¹⁸O/¹⁶O ratio of atmospheric CO with applications in New-Zealand and Antarctica, *J. Geophys. Res.-Atmos.*, 98, 10595–10614, 1993.
- Brenninkmeijer, C. A. M., Manning, M. R., Lowe, D. C., Wallace, G., Sparks, R. J., and Volz-Thomas, A.: Interhemispheric

- asymmetry in OH abundance inferred from measurements of atmospheric ^{14}CO , *Nature*, 356, 50–52, 1992.
- Brenninkmeijer, C. A. M., Koepfel, C., Röckmann, T., Scharffe, D. S., Bräunlich, M., and Gros, V.: Absolute measurement of the abundance of atmospheric carbon monoxide. *J. Geophys. Res.-Atmos.*, 106, 10 003–10 010, 2001.
- Brunke, E. G., Scheel, H. E., and Seiler, W.: Trends of Tropospheric CO, N_2O and CH_4 as observed at Cape Point, South-Africa, *Atmos. Environ. Part A - Gen.*, 24, 585–595, 1990.
- Butler, J. H., Battle, M., Bender, M. L., et al.: A record of atmospheric halocarbons during the twentieth century from polar firn air, *Nature*, 399, 749–755, 1999.
- Butler, T. M., Rayner, P. J., Simmonds, I., and Lawrence, M. G.: Simultaneous mass balance inverse modeling of methane and carbon monoxide, *Geophys. Res.-Atmos.*, 110, D21310, doi:10.1029/2005JD006071, 2005.
- Cainey, J. M., Derek, N., and Krummel, P. B.: Baseline Atmospheric Program (Australia) 2001–2002, Melbourne, 2004.
- Craig, H., Chou, C. C., Welhan, J. A., Stevens, C. M., and Engelke-meir, A.: The isotopic composition of methane in polar ice cores, *Science*, 242, 1535–1539, 1988.
- Etheridge, D. M., Steele, L. P., Francey, R. J., and Langenfelds, R. L.: Atmospheric methane between 1000 AD and present: Evidence of anthropogenic emissions and climatic variability, *J. Geophys. Res.-Atmos.*, 103, 15 979–15 993, 1998.
- Fabre, A., Barnola, J. M., Arnaud, L., and Chappellaz, J.: Determination of gas diffusivity in polar firn: Comparison between experimental measurements and inverse modeling, *Geophys. Res. Lett.*, 27, 557–560, 2000.
- Ferretti, D. F., Miller, J. B., White, J. W. C., et al.: Unexpected changes to the global methane budget over the past 2000 years, *Science*, 309, 1714–1717, 2005.
- Haan, D. and Raynaud, D.: Ice core record of CO variations during the last two millennia: atmospheric implications and chemical interactions within the Greenland ice, *Tellus Ser. B*, 50, 253–262, 1998.
- Haan, D., Zuo, Y., Gros, V., and Brenninkmeijer, C. A. M.: Photochemical production of carbon monoxide in snow, *J. Atmos. Chem.*, 40, 217–230, 2001.
- Hutterli, M. A., Bales, R. C., McConnell, J. R., and Stewart, R. W.: HCHO in Antarctic snow: Preservation in ice cores and air-snow exchange, *Geophys. Res. Lett.*, 29, 1235, doi:10.1029/2001GL014256, 2002.
- Hutterli, M. A., McConnell, J. R., Chen, G., Bales, R. C., Davis, D. D., and Lenschow, D. H.: Formaldehyde and hydrogen peroxide in air, snow and interstitial air at South Pole. *Atmos. Environ.*, 38, 5439–5450, 2004.
- Kaspers, K. A., van de Wal, R. S. W., de Gouw, J. A., et al.: Seasonal cycles of nonmethane hydrocarbons and methyl chloride, as derived from firn air from Dronning Maud Land, Antarctica. *J. Geophys. Res.-Atmos.*, 109, D02307, doi:10.1029/2003JD003950, 2004.
- Khalil, M. A. K. and Rasmussen, R. A.: Carbon-Monoxide in the Earths Atmosphere—Indications of a Global Increase, *Nature*, 332, 242–245, 1988.
- Mak, J. E. and Brenninkmeijer, C. A. M.: Compressed-air sample technology for isotopic analysis of atmospheric carbon monoxide, *J. Atmos. Oceanic Technol.*, 11, 425–431, 1994.
- Manning, M. R., Brenninkmeijer, C. A. M., and Allan, W.: Atmospheric carbon monoxide budget of the southern hemisphere: Implications of $^{13}\text{C}/^{12}\text{C}$ measurements, *J. Geophys. Res.-Atmos.*, 102, 10 673–10 682, 1997.
- Manning, M. R., Lowe, D. C., Moss, R. C., Bodeker, G. E. and Allan, W.: Short term variations in the oxidising power of the atmosphere, *Nature*, 436 (7053), 1001–1004, 2005.
- Mulvaney, R. Oerter, H., Peel, D. A., et al.: 1000 year ice-core records from Berkner Island, Antarctica, *Ann. Glaciol.*, 35, 45–51, 2002.
- Neumann, T. A. and Waddington, E. D.: Effects of firn ventilation on isotopic exchange, *J. Glaciology*, 50, 183–194, 2004.
- Novelli, P. C.: CO in the atmosphere: measurement techniques and related issues, *Chemosphere - Global Change Science*, 1, 115–126, 1999.
- Novelli, P. C., Connors, V. S., Reichle, H. G., et al.: An internally consistent set of globally distributed atmospheric carbon monoxide mixing ratios developed using results from an intercomparison of measurements, *J. Geophys. Res.-Atmos.*, 103, 19 285–19 293, 1998a.
- Novelli, P. C., Masarie, K. A. and Lang, P. M.: Distributions and recent changes of carbon monoxide in the lower troposphere, *J. Geophys. Res.-Atmos.*, 103, 19 015–19 033, 1998b.
- Novelli, P. C., Masarie, K. A., Lang, P. M., Hall, B. D., Myers, R. C., and Elkins, J. W.: Reanalysis of tropospheric CO trends: Effects of the 1997–1998 wildfires, *J. Geophys. Res.-Atmos.*, 108, 4464, doi:10.1029/2002JD003031, 2003.
- Perrier, S., Houdier, S., Domine, F., et al.: Formaldehyde in Arctic snow. Incorporation into ice particles and evolution in the snow-pack, *Atmos. Environ.*, 36, 2695–2705, 2002.
- Röckmann, T. Brenninkmeijer, C. A. M., Saueressig, G., et al.: Mass-independent oxygen isotope fractionation in atmospheric CO as a result of the reaction $\text{CO}+\text{OH}$, *Science*, 281, 544–546, 1998.
- Röckmann, T., Kaiser, J., and Brenninkmeijer, C. A. M.: The isotopic fingerprint of the pre-industrial and the anthropogenic N_2O source, *Atmos. Chem. Phys.* 3, 315–323, 2003.
- Rommelaere, V., Arnaud, L., and Barnola, J. M.: Reconstructing recent atmospheric trace gas concentrations from polar firn and bubbly ice data by inverse methods, *J. Geophys. Res.-Atmos.*, 102, 30 069–30 083, 1997.
- Schwander, J.: The transformation of snow to ice and the occlusion of gases, in *The Environmental Record in Glaciers and Ice Sheets*, edited by: Oeschger, H. and Langway Jr., C. C., pp. 53–67, John Wiley, New York, 1989.
- Severinghaus, J. P., Grachev, A., and Battle, M.: Thermal fractionation of air in polar firn by seasonal temperature gradients, *Geochem. Geophys. Geosyst.*, 2, art. no. 2000GC000146, 2001.
- Sowers, T., Bernard, S., Aballain, O., Chappellaz, J., Barnola, J.-M., and Marik, T.: Records of the $\delta^{13}\text{C}$ of atmospheric CH_4 over the last 2 centuries as recorded in Antarctic snow and ice, *Global Biogeochem. Cyc.*, 19, GB2002, doi:10.1029/2004GB002408, 2005.
- Sturges, W. T., McIntyre, H. P., Penkett, S. A., et al.: Methyl bromide, other brominated methanes, and methyl iodide in polar firn air, *J. Geophys. Res.-Atmos.*, 106, 1595–1606, 2001a.
- Sturges, W. T., Penkett, S. A., Barnola, J. M., Chappellaz, J., Atlas, E. and Stroud, V.: A long-term record of carbonyl sulfide (COS) in two hemispheres from firn air measurements, *Geophys. Res. Lett.*, 28, 4095–4098, 2001b.

- Sumner, A. L., Shepson, P. B., Grannas, A. M., et al.: Atmospheric chemistry of formaldehyde in the Arctic troposphere at Polar Sunrise, and the influence of the snowpack. *Atmos. Environ.*, 36, 2553–2562, 2002.
- Trudinger, C. M., Etheridge, D. M., Rayner, P. J., Enting, I. G., Sturrock, G. A., and Langenfelds, R. L.: Reconstructing atmospheric histories from measurements of air composition in firn, *J. Geophys. Res.-Atmos.*, 107, doi:10.1029/2002JD002545, 2002.
- Trudinger, C. M., Etheridge, D. M., Sturrock, G. A., Fraser, P. J., Krummel, P. B., and Mcculloch, A.: Atmospheric histories of halocarbons from analysis of Antarctic firn air: Methyl bromide, methyl chloride, chloroform, and dichloromethane, *J. Geophys. Res.-Atmos.*, 109, D22310 doi:10.1029/2004JD004932, 2004.
- Volz, A., Ehhalt, D. H., and Derwent, R. G.: Seasonal and latitudinal variation of ^{14}CO and tropospheric concentration of OH radicals, *J. Geophys. Res.-Oceans and Atmos.*, 86, 5163–5171, 1981.
- Weiler, K., Schwander J., Leuenberger, M., et al.: *Geophys. Res. Abstracts*, presentation on EGU-2005, 7, 03632, 2005.