



**HAL**  
open science

## The hardness of routing two pairs on one face

Guyslain Naves

► **To cite this version:**

| Guyslain Naves. The hardness of routing two pairs on one face. 2008. hal-00313944v1

**HAL Id: hal-00313944**

**<https://hal.science/hal-00313944v1>**

Preprint submitted on 27 Aug 2008 (v1), last revised 16 Nov 2009 (v2)

**HAL** is a multi-disciplinary open access archive for the deposit and dissemination of scientific research documents, whether they are published or not. The documents may come from teaching and research institutions in France or abroad, or from public or private research centers.

L'archive ouverte pluridisciplinaire **HAL**, est destinée au dépôt et à la diffusion de documents scientifiques de niveau recherche, publiés ou non, émanant des établissements d'enseignement et de recherche français ou étrangers, des laboratoires publics ou privés.

# The hardness of routing two pairs on one face

Guyslain Naves

Laboratoire G-SCOP

August 27, 2008

## Abstract

We prove the NP-completeness of the integer multiflow problem in planar graphs, with the following restrictions: there are only two edges of demand, both lying on the infinite face of the routing graph. It solves a question from Müller [5]. We also give a directed version with only two terminals, and a directed acyclic version, both with only two arcs of demand.

## 1 Introduction

The multiflow problem has been studied in combinatorial optimization from many years, because of both the interesting theoretical results in connectivity and flow theory, and practical applications in industrial problems such as VLSI-layout. Basically, we want to find integer flows between pairs of terminals, respecting capacity constraints.

The general problem is NP-complete, with different types of constraints, see e.g. the survey of Frank [2]. The most general way to define constraints is to put capacities on the edges of the graph, in the same way as the classical flow problem. When these capacities are 1 everywhere, it defines the edge-disjoint (or arc-disjoint) paths problem. Robertson and Seymour [8] proved that the multiflow problem is polynomial for undirected graphs, assuming that the total amount of demand is fixed.

A special interest has been shown for solving the problem in planar graphs (directed or not), as many applications use this property. Unfortunately, Kramer and Van Leeuwen [3] show that the undirected planar multiflow problem is NP-complete in the general case. Nevertheless, a good characterization has been found by Okamura and Seymour [6] for the edge-disjoint paths problem in planar Eulerian graphs, under the assumption that all terminals of routing pairs are on the boundary of a unique face of the graph. Some improvements have been made (see [1], [7]), but it was still open in 2006 to know if there exists a good characterization for non-Eulerian graphs. In 2007, Schwärzler [10] proved the NP-completeness of the edge-disjoint paths problem in planar graph with all terminals in the boundary of a unique face of the graph.

Between Robertson and Seymour's result, and Schwärzler's result, one could ask if there is a polynomial-time algorithm for the edge-disjoint paths problem in planar graphs, when the number of pairs of terminals is fixed, especially when there are only two pairs of terminals lying on a single face of the graph. Actually, Schwärzler's proof can easily be modified to prove that the problem is still NP-complete with three pairs of terminal. In this paper we give an original reduction, proving that the problem is polynomial with only two pairs of terminals. It solves a question from Müller [5].

We will also give a directed version of our proof, proving that the arc-disjoint paths problem is NP-complete, even when  $G$  is planar with two opposite routing pairs  $st$  and  $ts$  where vertices  $s$  and  $t$  belong to the boundary of a single face of  $G$ . Both results strengthen [5]. Finally, we prove the NP-completeness when  $G$  is a planar acyclic digraph and  $H$  consists of two pairs of terminals lying on the outer face of  $G$ .

The paper is organized as follows: Section 2 recalls useful definitions and presents the problem. Section 3.1 contains a topological lemma, about assumptions that can be made upon a solution to a planar multiflow problem. The aim of Section 3.2 is to give an intuition about the complicated reduction that proves the main theorem. This reduction will use some graphs introduced in Section 3.3. Section 3.4 presents a way to build big graphs, replacing vertices of a grid by other graphs.

The main theorem, about the undirected multiflow problem is proved in Section 4. Section 5 and Section 6 argue about the cases when  $G + H$  is a planar digraph and when  $G$  is an acyclic digraph respectively.

## 2 Definitions

Let  $G = (V, E)$  be an undirected graph, and let  $c : E \rightarrow \mathbb{N}$  be a *capacity function* on the edges of  $G$ . Let  $H = (T, D)$  be an undirected graph with  $T \subseteq V$ , and  $r : D \rightarrow \mathbb{N}$  a *request function*. The *multiflow problem* is to find a multiset  $\mathcal{C}$  of cycles of  $G + H$  satisfying the following conditions :

- (i) Each cycle of  $\mathcal{C}$  contains exactly one edge of  $H$ .
- (ii) For each edge of  $G$ , the number of cycles in  $\mathcal{C}$  using it is less than its capacity.
- (iii) For each edge of  $H$ , the number of cycles in  $\mathcal{C}$  using it is exactly its request.

$H$  is usually called the *demand graph*,  $T$  is the set of *terminals*. By cycle, we mean a closed sequence of disjoint edges that are consecutive in the graph, that is a connected Eulerian subgraph. The problem can easily be defined in digraphs, by replacing every occurrence of “cycle” by “directed cycle”. Thus, an instance of the multiflow problem consists of a quadruple  $(G, H, r, c)$ , but we will usually omit the mention of  $r$  and  $c$ . In the following, when  $r$  or  $c$  are not explicitly defined on some edge, they are supposed to be equal to 1. Note that the encoding of  $r$  and  $c$  will be supposed to be in unary. Equivalently, our NP-completeness results are all strong. We will note by  $\mathcal{P}$  the set of paths obtained from  $\mathcal{C}$  by ignoring the demand edges.

The graphs considered in this paper are always without loops, but parallel edges are allowed. Actually, whenever a edge  $e \in E(G)$  has a capacity greater than 1, we replace it by  $c(e)$  parallel edges. Let  $U \in V$  be a subset of a vertex set of the graph. We note  $\delta(U)$  the set of edges having exactly one extremity in  $U$ . Every set of edges that can be written as  $\delta(U)$  for some  $U$  is called a *cut* of the graph. In directed graphs,  $\delta^-(U)$  is the set of edges entering  $U$ ,  $\delta^+(U)$  is the set of edges leaving  $U$ . When  $\delta(U) = \delta^+(U)$ , we say that  $U$  is a *directed cut*. We define  $d(U) := |\delta(U)|$  and similarly  $d^+(U)$  and  $d^-(U)$ .

An important concept in the multiflow theory is the one of tight cut. Let  $C$  be a cut of  $G + H$ .  $C$  is a *tight cut* if  $c(C \cap E) - r(C \cap D) = 0$ . If this difference is negative, the multiflow problem is not feasible. When  $H$  is reduced to a single edge, the famous *max-flow-min-cut* result states that the multiflow exists if and only if this difference is never negative (see Menger’s theorem [4]). When  $C$  is a tight cut, in any solution to the multiflow problem, each edges of  $C$  is totally used : there is as many cycles through each edge as the capacity or request of the edge. In directed graph, tight cuts are those cuts of  $G + \overleftarrow{H}$  with  $c(C \cap E) - r(C \cap \overleftarrow{D}) = 0$ , where  $\overleftarrow{H} = (T, \overleftarrow{D})$  is the graph obtained from  $H$  by changing the orientation of each arc.

A *planar graph* is a graph that admits an embedding in the plane without intersection of the edges. Let  $G$  be a planar graph, we can suppose that an embedding is given, as it can be built in polynomial time, thus the embedding will now be implicit throughout this paper. Two paths  $P_1$  and  $P_2$  are said to *cross* at node  $v$  in the embedding if  $P_1$  contains edges  $(u_1, v)$ ,  $(v, u_2)$ ,  $P_2$  contains  $(u_3, v)$ ,  $(v, u_4)$ , and  $(v, u_1)$ ,  $(v, u_3)$ ,  $(v, u_2)$  and  $(v, u_4)$  appears in that order around the node  $v$  in the current embedding of  $G$  (see Figure 1). This notion is also defined in directed graph.

A *path* is a sequence of disjoint edges that are consecutive. Thus, cycles are closed paths. Two paths are *edge-disjoint* if their edge-sets are disjoint. Equivalently, we define *directed paths* and *arc-disjoint paths*. When  $c$  is constantly equal to 1, the multiflow problem is known as the *edge-disjoint paths problem* (resp. the *arc-disjoint paths problem*), as the cycles of a solution becomes edge-disjoint paths linking the pairs of terminals corresponding to their demand edges, when removing these last edges in every cycle.

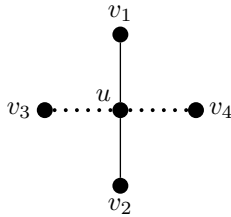

Figure 1: *The dotted path (from  $v_3$  to  $v_4$ ) cross the plain path (from  $v_1$  to  $v_2$ ) at node  $u$ . A path from  $v_1$  to  $v_3$  would not cross a path from  $v_2$  to  $v_4$ , even if they intersect.*

### 3 Preliminaries

#### 3.1 Paths-uncrossing

The following lemma will be useful to study the behaviour of paths in the next sections.

**Lemma 1 (Paths-uncrossing)**

Let  $(G, H)$  be an instance of the planar multiflow problem, suppose  $c$  is 1 everywhere. Then there exists a solution to the problem  $(G, H)$  if and only if there exists a solution such that no two paths of that solution cross each other strictly more than once.

*Proof*

Let  $\mathcal{P}$  be a solution of  $(G, H)$  with a minimal number of crossings. We can suppose that the paths in  $\mathcal{P}$  are simple. Suppose there exist two paths  $P_1$  and  $P_2$  in  $\mathcal{P}$  that cross each other more than once. Let  $x$  and  $y$  be respectively the first and the last vertices of  $V(P_1) \cap V(P_2)$  met when walking along  $P_1$ .  $x$  and  $y$  are distinct because paths are simple.  $P_1$  and  $P_2$  can both be divide in three paths:  $P_i^x$ ,  $P_i^y$  and  $P_i^{xy}$ , where paths have their exponents among their extremities. In  $\mathcal{P}$ , we replace  $P_1$  and  $P_2$  by  $P'_1 = P_1^x \cup P_2^{xy} \cup P_1^y$  and  $P'_2 = P_2^x \cup P_1^{xy} \cup P_2^y$ . We prove that this solution has less crossings than  $\mathcal{P}$ , this would lead to a contradiction.

In every other vertex than  $x$  and  $y$ , the number of crossing has not changed (because locally, paths have not changed either). In both  $x$  and  $y$ , the crossings between  $P_1$  and  $P_2$  have been deleted.  $P_1$  and  $P_2$  divide the neighbourhood of  $x$  (and symmetrically  $y$ ) in four parts,  $Q_1$  to  $Q_4$  in clockwise order. A path from two consecutive parts cross one of  $P_1$  and  $P_2$ , and one of  $P'_1$ ,  $P'_2$ . A path between two opposite quarter cross both  $P_1$  and  $P_2$ . Then the number of crossing can only be decreased. □

A set of paths that do not cross more than once each other is said to be uncrossed.

#### 3.2 Intuitions

Before formally proving the NP-completeness of the edge-disjoint paths problem in planar graphs, we give intuitions about the reduction. We will reduce from 3-SAT. The main part of the reduction is to build a large grid, with two rows for each variable of the formula, and one column per clause. Three “horizontal” paths will go through the two rows of each variable, either one on the upper and two in the lower row, or the opposite, encoding the assignment of the variable. There are four edges between two successive squares of the same column. Two “vertical” paths will flow through each column, taking two among these four edges between each square, alternatively the two left-most edges or the two right-most edges. These paths will encode whether the clause is satisfied by the variable assignment: the clause has not yet been satisfied if the two paths have respected the strict alternance between right-hand side and left-hand side. The alternance will be ensured by gadgets chosen for each square of the grid. When a assignment of a variable satisfies a clause, that is when one horizontal path cross two vertical paths in one special square of the grid, and only under this condition, the two vertical paths have in the corresponding square the possibility to stay in the same side of the column. Using the parity of the number of rows, we will enforce that this occurs an odd number of times in each column in any solution, in particular at least once. This will prove that the disjoint paths problem is solvable if and only if the formula is satisfiable.

However these relatively simple ideas are not sufficient to provide a sound reduction. Indeed, the construction will not ensure that the horizontal paths go through only one row of the grid, and we

did not find any possibility to force this property. Consequently, we will allow horizontal paths to go from one row to another. Such a movement consumes nevertheless some “potential”, and can be done only a limited number of time. By adding a large number of new rows, we will compensate the freedom of paths. There will be rows between two consecutive variables, and rows between the two original rows of each variable. Thus, no variable will have both a true and a false assignment. To prove this, we will largely use the fact that about all the vertices of the graph have an even degree.

### 3.3 Special graphs

In this section, we introduce two special graphs that will be useful in the proof of theorem 9. We introduce a local gadget replacing some nodes of degree-four of  $G$  in the following way, that have the property to forbid the crossing of two paths in these nodes. As we want to control where the horizontal and vertical paths can cross each others, most of the vertices will indeed be replaced.

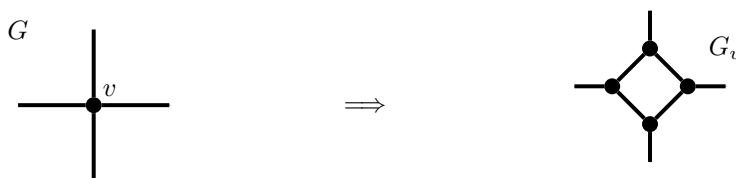

Figure 2: *This gadget replace a degree-four vertex by a small gadget, forbidding the crossing of two paths at this vertex.*

**Problem** (Extended planar multifold problem)

INPUT: a planar graph  $G$ ,  $U \subseteq V(G)$ , a graph  $H$  with  $V(H) \subseteq V(G)$ ,  $r$  and  $c = 1$ .

OUTPUT: Is there a solution to the planar multifold problem  $(G, H)$  such that in each node  $u \in U$ , the paths that meet in  $u$  do not cross ?

Note that when  $U = \emptyset$ , it is exactly the planar edge-disjoint paths problem. for a given graph  $G$  with a vertex  $v$  of degree four,  $G_v$  is defined in Figure 2.

**Proposition 2**

Let  $(G, H, U)$  be an instance of the extended planar edge-disjoint paths problem, and  $v \in V(G)$  with  $d(v) = 4$ . There exists a solution of the extended planar edge-disjoint paths problem  $(G_v, H, U)$  if and only if there exists a solution of the extended planar edge-disjoint paths problem  $(G, H, U \cup \{v\})$ .

Thus the extension is in fact equivalent to the original problem. We will call non-cross nodes the vertices of  $U$ . In the sequel, we will only speak about the extended planar edge-disjoint paths problem. In the pictures, normal nodes will be drawn with a big point, whereas special non-cross nodes will be drawn with a small point. Thus big nodes are those where paths can cross. Note that by using this trick, the reduction will use a very small number of vertices of odd degree.

The following two graphs are the main bricks of the reduction. We prove some basic results about these graphs, mainly how paths can be crossed in them. Let XCH be the graph presented in figure 3. In the following, we note  $S = \{s_1; s_2; s_3; s_4\}$ ,  $S' = \{s'_1; s'_2; s'_3; s'_4\}$ ,  $T = \{t_1; t_2\}$  and  $T' = \{t'_1; t'_2\}$ . Note that there are only four vertices,  $a, b, c$ , and  $d$ , where crossings of paths are allowed.

The goal of this graph XCH is to encode the fact that whatever is the number of horizontal paths going through it, one or two, the vertical paths must go from one side to the other. This graph will encode that a literal is not in a given clause. More usually, it also ensures that the two vertical paths enter it by the same side, both on the left or both on the right. Next propositions shows these properties.

**Proposition 3**

Let  $\mathcal{P} = \{S_1, S_2, T_1, T_2\}$  be a set of feasible edge-disjoint paths in XCH that verifies :

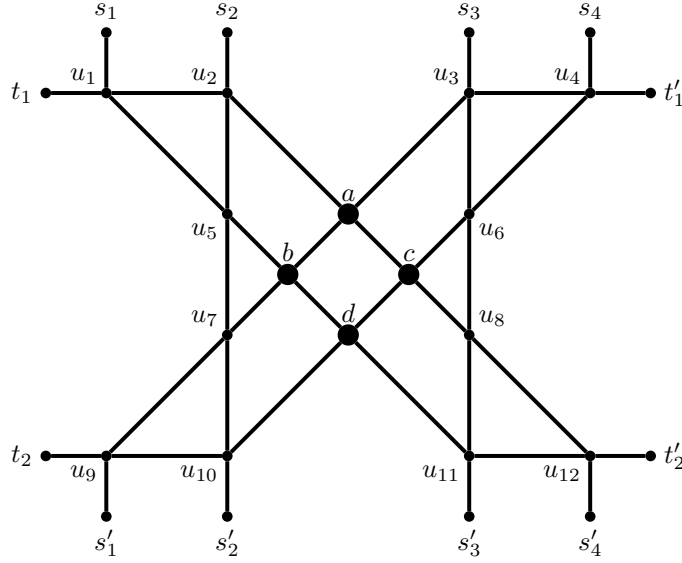

Figure 3: The graph  $XCH$ , with four crossing nodes. It will encode the fact that a literal is not in a given clause.

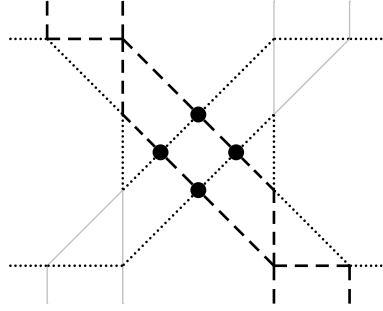

Figure 4: Existence of 2  $(T, T')$ -paths and 2  $(S, S')$ -paths, pairwise edge-disjoint. The  $(S, S')$ -paths can not stay on the same side of the graph.

- (i)  $S_1, S_2$  are  $(S, S')$ -paths,
- (ii)  $T_1, T_2$  are  $(T, T')$ -paths.

Then, either  $\{S_1, S_2\}$  consists of a  $(s_1, s'_3)$ -path and a  $(s_2, s'_4)$ -path, or of a  $(s_3, s'_1)$ -path and a  $(s_4, s'_2)$ -path.

*Proof*

Let  $\mathcal{P}$  be as described in the proposition. As the  $(S, S')$ -paths must cross the  $(T, T')$ -paths, there are at least 4 crossings in  $\mathcal{P}$  and we know that these occur in vertices  $a, b, c$  and  $d$ , and the  $(T, T')$ -paths (resp. the  $(S, S')$ -path) do not cross each other.

Suppose  $(a, b)$  is in a  $(S, S')$ -path, then  $(a, c)$  and  $(b, d)$  must belong to distinct  $(T, T')$ -paths, and  $(c, d)$  is in the second  $(S, S')$ -path. Then  $(a, u_2), (b, u_5), (c, u_8), (d, u_{11})$  are in  $(T, T')$  paths, and  $(a, u_3), (b, u_7), (c, u_6)$  and  $(d, u_{10})$  are in  $(S, S')$ -paths. As there is no other crossing except in the four central vertices, the  $(S, S')$ -paths are connected to  $s'_1, s'_2, s_3$  and  $s_4$ . The case when  $(a, b)$  belongs to a  $(T, T')$ -path is exactly the same by symmetry and give the other solution.  $\square$

These paths exist, as shown by Figure 4.

#### Proposition 4

Let  $\mathcal{P}$  be a set of edge-disjoint paths in  $XCH$  that verifies :

- (i)  $\mathcal{P}$  contains exactly 2  $(\{s_1, s_2\}, S'')$ -paths, where  $S''$  is either  $\{s'_1, s'_2\}$  or  $\{s'_3, s'_4\}$ ,

(ii)  $\mathcal{P}$  contains exactly 1  $(T, T')$ -paths,

Then,  $S'' = \{s'_3, s'_4\}$ .

*Proof*

If not, then there is a set  $\mathcal{P}$  of three edge-disjoint paths, a  $(t, t')$ -path  $Q$ , a  $(s_1, s'_1)$ -path  $P_1$  and a  $(s_2, s'_2)$ -path  $P_2$ . As  $Q$  must cross the two other paths, all paths go through at least one of  $a, b, c$  and  $d$ . Then,  $Q$  uses one edge of  $u_2a, u_5b, u_7b, u_{10}d$ , and both  $P_1$  and  $P_2$  uses two of these edges, contradicting the edge-disjointness of the paths.  $\square$

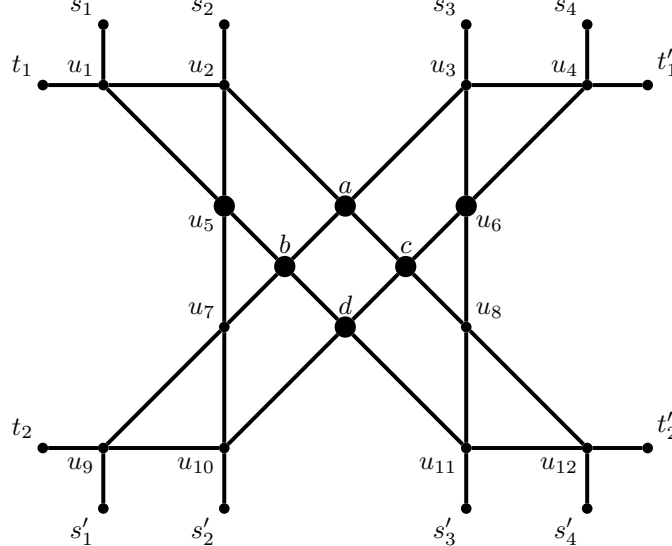

Figure 5: The graph LIC, with 6 crossing nodes. It will encode the occurrence of a literal in a clause

Let LIC be the graph of Figure 5. Again, we note  $S = \{s_1; s_2; s_3; s_4\}$ ,  $S' = \{s'_1; s'_2; s'_3; s'_4\}$ ,  $T = \{t_1; t_2\}$  and  $T' = \{t'_1, t'_2\}$ . Note that it is almost the same graph as XCH, except that both  $u_5$  and  $u_6$  allows possible crossings of paths.

This is the graph that will encode that a literal is in the present clause. That is, when there is only one horizontal path using it, the two vertical paths using it can enter and leave on the same side of the gadget, left or right. But when two horizontal paths use it, then the clause is not satisfied by this literal: the two vertical paths can not stay on the same side. Formally:

**Proposition 5**

Let  $\mathcal{P}$  be a set of edge-disjoint paths in LIC that verifies :

(i)  $\mathcal{P}$  contains exactly 2  $(\{s_1, s_2\}, S'')$ -paths, where  $S''$  is either  $\{s'_1, s'_2\}$  or  $\{s'_3, s'_4\}$ ,

(ii)  $\mathcal{P}$  contains exactly 2  $(T, T')$ -paths,

Then,  $S'' = \{s'_3, s'_4\}$ . Moreover, there can not be another  $(S \cup T, S' \cup T')$ -path.

*Proof*

Suppose  $S'' = \{s'_1, s'_2\}$ . Let  $C$  be the cut  $\{u_7, u_9, u_{10}\}$ . Let  $Q$  be the  $(t_2, T')$ -path,  $P_1$  the  $(s_1, s'_1)$ -path and  $P_2$  the  $(s_2, s'_2)$ -path. These three different paths go through  $C$ , and  $d(C) = 6$ . Moreover, there is no crossing in  $C$ , thus considering  $\delta(C)$ ,  $u_5u_7$  is used by  $Q$  and  $bu_7, du_{10}$  by  $P_1$  and  $P_2$ . Now, there are four distinct paths entering  $C' = \{u_1, u_2, u_5\}$ , but  $d(C') = 6$ , contradiction.

As the edges of  $\delta(\{a, b, c, d\})$  are all used by  $\mathcal{P}$ , there are no other  $(S \cup T, S' \cup T')$ -path.  $\square$

**Proposition 6**

There exist a  $(T, T')$ -path  $P$ , a  $(s_1, s'_1)$ -path  $P_1$  and a  $(s_2, s'_2)$ -path  $P_2$ , pairwise edge-disjoint, in LIC.

There exist a  $(T, T')$ -path  $P$ , a  $(s_3, s'_3)$ -path  $P_1$  and a  $(s_4, s'_4)$ -path  $P_2$ , pairwise edge-disjoint, in

LIC.

*Proof*

See Figure 6. □

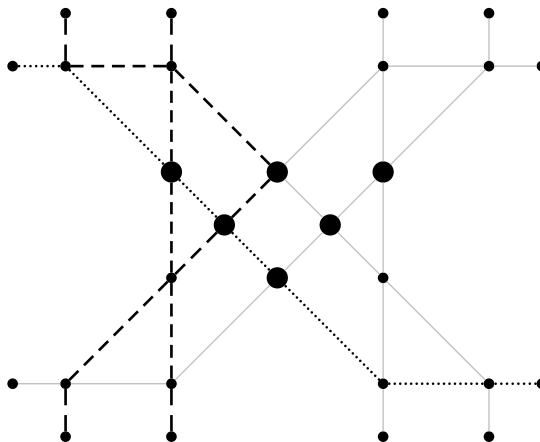

Figure 6: *Existence of a  $(T, T')$ -path plus 2  $(S, S')$ -paths in LIC, pairwise edge-disjoint, such that the two  $(S, S')$ -paths stay on the same side of the graph.*

### 3.4 Grids of gadgets

In this section, we define some graphs built by connecting between them instances of graphs LIC and XCH. A grid of dimension  $p \times n$  is a graph defined by taking  $p \times n$  instances of graphs LIC and XCH, call it  $M(i, j)$ ,  $i \in \llbracket 1, p \rrbracket$ ,  $j \in \llbracket 1, n \rrbracket$  and connecting them by adding one edge between each vertex of  $S, S', T$  and  $T'$  of  $M(i, j)$  and its counterpart in  $M(i + \alpha, j + \beta)$ ,  $\alpha, \beta \in \llbracket -1, 1 \rrbracket$ ,  $|\alpha + \beta| = 1$ . An example with notations is given in figure 7. If  $M(i, j)$  is XCH (resp. LIC), and  $u \in V(\text{XCH})$  (resp.  $u \in V(\text{LIC})$ ), we will note  $u^{i,j}$  the corresponding node in  $M(i, j)$ . We define  $X := \{x_i : i \in \llbracket 1, 4n \rrbracket\}$ ,  $X' := \{x'_i : i \in \llbracket 1, 4n \rrbracket\}$ ,  $Y := \{y_i : i \in \llbracket 1, 2p \rrbracket\}$ , and  $Y' := \{y'_i : i \in \llbracket 1, 2p \rrbracket\}$ .

In the following, row  $i$  ( $i \in \llbracket 1, p \rrbracket$ ) will refer to the subgraph of the grid induced by the  $(M(i, j))_{j \in \llbracket 1, n \rrbracket}$ , and column  $j$  to the subgraph induced by the  $(M(i, j))_{i \in \llbracket 1, p \rrbracket}$ .  $(X, X')$ -paths (resp.  $(Y, Y')$ -paths) will be called vertical paths (resp. horizontal paths). If  $\mathcal{P}$  is a set of edge-disjoint paths of the graph  $G$ ,  $G - \mathcal{P}$  is the graph obtained from  $G$  by removing all the edges used in  $\mathcal{P}$ .

Two paths are said to be parallel if they are both horizontal or both vertical. Two paths are said perpendicular if one is horizontal and the other vertical.

#### Lemma 7

Let  $P_1$  and  $P_2$  two parallel paths of an uncrossed edge-disjoint set  $\mathcal{P}$  of  $(X, X')$ -paths and  $(Y, Y')$ -paths. Then,  $P_1$  and  $P_2$  cross all their perpendicular paths in the same order.

*Proof*

This is an obvious consequence of uncrossing. □

#### Lemma 8

Let  $G$  be a grid of dimension  $p \times n$ . Let  $\mathcal{P}$  be an uncrossed set of  $(X, X')$ -paths and  $(Y, Y')$ -paths pairwise edge-disjoint. Suppose there exists  $i \in \llbracket 1, p - 1 \rrbracket$  such that for all  $j \in \llbracket 1, n \rrbracket$ ,  $M(i, j)$  and  $M(i + 1, j)$  are XCH and there are exactly four crossings of paths of  $\mathcal{P}$  in  $M(i, j)$  and in  $M(i + 1, j)$ . Then, there is no path in  $G - \mathcal{P}$  between a vertex of row  $i - 1$  and a vertex of row  $i + 2$ .



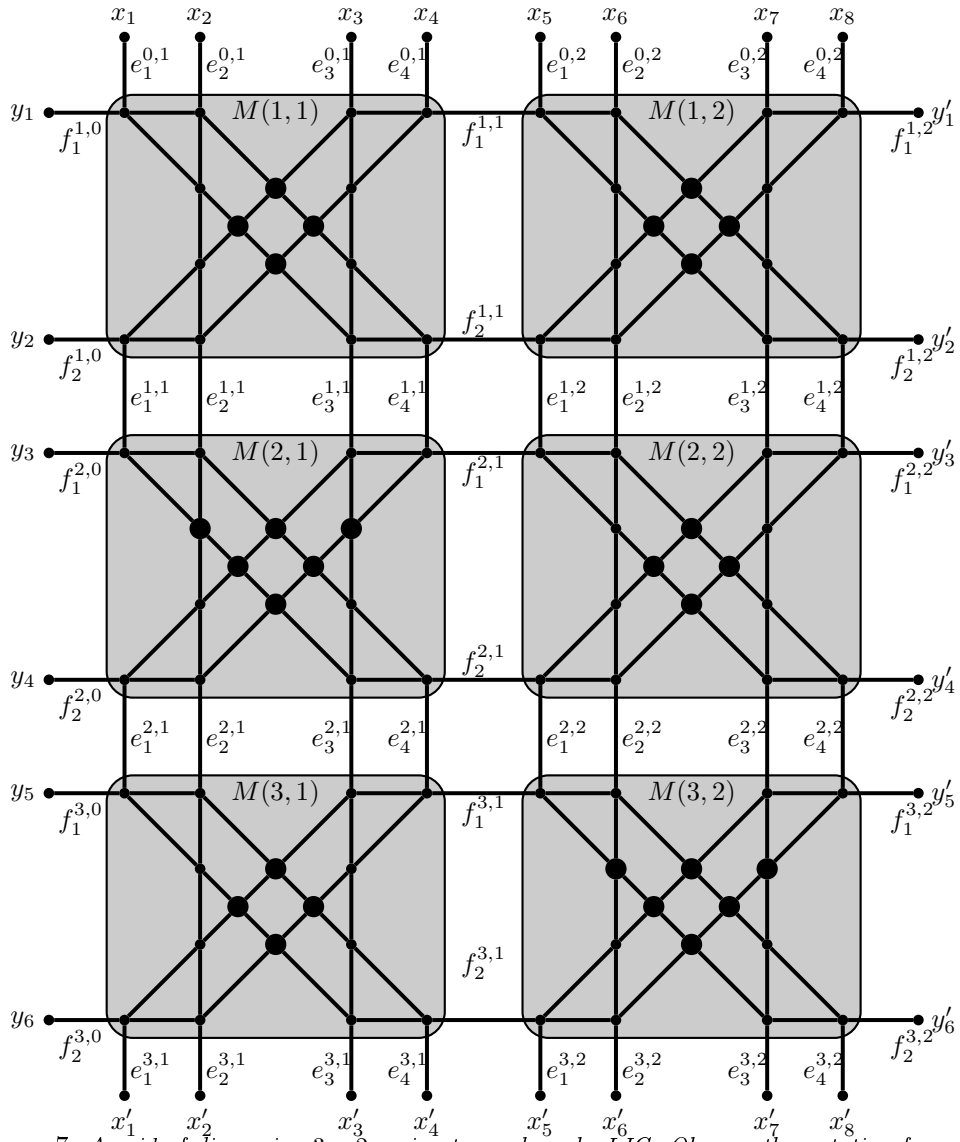

Figure 7: A grid of dimension  $3 \times 2$ , using two subgraphs LIC. Observe the notation for edges between the squares of the grid.

*Proof*

Suppose this path exists. Then, the path  $Q$  between row  $i-1$  and  $i+2$  uses one of the edges  $u_5^{i,j}u_7^{i,j}$  or  $u_6^{i,j}u_8^{i,j}$  for some  $j \in \llbracket 1, n \rrbracket$  and one of the edges  $u_{11}^{(i,j)}u_3^{(i+1,j)}$ ,  $u_{12}^{(i,j)}u_4^{(i+1,j)}$ ,  $u_9^{(i,j+1)}u_1^{(i+1,j+1)}$  and  $u_{10}^{(i,j+1)}u_2^{(i+1,j+1)}$  (if they exist), because all the edges using  $a$ ,  $b$ ,  $c$  or  $d$  of a gadget of rows  $i$  and  $i+1$  are used in  $\mathcal{P}$ . By symmetry,  $u_6^{i,j}u_8^{i,j} \in Q$ . Let  $P_1, P_2, P_3, P_4$  the paths using  $c^{i,j}u_8^{i,j}$ ,  $d^{i,j}u_{11}^{i,j}$ ,  $a^{i+1,j}u_3^{i+1,j}$ ,  $c^{i+1,j}u_6^{i+1,j}$  respectively.  $Q$  and these four paths go through the cut  $C = \{u_8^{i,j}, u_{11}^{i,j}, u_3^{i+1,j}, u_6^{i+1,j}, u_{12}^{i,j}, u_4^{i+1,j}\}$ , but  $d(C) = 8$  and there is no extremity of a path in  $C$ . Thus there are at most 4 distinct paths. Because  $\mathcal{P}$  is uncrossed,  $P_1 \neq P_2$  and  $P_3 \neq P_4$ , and as there is no possible crossing in  $C$ ,  $P_2 = P_3$ . Then,  $P_1, P_2$  and  $P_4$  are parallel, they are crossed by their perpendicular paths in the same order by lemma 7, proving that  $P_1 = P_4$ . Now, we can possibly uncross  $Q$  with  $P_2$  and then with  $P_1$  locally in  $C$ . By shifting  $P_1$  and  $P_2$  to the left, we can suppose that  $u_{11}^{(i,j)}u_3^{(i+1,j)} \in P_2$  and  $u_8^{(i,j)}u_{11}^{(i,j)}, u_{11}^{(i,j)}u_{12}^{(i,j)}, u_{12}^{(i,j)}u_4^{(i+1,j)}, u_4^{(i+1,j)}u_3^{(i+1,j)}$  and  $u_3^{(i+1,j)}u_6^{(i+1,j)}$  all belong to  $P_1$ . This proves that  $i \neq n$  and  $Q$  must go through either  $u_{12}^{(i,j)}u_9^{(i,j+1)}$  or  $u_4^{(i+1,j)}u_1^{(i+1,j+1)}$ . By considering the cut  $D$  defined by  $\{u_7^{(i,j+1)}, u_9^{(i,j+1)}, u_{10}^{(i,j+1)}, u_1^{(i+1,j+1)}, u_2^{(i+1,j+1)}, u_5^{(i+1,j+1)}\}$ , and applying the same arguments as before, we can prove that both edges  $u_9^{(i,j+1)}u_1^{(i+1,j+1)}$  and  $u_{10}^{(i,j+1)}u_2^{(i+1,j+1)}$  are used by  $\mathcal{P}$ . This contradicts the choice of  $j$ .  $\square$

## 4 Hardness of the undirected problem

### Theorem 9

The planar edge-disjoint paths problem is strongly NP-complete, even if the demand graph has only two edges, with terminals lying on the boundary of the infinite face of the graph of offer.

*Proof*

We reduce from 3-SAT : Let  $\mathcal{C} = \{C_1, C_2, \dots, C_n\}$  a set of  $n > 0$  clauses over the set  $\mathcal{X} = \{X_1, X_2, \dots, X_{p'}\}$  of variable. Let  $q = 6n + 2np'$ ,  $q$  will be the number of superfluous crossing nodes. Let  $l = 2q + 3$ ,  $l - 1$  will be the number of rows inserted between each relevant row (see Section 3.2). For each variable, we will have  $2l$  rows in the grid. The first one will encode a *true* value, the  $(l + 1)^{\text{th}}$  will encode a *false* value. The other rows do not own relevant information. Let  $G'$  be a grid of dimension  $p \times n$ , where  $p = 2lp'$ . Note that  $p$  is even.  $M(i, j)$  is a LIC if and only if :

- either there is a  $k \in \llbracket 0, p' - 1 \rrbracket$  such that  $i = 2kl + 1$  and  $x_{k+1}$  appears positively in the clause  $C_j$
- or there is a  $k \in \llbracket 0, p' - 1 \rrbracket$  such that  $i = (2k + 1)l + 1$  and  $x_{k+1}$  appears negatively in the clause  $C_j$

Otherwise, it is a XCH. In this way, there is a LIC exactly where the literal encoded by the row appears in the given column.

We add edges  $x_{4k-1}x_{4k}$  and  $x'_{4k-3}x'_{4k-2}$ ,  $k \in \llbracket 1, n \rrbracket$ , a new node  $x$  (resp.  $x'$ ) with edges to all the vertices of  $X$  (resp.  $X'$ ) that still have degree one. Then we add new vertices  $s, t, w_j, w'_j$ ,  $j \in \llbracket 1, p' \rrbracket$ . Add edges of capacity  $4q + 7$  between  $s$  and the  $w_i$ 's, and between  $t$  and the  $w'_i$ 's. There is an edge between  $w_i$  and  $y_j$  (resp.  $w'_i$  and  $y'_j$ ) for all  $j \in \llbracket 4(i-1)l + 1, 4(i-1)l + 2(l+1) \rrbracket$ , and an edge between  $s$  (resp.  $t$ ) and each vertex of  $Y$  (resp.  $Y'$ ) that still has degree one. Figure 8 gives an idea of the building of the graph  $G$  obtained by this construction, showing the  $2l$  first rows, corresponding to the encoding of variable  $X_1$ . We define the demand graph  $H$  by  $E(H) = \{xx', st\}$ , and the request is  $r(xx') = 2n$ ,  $r(st) = 2p - p'$ . Note that the cuts  $\{x\}$ ,  $\{x'\}$ ,  $\{s\}$  and  $\{t\}$  are tight. Thus, a solution to the edge-disjoint paths problem correspond to a set of horizontal and vertical path in the grid.

The graph  $G$  is obviously planar, the terminals are on the outer boundary. Moreover, the graph have only even-degree vertices except vertices  $w_i$  and  $w'_i$ ,  $i \in \llbracket 1, p' \rrbracket$ , where exactly one edge is not used in a solution as cuts  $\{s\}$  and  $\{t\}$  are tight.

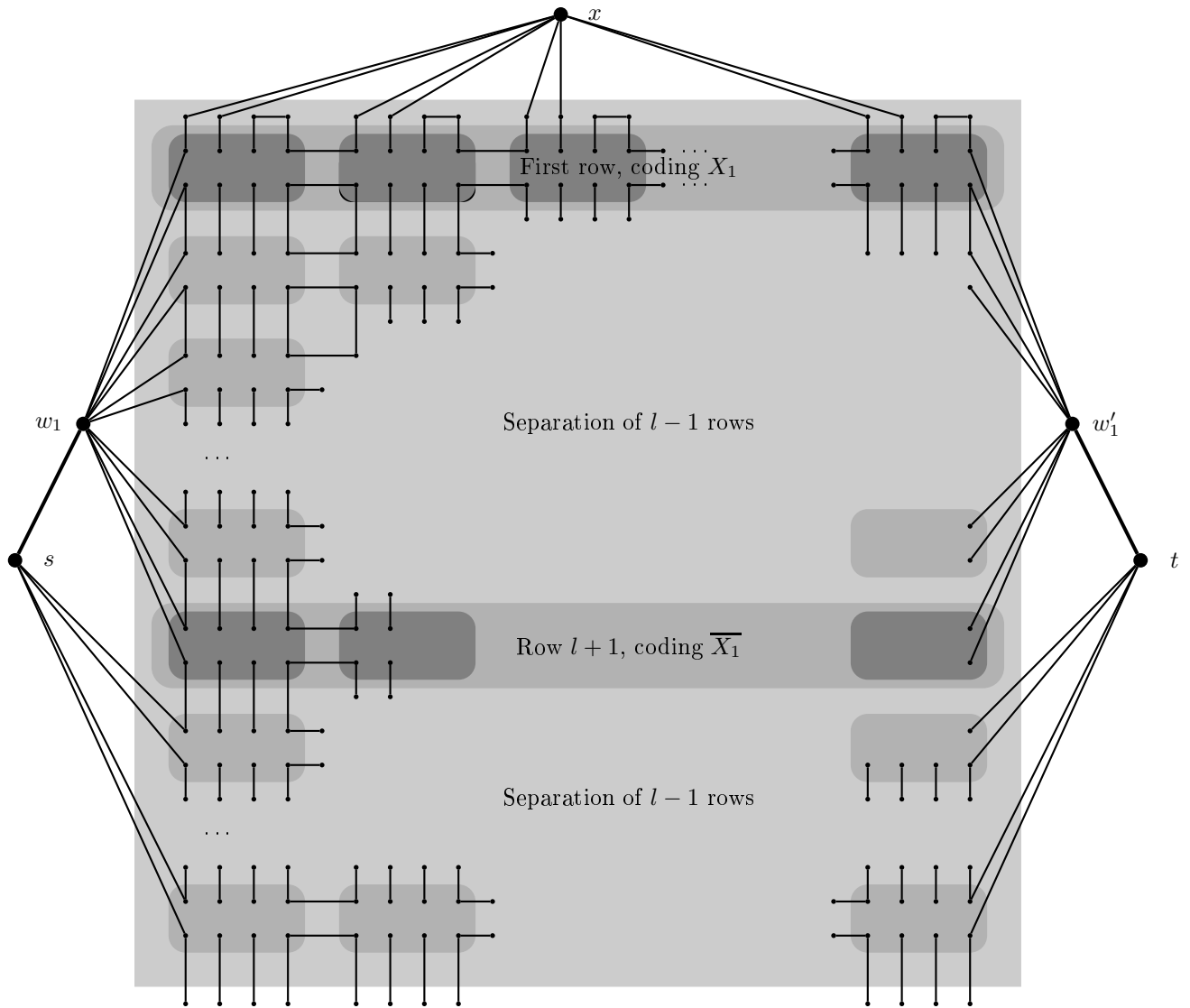

Figure 8: *The upper part of the graph built for the reduction. The first  $2l$  rows are drawn, it corresponds to the encoding of variable  $X_1$ . All squares are XCH except in rows 1 and  $l + 1$ , where there can be LIC subgraphs.*

CLAIM 1

There are exactly  $4np + 6n$  vertices where paths can cross, and  $2n(2p - p')$  are needed. At most  $q = 6n + 2np'$  of these vertices are not used for crossing.

This claim is obvious, as it is sufficient to count the vertices.

CLAIM 2

For all  $i \in \llbracket 0, 2p' - 1 \rrbracket$ , there are two consecutive rows of indices between  $li + 1$  and  $l(i + 1)$ , such that all the crossing vertices are used.

Because of the preceding claim, for a given  $i$ , among these  $2q + 2$  lines, at least  $q + 2$  have all their crossing vertices used, thus two consecutive rows are used.

CLAIM 3

For each solution  $\mathcal{P}$  to the edge-disjoint paths problem, there is a path  $Q_i$  between  $w_i$  and  $w'_i$  in  $G - \mathcal{P}$ .

Because all degrees except those of  $W = \{w_i, w'_i : i \in \llbracket 1, p' \rrbracket\}$  are even in  $G + H$ , the complementary of the paths of the solution has even degree, except in these vertices. Thus, there is a  $W$ -join, *i.e.* a set of paths with disjoint extremities covering  $W$  in  $G - \mathcal{P}$ . But as the  $w_i$ 's are separated by two full consecutive rows by claim 1 and Lemma 8, and the same is true for the  $w'_i$ 's, these paths are all  $(w_i, w'_i)$ -paths, for all  $i \in \llbracket 1, p' \rrbracket$ .

CLAIM 4

No vertical path uses an edge of type  $f_k^{i,j}$ . All these edges are used either by a horizontal path, or by some  $Q_h$ ,  $h \in \llbracket 1, p' \rrbracket$

Let  $V_j = \{f_1^{i,j}, f_2^{i,j} : i \in \llbracket 0, p \rrbracket\}$  for all  $j \in \llbracket 0, n \rrbracket$ . When deleting vertices  $x$  and  $x'$  (remember that  $\{x\}$  and  $\{x'\}$  are tight cuts),  $V_j$  defines a cut, with  $2p - p'$  demand edges going through this cut. Counting the  $p'$  paths in  $G - \mathcal{P}$  going through  $V_j$ , there is no remaining edge for a vertical path to use it.

CLAIM 5

Let  $i \in \llbracket 1, p \rrbracket$ ,  $j \in \llbracket 1, n \rrbracket$ ,  $k \in \{1, 2\}$ , suppose  $f_k^{i,j}$  is not used by a path of  $\mathcal{P}$ . Then, one of the edges of  $\{f_a^{i+\epsilon, j+1} : \epsilon \in \llbracket -2, 2 \rrbracket, a \in \{a, b\}\}$  is not used by  $\mathcal{P}$ .

Because of the previous claim, the cuts  $V_j$  and  $V_{j+1}$  are “tight”. Moreover, the horizontal paths go through this cut in the same order from top to bottom, because the paths are uncrossed. Suppose the claim is false, and take a minimal  $j$  and then a minimal  $i$ , such that  $f_k^{(i,j)}$  belongs to some  $Q_h$ ,  $h \in \llbracket 1, q' \rrbracket$  and contradicting the claim. There is one edge  $f_{k'}^{(i', j+1)}$  in  $V_{j+1}$  that belongs to  $Q$ . W.l.o.g. we suppose  $i' > i$  (the other case is symmetric). Moreover, we know by the minimality of  $j$  that  $i < (2h - 1)l + 1 + 2j$  (the path  $Q_j$  can not move over more than two rows in each column) and that the edge in  $Q_{h+1} \cap V_j$  is in a row of index at least  $2hl + 1 - 2j > i + 2$  (because  $4j + 2 < 4n + 2 < q$ ). Thus we only have to show that the edge-disjoint path problem described in figure 9 has no solution (two identical letters defines the terminals of a demand edge), where  $Q$  is a special path that can cross other paths in every node.

Thick edges are the edges that belong to a tight cut. We use three LIC graphs, as they are more general than XCH graphs. They are called  $L_1, L_2, L_3$  from top to bottom. Suppose that there exists a solution, we name the paths with the letters of their demand edges. We can suppose that all the paths except  $Q$  are uncrossed, and  $A$  is to the left of  $B$ . Because of tight cuts,  $E$  is contained in  $L_2$  and  $G$  in  $L_3$ , and  $F$  do not use any of the thick edges in the bottom-left corner of  $L_3$  or in the top-right corner of  $L_2$ . Because the solution is uncrossed,  $E, F$  and  $G$  do not cross each other.  $E$  must use  $u_6$  in  $L_2$ , because either it goes through  $u_4u_6$ , or through  $u_4u_3$  but then can not cross the other path going through  $u_3$  (which is not  $Q$  as it goes through  $u_4$ ), and then  $E$  uses  $u_3u_6$ . Moreover,  $E$  uses one of the three following edges :  $u_5u_7, bu_7, du_{10}$  in  $L_2$ . It proves that the vertices  $a, c$ , and  $u_5$  are “above” (see figure 9) or in the path  $E$ , that is  $F$  can use neither  $u_5$  nor  $a$ , and can not cross anything at  $b$  or  $c$ . Thus  $d$  is the only possible node for a crossing between  $F$  and either  $A$  or  $B$  in  $L_2$ . We use the same argument in  $L_3$  with  $F$  and  $G$ , proving that the only

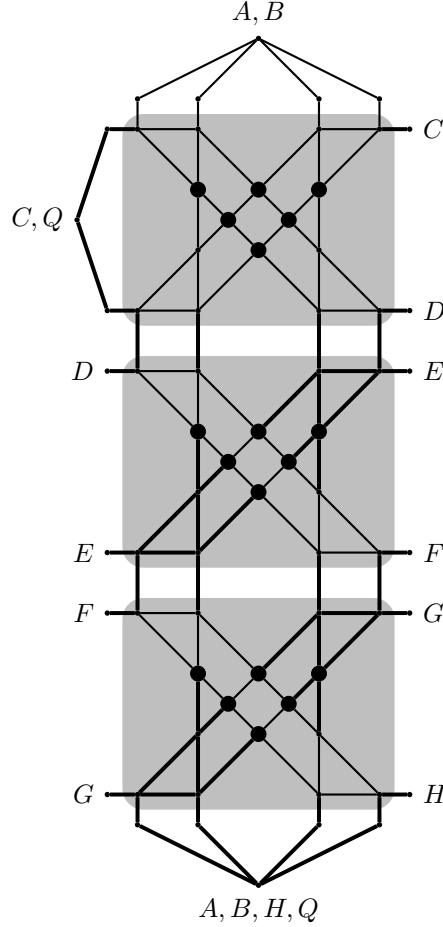

Figure 9: *Claim 5 is reduced to the proof of non-existence of a solution to the multiflow problem presented in this figure. Demands link vertices with same label. Thick edges belong to tight cuts.*

possible nodes for crossing between  $F$  and  $A$  or  $B$  are  $u_5$  and  $a$ . But if there was such a crossing at  $u_5$ , then the other path,  $A$  or  $B$ , would go through  $u_5u_7$ , and then because of tight cuts, would never cross  $G$  in  $L_3$ , which is impossible. Eventually,  $F$  crosses  $A$  and  $B$  at vertices  $a$  in  $L_3$  and  $d$  in  $L_2$  respectively. If  $F$  goes through one of the left-most edges between  $L_2$  and  $L_3$ , then it goes through both  $u_2a$  and  $u_5b$  in  $L_3$ , otherwise it goes through  $du_{11}$  and  $cu_8$  in  $L_2$ . In the first case, it goes through  $bd$  of  $L_3$ , and in the second case through  $bc$  and  $ad$  of  $L_2$ . This contradicts the existence of  $G$  or  $E$  respectively.

#### CLAIM 6

There is no solution to the edge-disjoint path problem depicted in figure 10, with a demand of 5 for the  $S$  terminals

Suppose that these paths exist. We distinguish two special cuts  $L$  and  $R$ . There are exactly 12 vertices for crossings, and 10 are needed. The  $S$ -paths use 5 edges of  $\delta(L)$  and 5 of  $\delta(R)$ . The  $A$ -path and the  $B$ -path both use an even number of edges in these two coboundaries (because they have their extremities in the same parts of the cuts). Moreover, they can do at most 2 crossings in each of the three groups of four crossing nodes (corresponding to the crossing vertices of a XCH graph), thus they go through each of these groups. Then each uses at least 6 edges in the two coboundaries, and because of parity, the  $A$ -path uses 4 edges of  $\delta(L)$  and 2 of  $\delta(R)$ , and the  $B$ -path uses 2 edges of  $\delta(L)$  and 4 edges of  $\delta(R)$ . Because  $d(L) = d(R) = 12$ , there can not be more. Thus, each  $S$ -path uses exactly one edge of  $\delta(R)$ , and one of  $\delta(L)$ . Then, in the central XCH graph, there are exactly one edge of the  $\delta(L)$  and one edge of  $\delta(R)$  used by the  $A$ -path, and two edges of  $\delta(R)$  used by the  $B$ -path. At least two edges of  $\delta(L)$  must be used by the  $S$ -paths, and at most one of  $\delta(R)$ . But this leads to a contradiction, as each  $S$ -path can not use more than one edge in each

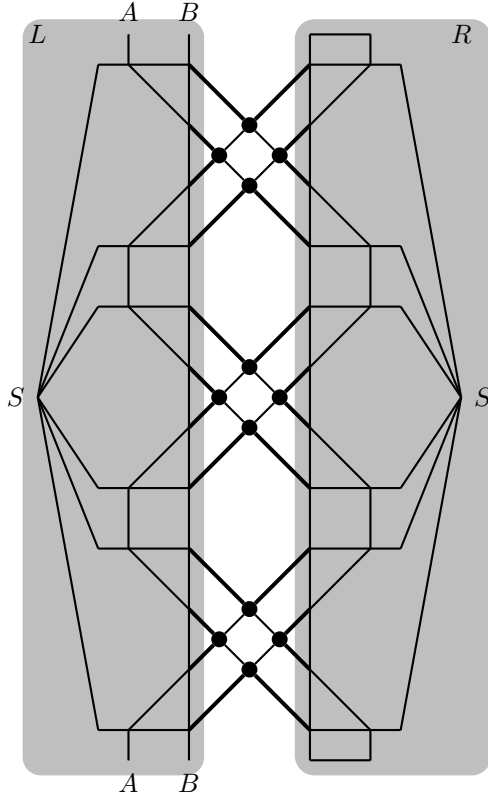

Figure 10: *Claim 6* proves the non-existence of a solution to the multiflow problem presented in this figure. The demand between the  $S$  terminals is 5.

coboundary of the two cuts.

#### CLAIM 7

If there exists a solution  $\mathcal{P}$  to the edge-disjoint paths problem, then the formula is satisfiable.

For each  $i \in \llbracket 1, p' \rrbracket$ , assign the value *true* to  $X_i$  if  $Q_i$  goes through rows  $2(i-1)l+3$  or less, *false* otherwise, in particular when  $Q_i$  goes through rows  $(2i-1)l-1$  or more. Note that  $Q_i$  can not go through these two rows, as there are  $l-5 > 2n$  rows between them, and claim 5 ensures that  $Q_i$  can not move of more than two rows by column. We prove that this assignment satisfies the original formula, by proving that each clause is satisfied.

Let  $j \in \llbracket 1, n \rrbracket$  be the index of a column. We know that there are  $p-p'$  paths going from left to right in this column, and  $p'$  paths  $Q_1, \dots, Q_{p'}$  in the complement of the solution. Because of the propositions of section 3.3, for each  $i \in \llbracket 1, p \rrbracket$ , the two vertical paths goes through  $e_1^{i-1,j}, e_3^{i,j}$  and  $e_2^{i-1,j}, e_4^{i,j}$  respectively, or through  $e_3^{i-1,j}, e_1^{i,j}$  and  $e_4^{i-1,j}, e_2^{i,j}$  (\*), except when :

- (i) either  $M(i, j)$  is a LIC,
- (ii) or there is some  $k \in \llbracket 1, q' \rrbracket$  such that  $Q_k$  goes through  $M(i', j)$  with  $|i' - i| < 2$ .

If only (i) is realized, then  $M(i-1, j)$  and  $M(i+1, j)$  (if exists) are XCH and no paths in the complementary graph goes through them. In that case, we can apply proposition 6 to prove (\*). If (ii) is satisfied, suppose that  $Q_k$  goes exactly through  $M(i_1, j)$  to  $M(i_2, j)$ , and that  $M(i_1+h, j)$  is a XCH for each  $h \in \llbracket -1, 3 \rrbracket$ . Then, we apply proposition 3 to  $M(i_1-1, j)$  and  $M(i_1+3, j)$  and then claim 6 to the three consecutive squares  $M(i_1, j)$  to  $M(i_1+2, j)$ . It proves that the two vertical paths of column  $j$  uses either edges  $e_1^{i_1-2,j}, e_3^{i_1+3,j}$  and  $e_2^{i_1-2,j}, e_4^{i_1+3,j}$ . In all this distinct cases, the two vertical paths are globally forced to alternate between left-hand side and right-hand side of the column. But there is an even number of row, and the paths enter the column in the top-left and bottom-right corner. Thus the alternation must be broken somewhere. Consequently there is a row in the column where both (i) and (ii) are true. Then, there is a LIC in the column near a path of the complement, that is the literal encoded by this LIC is satisfied by the chosen

assignment, proving the clause is also satisfied. Because this is true for each possible  $j$ , the formula is satisfied, thus satisfiable.

CLAIM 8

If the formula is satisfiable, then there is a solution to the edge-disjoint paths problem.

Because of the property of the graphs XCH and LIC. We can suppose that we choose to take the  $(w_i, w'_i)$ -paths of the complementary in a single row, either the row  $2(i-1)l+1$  if  $X_i$  is positive, or  $(2i-1)l+1$  if  $X_i$  is negative. Then, the two vertical paths for each clause can stay in the same side of their column when they cross the  $(w_i, w'_i)$ -path where  $X_i$  is the variable satisfying this clause. Properties of gadgets ensure this construction is correct.  $\square$

## 5 Directed case

Using the classical gadget (see figure 11) that allows to use undirected edges in digraph when considering arc-disjoint paths problems, we have the following result as an obvious consequence of theorem 9.



Figure 11: We can replace every undirected edge in this way. Thus the complexity of the multiflow problem in digraphs do not change if we allow undirected edges.

### Corollary 10

The arc-disjoint paths problem is strongly NP-complete, even if the offer graph is planar, the demand graph has only two arcs and the terminals lie on the boundary of the infinite face of  $G$ .

We can do a little better.

### Corollary 11

The planar arc-disjoint path problem is NP-complete, even if the offer graph is planar, the demand graph  $G$  has only two terminals  $s$  and  $t$  lying on the infinite face of  $G$ , and with only two demands for  $st$  (but possibly many demands for  $ts$ ).

*Proof*

We slightly modify the reduction of the proof of theorem 9. First, we delete  $x$  and  $x'$ . We orient the edges of each vertical cut from right to left. We suppose without loss of generality that  $n$  is odd. For all  $i \in \llbracket 1, (n-1)/2 \rrbracket$ , we add the following arcs :  $(x_{8i-3}, x_{8i+2})$ ,  $(x_{8i-2}, x_{8i+1})$ , and for all  $i \in \llbracket 1, (n-1)/2 \rrbracket$ ,  $(x'_{8i-5}, x'_{8i})$  and  $(x'_{8i-4}, x'_{8i-1})$ . Then we had two new nodes  $s'$  and  $t'$ . There are an arc from  $t'$  to  $t$  with multiplicity  $2p' - p$ , and arcs  $(x'_{4n}, t')$ ,  $(x'_{4n-1}, t')$ , plus an arc from  $s$  to  $s'$  with multiplicity  $2p - p'$ , and arcs  $(s', x_1)$  and  $(s', x_2)$ . The demand are 2 from  $s'$  to  $t'$ , and  $2p - p'$  from  $t'$  to  $s'$ .

The reduction is correct, as the two  $(s', t')$ -paths must take the role of the vertical paths, because they must use the new edges between vertices of  $X$  and of  $X'$  (they belong to tight cuts).  $\square$

## 6 Directed Acyclic case

In this section, we do not use anymore the notion of non-cross nodes. We use again the grids of subgraphs, but with different subgraphs, to prove the following theorem:

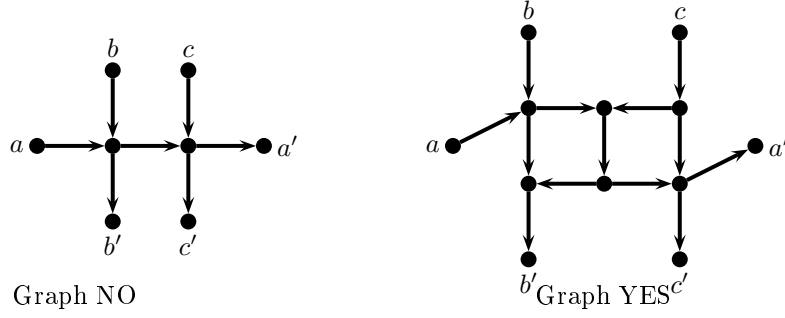

Figure 12: In NO, there is no path from  $c$  to  $b'$ , whereas it is possible in YES, as long as no other path goes through the graph.

**Theorem 12**

The planar arc-disjoint paths problem is NP-complete, even if  $G$  is acyclic and  $H$  consists of two sets of parallel edges.

*Proof*

We reduce from SATISFIABILITY. Let  $C_1 \wedge \dots \wedge C_n$  be a formula with  $n$  clauses, over the set of variables  $\{X_1, \dots, X_p\}$ . Let  $G_1$  be a grid with  $n$  columns and  $2p$  rows, where each point  $G_1(i, j), i \in \llbracket 1, 2p \rrbracket, j \in \llbracket 1, n \rrbracket$  of the grid is a special subgraph, defined as follows (see figure 12):

- $G_1(2i - 1, j)$  is the graph YES if  $X_i$  appears positively in  $C_j$ ,
- $G_1(2i, j)$  is the graph YES if  $X_i$  appears negatively in  $C_j$ ,
- $G_1(i, j)$  is NO in all other cases.

We identify vertex  $a'$  of  $G_1(i, j)$  with  $a$  of  $G_1(i, j + 1)$ , and vertices  $b'$  and  $c'$  of  $G_1(i, j)$  with  $b$  and  $c$  respectively of  $G_1(i + 1, j)$  for all possible values of  $i$  and  $j$ . We call row  $i$  the subgraph  $\text{row}(i)$  induced by vertices of  $G_1(i, j), j \in \llbracket 1, n \rrbracket$ , and column  $j$  the subgraph  $\text{col}(j)$  induced by vertices of  $G_1(i, j), i \in \llbracket 1, 2p \rrbracket$ . The  $k^{\text{th}}$  vertical cut is defined by  $\delta(\bigcup_{i \in \llbracket 1, k \rrbracket} \text{row}(i))$ , and the  $k^{\text{th}}$  horizontal cut is defined by  $\delta(\bigcup_{j \in \llbracket 1, k \rrbracket} \text{col}(j))$ .

CLAIM 1

The formula is satisfiable if and only if there is a set  $\mathcal{P}$  of arc-disjoint paths in  $G_1$  such that :

- (i) for each  $j \in \llbracket 1, n \rrbracket$ , there is a path  $P_j$  in  $\mathcal{P}$  from  $c \in G_1(1, j)$  to  $b' \in G_1(2p, j)$ ,
- (ii) for each  $i \in \llbracket 1, p \rrbracket$ , there is a path  $Q_i$  in  $\mathcal{P}$  either from  $a \in G_1(2i - 1, 1)$  to  $a' \in G_1(2i - 1, n)$  or from  $a \in G_1(2i, 1)$  to  $a' \in G_1(2i, n)$ .

Suppose that  $\mathcal{P}$  exists. For all  $i \in \llbracket 1, p \rrbracket$ , if  $Q_i$  has extremities  $a \in G_1(2i - 1, 1)$  and  $a' \in G_1(2i - 1, n)$ , then assign value *false* to  $X_i$ , otherwise assign value *true*. For all  $j \in \llbracket 1, n \rrbracket$ , the  $j^{\text{th}}$  horizontal cut is a directed cut, thus every path  $Q_i, (i \in \llbracket 1, p \rrbracket)$  is contained in a single row. Similarly, every path  $P_j, j \in \llbracket 1, n \rrbracket$  is contained in a single column. For each path  $P_j, j \in \llbracket 1, n \rrbracket$ , let  $i$  be the index of the first row where  $P_j$  goes through  $c' \in G_1(i, j)$ . Then  $P_j$  is the only path that goes through  $G_1(i, j)$ , and  $G_1(i, j)$  is a YES graph. If  $i$  is even, it means that  $X_{\frac{i}{2}}$  appears negatively in  $C_j$  and this variable has value *false*, thus  $C_j$  is satisfied. Otherwise  $X_{\frac{i+1}{2}}$  appears positively in  $C_j$  and this variable has value *true*, thus  $C_j$  is also satisfied. Then the formula is satisfied. The converse is obvious.

We just have to enforce paths to be as required in previous claim. Condition (i) is easy to satisfy. To verify condition (ii) we need some gadgets, depicted in figure 13.

CLAIM 2

Let  $P_1$  be a path between  $a$  and one of  $a_i, i \in \{1, 2\}$ , and  $P_2$  be a path between  $b$  and  $b_j, j \in \{1, 2\}$ , in IF, LL or TT. If  $P_1$  and  $P_2$  are arc-disjoint, then  $i = j$ .



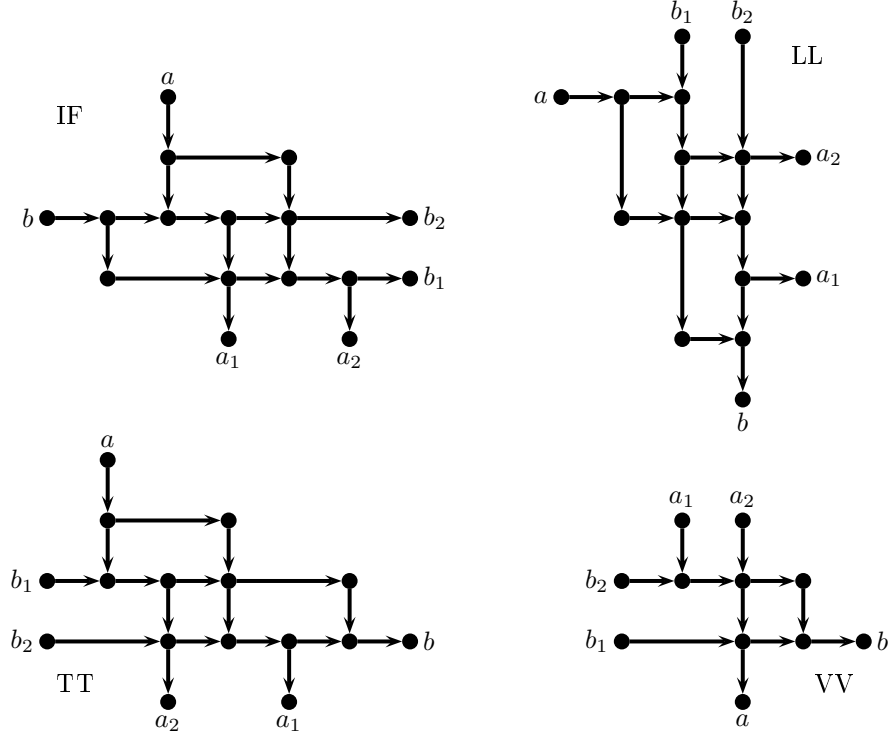

Figure 13: *Four special subgraphs, from top to bottom and left to right : IF, LL, TT, VV. First three have the property that if there are two arc-disjoint paths, one between  $a$  and  $a_i$  and the other between  $b$  and  $b_j$ , then  $i = j$ .*

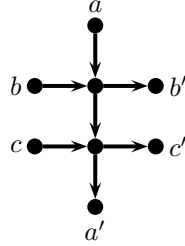

Figure 14: *Graph ON, it has the same property as graph NO.*

CLAIM 3

There are not two arc-disjoint paths in VV, one from  $b_2$  to  $b$  and the other from  $a_1$  to  $a$ .

Claim 2 and Claim 3 can be readily checked. We will also need the graph ON introduced in figure 14. We now describe the full graph for the reduction.  $G$  is built from  $G_1$  in the model of figure 15.  $G$  is built from a grid with  $2p+n$  columns and  $2p$  rows. The subgrid defined by columns  $p+1$  to  $p+n$  and rows 1 to  $p$  is  $G_1$ . Note that two rows in  $G_1$  correspond to one row in  $G$ . Squares  $G(i, i)$ ,  $G(p+1-i, n+p+i)$ ,  $G(2p+1-i, i)$  and  $G(p+i, n+p+i)$ , for all  $i \in \llbracket 1, p \rrbracket$ , are special graphs IF, TT, LL and VV respectively. Others are either NO or ON, according to the figure. We identify vertices of degree one of adjacent gadgets, as in the construction of  $G_1$ . Rows, columns, vertical cuts and horizontal cuts are defined in the same way as for  $G_1$ . We add four terminals, one for each side of the grid (see the figure).

We had a demand of  $2p$  from  $s_1$  to  $s_2$ , and  $2p+n$  from  $t_1$  to  $t_2$ .

CLAIM 4

$G$  is acyclic.

Observe that in the grid, all arcs are from left to right or downward, and the special graphs are all acyclic.

CLAIM 5

There is exactly one path going from top to bottom in each column of  $G$ , this path never leaves

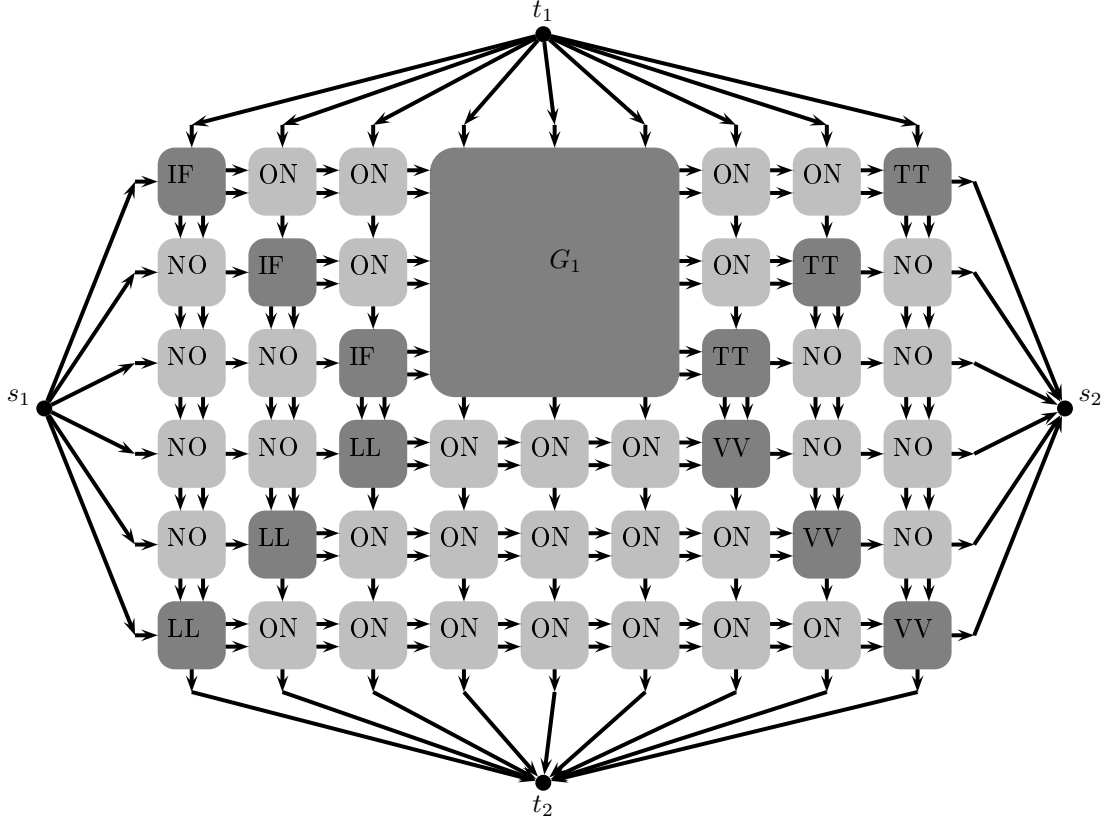

Figure 15: *The graph for the reduction with a formula containing three clauses over three variables.*

the column. There is exactly one path going from left to right in each row of  $G$ , this path never leaves the row.

Because vertical and horizontal cuts are directed, and  $\{s_1\}$ ,  $\{s_2\}$ ,  $\{t_1\}$ ,  $\{t_2\}$  are tight cuts.

CLAIM 6

If a horizontal path leaves  $G_1$  by the lower edge of its row in the  $n + p^{\text{th}}$  vertical cut, then the same path enters  $G_1$  by the lower edge of its row in the  $p^{\text{th}}$  vertical cut.

In each square ON or NO, there is exactly one path from  $b$  to  $b'$  or from  $c$  to  $c'$ , and one path from  $a$  to  $a'$ , because of properties of these gadgets. Consequently, a vertical path leaves an IF gadget by the left if and only if it enters the LL gadget of the same column by the left. Similarly for paths between LL and VV, for paths between TT and VV, for paths between IF and  $G_1$  and for paths between  $G_1$  and TT. If a path leaves  $G_1$  by the lower edges of its row, say row  $i \in \llbracket 1, p \rrbracket$ , then it enters  $G(i, 2p + n + 1 - i)$  by vertex  $b_2$ . The vertical path of column  $2p + n + 1 - i$  leaves  $G(i, 2p + n + 1 - i)$  by vertex  $a_2$  by claim 2, and then enters  $G(p + i, 2n + p + 1 - i)$  by vertex  $a_1$ . Thus the horizontal path in row  $p + i$  goes in  $G(p + i, 2n + p + 1 - i)$  using vertex  $b_1$  by claim 3, and leaves  $G(p + i, 2p + 1 - i)$  by vertex  $a_1$ . Using claim 2, the vertical path in column  $i$  go in  $G(p + i, 2p + 1 - i)$  by vertex  $b_1$ , thus go out  $G(i, i)$  by vertex  $a_1$ . By claim 2 again, the horizontal path of row  $i$  leaves  $G(i, i)$  by  $b_1$ , and then enters  $G_1$  by the lower edge, proving the claim.

CLAIM 7

There is a solution to the arc-disjoint path problem in  $G$  if and only if the formula is satisfiable.

Claim 6 proves that the path in  $G_1$  satisfies the condition (ii) of claim 1: if there is a solution to the arc disjoint path problem, the formula is satisfiable. The converse is also true, it is sufficient to extend the solution for  $G_1$  naturally.

As the construction is obviously polynomial, we found a Karp reduction between the two problems. The arc-disjoint paths problem being in NP, the theorem is proved.  $\square$

We now strengthen Corollary 11

### Corollary 13

The arc-disjoint paths problem in planar graphs is NP-complete, even if the demand graph has only two arcs, with one of request 1 (one flow plus one path).

#### *Proof*

We modify the preceding reduction, in the same way as in the proof of Corollary 11. We remove  $t_1$  and  $t_2$ , and add arcs from the bottom of a column, to the top of the next column to the left. This preserves planarity. Then we add a demand arc from the bottom of the leftmost column to the top of the rightmost column, with demand 1. We keep the arc  $s_2t_2$ . The new demand must be routed through the new arcs because of the vertical tight cuts. Thus, this transformation preserves the property of the original reduction.  $\square$

There are still some open problems in this field, in particular, what happens in digraphs when the total amount of demand is fixed, and as a special case, can we find a cycle in a planar digraph, that goes through two specified vertices ? This last problem is mentioned in [9].

## References

- [1] A. FRANK, *Edge-disjoint paths in planar graphs*, Journal of Combinatorial Theory B 39 (1985), 164-178.
- [2] A. FRANK, *Packing paths, circuits and cuts - a survey*, in : Paths, Flows, and VLSI-Layout (B.Korte, L.Lovász, H.J. Prömel, A. Schrijver, eds.), Springer, Berlin (1990), 47-100
- [3] M.R. KRAMER, J. VAN LEEUWEN, *The Complexity of Wire-Routing and Finding the Minimum Area Layouts for Arbitrary VLSI Circuits*, in: F.P. Preparata : *Advances in Computing Research 2 : VLSI Theory*, JAI press, London (1984), 129-146.
- [4] K. MENGER, *Zur allgemeinen Kurventheorie*, Fundamenta Mathematicae 10 (1927), 96-115.
- [5] D. MÜLLER, *On the complexity of the planar directed edge-disjoint paths problem*, Mathematical Programming, vol. 105, No.2-3 (2006), 275-288.
- [6] H. OKAMURA, P.D. SEYMOUR., *Multicommodity flows in planar graphs*, Journal of Combinatorial Theory B 31 (1981), 75-81.
- [7] H. OKAMURA, *Multicommodity flows in graphs*, Discrete Applied Mathematics 6 (1983), 55-62.
- [8] N. ROBERTSON, P.D. SEYMOUR, *Graph Minors XIII. The Disjoint Paths Problem*, Journal of Combinatorial Theory B 63 (1995), 65-110.
- [9] A. SCHRIJVER, *Combinatorial Optimization : Polyhedra and Efficiency*, Springer (2003).
- [10] W. SCHWARZLER, *On the complexity of the planar edge-disjoint paths problem with terminals on the outer boundary*, accepted in Combinatorica.