



HAL
open science

Dependability and analytical redundancy

Didier Maquin, Marie Luong, Jean-Marc Paris

► **To cite this version:**

Didier Maquin, Marie Luong, Jean-Marc Paris. Dependability and analytical redundancy. On-line Fault Detection and Supervision in the Chemical Process Industries, Jun 1995, Newcastle upon Tyne, United Kingdom. pp.188-193. hal-00310530

HAL Id: hal-00310530

<https://hal.science/hal-00310530>

Submitted on 6 May 2014

HAL is a multi-disciplinary open access archive for the deposit and dissemination of scientific research documents, whether they are published or not. The documents may come from teaching and research institutions in France or abroad, or from public or private research centers.

L'archive ouverte pluridisciplinaire **HAL**, est destinée au dépôt et à la diffusion de documents scientifiques de niveau recherche, publiés ou non, émanant des établissements d'enseignement et de recherche français ou étrangers, des laboratoires publics ou privés.

DEPENDABILITY AND ANALYTICAL REDUNDANCY

Didier Maquin, Marie Luong, Jean-Marc Paris

*Centre de Recherche en Automatique de Nancy - CNRS UA 821
Institut National Polytechnique de Lorraine
2, Avenue de la Forêt de Haye - 54516 Vandoeuvre Cedex
Phone: +33 83 59 56 83 Fax: +33 83 59 56 44
Email: {dmaquin, mluong, jmparis}@ensem.u-nancy.fr*

Abstract: The quality of the state estimation of a system and, consequently, its dependability are strongly conditioned by the number and the location of the measurements. So, the measurement planning represents a very important stage. This communication presents a method for assessing the availability of the necessary information for the process control and defining the sensor locations such that the variables required for controlling the process remain always observable even if one or more sensors become defective.

Key Words: Sensor placement, Redundancy, Dependability, Diagnosis

1. INTRODUCTION

The availability of a system may be increased if this latter is able to function even in the presence of sensor breakdowns. So, the measurement planning (measurement system design) represents a very important stage. The problem of designing a measurement system is not new, though, in many previous works, the optimisation aspect is not explicitly discussed. In fact, measurement placement is closely connected with the problem of variable classification into observable and unobservable quantities. All variables that can be estimated through their measurements or indirectly through some relationships with other measured variables are defined as observable. Moreover, if a measured variable can also be indirectly estimated by using measurements of other variables, then it is termed as redundant.

Studying the observability of a system consists in answering the question: can the value of the variables of a system from a given set of measurements be determined? If the process is non observable, observable and non observable parts may however be determined. As we can quite imagine, the state estimation of a system is possible only if some conditions are satisfied and especially requires to have a minimum amount of information that is to say a minimum amount of sensors; these sensors have to

be judiciously placed in order to give an “image” of the totality of the process. Moreover, it is necessary to consider the realistic case in which initially provided sensors can fail. Consequently to these failures, the control of a process can be performed only if variables measured by these faulty sensors can be estimated. Considering these remarks, one can assert that the choice of the instrumentation (number, position and characteristics of sensors) is a crucial problem. In the following, our purpose is limited to the study of systems described by linear equations (for example, they can correspond to equations of matter or energy conservation).

Many works on observability analysis of steady-state linear systems have already been published. Among the firsts of them, those of Vaclavek *et al.*, (1969) may be mentioned; afterwards, Stanley and Mah (1981) and Crowe *et al.* (1983) have largely contributed to develop this analysis. Algorithms of observability that have been proposed are generally based on graph theory (Mah *et al.*, 1976) or on a classification of variables from a projection matrix (Crowe, 1989), (Ragot *et al.*, 1990).

After the analysis phase, making in evidence not only redundancy but also the possible weaknesses of the measurement system, it is advisable to propose modifications of the existent sensor placements or

even sensor addition. These modifications are studied considering precise objectives: to render observable a particular variable, to increase the degree of redundancy of another one, to enhance the precision of the estimation of a particularly useful variable for the control of the process, to tolerate sensor failures (Maquin *et al.*, 1994). At present, there are only few works dealing with the design of a measurement system satisfying the previous constraints. Madron *et al.* (1992) proposed a solution based on the analysis of the incidence matrix of the graph describing the process. Immonen (1994) formulated the problem as a linear programming one. The resulting optimisation problem is solved using a mixed integer programming method in order to take into account the occurrences and locations of sensors. The most developed works are undoubtedly those presented by Ali *et al.* (1993) and Luong *et al.* (1994). Based on the analysis of the cycles of the process graph, these studies simultaneously take into account the variable observability and the reliability of the sensors in order to determine an optimal measurement system with regard to certain criteria.

This paper is organised as follows. In the second section, the process codification is described. The third section is dedicated to the presentation of the different problems via an intuitive approach. The notion of multiple redundancy (degree of redundancy) which allows sensor failures or breakdowns to be tolerated without being prejudicial to the control of the process is presented and formalised. Then the problem of sensor location is approached. Some definitions, principles and rules are also described in this section. In the fourth section, the previous notions are generalised in a systematic approach. Some algorithms are described and methods for designing a measurement system guaranteeing the degree of redundancy of certain variables whilst minimising the installation cost of the sensors are presented.

2. PROCESS CODIFICATION

Here, we consider only processes which may be described by a carriage network (figure 1), the nodes (processing units) of which correspond to elementary equations and the arcs (material or energy transfer stream) to variables.

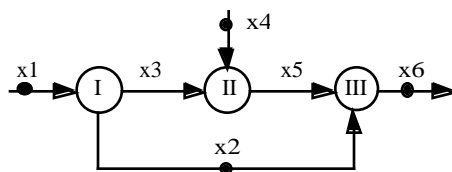

Figure 1: a carriage network

The associated graph is obtained by adding a so-called "environment node" to which all the input/output are linked on. In order to simplify the figures, this node has not been drawn. The corresponding equation is obtained by adding all the other equations. Such process may be described by a set of linear equations:

$$\mathbf{x1} - \mathbf{x2} - \mathbf{x3} = 0 \quad (1a)$$

$$\mathbf{x3} + \mathbf{x4} - \mathbf{x5} = 0 \quad (1b)$$

$$\mathbf{x2} + \mathbf{x5} - \mathbf{x6} = 0 \quad (1c)$$

The process is equipped with sensors measuring different flow variables. They are represented by a point on the figures and are written in **boldface** in the equations. The preceding set of linear equations may also be written using a matricial form by defining the following vector $X = (x1 \ x2 \ x3 \ x4 \ x5 \ x6)^T$. The four equations are then written $M X = 0$, where M is the so-called incidence matrix which contains only 1, 0 and -1 elements.

3. INTUITIVE APPROACH - DEFINITIONS

3.1 Observability

The variable classification based on the observability analysis consists in pointing out two categories of variables: the observable variables, the value of which may be known (by direct measurement or by deduction from other measurements) and the unobservable variables. Taking into account the small dimensions of the proposed example, this analysis may be done intuitively. The addition of the equations (1a), (1b) and (1c) allow a redundancy equation to be extracted: $\mathbf{x1} + \mathbf{x4} - \mathbf{x6} = 0$. Such equation involves measured variables only. The equations (1a) and (1c) are equations of deduction; they allow unmeasured variables $x3$ and $x5$ to be deduced. This analysis leads to the classification of the variables into the four following distinct categories:

$$L_{me} = \{x1, x4, x6\} \quad L_{\bar{m}\bar{e}} = \{x2\}$$

$$L_{\bar{m}e} = \{x3, x5\} \quad L_{\bar{m}\bar{e}} = \emptyset$$

The first subscript (m or \bar{m}) indicates whether a variable is measured or unmeasured and the second one (e or \bar{e}) whether it is estimable or non estimable. From this notion of observability, one can now define that of degree of redundancy which will be very useful when taking into account sensor breakdowns.

3.2 Minimal observability of a variable

An observable variable is redundant of degree 0 (minimal observability) if there exists, at least, a configuration such that the breakdown of only one sensor make this variable inaccessible. For example, it is the case of the measured but non estimable variables. Some unmeasured variables may also own this property. Let us consider the network of figure 2 where measurements are indicated by a point.

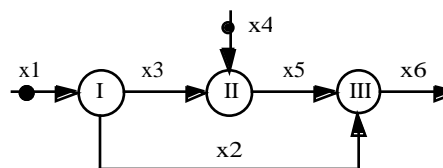

Figure 2: network number 1

The variable x_6 may be deduced from the equation issued from the “aggregation” of nodes I, II and III: $x_1 + x_4 - x_6 = 0$. In a normal situation, when measurements of x_1 and x_4 are available, the variable x_6 is deducible. But, when one of the sensors measuring x_1 or x_4 is faulty, the variable x_6 becomes inaccessible. The variable x_6 is said to be a “redundant variable of degree 0” or a “variable of minimal observability”.

3.3. Redundancy of any degree

This previous notion may be extended. A redundant variable of degree k is an observable variable which value remains deducible even when k whatever sensors simultaneously breakdown. Let us illustrate a redundancy of degree 2 considering the process of figure 3.

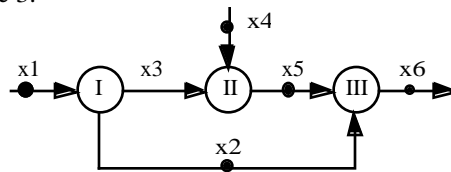

Figure 3: network number 2

There exist ten distinct combinations of two sensors simultaneously faulty among five. Let us consider the variable x_6 . The combinations involving the breakdowns of two sensors which do not measure the variable x_6 are not injurious to the observability of this variable because its value remains known by its direct measurement. There exist six combinations of this type, let us analyse the four remaining ones. Let us begin by remembering the equations describing the system:

$$\begin{aligned} x_1 - x_2 - x_3 &= 0 & (2a) \\ x_3 + x_4 - x_5 &= 0 & (2b) \\ x_2 + x_5 - x_6 &= 0 & (2c) \end{aligned}$$

If the sensors measuring the variables x_1 and x_6 are faulty, then equation (2c) allows the variable x_6 to be deduced because it is the only unknown quantity of this equation. The situation is identical if the sensors measuring the variables x_4 and x_6 are simultaneously faulty. If one of the following couple of sensor (x_2, x_6) or (x_5, x_6) is faulty, it is the equation issued from the “aggregation” of nodes I, II and III ($x_1 + x_4 - x_6 = 0$) that allows the variable x_6 to be deduced. In conclusion, the variable x_6 , which remains observable even when two whatever sensors are simultaneously faulty, is said to be redundant of degree 2.

3.4 Sensor placement and redundancy constraints

The preceding definitions allow any process variable to be characterised by its degree of redundancy which represent its availability with regard to sensor breakdowns. In order to simplify the presentation, let us consider a degree of redundancy equal to one only. The reader will easily verify, taking into account what it has been said before, the two following principles:

First principle: All the variables which intervene in a redundancy equation are, at least, redundant of degree 1.

Second principle: An unmeasured variable is redundant of degree 1 if, and only if, it intervenes at least in an equation in which all the other variables are redundant of degree 1.

Let us now consider the configuration of figure 4; the variable x_6 is redundant of degree 0 (observable variable).

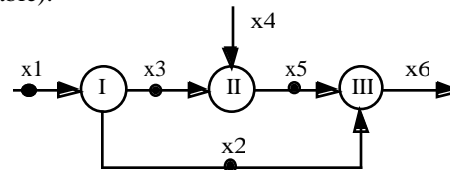

Figure 4: network number 3

$$x_1 - x_2 - x_3 = 0 \quad (3a)$$

$$x_3 + x_4 - x_5 = 0 \quad (3b)$$

$$x_2 + x_5 - x_6 = 0 \quad (3c)$$

Let us search where to place a sensor in order that the variable x_6 becomes redundant of degree 1. The value of this unmeasured variable may be deduced from those of x_2 and x_5 (eq. 3c). The variable x_2 is redundant of degree 1 because it intervenes in a redundancy equation (eq. 3a). On the other hand, x_5 is of minimal observability (redundancy degree equal to 0). If the sensor measuring x_5 is faulty, this variable becomes unobservable, consequently x_6 is no more deducible. So, for the variable x_6 to be redundant of degree 1, one can either measure the variable x_6 (application of the first principle) or measure x_4 in order to render x_5 redundant of degree 1 (application of the second principle).

The degrees of freedom concerning this very little example are rather limited. The goal was just to sensitise the reader to these concepts. However, we can now state the rules which allow any variable to be redundant of degree 1:

Rule 1: Measure all the variables of an equation comprising the concerned variable.

Rule 2: Measure all the variables which intervene in two independent equations involving the concerned variable except this later.

The generalisation of the previous rules to the case of a redundancy of any degree is immediate.

4. SYSTEMATIC APPROACH - ALGORITHMS

4.1 Observability analysis

Graph theory offers the possibility to describe a graph with different tools. In the first paragraph, we have mention the use of the incidence matrix. Another possibility consists in using the matrix of the fundamental cycles of this graph (Berge, 1983). This matrix may be easily deduced from the incidence

matrix. From this matrix of fundamental cycles, one can generate, by linear combinations, the matrix of all the cycles of the graph. The analysis of this cycle matrix allows the classification of variables to be obtained. It is based on the four fundamental following rules:

Rule I: A measured variable is estimable (redundant variable) if and only if it only belongs to cycles where at least two variables are measured.

Rule II: A measured variable is not estimable if and only if it belongs at least to a cycle where it is the only measured variable.

Rule III: An unmeasured variable is deducible (estimable) if and only if it only belongs to cycles with at least one measured variable.

Rule IV: An unmeasured variable is not deducible (non estimable) if and only if it belongs at least to a cycle where not any variable is measured.

So, the classification algorithm of variables includes the four following steps:

- 1) Determine the matrix of all the cycles of the graph, let C_t this matrix.
- 2) Extract from C_t the sub-matrix which comprises at most two measured variables (the knowledge of cycles which comprise more than two measurements is not necessary at this step)
- 3) Detect the cycles which do not involve measured variables; the unmeasured variables which belong to these cycles are the unmeasured and non estimable variables (*rule IV*). The other unmeasured variables of the process are the unmeasured but deducible variables.
- 4) Detect the cycles involving only one measured variable; the measured variables that belong to these cycles are the measured but non estimable variables (*rule II*). The other measured variables of the process are the measured and estimable variables).

Let us consider the process described by the graph of figure 5:

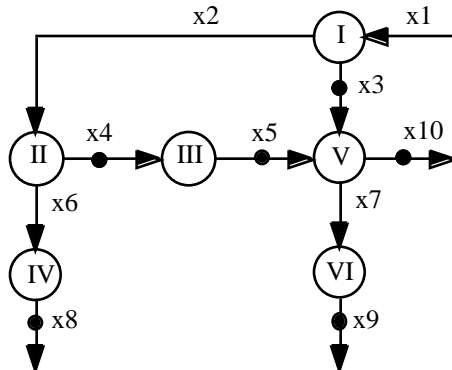

Figure 5: an elementary process

The matrix of all the cycles of this graph is given in table 1. Only the first four cycles are the fundamental cycles from which all the other cycles have been generated. The sub-matrix involving cycles compr-

ing at most two measured variables is given in table 2. The analysis of this last matrix leads to the following classification:

$$L_{me} = \{x3, x4, x5, x9, x10\} \quad L_{m\bar{e}} = \{x8\}$$

$$L_{\bar{m}e} = \{x1, x2, x6, x7\} \quad L_{\bar{m}\bar{e}} = \emptyset$$

| 1 | 2 | 3 | 4 | 5 | 6 | 7 | 8 | 9 | 10 |
|---|---|---|---|---|---|---|---|---|----|
| 1 | 1 | . | . | . | 1 | . | 1 | . | . |
| . | . | . | . | . | . | 1 | . | 1 | 1 |
| 1 | . | 1 | . | . | . | 1 | . | 1 | . |
| 1 | 1 | . | 1 | 1 | . | 1 | . | 1 | . |
| 1 | 1 | . | . | . | 1 | 1 | 1 | 1 | 1 |
| . | 1 | 1 | . | . | 1 | 1 | 1 | 1 | . |
| . | . | . | 1 | 1 | 1 | 1 | 1 | 1 | . |
| 1 | . | 1 | . | . | . | . | . | . | 1 |
| 1 | 1 | . | 1 | 1 | . | . | . | . | 1 |
| . | 1 | 1 | 1 | 1 | . | . | . | . | . |
| . | 1 | 1 | . | . | 1 | . | 1 | . | 1 |
| . | . | . | 1 | 1 | 1 | . | 1 | . | 1 |
| 1 | . | 1 | 1 | 1 | 1 | . | 1 | . | . |
| . | 1 | 1 | 1 | 1 | . | 1 | . | 1 | 1 |
| 1 | . | 1 | 1 | 1 | 1 | 1 | 1 | 1 | 1 |

Table 1: matrix C_t of all the cycles of the graph

| 1 | 2 | 3 | 4 | 5 | 6 | 7 | 8 | 9 | 10 |
|---|---|---|---|---|---|---|---|---|----|
| 1 | 1 | . | . | . | 1 | . | 1 | . | . |
| . | . | . | . | . | . | 1 | . | 1 | 1 |
| 1 | . | 1 | . | . | . | 1 | . | 1 | . |
| 1 | . | 1 | . | . | . | . | . | . | 1 |

Table 2: matrix of the cycles involving at most two measured variables

4.2 Determination of the redundancy degree

The determination of the degree of redundancy of a variable is obtained by applying the following rule which is an extension of the *rule I* involving the redundant variables (redundancy degree equal to 1):

Rule V: A variable is redundant of degree k if, and only if, it belongs to cycles comprising at least $k+1$ measured variables.

The degree of redundancy of a variable is easily determined by counting the minimum number of measured variables in the cycles where it intervenes. One may immediately deduce, for the considered example, that the variables $x1, x2, x6$ and $x8$ are of minimal observability; they intervene in a cycle comprising only one measurement. The variables $x3, x7, x9$ and $x10$ are redundant of degree 1 and the variables $x4$ and $x5$ are redundant of degree 2.

4.3 Sensor placement and redundancy constraints

Now, we propose a method for designing a measurement system satisfying some redundancy requirements. We first specify the lists the variables of which we ought to ensure a given degree of redundancy (list L_k for the variables which must be redundant of degree k). Moreover, a weight, proportional to the installation cost of the corresponding sensor, is associated to each variable. The main goal

of the design then consists in determining the variables which must be measured in order to satisfy the constraints on the degrees of redundancy whilst minimising the global cost of installation. Let n be the maximum required degree of redundancy, the proposed algorithm then comprises $n+1$ sequential steps. The k th step ensures a redundancy degree equal to k to the variables of the list L_k .

Step $n^{\circ}k$: Degree of redundancy of the variables belonging to L_k (for $k = 0, \dots, n$)

According to rule V, it is sufficient to measure $k+1$ variables per cycle comprising a variable belonging to L_k . This analysis is a combinatorial one; after having considered all the possibility of measurements for each cycle, we generate all the possible combinations of variables to be measured taking into account the measurements already chosen during the previous steps. We then select that corresponding to the minimal cost.

Let us consider the example of figure 5 without any sensors. Let us assume that the list of the variables required for the control is the following: $L_0 = \{x1, x4, x6, x9, x10\}$. In order to present a comprehensive example, let us specify a list of variables which must be redundant of degree 1 only: $L_1 = \{x1, x9\}$. The costs associated to each sensor are given in table 3:

| Var. | Cost | Var. | Cost |
|------|------|-------|------|
| $x1$ | 3 | $x6$ | 4 |
| $x2$ | 3 | $x7$ | 4 |
| $x3$ | 4 | $x8$ | 7 |
| $x4$ | 1 | $x9$ | 2 |
| $x5$ | 9 | $x10$ | 9 |

Table 3: costs associated to sensors

Now, we propose two approaches for solving the problem. The first one uses a matricial analysis while the second has recourse to linear programming.

Usage of matricial analysis

The number of all the combinations of variables which must be measured for ensuring the minimal observability of the variables belonging to L_0 is too important for being presented here. The reader may verify, generating these combinations, that the minimal cost solution consists in measuring the variables $x1, x2, x4$ and $x9$. During step $n^{\circ}1$, one searches to ensure to variables $x1$ and $x9$, a degree of redundancy equal to one. It is then necessary to consider cycles comprising less than two already measured variables. The sub-matrix of these cycles, where the measured variables are boldfaced, is given table 4.

| 1 | 2 | 3 | 4 | 5 | 6 | 7 | 8 | 9 | 10 |
|----------|----------|---|----------|---|---|---|---|----------|----|
| . | . | . | . | . | . | 1 | . | 1 | 1 |
| 1 | . | 1 | . | . | . | . | . | 1 | 1 |
| . | 1 | 1 | . | . | 1 | . | 1 | . | 1 |
| . | . | . | 1 | 1 | 1 | . | 1 | . | 1 |

Table 4: sub-matrix of the useful cycles

Only the first two cycles comprise the variables $x1$ and $x9$ and they are already measured. For the first cycle, the possible combinations of variables to be

measured are $\{x7\}$ or $\{x10\}$ and for the second one $\{x10\}$ or $\{x3\}$.

The constraints on the degree of redundancy will be satisfied if one of the following sets of variables: $\{x7, x10\}$, $\{x7, x3\}$, $\{x3, x10\}$ or $\{x10\}$ is measured. The minimal cost solution then consists in measuring the variables $x3$ and $x7$. It is very important to note that the minimisation of the cost implies the installation of the two sensors measuring $x3$ and $x7$ (cost equal to 8) whilst the sole respect of constraints on the redundancy degrees will lead to the installation of only one sensor measuring the variable $x10$ (cost equal to 9). This remark points out the importance of the choice of the optimised criterion which could, for example, take also into account the number of sensors to be installed. In conclusion, the set of variables which must be measured for satisfying the different given constraints whilst minimising the cost is the following: $\{x1, x2, x3, x4, x7, x9\}$. The corresponding cost is equal to 17 ($3+3+4+1+4+2$).

Usage of mixed linear programming approach

Recently, some authors have introduced the usage of mixed linear programming for solving both the problem of variable classification according to their observability and that of sensor placement (Immonen, 1994), (Bagajewicz, 1995). The following presentation uses these ideas. Indeed, sensor placement subject to redundancy constraints may easily be transformed into linear programming problem.

The formulation of the problem comes from the analysis of the preceding proposed algorithm. Let us assume that the matrix of all the cycles of the graph has already been generated. Sensor placement consists in measuring a given number of variables per cycles depending on the redundancy degree which must be ensured whilst minimising the associated cost. We claim that this problem can be formulated as follows:

$$\begin{array}{ll} \text{Minimise} & C^T U \\ \text{Subject to} & A U \geq B \end{array}$$

where C is the cost vector of dimension v . $U = [u_i]$ is the unknown vector of Boolean numbers which indicates the variables which must be measured to meet the redundancy constraints (1 : must be measured, 0 : elsewhere). A is a cycle matrix the construction of which will be explained latter and B is a vector which entries are equal to the minimum number of measurements per cycle for satisfying the redundancy constraints.

Let us now explain the construction of A and B . The matrix A is built from the matrix of all the cycles of the graph from which the cycles involving variables which do not belong to any lists L_k have been removed. Indeed, there is not any constraints on the variables belonging to these cycles. The entries of the vector B are computed as follows. If a cycle contains a variable belonging to the list L_k , the

redundancy constraints will be satisfied only if $k+1$ variables belonging to this cycle are measured. As a cycle may contain variables belonging to different lists L_k , the entry b_i will be equal to the maximum number of variables which must be measured. If a given cycle contains less variables than this minimum number of variables to be measured, the problem has no solution, except if we accept to use hardware redundancy, that is to say to place more than one sensor for measuring a variable.

Let us again consider the example of figure 5 with the same constraints and the same costs. The matrix of all the cycles of the graph is given in table 1. For this example, the reader will verify that, as one variable belonging either to L_0 or L_1 intervenes, at least, in each cycle, the matrix A is equal to the matrix of all the cycles, C_i . Moreover, except for the 10th, 11th and 12th cycles, which do not contain variables x_1 or x_9 , that is to say that b_{10} , b_{11} and b_{12} are equal to 1, the other entries of B are all equal to 2. The problem has been solved by using the public domain code LP_SOLVE¹. The entry file is given below:

```
min:3x1+3x2+4x3+x4+9x5+4x6+4x7+7x8+2x9+9x10;
x1+x2+x6+x8 >= 2;
x7+x9+x10 >= 2;
x1+x3+x7+x9 >= 2;
x1+x2+x4+x5+x7+x9 >= 2;
x1+x2+x6+x7+x8+x9+x10 >= 2;
x2+x3+x6+x7+x8+x9 >= 2;
x4+x5+x6+x7+x8+x9 >= 2;
x1+x3+x10 >= 2;
x1+x2+x4+x5+x10 >= 2;
x2+x3+x4+x5 >= 1;
x2+x3+x6+x8+x10 >= 1;
x4+x5+x6+x8+x10 >= 1;
x1+x3+x4+x5+x6+x8 >= 2;
x2+x3+x4+x5+x7+x9+x10 >= 2;
x1+x3+x4+x5+x6+x7+x8+x9+x10 >= 2;

x1 <= 1; x2 <= 1; x3 <= 1; x4 <= 1;
x5 <= 1; x6 <= 1; x7 <= 1; x8 <= 1;
x9 <= 1; x10 <= 1;

int x1, x2, x3, x4, x5, x6, x7, x8, x9, x10;
```

The reader will notice the second group of constraints. As LP_SOLVE can only handle positive values for the variables and taking into account their declaration as integers, the optimization variables are constrained to be Boolean. The results, of course, are the same as those presented before.

5. CONCLUSION

During its analysis step, the proposed method allows the different variables to be classified according to their redundancy degree. This classification is very important because it gives informations about

dependability with regard to sensor breakdowns. During the synthesis step, the measurement system design is done by optimising a unique criterion related to cost of installation subject to redundancy constraints. Others criteria could have been taken into account. The formulation of a multicriteria problem including observability, reliability, degree of redundancy, accuracy of deduction, costs of sensors is undoubtedly a fruitful future research direction.

REFERENCES

- Ali, Y. and S. Narasimhan (1993). Sensor network design for maximizing reliability of linear processes. *AICHE Journal*, **39** (5), pp. 820-828.
- Berge, C. (1983). *Graphes*, Gauthier-Villard, Paris.
- Bagajewicz, M.J. (1995). Optimal sensor location in process plants. *Proc. of the Fifth European Symposium on Computer Aided Process Engineering, Escape'95*, Bled, Slovenia, June 11-14.
- Crowe, C.M., Y.A. Garcia Campos and A. Hrymak (1983). Reconciliation of process flow rates by matrix projection-part I. The linear case. *AICHE Journal*, **29** (6), 881-888.
- Crowe, C.M. (1989). Observability and redundancy of process data for steady state reconciliation. *Chemical Engineering Science*, **12**, 2909-2917.
- Immonen, P.J. (1994). Classification and placement of measurements through LP/MIP algorithms. *Proc. of Symposium on Fault Detection, Supervision and Safety for Technical Processes, Safeprocess'94*, Espoo, Finland, June 13-15.
- Luong, M., D. Maquin, C.T. Huynh and J. Ragot (1994). Observability, redundancy, reliability and integrated design of measurement system. *Proc of 2nd IFAC Symposium on Intelligent Components and Instruments for Control Applications, SICICA'94*, Budapest, Hungary, June 8-10.
- Mah, R.S.H., G.M. Stanley and D.M. Downing (1976). Reconciliation and rectification of process flow and inventory data. *I.E.C. Process Design Development*, **15** (1), 175-183.
- Madron, F. and V. Veverka (1992). Optimal selection of measuring points in complex plant by linear models. *AICHE Journal*, **38** (2), 227-236.
- Maquin, D., M. Luong and J. Ragot (1994). Observability analysis and sensor placement. *Proc. of Symposium on Fault Detection, Supervision and Safety for Technical Processes Safeprocess'94*, Espoo, Finland, June 13-15.
- Ragot, J., M. Darouach, D. Maquin and G. Bloch (1990). *Validation de données et diagnostic*. Traité des nouvelles technologies, série diagnostic et maintenance, Hermès, Paris.
- Stanley, G.M. and R.S.H. Mah (1981). Observability and redundancy in process data estimation. *Chemical Engineering Science*, **36**, 259-272.
- Vaclavek, V. (1969). Studies on system engineering III. Optimal choice of the balance measurements in complicated chemical engineering systems. *Chemical Engineering Science*, **24**, 947-955.

¹LP_SOLVE is a public domain code written in C by M. Berkelaar (michel@es.ele.tue.nl). It can be retrieved from the address ftp://ftp.es.ele.tue.nl/pub/lp_solve