



HAL
open science

Nanoparticle formation by ozonolysis of inducible plant volatiles

J. Joutsensaari, M. Loivamäki, T. Vuorinen, P. Miettinen, A.-M. Nerg, J. K. Holopainen, A. Laaksonen

► **To cite this version:**

J. Joutsensaari, M. Loivamäki, T. Vuorinen, P. Miettinen, A.-M. Nerg, et al.. Nanoparticle formation by ozonolysis of inducible plant volatiles. *Atmospheric Chemistry and Physics Discussions*, 2005, 5 (1), pp.1-16. hal-00300908

HAL Id: hal-00300908

<https://hal.science/hal-00300908>

Submitted on 18 Jun 2008

HAL is a multi-disciplinary open access archive for the deposit and dissemination of scientific research documents, whether they are published or not. The documents may come from teaching and research institutions in France or abroad, or from public or private research centers.

L'archive ouverte pluridisciplinaire **HAL**, est destinée au dépôt et à la diffusion de documents scientifiques de niveau recherche, publiés ou non, émanant des établissements d'enseignement et de recherche français ou étrangers, des laboratoires publics ou privés.

**Particle formation by
ozonolysis of plant
volatiles**

J. Joutsensaari et al.

Nanoparticle formation by ozonolysis of inducible plant volatiles

**J. Joutsensaari¹, M. Loivamäki^{2,3}, T. Vuorinen², P. Miettinen¹, A.-M. Nerg²,
J. K. Holopainen², and A. Laaksonen¹**

¹Department of Applied Physics, University of Kuopio, P.O. Box 1627, FIN-70211 Kuopio, Finland

²Department of Ecology and Environmental Science, University of Kuopio, P.O. Box 1627, Kuopio FIN-70211, Finland

³Institute for Meteorology and Climate Research – Atmospheric Environmental Research (IMK-IFU), Kreuzteckbahnstrasse 19, 82467 Garmisch-Partenkirchen, Germany

Received: 25 November 2004 – Accepted: 14 December 2004 – Published: 10 January 2005

Correspondence to: J. Joutsensaari (jorma.joutsensaari@uku.fi)

© 2005 Author(s). This work is licensed under a Creative Commons License.

Title Page

Abstract

Introduction

Conclusions

References

Tables

Figures

◀

▶

◀

▶

Back

Close

Full Screen / Esc

Print Version

Interactive Discussion

EGU

Abstract

We present the first laboratory experiments of aerosol formation from oxidation of volatile organic species emitted by living plants, a process which for half a century has been known to take place in the atmosphere. We have treated white cabbage crops with methyl jasmonate in order to induce the production of monoterpenes and certain less-volatile sesqui- and homoterpenes. Ozone was introduced into the growth chamber in which the crops were placed, and the subsequent aerosol formation and growth of aerosols were monitored by measuring the particle size distributions continuously during the experiments. Our observations show similar particle formation rates as in the atmosphere but much higher growth rates. The results indicate that the concentrations of nonvolatile oxidation products of plant released precursors needed to induce the nucleation are roughly an order-of-magnitude higher than their concentrations during atmospheric nucleation events. Our results therefore suggest that atmospheric nucleation events proceed via condensation of oxidized organics on pre-existing molecular clusters rather than via their homogeneous or ion-induced nucleation.

1. Introduction

The largest uncertainties in forward calculations of warming of the atmosphere due to greenhouse gases are related to our limited knowledge of negative solar radiative forcing associated with aerosols (Anderson et al., 2003). Formation of secondary organic aerosols (SOA), i.e., particle production from volatile organic compounds (VOCs) by chemical reactions, is one of the main processes that affect the composition and properties of atmospheric particles. Recent estimates on the importance of SOA formation show that it may be significant when compared to the primary organic aerosol emissions: about 60% of the organic aerosol mass is SOA on the global scale and regionally even more (Kanakidou et al., 2004).

Volatile monoterpenes and isoprene, which are the main biogenic VOCs in the atmo-

Particle formation by ozonolysis of plant volatiles

J. Joutsensaari et al.

Title Page

Abstract

Introduction

Conclusions

References

Tables

Figures

◀

▶

◀

▶

Back

Close

Full Screen / Esc

Print Version

Interactive Discussion

**Particle formation by
ozonolysis of plant
volatiles**J. Joutsensaari et al.

[Title Page](#)[Abstract](#)[Introduction](#)[Conclusions](#)[References](#)[Tables](#)[Figures](#)[◀](#)[▶](#)[◀](#)[▶](#)[Back](#)[Close](#)[Full Screen / Esc](#)[Print Version](#)[Interactive Discussion](#)

EGU

sphere, are known to contribute to SOA formation (Claeys et al., 2004; Kanakidou et al., 2004). The current evidence from reaction chamber studies (Bonn and Moortgat, 2003) suggests that inducible VOCs with low volatility such as sesqui- and homoterpenes might be even more effective in reactions with O₃ and subsequent formation of aerosol particles. Substantial increases in total terpene emissions from plants have been detected after herbivore-feeding damage (Vuorinen et al., 2004b). Furthermore, plants damaged by insects (Vuorinen et al., 2004b) or ozone (Vuorinen et al., 2004a) start to emit certain less-volatile sesqui- and homoterpenes which are not emitted in substantial amounts from intact plants. An increase in the amount of biogenic VOCs can significantly affect SOA formation locally, e.g., during air pollution episodes. Furthermore, these inducible VOCs act as an indirect plant defense by attracting the natural enemies of herbivores (Dicke and van Loon, 2000; Holopainen, 2004).

Here, we present the first laboratory demonstration of aerosol nucleation from oxidation of volatile organic species emitted by living plants. We have measured particle formation over chemically treated cabbage plants during ozone pulses. The plants were treated with methyl jasmonate elicitor to increase and induce emissions of different terpenes. We show that a more likely atmospheric nucleation mechanism than homogeneous or ion-induced nucleation of oxidized organics is their heterogeneous condensation on pre-existing molecular clusters.

2. Experimental

White cabbage (*Brassica oleracea* subspecies *capitata*, cultivars Lennox and Rinda) plants were used as a source of biogenic VOCs in our experiments. Cabbages are important crop plants cultivated in both hemispheres, and as a constitutive monoterpene emitters with inducible sesqui- and homoterpene emissions (Mattiacci et al., 1995; Vuorinen et al., 2004b) suitable test plants for VOC experiments. Cabbage plants were used in two different experiments: i) aerosol formation experiments to determine new particle formation during ozone pulses over chemically treated plants, and

ii) VOC emission analyses to determine VOC emissions from individual intact (control) and treated plants (induced emission). We used methyl jasmonate (MeJA) treatment (Loivamäki et al., 2004) in order to artificially initiate emission spectrum that is typical to herbivore-damaged plants (Vuorinen et al., 2004b).

5 2.1. Plant material and treatments

Seedlings of white cabbage (cultivars Lennox and Rinda) were individually sown in 1-l plastic pots filled with *Sphagnum* peat and sand (3:1 v/v) and pre-grown in a greenhouse for 28 days. The plants were then transferred into computer controlled growth chambers (Bioklim 2600T, Kryo-Service Oy, Helsinki, Finland) and maintained at 23:18°C, 70:80% relative humidity and 22 h light: 2 h dark photoperiod (250 $\mu\text{mol m}^{-2} \text{s}^{-1}$ PAR during light period). Separate plants were used for VOC analyses and aerosol formation experiments with O₃ pulses.

To enhance emissions of monoterpenes and to induce emissions of homoterpenes and sesquiterpenes, the cabbage plants were sprayed with an aqueous MeJA solution (10 mmol water solution, approx. 7 ml per plant) about 2–4 days before the experiments. VOCs were analyzed individually from intact (control plants) and MeJA-treated cabbages.

2.2. VOC analyses of individual plants

VOC emissions of the control and MeJA-treated cabbages were measured from five individual plants for both cultivars (Lennox and Rinda). Before sampling the root system of the plant was rinsed and slightly pruned and placed in a 15 ml vial filled with tap water. The plants were individually enclosed inside 1-l glass vessels closed with Teflon-sealed lids with an inlet for purified pressurized air and an outlet for sampling. VOC samples were collected for 0.5 h on about 150 mg Tenax-TA adsorbent (Supelco, mesh 60/80) from plant headspace through Teflon tubing. The flow rate was set to 0.215 l min⁻¹ for the compensation air and 0.200 l min⁻¹ for the sampling. The VOC

Particle formation by ozonolysis of plant volatiles

J. Joutsensaari et al.

Title Page

Abstract

Introduction

Conclusions

References

Tables

Figures

◀

▶

◀

▶

Back

Close

Full Screen / Esc

Print Version

Interactive Discussion

collection was performed at 22°C and at 250 $\mu\text{mol m}^{-2} \text{s}^{-1}$ PAR at ambient CO_2 and zero O_3 concentration. Samples were analyzed by gas chromatography-mass spectrometry (GC-MS, Hewlett Packard GC type 6890, MSD 5973) after desorption (Perkin Elmer ATD400). Emissions were calculated as $\text{ng (g dry weight)}^{-1} \text{h}^{-1}$. The sample analysis has been described in detail elsewhere (Vuorinen et al., 2004b).

2.3. Aerosol formation experiments

Figure 1 shows the experimental set-up used in aerosol formation experiments. The experiments were carried out in a 2.6 m^3 growth chamber (Bioklim 2600T, height 1.75 m, bottom area 1.55 $\text{m} \times 0.97 \text{ m}$). MeJA-treated cabbage plants (40 cv. Lennox and 35 cv. Rinda) were situated on a wire-net table about 0.20 m above the bottom of the chamber in similar growth conditions as described earlier. Aerosol samples were taken at the height of about 0.5 m above the plants. During the ozonolysis experiments, a forced air circulation in the chamber was turned off to prevent particle losses and condensation of volatile vapors to the heat exchanger of the air circulation system. Furthermore, the intensity of the lights was reduced from nominal values to the level of about 100 $\mu\text{mol m}^{-2} \text{s}^{-1}$ PAR to prevent increase in temperature. Filtered pressurized air flow of about 5 l min^{-1} was fed to the chamber to carry O_3 as well as to keep it slightly over pressured during the experiments. O_3 was generated from pure oxygen (Fisher OZ500 O_3 generator) and continuously monitored (Dasibi Model 1008-RS O_3 analyzer). In addition, relative humidity (RH) and temperature were determined continuously with a RH and temperature transmitter (Vaisala Humitter Y50) at the height of about 0.5 m above the plants. VOC composition in the chamber air was collected with Perkin Elmer Sequential Tube Sampler (Model STS 25) into Tenax-TA tubes before the start of aerosol formation experiment with O_3 . The VOC samples were analyzed as described earlier.

Particle formation and growth during O_3 exposure in the chamber was determined by measuring the aerosol particle number size distributions with a differential mobility particle sizer (DMPS, Knutson and Whitby, 1975). The particle size distributions were

**Particle formation by
ozonolysis of plant
volatiles**

J. Joutsensaari et al.

Title Page

Abstract

Introduction

Conclusions

References

Tables

Figures

◀

▶

◀

▶

Back

Close

Full Screen / Esc

Print Version

Interactive Discussion

**Particle formation by
ozonolysis of plant
volatiles**J. Joutsensaari et al.

[Title Page](#)[Abstract](#)[Introduction](#)[Conclusions](#)[References](#)[Tables](#)[Figures](#)[◀](#)[▶](#)[◀](#)[▶](#)[Back](#)[Close](#)[Full Screen / Esc](#)[Print Version](#)[Interactive Discussion](#)

EGU

measured every 7 min in the size range of 5.5–70 nm. In addition, total number concentration of particles starting from about 5 nm up to several micrometers in diameter was measured with a condensation particle counter (CPC, TSI Model 3010) with a time resolution of 10 s. The DMPS system consists of a 10.9 cm long Hauke-type differential mobility analyzer (DMA, [Winklmayr et al., 1991](#)), which is used to classify the aerosol particles based on their electrical mobility, and a condensation particle counter (CPC, TSI Model 3010), which is used to measure the concentration of size-classified particles. The DMA was operated with aerosol and sheath flows of 1 and 10 l min⁻¹, respectively, and the sheath and excess flows were controlled by a closed-loop flow arrangement with a critical orifice. The sample aerosol was neutralized with a radioactive β -source (Ni-63) before the DMA. To measure particles down to about 5 nm in diameter, the temperature difference between saturator and condenser was increased to 25°C in both CPCs ([Mertes et al., 1995](#)). From the measured DMPS data, particle size distributions were determined using a Tichonov regularization method with a smoothness constraint ([Voutilainen et al., 2001](#)). CPC counting efficiency and diffusional particle losses in the tubing and the DMA were taken account in the data analysis.

Before particle production experiments with plants, blank chamber tests were performed in order to determine effects of impurities in the empty chamber

3. Results and discussion

3.1. Plant experiments

Table 1 shows results from the GC-MS analyses of the emissions from the control (intact) and MeJA-treated cabbages for cultivars Lennox and Rinda. The results indicated 2 to 10-fold increase in monoterpene emissions from MeJA treated plants. In addition, homoterpene (*E*)-4,8-dimethyl-1,3,7-nonatriene (DMNT), sesquiterpene (*E, E*)- α -farnesene, and (*Z*)-3-hexenyl acetate which are typical to cabbage plants damaged by diamondback moth larvae ([Vuorinen et al., 2004b](#)) were emitted from MeJA-treated

**Particle formation by
ozonolysis of plant
volatiles**J. Joutsensaari et al.

[Title Page](#)[Abstract](#)[Introduction](#)[Conclusions](#)[References](#)[Tables](#)[Figures](#)[◀](#)[▶](#)[◀](#)[▶](#)[Back](#)[Close](#)[Full Screen / Esc](#)[Print Version](#)[Interactive Discussion](#)

EGU

plants. In cultivar Rinda, control plants also emitted green leaf volatiles (GLVs, (*Z*)-3-hexen-1-ol, (*E*)-2-hexenal and (*Z*)-3-hexenyl acetate) and (*E,E*)- α -farnesene indicating possible mechanical damage during handling. The analyses of chamber air where MeJA-treated plants (both cultivars) were grown 14 to 24 h after the MeJA spraying, but before O₃ pulses indicated that all the terpenoids listed in Table 1 were detectable except DMNT. Limonene, (*E,E*)- α -farnesene, sabinene and α -thujene were the most abundant terpenes in the air before noon.

The results show that MeJA-treated plants are more efficient in releasing aerosol precursors than non-treated intact plants, suggesting that inducible VOCs released by stressed plants are important aerosol particle precursors also at the canopy level.

For comparison, the main VOCs emitted from Scots pine (one of the most common species in the boreal forest) are Δ^3 -carene, α -pinene and β -pinene according to recent measurements in two locations in Finland (Tarvainen et al., 2004). They contribute 60–85% of the total observed monoterpene emission rates. Globally the main monoterpenes are α -pinene, β -pinene and limonene (Kanakidou et al., 2004). Although the spectrum of the VOCs emitted by the cabbages is somewhat different from the emission spectrum of e.g. Scots pines, we believe that it is more representative of atmospheric conditions than the VOCs or mixtures of VOCs commonly used in smog chamber experiments.

3.2. Blank chamber tests

Two sets of blank chamber tests were performed to determine effects of impurities in the empty chamber. In the first set, we observed particle production during the first ozonolysis of an empty chamber, but no aerosols were formed during subsequent periods when O₃ was introduced into the chamber. We interpret this as a wall effect: volatile organics produced by plants that were placed in the chambers previously had adsorbed on chamber walls and reacted with O₃ during the first ozonolysis experiment forming new particles. During the ozonolysis, those organics were depleted from the walls and therefore no particle production was observed afterwards. The second blank

chamber test set was performed after the experiments with MeJA-treated plants. In this set, no nucleation was observed during chamber ozonolysis. This confirmed that the aerosol nucleation events observed during the plant ozonolysis experiments were actually caused by species emitted by the plants and not by impurities on the chamber walls.

3.3. Aerosol formation experiments

Figure 2 shows a contour plot of aerosol particle number size distributions, total aerosol particle number and O_3 concentrations, temperature and RH during aerosol formation experiments over MeJA-treated plants. Rapid particle production was observed during two consecutive ozonolysis (400 and 270 ppbv O_3 , respectively) experiments. Background particle number concentration and average particle diameter were about 2700 cm^{-3} and 35 nm, respectively, before the first ozone pulse. During the ozonolysis, particle concentration increased to about 5500 cm^{-3} within 15 min and then started to decrease due to particle coagulation and deposition. During the second experiment about 3 hours later, particle concentration increased from 950 to 3000 cm^{-3} in 15 min. Relative humidity varied between 31–44% and temperature between 26–30°C during the experiments.

The most important quantities characterizing the intensity of the new particle formation events are particle formation rate (number of particles formed in unit volume and time) and growth rate (increase of particle diameter in unit time). The former is dependent on condensable vapor supersaturation level, while the latter depends on the absolute difference between the partial pressure and the saturation vapor pressure. The particle formation rates (or more precisely, 5 nm particle appearance rates) during the nucleation events were 3.1 and $2.3\text{ cm}^{-3}\text{ s}^{-1}$. These numbers are well comparable to particle formation rates observed in ambient air, which vary between $0.01\text{--}10\text{ cm}^{-3}\text{ s}^{-1}$ in the continental boundary layer (Kulmala et al., 2004). The particle growth rates, on the other hand, were on the order of $40\text{--}70\text{ nm h}^{-1}$, corresponding to condensable vapor mixing ratios of 0.02–0.03 ppbv. The growth rates of particles formed in atmo-

**Particle formation by
ozonolysis of plant
volatiles**

J. Joutsensaari et al.

Title Page

Abstract

Introduction

Conclusions

References

Tables

Figures

◀

▶

◀

▶

Back

Close

Full Screen / Esc

Print Version

Interactive Discussion

spheric nucleation events, as well as the corresponding condensable vapor mixing ratios, are usually an order of magnitude lower, the maximum observed growth rate being 20 nm h^{-1} (Kulmala et al., 2004).

The disparity between particle growth rates in our experiments and in the atmosphere contradicts the theory (Bonn and Moortgat, 2003) that atmospheric nucleation events are caused by homogeneous nucleation of ozonolysis products of volatile compounds released by plants: our experiments show that the condensable vapor concentrations required to produce the nucleation are roughly ten times higher than those related to atmospheric particle formation events. Furthermore we did not shield the growth chamber from cosmic rays, so that ions have been created in the chamber air during our experiments. We would expect the ionization rate to be on the same order as the observed particle formation rates, and it is therefore possible that the nucleation we observed was ion-induced. But whatever the actual nucleation mechanism, the required vapor concentrations are still higher than what are needed for atmospheric nucleation. Our results therefore also contradict the possibility that atmospheric particle formation events are caused by ion-induced nucleation of oxidized organics.

Although it seems that the nucleation in our growth chamber proceeded with a different mechanism than in the atmosphere, we believe that our experimental results are in fact consistent with the atmospheric observations. Another theory put forward recently (see e.g. Kulmala, 2003) holds that in the atmosphere, thermodynamically stable molecular clusters with diameters of about 1 nm are formed due to clustering of sulfuric acid and possibly ammonia and water molecules. Subsequently, other, presumably organic, vapors are needed to nucleate heterogeneously on the sulfate clusters, speeding up cluster growth so that the clusters survive to detectable sizes ($>3 \text{ nm}$) before they are scavenged due to coagulation with larger particles. In our experiments, there were no sulfate clusters present, and hence the non-volatile organics formed in the ozonolysis reactions nucleated homogeneously. The supersaturation required for homogeneous nucleation is higher than that required for heterogeneous nucleation and thus the organic vapor levels needed for particle production are higher in the chamber

**Particle formation by
ozonolysis of plant
volatiles**J. Joutsensaari et al.

[Title Page](#)[Abstract](#)[Introduction](#)[Conclusions](#)[References](#)[Tables](#)[Figures](#)[◀](#)[▶](#)[◀](#)[▶](#)[Back](#)[Close](#)[Full Screen / Esc](#)[Print Version](#)[Interactive Discussion](#)

experiments compared with the atmosphere. This explains why we observe more rapid growth of particles than what is encountered in atmospheric conditions.

Furthermore, the absence of nucleation events in the Amazon suggests that new particle formation purely from SOA compounds may not be frequent in environments with very high biogenic VOC concentrations but very low sulfur concentrations (Kanakidou et al., 2004). The conditions in our experiments are similar with the exception of higher O₃ concentration that can induce particle formation via homogenous nucleation. This also supports our suggestion that the main particle formation mechanism in the atmosphere is condensation of oxidized organics on pre-existing molecular clusters but homogenous nucleation in our chamber experiments.

4. Conclusions

We have studied formation and growth of aerosol particles over white cabbage plants during O₃ exposure in a growth chamber. The plants had been treated with methyl jasmonate (MeJA) elicitor to artificially initiate an emission spectrum that is typical to herbivore-damaged plants and to induce emissions of homo- and sesquiterpenes. In addition, we have determined emissions of volatile organic compounds (VOCs) from individual intact (control) and MeJA-treated plants for emission comparison.

The VOC emission analyses from individual plants show that MeJA-treated plants are more efficient in releasing aerosol precursors than non-treated plants, suggesting that inducible VOCs released by stressed plants are important aerosol particle precursors at the canopy level. Current estimates of phytogenic VOC emissions have predominantly assessed isoprene and monoterpene emission rates of different plant species (Kesselmeier and Staudt, 1999). To better assess aerosol forming capacity of vegetation, it is essential to evaluate the whole emitted VOC spectrum of different plant species including sesquiterpenes and other inducible terpenes. Furthermore, herbivore-induced compounds released by damaged plants attract the natural enemies of herbivores, and thereby defend plants indirectly. However, during peak O₃ episodes

**Particle formation by
ozonolysis of plant
volatiles**

J. Joutsensaari et al.

Title Page

Abstract

Introduction

Conclusions

References

Tables

Figures

◀

▶

◀

▶

Back

Close

Full Screen / Esc

Print Version

Interactive Discussion

**Particle formation by
ozonolysis of plant
volatiles**J. Joutsensaari et al.

[Title Page](#)[Abstract](#)[Introduction](#)[Conclusions](#)[References](#)[Tables](#)[Figures](#)[◀](#)[▶](#)[◀](#)[▶](#)[Back](#)[Close](#)[Full Screen / Esc](#)[Print Version](#)[Interactive Discussion](#)

EGU

inducible VOCs released after herbivore damage may degrade fast and lose their ecological signaling value (Holopainen, 2004) to natural enemies of herbivores. Recently, it has been proposed that crop plants should be genetically engineered to produce these inducible volatiles (Degenhardt et al., 2003). Cultivation of such “self defending” crops might reduce pesticide use, but air pollutants (e.g. O₃, NO_x) that destroy emitted volatiles could decrease the efficiency of this strategy.

Our aerosol particle size distribution measurements showed rapid particle formation during ozonolysis experiments. To our knowledge, aerosol production due to ozonolysis of plant-released VOCs has not been demonstrated in the laboratory prior to this work. The observed particle formation rates were well in the range observed in atmospheric nucleation events; however, particle growth rates were clearly higher. The results indicate that the concentrations of nonvolatile oxidation products of plant released precursors needed to induce the nucleation are roughly an order-of-magnitude higher than their concentrations during atmospheric nucleation events. Our results therefore suggest that atmospheric nucleation events proceed via condensation of oxidized organics on pre-existing molecular clusters rather than via their homogeneous or ion-induced nucleation.

Acknowledgements. This work was supported by the Academy of Finland, decisions no. 105209 and 202300 (M. Loivamäki, T. Vuorinen, A.-M. Nerg, J. K. Holopainen) project 52476 and the Center of Excellence program (A. Laaksonen, J. Joutsensaari) and by Emil Aaltonen Foundation (J. Joutsensaari and P. Miettinen). The authors want to thank T. Oksanen for his help during the experiments and the staff at the Kuopio University Research Garden for maintaining the plants.

References

Anderson, T. L., Charlson, R. J., Schwartz, S. E., Knutti, R., Boucher, O., Rodhe, H., and Heintzenberg, J.: Climate forcing by aerosols – a hazy picture, *Science*, 300, 1103–1104, 2003. 2

**Particle formation by
ozonolysis of plant
volatiles**

J. Joutsensaari et al.

[Title Page](#)[Abstract](#)[Introduction](#)[Conclusions](#)[References](#)[Tables](#)[Figures](#)[◀](#)[▶](#)[◀](#)[▶](#)[Back](#)[Close](#)[Full Screen / Esc](#)[Print Version](#)[Interactive Discussion](#)

EGU

- Bonn, B. and Moortgat, G. K.: Sesquiterpene ozonolysis: Origin of atmospheric new particle formation from biogenic hydrocarbons, *Geophys. Res. Lett.*, 30, 1585, doi:10.1029/2003GL017000, 2003. [3](#), [9](#)
- 5 Claeys, M., Graham, B., Vas, G., Wang, W., Vermeylen, R., Pashynska, V., Cafmeyer, J., Guyon, P., Andreae, M. O., Artaxo, P., and Maenhaut, W.: Formation of secondary organic aerosols through photooxidation of isoprene, *Science*, 303, 1173–1176, 2004. [3](#)
- Degenhardt, J., Gershenzon, J., Baldwin, I. T., and Kessler, A.: Attracting friends to feast on foes: engineering terpene emission to make crop plants more attractive to herbivore enemies, *Curr. Opin. Biotechnol.*, 14, 169–176, 2003. [11](#)
- 10 Dicke, M. and van Loon, J. J. A.: Multitrophic effects of herbivore-induced plant volatiles in an evolutionary context, *Entomol. Exp. Appl.*, 97, 237–249, 2000. [3](#)
- Holopainen, J. K.: Multiple functions of inducible plant volatiles, *Trends Plant Sci.*, 9, 529–533, 2004. [3](#), [11](#)
- Kanakidou, M., Seinfeld, J. H., Pandis, S. N., Barnes, I., Dentener, F. J., Facchini, M. C., Van Dingenen, R., Ervens, B., Nenes, A., Nielsen, C. J., Swietlicki, E., Putaud, J. P., Balkanski, Y., Fuzzi, S., Horth, J., Moortgat, G. K., Winterhalter, R., Myhre, C. E. L., Tsigaridis, K., Vignati, E., Stephanou, E. G., and Wilson, J.: Organic aerosol and global climate modelling: A review, *Atmos. Chem. Phys. Discuss.*, 4, 5855–6024, 2004, [SRef-ID: 1680-7375/acpd/2004-4-5855](#). [2](#), [3](#), [7](#), [10](#)
- 20 Kesselmeier, J. and Staudt, M.: Biogenic volatile organic compounds (VOC): An overview on emission, physiology and ecology, *J. Atmos. Chem.*, 33, 23–88, 1999. [10](#)
- Knutson, E. O. and Whitby, K. T.: Aerosol classification by electric mobility: apparatus, theory and applications, *J. Aerosol Sci.*, 6, 443–451, 1975. [5](#)
- Kulmala, M.: How particles nucleate and grow, *Science*, 302, 1000–1001, 2003. [9](#)
- 25 Kulmala, M., Vehkamäki, H., Petäjä, T., Dal Maso, M., Lauri, A., Kerminen, V.-M., Birmili, W., and McMurry, P. H.: Formation and growth rates of ultrafine atmospheric particles: a review of observations, *J. Aerosol Sci.*, 35, 143–176, 2004. [8](#), [9](#)
- Loivamäki, M., Holopainen, J. K., and Nerg, A.-M.: Chemical changes induced by methyl jasmonate in oilseed rape grown in the laboratory and in the field, *J. Agric. Food Chem.*, 52 (25), 7607–7613, 2004. [4](#)
- 30 Mattiacci, L., Dicke, M., and Posthumus, M. A.: Beta-Glucosidase – An Elicitor of Herbivore-Induced Plant Odor That Attracts Host-Searching Parasitic Wasps, *Proc. Natl. Acad. Sci. U. S. A.*, 92, 2036–2040, 1995. [3](#)

- Mertes, S., Schroder, F., and Wiedensohler, A.: The particle-detection efficiency curve of the TSI-3010 CPC as a function of the temperature difference between saturator and condenser, *Aerosol Sci. Technol.*, 23, 257–261, 1995. 6
- 5 Tarvainen, V., Hakola, H., Hellén, H., Bäck, J., Hari, P., and Kulmala, M.: Temperature and light dependence of the VOC emissions of Scots pine, *Atmos. Chem. Phys. Discuss.*, 4, 6691–6718, 2004, [SRef-ID: 1680-7375/acpd/2004-4-6691](#). 7
- Voutilainen, A., Kolehmainen, V., and Kaipio, J. P.: Statistical inversion of aerosol size measurement data, *Inverse Probl. Eng.*, 9, 67–94, 2001. 6
- 10 Vuorinen, T., Nerg, A. M., and Holopainen, J. K.: Ozone exposure triggers the emission of herbivore-induced plant volatiles, but does not disturb tritrophic signalling, *Environ. Pollut.*, 131, 305–311, 2004a. 3
- Vuorinen, T., Nerg, A. M., Ibrahim, M. A., Reddy, G. V. P., and Holopainen, J. K.: Emission of *Plutella xylostella*-induced compounds from cabbages grown at elevated CO₂ and orientation behavior of the natural enemies, *Plant Physiol.*, 135, 1984–1992, 2004b. 3, 4, 5, 6
- 15 Winklmayr, W., Reischl, G. P., Lindner, A. O., and Berner, A.: A new electromobility spectrometer for the measurement of aerosol size distributions in the size range from 1 to 1000 nm, *J. Aerosol Sci.*, 22, 289–296, 1991. 6

**Particle formation by
ozonolysis of plant
volatiles**J. Joutsensaari et al.

[Title Page](#)[Abstract](#)[Introduction](#)[Conclusions](#)[References](#)[Tables](#)[Figures](#)[◀](#)[▶](#)[◀](#)[▶](#)[Back](#)[Close](#)[Full Screen / Esc](#)[Print Version](#)[Interactive Discussion](#)

Particle formation by ozonolysis of plant volatiles

J. Joutsensaari et al.

Table 1. VOC (terpenes and two green leaf volatiles) emissions (\pm SD, ng g^{-1} d.w. h^{-1}) of cabbage cultivars Lennox and Rinda. VOCs were analyzed from intact (control) and MeJA-treated (sprayed with 10 mM MeJA 4 days prior to the experiments) cabbage plants ($n=5$ per cv.). Asterisks denote statistically significant ($P<0.05$, Mann-Whitney U-test) difference between treatment means among the cultivar. Superscripts MT, HT, ST, and GLV denote a class of VOC: monoterpene, homoterpene, sesquiterpene, and green leaf volatile, respectively. DMNT=(*E*)-4,8-dimethyl-1,3,7-nonatriene.

	cv. Lennox		cv. Rinda	
	Control	MeJA	Control	MeJA
α -thujene ^{MT}	1.4 \pm 3.2	36.7 \pm 9.6*	8.2 \pm 5.3	37.6 \pm 12.7*
α -pinene ^{MT}	0	20.7 \pm 3.7*	1.0 \pm 2.2	20.9 \pm 9.3*
sabinene ^{MT}	11.3 \pm 11.6	115.1 \pm 25.4*	5.2 \pm 11.5	115.9 \pm 53.4*
β -pinene ^{MT} + myrcene ^{MT}	0	47.2 \pm 10.8*	11.54 \pm 1.0	47.6 \pm 21.6*
limonene ^{MT}	30.1 \pm 14.2	377.8 \pm 96.4*	55.64 \pm 70.79	133.2 \pm 85.2
1,8-cineole ^{MT}	18.5 \pm 6.0	61.9 \pm 11.0*	39.27 \pm 47.56	81.7 \pm 44.2
DMNT ^{HT}	0	76.5 \pm 23.7*	0	41.0 \pm 10.4*
(<i>E,E</i>)- α -farnesene ST	0	26.1 \pm 19.8	3.94 \pm 8.80	43.2 \pm 22.7*
Total terpene emission	61.3\pm8.1	761.9\pm143.8*	124.8\pm115.5	521.1\pm235.4
(<i>Z</i>)-3-hexen-1-ol+(<i>E</i>)-2-hexenal ^{GLV}	0	39.5 \pm 53.7	87.81 \pm 138.90	0
(<i>Z</i>)-3-hexenyl acetate ^{GLV}	0	146.2 \pm 169.2*	160.2 \pm 189.6	35.2 \pm 23.9
Total VOC emission	61.3\pm8.1	947.5\pm362.5*	372.8\pm319.3	556.3\pm224.4

Title Page

Abstract

Introduction

Conclusions

References

Tables

Figures

◀

▶

◀

▶

Back

Close

Full Screen / Esc

Print Version

Interactive Discussion

EGU

Particle formation by ozonolysis of plant volatiles

J. Joutsensaari et al.

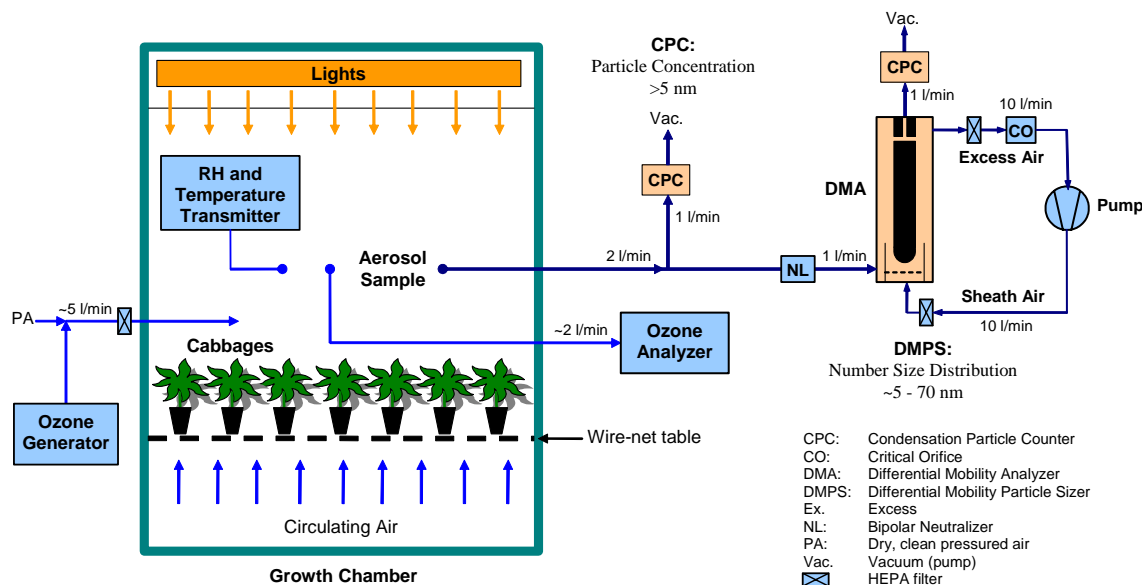

Fig. 1. Experimental setup used in aerosol formation experiments during ozone pulses over treated cabbage plants.

Title Page

Abstract

Introduction

Conclusions

References

Tables

Figures

◀

▶

◀

▶

Back

Close

Full Screen / Esc

Print Version

Interactive Discussion

EGU

Particle formation by
ozonolysis of plant
volatiles

J. Joutsensaari et al.

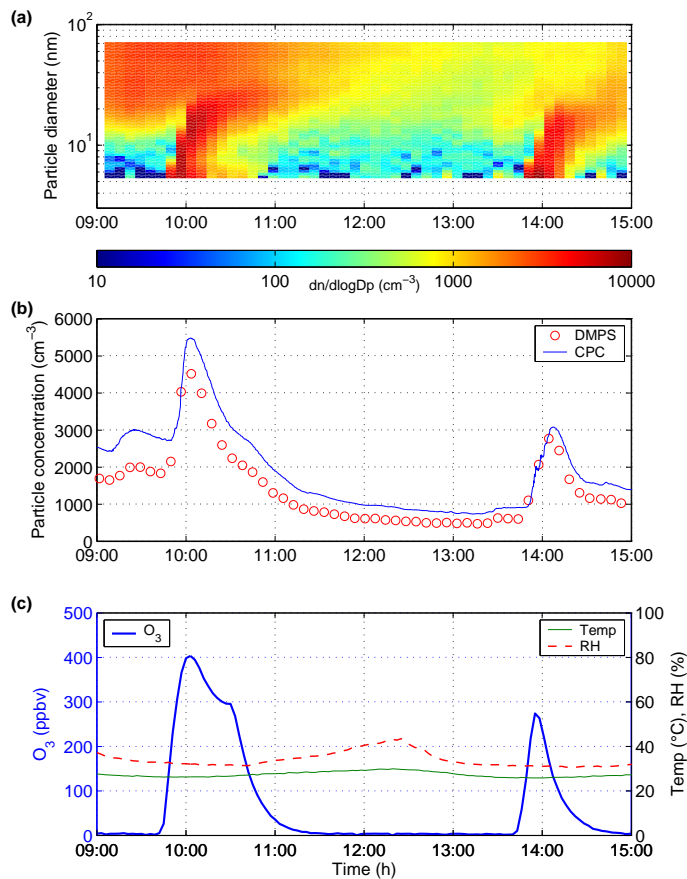

Fig. 2. Fine particle nucleation over MeJA-treated cabbage plants (cvs. Lennox and Rinda): **(a)** a contour plot of aerosol particle number size distributions (measured with the DMPS), **(b)** aerosol particle number concentrations (from DMPS and CPC results), and **(c)** ozone (O_3) concentration, relative humidity (RH) and temperature (Temp) during two consecutive ozonolysis experiments.

[Title Page](#)[Abstract](#)[Introduction](#)[Conclusions](#)[References](#)[Tables](#)[Figures](#)[◀](#)[▶](#)[◀](#)[▶](#)[Back](#)[Close](#)[Full Screen / Esc](#)[Print Version](#)[Interactive Discussion](#)

EGU