



HAL
open science

Multicarrier CDMA: A very promising multiple access scheme for future wideband wireless networks

Jean-François H elard, Jean-Yves Baudais, Jean-Michel Auffray

► **To cite this version:**

Jean-Fran ois H elard, Jean-Yves Baudais, Jean-Michel Auffray. Multicarrier CDMA: A very promising multiple access scheme for future wideband wireless networks. European Workshop on Integrated Radio Communication Systems, May 2002, Angers, France. <hal-00283645>

HAL Id: hal-00283645

<https://hal.science/hal-00283645v1>

Submitted on 18 Sep 2014

HAL is a multi-disciplinary open access archive for the deposit and dissemination of scientific research documents, whether they are published or not. The documents may come from teaching and research institutions in France or abroad, or from public or private research centers.

L'archive ouverte pluridisciplinaire **HAL**, est destin e au d p t et   la diffusion de documents scientifiques de niveau recherche, publi s ou non,  manant des  tablissements d'enseignement et de recherche fran ais ou  trangers, des laboratoires publics ou priv s.



HAL Authorization

MULTICARRIER CDMA: A VERY PROMISING MULTIPLE ACCESS SCHEME FOR FUTURE WIDEBAND WIRELESS NETWORKS

(Invited paper)

Jean-François HELARD, Jean-Yves BAUDAIS, Jean-Michel AUFFRAY
Institut d'Electronique et de Télécommunications de Rennes (IETR – UMR 6164)
INSA – 20 Avenue des Buttes de Coësmes, 35043 Rennes Cedex
jean-francois.helard@insa-rennes.fr

Abstract

In this paper, multicarrier techniques are studied in the context of the future wideband wireless networks. After a brief presentation of the third generation mobile networks, MC-CDMA systems are considered for the downlink of the future high rate cellular networks. The performance of different mono-user and multi-user detection techniques are compared with the help of Monte Carlo simulations over a frequency selective Rayleigh channel. Thus, the efficiency of MC-CDMA as a very promising multiple access and robust modulation scheme is successfully demonstrated for the downlink of the future wideband mobile networks. Finally, the first results concerning the performance of Multicarrier CDMA technique combined with space-time block coding in order to build a Multiple Input Multiple Output/MC-CDMA system are presented over a Rayleigh channel.

I Introduction

The European third generation (3G) terrestrial mobile system under deployment aims at offering a large variety of circuit and packet services and greater capacity compared to second-generation (2G) systems, GSM (Global System for Mobile Communications) and its annual releases leading to the introduction of GPRS (General Packet Radio Service) and EDGE (Enhanced Data rates for GSM Evolution). The evolution from 2G to 3G corresponds to adopting a new air interface but most of all to a change of focus from voice to multimedia. Meanwhile, there is already an urgent necessity to start thinking now about 4th Generation (4G) [1] in order to offer very high data rates over broadband radio channels for future multimedia services (internet, video transmission, data transfer...).

These last ten years, we have observed the success of spread spectrum communications in mobile cellular networks, whose first commercial widespread deployment came with the CDMA based mobile radio standard IS-95 in the USA. Nowadays, with the use of CDMA for third generation mobile radio systems as IMT2000 (International Mobile Telephony) and its european component UMTS (Universal Mobile Telecommunication System) in Europe, the success of this technique is unquestionable. So, to enable symmetric and asymmetric data services in a spectrum efficient way, the UMTS Terrestrial Radio Access (UTRA) supports respectively FDD (Frequency Division Duplex) and TDD (Time Division Duplex), which are both based on the CDMA technology. Wideband CDMA, the leading candidate for FDD mode leans on direct sequence spread spectrum with a chip rate of 3.84 Mchip/s and a transmitted signal bandwidth of about 5 MHz. It supports circuit and packet data access at nominal peak data rate equal to 384 Kbit/s for macro cellular environment with a vehicular mobility and up to 2 Mbit/s for indoor environments with a pedestrian mobility [2] as shown in Figure 1, which gives the mobility versus the data rates for current and future wireless access systems.

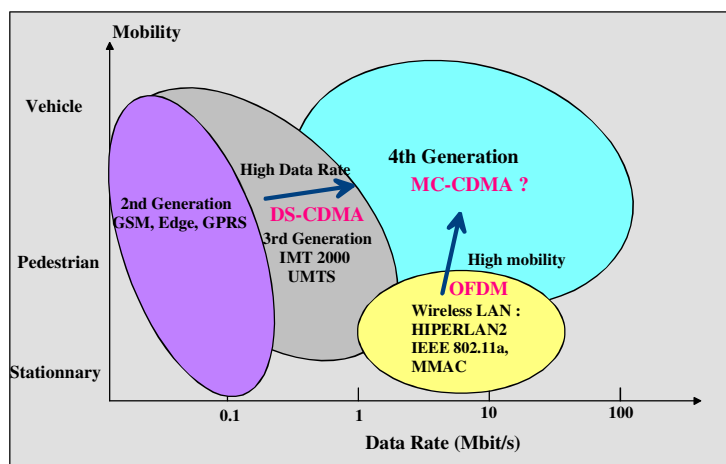

Figure 1 – Mobility versus data rate for wireless access systems

Meanwhile, the multi-carrier technique, well known under the acronym OFDM, which stands for Orthogonal Frequency Division Multiplexing, has been receiving widespread interest for wireless broadband multimedia applications over the last decade. The main advantages of this technique are widely known: robustness and high spectrum efficiency in frequency-selective and time-variant fading channels, capability of portable and mobile reception and flexibility. Introduced into European digital broadcasting systems like Digital Audio Broadcasting (DAB) and Digital Video Broadcasting-Terrestrial (DVB-T) [3], OFDM was selected for next generation Wireless Local Area Networks (WLAN) like ETSI-HIPERLAN/2 [4], American IEEE-802.11a and Japanese MMAC as illustrated in Figure 1. These standards will offer high bit rates from 6 to 54 Mbit/s on the physical layer for short range communications typically in offices and home environment with a 20 MHz channel spacing in the 5 GHz.

Today, one of the most promising candidate for the 4th Generation air interface is Multi-Carrier Code Division Multiple Access (MC-CDMA) [5][6], as mentioned in Figure 1. Based on the combination of multi-carrier modulation and spread spectrum, MC-CDMA benefits from the main advantages of both schemes: high spectral efficiency, high flexibility, multiple access capabilities, narrow-band interference rejection, simple one-tap equalisation, ... During the last years, deep system analysis and comparison of MC-CDMA with DS-SS-SSMA have been performed demonstrating the superiority of MC-CDMA [7][8]. With respect to UMTS and IMT requirements based on a 5 MHz bandwidth channel for FDD mode, it is for example demonstrated in [9] that with MC-CDMA technology, a net bit rate of up to 4 Mbit/s with a 1/2 rate channel code and even 6 Mbit/s with a 3/4 rate code could be assigned to a single user for indoor but also macro cellular environments with a vehicular mobility. Those figures have to be compared to the previous throughputs offered by UMTS and reminded at the beginning of this introduction. However, further researchs on integration and optimization of processing techniques as coding and modulation, multi-user detection techniques, channel estimation, synchronisation and networks issues are required.

The purpose of this paper is to give a general framework for MC-CDMA, to discuss the detection techniques and to study its performance for the downlink of high rate cellular networks. In section II, we give a general presentation of MC-CDMA systems. After a functional description of the transmitter and the receiver, section III discusses the detection problem with a presentation of different mono-user detection techniques. Section IV deals with multi-user detection techniques. Interference cancellation techniques and a new Global Minimum Mean Square Error (GMMSE) detection technique are compared. It is shown that this new linear detection scheme offers very good performance mainly for non-full load systems. Furthermore, different results are given for a synchronous MC-CDMA system with various combinations of GMMSE and interference cancellation techniques, in order to look for the scheme that will offer the best trade-off between performance and complexity. Then, in section V, the first results concerning the performance of Multicarrier CDMA modulation combined with space-time block coding in order to build a Multiple Input Multiple Output / MC-CDMA system are presented over a Rayleigh channel. Finally, section VI summarises the results and draws together the conclusions.

II Multi-carrier spread spectrum concept

The MC-CDMA concept, also known as OFDM/CDMA, is based on a serial concatenation of Direct Sequence spreading with Multi-Carrier Modulation. The MC-CDMA transmitter spreads the original data stream over different subcarriers in the frequency domain using a given spreading code. The effect of spreading is that different users can have access to the same carriers in a CDMA manner. The separation of the user's signals is then performed in the code domain. The advantage of MC-CDMA in comparison with DS-SS-SSMA is that the spreading can be adapted to the frequency selective behaviour of the channel. Simple methods for signal detection in the frequency domain as one-tap equaliser per carrier can be used. Figure 2 shows the MC-CDMA transmitter of the j^{th} user and the power spectrum of the transmitted signal.

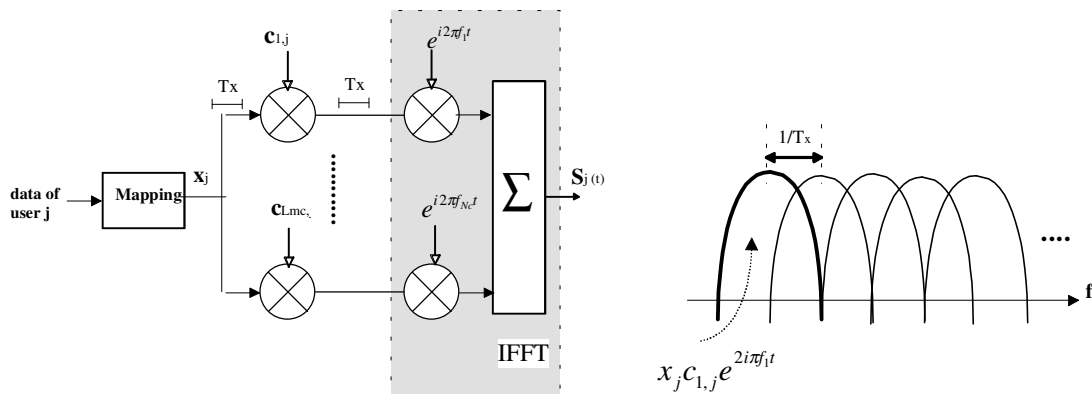

Figure 2 — MC-CDMA transmitter scheme and power spectrum of the transmitted signal.

The data symbol $x_j(t)$ of the user j is transmitted in parallel over N_c subcarriers, each multiplied by one chip $c_{k,j}$ of the spreading code $C_j(t) = [c_{1,j} c_{2,j} \dots c_{L_{mc},j}]$ assigned to user j . In this figure, the length L_{mc} of the spreading code is equal to the number N_c of subcarriers but this is not mandatory. As a consequence, the MC-CDMA systems offer an additional degree of freedom, and actually the number N_c of subcarriers is chosen to guarantee frequency non-selective fading over each subcarrier. The expression of the transmitted signal $S_j(t)$ of user j during the time interval $[0, T_x]$ is:

$$S_j(t) = \text{Re} \left\{ \sum_{k=1}^{N_c} x_j P(t) c_{k,j} e^{i2\pi f_k t} \right\}, \quad 0 \leq t < T_x \quad \text{with } f_k = f_0 + \frac{k}{T_x}$$

where T_x is the data symbol duration which is in this case equal to the OFDM symbol duration, x_j the data symbol transmitted during the signalling interval $[0, T_x]$, $P(t)$ the pulse shaping waveform which is generally rectangular and f_0 is the carrier frequency.

Practically, the MultiCarrier modulation and demodulation is easily carried out in the digital domain by performing IFFT and FFT operations. Furthermore the insertion between adjacent MultiCarrier (MC) symbols of a guard interval Δ , longer than the delay spread of the impulse response of the channel, guarantees the absence of Inter Symbol Interference (ISI) during the "useful" part of the symbol. In the receiver, after direct FFT and possibly de-interleaving, the received sequence is "equalised" in the frequency domain. Therefore, the MC-CDMA receiver can always employ all the received signal energy spread in the frequency domain. Undoubtedly, this is the main advantage of the MC-CDMA scheme compared to a DS-CDMA Rake receiver that has difficulties in making full use of the received signal energy scattered in the time domain. For a synchronous system as the downlink mobile radio communication channel, the application of orthogonal codes such as Walsh-Hadamard codes guarantees the absence of Multiple Access Interference (MAI) in a gaussian channel. However, in non-ideal channels with frequency selective fading due to multipath propagation, the orthogonality between the signals of the different users is lost and MAI occurs. To combat the channel fading and thus the MAI, a multitude of detection techniques was proposed. They can be classified as either single-user detection (SD) or multi-user detection (MD), as we will see in the following sections.

III Performance analysis of MC-CDMA systems with single user detection techniques

III.1 MC-CDMA transmitter and receiver

The block diagram of the considered MC-CDMA transmitter and receiver is depicted in Figure 3 for the downlink. Each data symbol x_j^n assigned to user j , $j = 1, \dots, N_u$ and transmitted during the symbol interval n is multiplied with its user specific Walsh-Hadamard spreading code $C_j(t) = [c_{1,j} \ c_{2,j} \ \dots \ c_{L_{mc},j}]^T$ of length L_{mc} , where $[\cdot]^T$ denotes matrix transposition. L_{mc} corresponds to the bandwidth expansion factor and is equal to the maximum number of simultaneous active users. The j^{th} column vector of the $L_c \times L_c$ matrix C corresponds to the spreading code C_j of the user j .

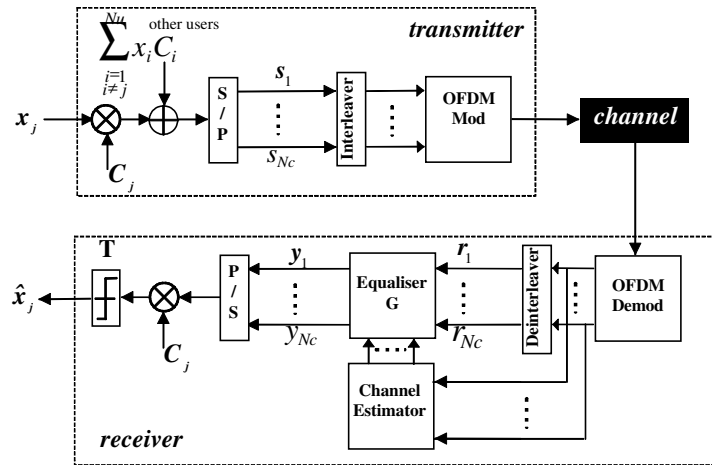

Figure 3 — Studied MC-CDMA transmitter and receiver.

The vector of the data symbols transmitted during the n^{th} Orthogonal Frequency Division Multiplexing (OFDM) symbol by all the users can be written $\mathbf{X}^n = [x_1^n, x_2^n, \dots, x_j^n, \dots, x_{L_{mc}}^n]^T$, with $x_j^n = 0$ when user j is inactive. Since we consider the synchronous downlink of an MC-CDMA system, the different data modulated spreading codes of the N_u users can be added before Serial-to-Parallel (S/P) conversion. Furthermore, the N_u user signals are supposed to be transmitted with the same power. The number N_c of subcarriers which are QPSK modulated is chosen equal to the spreading code length L_{mc} . For this study, frequency non-selective Rayleigh fading per subcarrier and time invariance during one OFDM symbol are assumed. The absence of Intersymbol Interference is also guaranteed by the use of a guard interval longer than the delay spread of the impulse response of the channel. Based on these assumptions and considering time and frequency interleaving, the complex channel fading coefficients are independent for each subcarrier and can be estimated for the subcarrier k by $h_k = \rho_k e^{i\theta_k}$. The signal received after the inverse OFDM operation (serial to parallel conversion and direct FFT) and de-interleaving can be expressed as:

$$\mathbf{R} = [r_1, r_2, \dots, r_{N_c}]^T = \mathbf{H}\mathbf{C}\mathbf{X} + \mathbf{N}$$

where the $N_c \times N_c$ diagonal matrix $\mathbf{H} = \text{diag}\{h_1, \dots, h_{N_c}\}$ describes the complex channel frequency response and $\mathbf{N} = [n_1, n_2, \dots, n_{N_c}]^T$ is the Additive White Gaussian Noise (AWGN) vector with n_k representing the noise term at the subcarrier k with variance given by $\sigma_N^2 = E\{|n_k|^2\}$, $k = 1, \dots, N_c$.

After equalisation the received signal can be written as:

$$\mathbf{Y} = [y_1, y_2, \dots, y_{N_c}]^T = \mathbf{G}\mathbf{R} = \mathbf{G}\mathbf{H}\mathbf{C}\mathbf{X} + \mathbf{G}\mathbf{N}$$

In case of single user detection, the $N_c \times N_c$ matrix \mathbf{G} , which represents the complex equalisation coefficients is diagonal with $\mathbf{G} = \text{diag}\{g_1, \dots, g_{N_c}\}$. The different coefficients g_k can be derived from the channel estimation which is based on known transmitted pilot symbols inserted between the data carriers. Finally, after despreading and threshold detection, we obtain the detected data symbol x_j , which corresponds to the sign of the scalar product of the received vector \mathbf{Y} and the specific spreading code \mathbf{C}_j as:

$$\hat{x}_j = \text{sign}\langle \mathbf{Y}, \mathbf{C}_j \rangle = \text{sign} \left\{ \underbrace{\sum_{k=1}^{N_c} c_{k,j}^2 g_k h_k x_j}_{\lambda} + \underbrace{\sum_{i=1}^{N_u} \sum_{k=1}^{N_c} c_{k,i} c_{k,j} g_k h_k x_i}_{\gamma} + \underbrace{\sum_{k=1}^{N_c} c_{k,j} g_k n_k}_{\eta} \right\}$$

where \bullet represents the useful signal part, \bullet the MAI and \bullet the noise term.

III.2 Single user detection techniques: description and performance

Single-user detection is performed by one tap equalisation to compensate for the phase and amplitude distortions caused by the mobile radio channel. The one tap equaliser is simply one complex-valued multiplication per subcarrier. Various basic single user detection techniques can be implemented:

Maximum Ratio Combining technique (MRC): In the single user case, MRC is the optimum diversity combining technique. The corresponding equalisation coefficients are: $g_k = h_k^*$ where $*$ stands for complex conjugation. However, in a multi-user scenario, the multiplication by the conjugate complex channel coefficients results in enhanced MAI.

Equal Gain Combining technique (EGC): With EGC, only the phase shift is corrected. So, in fading channels the orthogonality of the Walsh-Hadamard spreading codes gets lost, resulting in MAI. The equalisation coefficients are: $g_k = h_k^* / |h_k|$

Orthogonality Restoring Combining technique (ORC): This technique, also called Zero Forcing (ZF), inverts the channel transfer function and thus restores the orthogonality between the users by applying $g_k = 1/h_k$. As the MAI is completely eliminated, performance does not depend on the number of active users. The drawback of ORC is that for small amplitude of h_k , the noise level is enhanced.

Minimum Mean Square Error technique (MMSE): Among all these single-user detection techniques, MMSE equalisation offers the best results. It minimizes the mean square value of the error ϵ_k between the signal s_k transmitted on subcarrier k and the assigned output y_k of the equaliser. The equalisation coefficients based on this MMSE criterion applied independently per

carrier are equal to: $g_k = \frac{h_k^*}{|h_k|^2 + \frac{1}{\gamma_c}} = \frac{h_k^*}{|h_k|^2 + \frac{N_c}{N_u} \frac{1}{\gamma_x}}$

where γ_c is the subcarrier signal to noise ratio and γ_x is the signal to noise ratio of the received data x_j .

As already reported in the previous section, the matrix \mathbf{G} is diagonal for all these basic single user detection techniques which means that the received sequence is equalised by using a bank of N_c adaptive one tap equalisers which results in a low complexity equaliser. The simulation results with MRC, EGC, ORC and MMSE detections are presented in Figure 4 for a Rayleigh channel with one transmit antenna ($N_t=1$) and one receive antenna ($N_r=1$), in order to compare those results to the performance of multiple antennas systems in section V. The number N_u of active users is equal to the spreading code length L_{mc} (full user capacity) which is also equal to the number $N_c=64$ of subcarriers. For this study, the synchronisation and the channel estimation are supposed to be perfect.

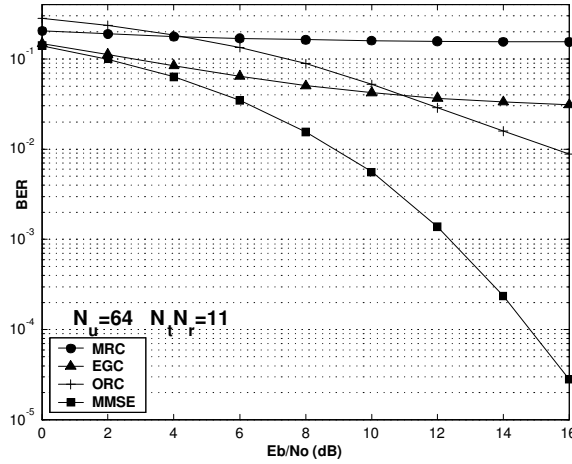

Figure 4 — Performance of single user detection techniques;
full load system: $N_u = L_{mc} = N_c = 64$.

The MMSE outperforms the other single user detection techniques avoiding an excessive noise amplification for low signal to noise ratios while restoring the orthogonality among users for large signal to noise ratios. The potential of MMSE already pointed out in many references [5][6] is there confirmed. However, this MMSE equalisation per carrier method is not optimal, since it does not take into account the despreading process and thus does not minimise the mean square error at the input of the threshold decoder. In order to obtain better performance, a new method based on a global implementation of the MMSE criterion is presented in the following section.

IV Multi-user detection

With the aim to improve the performance of the receiver still further, Multi-user Detection (MD) can be carried out, where the a priori knowledge about the spreading codes of the interfering users is exploited in the detection process. Based on the Maximum Likelihood criterion, the ML detector is the optimum detector. It applies Joint Detection (JD) with Maximum Likelihood Sequence Estimation (MLSE) or Maximum Likelihood Symbol-by-Symbol Estimation (MLSSE). Since the complexity of MLSE and MLSSE receivers grows exponentially with the number of users, their use is limited in practice to applications with a small number of users. Therefore, in order to handle a large number of users, receivers can implement sub-optimal non-linear interference cancellation (IC) techniques with lower complexity. The principle of IC is to detect the information of the interfering users and to reconstruct the interfering contribution in order to subtract it from the received signal. IC can be performed parallel for all interfering users with Parallel Interference Cancellation (PIC) detectors, or successively with Successive Interference Cancellation (SIC) detectors where only the strongest interferer remaining after the previous IC stage is cancelled. An other interesting solution is the linear Global Minimum Mean square Error (GMMSE) detection technique which can be combined to interference cancellation schemes as we will see in this section.

Successive Interference Cancellation

The SIC detector first detects the most powerful interfering user and then cancels its contribution from the received signal. The second strongest interferer is then cancelled and so on. The processing may be repeated for a few or for all users. A complete detector would consider all users, but commonly only the interferers stronger than the useful one are suppressed. SIC detector is generally used when the power of some users are higher than the power of the useful user. Since processing one supplementary stage leads to an additive time delay, a trade-off between the number of stages and the total acceptable delay has to be found. The process is carried out iteratively until the remained interferers are considered insignificant. The resulting signal is finally despread. The data detection may be hard or soft.

Parallel Interference Cancellation

The Parallel Interference Cancellation (PIC) structure is based on an estimation of the total interference due to the simultaneous other users in order to remove it from the received signal. The contribution of all interfering users is cancelled in parallel reducing the time delay of a SIC detector. The expression of this iterative system for the m^{th} stage and the j^{th} user is given by the following:

$$\hat{x}_j^{[m]} = \mathbf{C}_j^{*T} \mathbf{G}^{[m]} \left(\mathbf{R} - \mathbf{H} \sum_{i=1, i \neq j}^N \hat{x}_i^{[m-1]} \mathbf{C}_i \right) \quad m = 1, \dots, M_{it}$$

with the expression of the initial stage given by:

$$\hat{x}_j^{[0]} = \mathbf{C}_j^{*T} \mathbf{G}^{[0]} \mathbf{R} \quad j=1, \dots, N_u$$

The received signal is first equalised by a SU technique, then it is despread by each code. An Inverse Fast Hadamard Transform (IFHT) can be implemented since the system is synchronous. As for SIC detector, data detection may be either hard or soft. After detection, the data is spread again, tapped by the estimated channel coefficients \hat{H} and then subtracted from the received signal. Finally, the resulting signal with lower MAI term is then equalised, despread and detected. We can note that the second equaliser structure ($\mathbf{G}^{[m]}$) may be different from the first one ($\mathbf{G}^{[m-1]}$).

A new Global Minimum Mean Square Error (GMMSE) detection technique

The aim of this new method, which has been patented [11] and named as the Global MMSE algorithm, is to minimise the mean square error between the transmitted symbol x_j and the estimated symbol \hat{x}_j [10]. Let $\mathbf{W}_j^T = [w_j^0, w_j^1, \dots, w_j^{N_c}]$ be the optimal weighting vector. The estimated symbol of the j^{th} user is: $\hat{x}_j = \mathbf{W}_j^T \mathbf{R} = \mathbf{C}_j^T \mathbf{G} \mathbf{R}$

According to Wiener filtering, the optimal weighting vector is: $\mathbf{W}_j = \mathbf{\Gamma}_{R,R}^{-1} \mathbf{\Gamma}_{R,x_j}$ where $\mathbf{\Gamma}_{R,R}$ is the autocorrelation matrix of the received vector \mathbf{R} and $\mathbf{\Gamma}_{R,x_j}$ is the cross-correlation vector between the desired symbol x_j and the received signal vector \mathbf{R} . The subcarrier noises have the same variance and are independent. Thus, $E\{NN^{*T}\} = \sigma_N^2 \mathbf{I}$ where \mathbf{I} is the identity matrix. In the downlink, since the user signals have the same power ($E\{x_j^2\} = E_s$) and are independent, we can write $E\{\mathbf{X}\mathbf{X}^{*T}\} = E_s \mathbf{A}$, where $\mathbf{A} = \{a_{ij}\}$ is a diagonal matrix with the term $a_{jj} = 1$ if the user j is active and $a_{jj} = 0$ if the user j is inactive. Then, the equalisation coefficient matrix is:

$$\mathbf{G} = \mathbf{H}^* \left(\mathbf{H}\mathbf{C}\mathbf{A}\mathbf{C}^T \mathbf{H}^* + \frac{\sigma_N^2}{E_s} \mathbf{I} \right)^{-1}$$

In the full load case ($N_u = L_{mc}$) and only in that case, the quantity $\mathbf{C}\mathbf{A}\mathbf{C}^T$ is equal to the identity matrix and the equalisation coefficients matrix \mathbf{G} is a diagonal matrix with the k^{th} subcarrier equalisation coefficient equal to the former equation given for MMSE single user detection. On the other hand, when the capacity is not full ($N_u < L_{mc}$), the equalisation coefficient matrix \mathbf{G} is no more diagonal. In that case, the Global MMSE (GMMSE) algorithm outperforms the MMSE per carrier algorithm, since it minimizes the decision error taking into account the de-spreading process instead of minimizing the error independently on each subcarrier.

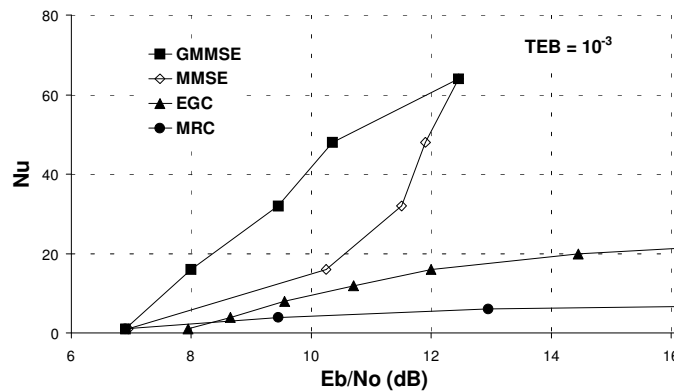

Figure 5 — Maximum number N_u of active users against E_b/N_0 for $\text{BER} = 10^{-3}$ and $L_{mc} = N_c = 64$ with equal mean power signals.

Figure 5 shows the performance of various detection systems with $L_{mc} = N_c = 64$, taking into account the number N_u of active users against the required E_b/N_0 to achieve a $\text{BER} = 10^{-3}$, with equal mean power signals. In any case, MRC and EGC perform poorly. The performance of the MMSE system, with the equalisation coefficients optimised independently on each subcarrier can be compared to the performance of the GMMSE system. For full load systems ($N_u = L_{mc} = 64$), the two MMSE approaches offers the same results, while for non-full load systems the GMMSE achieves a gain of more than 2 dB with $N_u = 32$ or 16, which corresponds to a system load respectively equal to 50 % and 25 %.

In order to improve the performance still further, it is possible to combine linear GMMSE and non linear Interference Cancellation techniques. In Figure 6, the performance of two stage parallel interference cancellation PIC-MMSE and PIC-GMMSE are compared to MMSE, GMMSE, SIC-MMSE and SIC-GMMSE with $L_{mc} = N_c = 16$. The number N_u of active

users against the required E_b/N_0 to achieve a BER = 10^{-3} is given with equal mean power signals. In any case, the two stage PIC-GMMSE scheme offers the best results. Furthermore, this figure shows that for N_u inferior to the maximum number $L_{mc} = 16$ active users, the linear GMMSE offers almost the same performance. This clearly indicates a possible trade-off between performance and complexity in favor of the less complex linear GMMSE technique.

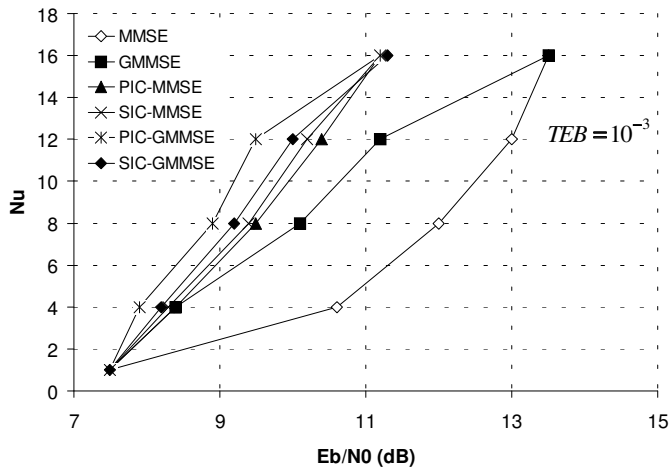

Figure 6 — Maximum number N_u of active users against E_b/N_0 for BER = 10^{-3} and $L_{mc} = N_c = 16$ with equal mean power signals.

V Combining space-time block coding with MC-CDMA

For future wideband wireless networks, space diversity schemes relying on multiple antennas at the receiver and the transmitter in order to build a Multiple Input Multiple Output system are very attractive to combat fading and improve the transmission performance [12]. Recently, space-time coding, such as Space-Time Block Coding (STBC), relying on multiple-antenna transmissions and appropriate signal processing in the receiver was proposed [13]. It provides diversity and interesting coding gains compared to uncoded single-antenna transmissions. So, in order to take advantage of the space diversity, the combination of MC-CDMA systems with space-time coding as STBC has been studied in the case of two transmit antennas, $N_t = 2$, and two receive antennas, $N_r = 2$. The principle of the selected STBC proposed by Alamouti in [13] is shown on Table 1.

	t	t + T _x
Antenna 1	x_j^0	$-x_j^{1*}$
Antenna 2	x_j^1	x_j^{0*}

Table 1— Principle of the encoding and transmission diversity scheme

The two successive data symbols x_j^0 and x_j^1 presented at the input of the space-time encoder for user j are sent respectively to antennas 1 and 2 during the first symbol period, while during the next symbol period, $-x_j^{1*}$ and x_j^{0*} are respectively sent to antennas 1 and 2, where $[]^*$ denotes the complex conjugate operation. As the space-time coding is carried out on two adjacent OFDM symbols, the receiver has to deal with two successive symbols as a whole. For each receive antenna r , the two signals $r_r(t)$ and $r_r(t+T_x)$ are combined after equalisation, as explained in detail in [14]. The resulting signals from the two antennas are then added in order to detect the two symbols x_j^0 and x_j^1 . The simulation results are presented on Figure 7 for various single user detection techniques in the full load case, *i.e.*, with $N_u = L_{mc} = N_c$. As expected, MMSE outperforms the other single user detection techniques. Furthermore, compared to the previous results shown on Figure 4, the performance of MC-CDMA is highly improved when combined with STBC, in order to exploit the transmit diversity. Besides, it can be shown that the transmit diversity gain is all the more significant that the number of active users N_u is high.

VI Conclusion

In this paper, we have described the MC-CDMA system well adapted to the downlink of wireless high rate system cellular networks. Existing single user and multi-user detection techniques have been presented. Performance comparisons show that the GMMSE scheme offers very good results, mainly for non-full load systems. This is confirmed by the results published in [9], which demonstrate how efficient the use of the GMMSE detector is over BU, HT and Vehicular channels, especially when associated with a powerful Turbo Code.

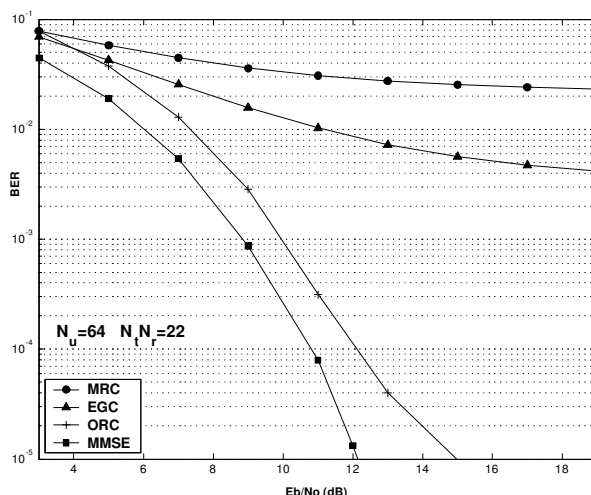

Figure 7 — Performance of MIMO/MC-CDMA systems with single user detection techniques;
Two transmit antennas ($N_t = 2$), two receive antennas ($N_r = 2$); full load system: $N_u = L_{mc} = N_c = 64$.

Thus, it is shown that MC-CDMA is a very promising multiple access scheme especially for the downlink of future mobile radio systems. Finally, the performance of MC-CDMA is highly improved when combined with STBC in order to take benefit of the transmit diversity. These promising results warrant why those techniques are now studied within the framework of a new european IST project named MATRICE which stands for "Multicarrier CDMA Transmission Techniques for Integrated Broadband Cellular Systems".

Acknowledgements: The authors would like to thank the European Commission which supports a part of this study.

References:

- [1] PEREIRA (J. M.), A personal perspective of fourth generation. *Teletronikk, Wireless future*, **97**, N°1 - 2001, pp. 20-30, (1 - 2001).
- [2] CHARLES (J-P), 3rd generation mobile systems UMTS/IMT2000. *Annales des Télécommunications, UMTS technology advances*, vol. 56, N° 5/6, pp. 229-235, (Mai/Juin 2001).
- [3] ETSI ETS 300 744, Digital video broadcasting (DVB): framing structure, channel coding and modulation for digital terrestrial television (DVB-T), (March 1997).
- [4] ETSI. Project Broadband Radio Access Networks (BRAN); HIPERLAN Type 2, Technical specification; Physical layer, (October 1999).
- [5] YEE (N.), LINNARTZ (J.P.), FETTWEIS (G.). Multicarrier CDMA in indoor wireless radio networks. *Proceedings of IEEE PIMRC'93*, pp 109-113, Yokohama, Japan, (1993).
- [6] HARA (S.), PRASAD (R.). Overview of multicarrier CDMA. *IEEE Communications Magazine*, pp 126-133, (December 1997).
- [7] KAISER (S). OFDM-CDMA versus CDMA: performance evaluation for fading channels. *IEEE International Conference on Communications*, pp 1722-1725 (June 1995).
- [8] OH (J-Y.), LIM (M-S.). The bandwidth efficiency increasing method of multicarrier CDMA and its performance evaluation in comparison with DS-SS-CDMA with Rake receivers. *Proceedings of IEEE Vehicular Technology Conference*, pp. 561-565 (1999).
- [9] HELARD (M.), LE GOUABLE (R.), HELARD (J-F.), BAUDAIS (J-Y.). Multicarrier techniques for future wideband wireless networks. *Annales des Télécommunications, UMTS technology advances*, vol. 56, N° 5/6, pp. 260-274, (Mai/Juin 2001)
- [10] BAUDAIS (J.-Y.), HELARD (J.-F.), CITERNE (J.). An improved linear MMSE detection technique for Multi-Carrier CDMA systems: comparison and combination with interference cancellation. *European Transactions on Telecommunications*, Special issue on Multi-Carrier Spread-Spectrum, vol. 11, N°6, pp.547-554, (December 2000).
- [11] BAUDAIS (J.-Y.), HELARD (J.-F.). Procédé d'égalisation dans des récepteurs utilisant une combinaison des techniques de modulations à porteuses multiples et à accès multiple par répartition de codes. French patent N° 99/11689 (September 1999) and N° 99/15919 (December 1999).
- [12] FOSCHINI (G.L.), GANS (M.J.). On limits of wireless communication in a fading environment when using multiple antennas. *Wireless Personal Communications*, vol. 6, pp. 331-335, (1998).
- [13] ALAMOUTI (S.M.). A simple transmit diversity technique for wireless communications. *IEEE Journal on Selected Areas in Communications*, vol.16, pp. 1451-1458, (Oct. 1998).
- [14] AUFRAY (J.-M.). HELARD (J.-F.). Performance of multicarrier CDMA technique combined with space-time block coding over rayleigh channel. *Submitted to IEEE International Symposium on Spread Spectrum Techniques and Applications 2002*.